



# İçindekiler Index Inhaltsverzeichnis



<b>Genel Bilgiler</b> <i>General Info.</i> Einführung	<b>Sembollerin Açıklaması</b>	<i>Key of Symbols</i>	Erklärung der Bezeichnungen	
	<b>Ürün Yelpazesi</b>	<i>Production Range</i>	Produktpalette	04
	<b>K Serisi Redüktörlerin Genel Özellikleri</b>	<i>General Specifications of K Series Gearboxes</i>	Allgemeine Eigenschaften Von K Serie Getrieben	06
	<b>Teknik Tanımlamalar</b>	<i>Technical Explanations</i>	Technische Erläuterungen	07
	<b>Teknik Özellikler</b>	<i>Technical Specifications</i>	Technische Informationen	07
	<b>Aksesuarlar</b>	<i>Accessories</i>	Zubehör	08
	<b>Tip Tanımlaması</b>	<i>Unit Designation</i>	Typenbezeichnungen	10
	<b>Örnek Tip Tanımlamaları</b>	<i>Sample Designations</i>	Typenbezeichnungsbeispiele	13
	<b>Redüktör Çıkış Özellikleri</b>	<i>Redüktör Output Specifications</i>	Eigenschaft der Ausgang	
	<b>Motor Büyüklüğüne Göre Geometrik Mümkün Çevrim Oranı Komb.</b>	<i>Geomet. Possible Combinations of Ratios According to Motor Size</i>	Geomet. Mögliche Kombi. von Übersetz. nach Motorbaugröße	16
	<b>Servis Faktörü</b>	<i>Service Factor</i>	Betriebsfaktor	18
	<b>Yük Sınıflandırması</b>	<i>Load Classification</i>	Belastungsart	19
	<b>Redüktör Dönüş Yönleri</b>	<i>Direction of Rotation</i>	Getriebedrehrichtungen	21
	<b>Radyal Yükler</b>	<i>Overhung Loads</i>	Querkräfte	22
	<b>Radyal Yüklerin Hesabı</b>	<i>Calculation Of Overhung Loads</i>	Berechnung der Querkräfte	23
	<b>Ekstruder Tiplerde Müsade Edilebilir Eksenel Yükler</b>	<i>Permissible Axial Loads for Extruder Types</i>	Zulässige Axialkräfte für Extruder Typ Getrieben	25
	<b>Eşdeğer Güç Hesabı</b>	<i>Equivalent Power Calculation</i>	Äquivalente Leistung	26
	<b>Eşdeğer Güç Hesabı Örneği</b>	<i>Equivalent Power Cal. Example</i>	Beispiel für Äquivalente Leistung	27
	<b>Redüktör Seçimi</b>	<i>Gearbox Selection</i>	Getriebeauswahl	28
	<b>Redüktör Seçim Formu</b>	<i>Gearbox Selection Form</i>	Formular für Getriebeauswahl	30
	<b>Yağlama</b>	<i>Lubrication</i>	Schmierung	34
	<b>Yağ Tipleri</b>	<i>Oil Types</i>	Schmierstoffe	35
	<b>Montaj Pozisyonları</b>	<i>Mounting Positions</i>	Bauformen	36
	<b>Yağ Tapaları</b>	<i>Oil plugs</i>	Ölverschlussschrauben	37
<b>Motorlar</b> <i>Motors</i> Motor	<b>Yağ Miktarları</b>	<i>Oil Quantities</i>	Ölmengen Tabellen	38
	<b>AC Motorlar</b>	<i>AC Motors</i>	Drehstrommotoren	40
	<b>a- Genel Özellikler</b>	<i>a- General Spec. of AC Motors</i>	a-Eigensch. des Drehstrommotors	40
	<b>b- Çalışma Türleri</b>	<i>b-Modes of Operation</i>	b-Betriebsarten	41
	<b>c- Koruma Sınıfı</b>	<i>c- Protection Class</i>	c- Schutzarten	42

K0601-0112



# İçindekiler

## Index

### Inhaltsverzeichnis



<b>Motorlar</b> <i>Motors</i> Motor	<b>d- İzolasyon Sınıfı</b>	<i>d- Insulation Class</i>	d- Isolationsklasse	42
	<b>e- Verim Sınıfları</b>	<i>e- Efficiency Classes</i>	e- Energieeffizienzklassen	42
	<b>f- AC Frekans İnvörtörler</b>	<i>f- AC Frequency Inverters</i>	f- AC Frequenz Umrichter	<b>43</b>
	<b>DC Motorlar</b>	<i>DC Motors</i>	DC Motoren	
	<b>a- Genel Özellikler</b>	<i>a- General Specif. of DC Motors</i>	a- Eigenschaften von DC Motoren	44
	<b>b- DC Motorların Çalışma İlkeleri</b>	<i>b- Operating principals of DC Motors</i>	b- Funktionsprinzip der DC Motoren	44
	<b>c- DC Motor Çeşitleri</b>	<i>c- Types of DC Motors</i>	c- Arten von DC Motoren	44
	<b>d- DC Motorlarda Hız Kontr.</b>	<i>d- Speed Control of DC motors</i>	d- Drehzahl Kontrolle DC Motoren	44
<b>Frenler</b> <i>Brakes</i> Bremsen	<b>Elektromanyetik Frenler</b>	<i>Electromagnetic Brakes</i>	Elektromagnetische Bremsen	45
	<b>Fren Çeşitleri</b>	<i>Brake Types</i>	Bremsenarten	46
	<b>Fren Bağlantı Şekli</b>	<i>Connection Types</i>	Schaltungsarten	47
	<b>Fren Seçimi</b>	<i>Brake Selection</i>	Bremswahl	47
	<b>Frenin Termik Kapasitesi</b>	<i>The Thermal Capacity of Brake</i>	Therm. Kapazität der Bremsen	48
<b>Güç Devir Tabl.</b> <i>Perform. Tables</i> Leistung-Drehzahl Tabellen.	<b>Motorlu Güç Devir Tabloları</b>	<i>Geared Motors Performance Tables</i>	Getriebeleistung und Drehzahl Übersicht	49
	<b>Motorsuz Güç Devir Tabloları</b>	<i>Gear Units Performance Tables</i>	Getriebe Leistung und Drehzahl-übersicht	325
<b>Ölçü Sayfaları</b> <i>Dimension Pages</i> Abmesungs Tabellen	<b>KR serileri</b>	<i>KR series</i>	KR serie	79
	<b>KN serileri</b>	<i>KN series</i>	KN serie	161
	<b>KV serileri</b>	<i>KV series</i>	KV serie	243
	<b>KT serileri</b>	<i>KT series</i>	KT serie	333
<b>Mil ve Kovan Ölçüleri</b> <i>Shaft and Hollow Shaft Dimensions</i> Wellen und Gehäusemaße	<b>K....0E Ekstruder Boğazlı Redüktörler</b>	<i>K....0E Extruder Type Gearboxes</i>	K....0E Extruder Getriebe von K Serie	414
	<b>K....0S Sıkma Bilezikli Redüktörler</b>	<i>K....0S Gearboxes with Shrink Disk Connector</i>	K....0S Serie Hohwelle mit Schrumpfscheibe	415
	<b>K serisi Kovan Ölçüleri</b>	<i>K series Hollow Shaft Dimensions</i>	Gehäuseabmessungen von K Serie Getriebe	416
	<b>Moment Kollu Redüktörler</b>	<i>Gearboxes with Torque Arm</i>	Drehmomentstütze Montagezeichnungen	416
	<b>K Serisi Redüktörler için Montaj Önerileri</b>	<i>Mounting Advices for Hollow Shaft Gearboxes</i>	Montagevorschläge Für D Serie Getriebe	417



# Genel Bilgiler

## General Information

### Einführung



#### Sembollerin Açıklaması

$c_t$ .....: Anahtarın devreye girme zamanı katsayısı

$f_s$ .....: Servis faktörü

$F_{ama}$ .....: Çıkış milinde müsaade edilen eksenel yükler [kN]

$F_{ame}$ .....: Giriş milinde müsaade edilen eksenel yükler [kN]

$F_{qam}$ .....: Çıkış milinde izin verilen radyal yükler [N]

$F_{qem}$ .....: Giriş milinde izin verilen radyal yükler [N]

$F_{qa}$ .....: Çıkış miline gelen radyal yükler [N]

$F_{qe}$ .....: Giriş miline gelen radyal yükler [N]

$F_q$ .....: Radyal yönde çıkış miline gelen yükler [N]

$F_a$ .....: Eksenel yönde çıkış miline gelen yükler [N]

$i$ .....: Tahvil oranı

$J_{ext}$ .....: Motor miline indirgenmiş toplam dış atalet momenti [kgm<sup>2</sup>]

$M_2$ .....: Çıkış momenti [Nm]

$M_a$ .....: Anma momenti [Nm]

$n_1$ .....: Redüktör giriş mili devri [d/dak]

$n_2$ .....: Redüktör çıkış mili devri [d/dak]

$P_{eq}$ .....: Eşdeğer güç [kW]

$P_e$ .....: Nominal güç (Bak. Güç-Devir Tabloları) [kW]

$P_M$ .....: Tahrik edilecek makina için gerekli güç (Değişken yükler için eşdeğer güç alınır) [kW]

$t$ .....: Zaman [s]

$T_e$ .....: Eşdeğer moment [Nm]

#### Key of Symbols

$c_t$ .....: Coefficient of switch on time.

$f_s$ .....: Service factor

$F_{ama}$ .....: Permissible axial loads which can be applied to output shafts [kN]

$F_{ame}$ .....: Permissible axial loads which can be applied to input shafts [kN]

$F_{qam}$ .....: Permissible overhung loads which can be applied to output shafts [N]

$F_{qem}$ .....: Permissible overhung loads which can be applied to input shafts [N]

$F_{qa}$ .....: Overhung loads applied to the output shaft [N]

$F_{qe}$ .....: Overhung loads applied to the input shafts [N]

$F_q$ .....: Overhung loads on output shaft [N]

$F_a$ .....: Axial loads on output shaft [N]

$i$ .....: Transmission ratio

$J_{ext}$ .....: Total outside moment of inertia reduced to the motor shaft [kgm<sup>2</sup>]

$M_2$ .....: Output torque [N]

$M_a$ .....: Nominal torque [Nm]

$n_1$ .....: Input speed of gearbox [rpm]

$n_2$ .....: Output speed of gearbox [rpm]

$P_e$ .....: Equivalent power [kW]

$P_N$ .....: Nominal power (given on performance tables) [kW]

$P_M$ .....: Power consumption of the driven machine (for alternating power, refer to equivalent power) [kW]

$t$ .....: Time [s]

$T_e$ .....: Equivalent torque [Nm]

#### Erklärung der Bezeichnungen

$c_t$ .....: Koeffizient der Betätigung von Schalter

$f_s$ .....: Betriebsfaktor

$F_{ama}$ .....: Zulässige Axialkräfte auf Abtriebswelle [kN]

$F_{ame}$ .....: Zulässige Axialkräfte auf Antriebswelle [kN]

$F_{qam}$ .....: Zulässige Querkräfte auf Abtriebswelle [N]

$F_{qem}$ .....: Zulässige Querkräfte auf Antriebswelle [N]

$F_{qa}$ .....: Querkräfte auf Abtriebswelle [N]

$F_{qe}$ .....: Querkräfte auf Antriebswelle [N]

$F_q$ .....: Querkräfte auf Abtriebswelle [N]

$F_a$ .....: Axialkräfte auf Abtriebswelle [N]

$i$ .....: Übersetzungsverhältnis

$J_{ext}$ .....: Die Gesamtträgheit der rotierende Teile von der Ausgangsseite reduziert auf Motorwelle [kgm<sup>2</sup>]

$M_2$ .....: Ausgangsdrehmoment [N]

$M_a$ .....: Nenndrehmoment [Nm]

$n_1$ .....: Antriebsdrehzahl [U/min]

$n_2$ .....: Abtriebsdrehzahl [U/min]

$P_e$ .....: Äquivalente Leistung [kW]

$P_N$ .....: Getriebe Nennleistung (siehe Leistung-Drehzahltabellen) [kW]

$P_M$ .....: Benötigte Leistung an der Abtriebswelle (Zur Berechnung bei variablen Leistungen äquivalente Leistung benutzen) [kW]

$t$ .....: Zeit [s]

$T_e$ .....: Minimales Drehmoment [Nm]



# Genel Bilgiler

## General Information

### Einführung



#### Ürün Yelpazesi

Elinizdeki katalog sadece **K serisi** ürünleri içermektedir.

##### - M ve N Serisi

Helisel alın dişliye sahip, giriş ve çıkış milleri aynı düzlem üzerinde ve birbirine paralel uzanan, üzerlerinde bulunan ayak veya flanş ile makina-ya sabitlenen redüktörlerdir. Dolu mil çıkışlıdır.

##### - D Serisi

Helisel alın dişliye sahip, giriş ve çıkış milleri aynı düzlem üzerinde, birbirine paralel ve belirli bir aralıkta yerleştirilmiş, iki yan yüzde bulunan bağlantı civataları, flanş veya tork kolu ile makina-ya sabitlenen redüktörlerdir. Delik milli veya mil çıkışlı olabilir.

##### - E Serisi

Sonsuz vida ve çark dişlili, belirli bir aralıkta ve birbirine dik konumlandırılmış giriş ve çıkış millerine sahip, çepçevre konumlandırılmış ayak bağlantıları, flanş veya tork kolu ile makina-ya sabitlenen redüktörlerdir. Delik milli veya mil çıkışlı olabilir.

##### - Y Serisi

Yatık tip redüktörler, ağır şartlarda çalışmak üzere dizayn edilmiş redüktör tipleridir. Bu tiplerde redüktör ile bunu tahrik eden mekanizma arasında değişik bağlantı şekilleri mevcuttur (Mekanik ve hidrolik kaplinler, çeşitli tip kayışlar ve zincirle tahrik gibi). Delik milli veya mil çıkışlı olabilir.

##### - K Serisi

Helisel alın dişli ve konik dişlilerden oluşan, birbirine dik ve belirli bir aralıkta konumlandırılmış giriş ve çıkış milline sahip, çepçevre sunulan ayaklar, flanş veya tork kolu ile makina-ya sabitlenen redüktörlerdir. E serisinden farklı olarak yüksek verime sahiptirler. Delik milli veya mil çıkışlı olabilir.

##### - H ve B Serisi

Helisel ve/veya konik dişliye sahip ağır hizmet tipi redüktörlerdir. Giriş ve çıkış milleri birbirine paralel veya dik olabilir. Her yönden bağlantı için ayak bağlantıları bulunur. Opsiyonel olarak flanş ile de bağlanabilir. Delik milli veya mil çıkışlı olabilir.

##### - T Serisi

T Serisi redüktörler helisel dişli iki kademe motorsuz delik milli redüktörlerdir. T Serisi redüktörler delik milli olması ve kompakt gövde yapısı sayesinde daha küçük hacimli alanlara montajı yapılabilmektedir.

##### - P ve R Serisi

P ve R Serisi redüktörler planet dişli redüktörlerdir. Endüstriyel ve mobil uygulamalarda kullanılırlar. Diğer redüktör tiplerine göre daha küçük hacimde daha büyük tork iletebilirler.

##### - VR Serisi

VR vinç redüktörleri M1 - M8 (1Dm - 5m) yük sınıflarına uygun olarak, çift veya sabit devirli frenli motorlarla üretilebilmektedir.

#### Production Range

*This catalogue is containing K series of gearboxes only.*

##### - M and N Series

*M and N series of YILMAZ REDÜKTÖR are helical geared. The input and output shafts are parallel to each other and on the same plane. The gearbox can be connected to the machine by using the foot or flange on the gearbox. Has solid output shaft.*

##### - D Series

*D series are helical geared gearboxes with parallel input and output shafts. The shafts have a distance in between and located on the same plane. The gearbox can be assembled to the machine by using the foot, the connection screws on the sides, flange or torque arm on the gearbox. Can have hollow or solid output shaft.*

##### - E Series

*E series gearboxes are with worm and worm-wheel. The input and output shafts are perpendicular to each other and have a distance in between. It can be assembled to the driven machine by the use of the foot, flange or torque arm on the gearbox. Can have hollow or solid output shaft.*

##### - Y Series

*Horizontal type gearboxes are designed to operate in heavy conditions. In these types there are a lot of combination forms between gearbox and driver (for example, mechanic and hydraulic couplings, various belt and chain drives etc.). Can have hollow or solid output shaft.*

##### - K Series

*These are gearboxes with helical and bevel gears. The input and output shafts are perpendicular to each other and have a distance in between. It can be assembled to the driven machine using the foot, flange or torque arm on the gearbox. They have high efficiency compared to E series. Can have hollow or solid output shaft.*

##### - H and B Series

*These gearboxes are helical or/and bevel geared industrial gearboxes. The input and output shafts can be arranged parallel or perpendicular to each other. The gearbox can be assembled by the use of the foot connections on each side. Flange connections are optional. Can have hollow or solid output shaft.*

##### - T Series

*T Series are gear units which are helical geared, two staged, hollow shaft mounted gear units and manufactured according to monoblock principal. T Series gearboxes have hollow shaft and compact housing so that T series can be mounted on smaller places.*

##### - P and R Series

*P and R Series gearboxes are planetary gearboxes. They are mostly used by industrial and mobile applications. Planetary gearboxes can transfer high torques in small volumes compared to other gearboxes.*

##### - VR Serie

*VR hoist drives are produced according to M1 - M8 (1Dm - 5m) load classification.*

#### Produktpalette

Dieses Katalog umfasst nur die **K Serien** Getriebe.

##### - M und N Serie

Diese Modelle sind Stirnradgetriebe mit parallelen Antriebs- und Abtriebswelle auf einer Ebene. Die Getriebe werden mit Fuß- oder Flanschverbindung an die angetriebene Maschine angekoppelt. Hat Vollwelle am Ausgang.

##### - D Serie

Diese Getriebe sind Stirnradgetriebe mit paralleler Antriebs- und Abtriebswelle, die auf einer Ebene liegen und einen Abstand zueinander haben. Diese Getriebe wird seitlich mit Gewindelöchern am Maschine oder mit einer Flansch verbindet. Kann Voll- und Hohlwelle am Ausgang haben.

##### - E Serie

Diese Getriebe bestehen aus Schnecke und Schneckenrad. Die Antriebs- und Abtriebswellen sind senkrecht zueinander und haben einen bestimmten Abstand. Das Getriebe wird mit Fußbefestigung, Flanschverbindung oder mit Drehmomentstütze an die angetriebene Maschine montiert. Kann Voll- und Hohlwelle am Ausgang haben.

##### - Y Serie

Diese Getrieben sind für Einsatz unter schweren Bedingungen ausgelegt. Bei dieser Ausführung gibt es sehr viele verschiedene Verbindungsmöglichkeiten zwischen Antrieb und Getriebe (Zum Beispiel; mechanische und hydraulische Kupplungen, Riemtrieb, Kettentrieb usw.). Kann Voll- und Hohlwelle am Ausgang haben.

##### - K Serie

Diese Getrieben bestehen aus Stirnräder und Kegelhäder. Die Antrieb und Abtriebswellen sind senkrecht und haben einen Abstand zueinander. Das Getriebe wird mit Fußbefestigung, Flanschverbindung oder Drehmomentstütze an die angetriebene Maschine montiert. Der Wirkungsgrad ist wesentlich höher als E Serie. Kann Voll- und Hohlwelle am Ausgang haben.

##### - H und B Serie

Diese Getriebe sind geeignet für industrielle Anwendungen und haben parallelen oder senkrechten Antrieb und Abtriebswelle auf einer Ebene. Das Getriebe kann mit Füßen, die auf jede Seite der Getriebe vorhanden sind, oder optional mit Flansch an die angetriebene Maschine montiert werden. Kann Voll- und Hohlwelle am Ausgang haben.

##### - T Serie

TSerien Getriebe sind zwei stufige, schrägverzahnte Hohlwellenflachgetriebe in Monoblockgehäuse. Die T Serie hat eine kompakte Gehäuse und ist serienmäßig mit Abgangshohlwelle hergestellt, so dass das Getriebe minimalen Platzbedarf hat.

##### - P und R Serie

P und R Serie sind Planetengetriebe, die vielseitig im Industrie und bei mobiler Anwendungen einsetzbar sind, mit Planetenzahnräder. Planetengetriebe können im Vergleich zu anderen Getrieben größere Drehmomente bei kleineren Bauvolumen übertragen.

##### - VR Serie

VR Krane und Hebezeuge werden geeignet zur Belastungsart M1 - M8 (1Dm - 5m) hergestellt.



# Genel Bilgiler

## General Information

### Einführung



M ...

**13 farklı büyüklükte;**  
**Moment aralığı: 50 - 18.000 Nm**  
**Devir aralığı: 0,1 - 500 d/dak**  
13 different sizes:  
Torque range: 50 - 18.000 Nm  
Speed range: 0,1 - 500 rpm  
13 verschiedene Baugrößen:  
Drehmomentbereich: 50 - 18.000 Nm  
Drehzahlbereich : 0,1 - 500 U/min



N ...

**13 farklı büyüklükte;**  
**Moment aralığı: 50 - 18.000 Nm**  
**Devir aralığı: 0,1 - 500 d/dak**  
13 different sizes:  
Torque range: 50 - 18.000 Nm  
Speed range: 0,1 - 500 rpm  
13 verschiedene Baugrößen:  
Drehmomentbereich: 50 - 18.000 Nm  
Drehzahlbereich : 0,1 - 500 U/min



E ...

**8 farklı büyüklükte;**  
**Moment aralığı: 5 - 1.000 Nm**  
**Devir aralığı: 0,1 - 400 d/dak**  
8 different sizes:  
Torque range: 5 - 1.000 Nm  
Speed range: 0,1 - 400 rpm  
8 verschiedene Baugrößen:  
Drehmomentbereich: 5-1.000 Nm  
Drehzahlbereich : 0,1-400 U/min



K ...

**7 farklı büyüklükte;**  
**Moment aralığı: 200 - 15.000 Nm**  
**Devir aralığı: 0,1 - 400 d/dak**  
7 different sizes:  
Torque range: 200 - 15.000 Nm  
Speed range: 0,1 - 400 rpm  
7 verschiedene Baugrößen:  
Drehmomentbereich: 200 - 15.000 Nm  
Drehzahlbereich : 0,1 - 400 U/min



D ...

**10 farklı büyüklükte;**  
**Moment aralığı: 130 - 18.000 Nm**  
**Devir aralığı: 0,1 - 350 d/dak**  
10 different sizes:  
Torque range: 130 - 18.000 Nm  
Speed range: 0,1 - 350 rpm  
10 verschiedene Baugrößen:  
Drehmomentbereich: 130 - 18.000 Nm  
Drehzahlbereich : 0,1 - 350 U/min



Y ...

**25 farklı büyüklükte;**  
**Moment aralığı: 1200 - 43000 Nm**  
**Devir aralığı: 2,6 - 990 d/dak**  
25 different sizes:  
Torque range: 1200 - 43000 Nm  
Speed range: 2,6 - 990 rpm  
25 verschiedene Baugrößen:  
Drehmomentber. : 1200-43000 Nm  
Drehzahlbereich : 2,6-990 U/min



H ...

**13 farklı büyüklükte;**  
**Moment aralığı: 2.500 - 150.000 Nm**  
**Devir aralığı: 0,1 - 250 d/dak**  
14 different sizes:  
Torque range: 2.500 - 150.000 Nm  
Speed range: 0,1 - 250 rpm  
14 verschiedene Baugrößen:  
Drehmomentber. : 2.500 - 150.000 Nm  
Drehzahlbereich : 0,1 - 250 U/min



B ...

**13 farklı büyüklükte;**  
**Moment aralığı: 5.000 - 150.000 Nm**  
**Devir aralığı: 0,1 - 115 d/dak**  
13 different sizes:  
Torque range: 5.000 - 150.000 Nm  
Speed range: 0,1 - 115 rpm  
13 verschiedene Baugrößen:  
Drehmomentber. : 5.000-150.000 Nm  
Drehzahlbereich : 0,1-115 U/min



P ...

**10 farklı büyüklükte;**  
**Moment aralığı: 1.000 - 50.000 Nm**  
**Tahvil oranları: 3,5 - 3000 arası**  
10 different sizes:  
Torque range: 1.000 - 50.000 Nm  
Transmission ratio: 3,5 - 3000  
10 verschiedene Baugrößen:  
Drehmomentber. : 1.000 - 50.000 Nm  
Übersetzung: 3,5 - 3000



R ...

**10 farklı büyüklükte;**  
**Moment aralığı: 1.000 - 50.000 Nm**  
**Tahvil oranları: 3,5 - 3000 arası**  
10 different sizes:  
Torque range: 1.000 - 50.000 Nm  
Transmission ratio: 3,5 - 3000  
10 verschiedene Baugrößen:  
Drehmomentber. : 1.000 - 50.000 Nm  
Übersetzung: 3,5 - 3000



T ...

**10 farklı büyüklükte;**  
**Moment aralığı: 200 - 18.000 Nm**  
**Devir aralığı: 46 - 280 d/dak**  
10 different sizes:  
Torque range: 200-18.000 Nm  
Speed range: 46-280 rpm  
10 verschiedene Baugrößen:  
Drehmomentber. : 200-18.000 Nm  
Drehzahlbereich : 46-280 U/min



VR ...

**VR vinç redüktörleri**  
**M1 - M8 ,(1Dm - 5m) yük sınıfı**  
**ISO 4301 / 1 ,(FEM 1.001 / III)**  
VR Hoist Drive Units  
M1 - M8 ,(1Dm - 5m) load classification  
ISO 4301 / 1 ,(FEM 1.001 / III)  
VR Kran und Hebezeug Getriebe  
M1 - M8 ,(1Dm - 5m) Belastungsart  
ISO 4301 / 1 ,(FEM 1.001 / III)



# Genel Bilgiler

## General Information

### Einführung



#### K Serisi Redüktörlerin Genel Özellikleri

K Serisi redüktörler, helisel konik dişli monoblok gövde yapısındaki redüktörlerdir. Giriş ve çıkış milleri 90° olması gereken durumlarda yüksek verim ve mukavemetin gerektirdiği yerler için dizayn edilmiştir.

K Serisi redüktörler E serisinin çok yönlü bağlantı opsiyonları ile M serisinin monoblok ve yüksek verim özellikleriyle birlikte yüksek momente sahip olarak üretilmektedir. Redüktörlerin giriş motor bağlantılarında IEC B5 veya B14, standart akuple veya motorsuz mil girişi gibi esnek montaj opsiyonları kullanılmaktadır.

Helisel konik dişli redüktörler monoblok gövde içerisinde 3 kademe olarak üretilebilmektedir. Yüksek redüksiyon gerektiren yerlerde 6 kademe kadar akuple edilerek temin edilebilir.

YILMAZ REDÜKTÖR olarak tasarım prensibimiz;

- Yüksek teknoloji kullanmak
- Güvenilirlik,
- Yüksek güç yoğunluğu,
- Yüksek verim,
- Montaj uyumluluğu,
- Esnek çözümler

#### Dikkat Edilecek Hususlar !

- Bu katalogta verilen resimler görsel amaçlıdır ve şekilsel detaylar bağlayıcı değildir.

- YILMAZ REDÜKTÖR, ürünler ve kataloglar üzerinde, müşterileri bilgilendirmeksizin her türlü değişikliği yapma hakkına sahiptir.

- Ürünler teslim alındıktan sonra ürünle birlikte verilen kullanım kılavuzu okunmadan sistem devreye alınmamalıdır.

- Katalogta verilen yağ miktarları referans amaçlıdır. Gerçek yağ seviyesi için redüktör üzerinde bulunan yağ seviye tapası kullanılmalıdır. Yağ viskozitesi için, redüktör etiketine bakınız.

- Sipariş anında montaj pozisyonu bildirilmeyen redüktörler **M1** montajına uygun sevk edilir. Etiketle yazan montaj pozisyonundan farklı bağlanan redüktörler garanti kapsamından çıkar. Bu katalogta verilen redüktör ağırlıkları ortalama ağırlık değerleridir. Tahvil oranına ve üzerinde bağlı olan aksesuara göre ağırlıklar farklılık gösterebilir.

#### General Specifications of K Series Gearboxes

*K Series gearboxes are helical-bevel geared monoblock housing gearboxes. K Series are designed for higher efficiency and higher strenght required operations. Input and output shafts are perpendicular to each other.*

*K Series gearboxes have advantages of E Series mounting options, monoblock housing and higher efficiency advantages of M series with higher torque capabilities. K Series have flexible connection possibilities which is IECB5 or B14 connection, directly mounted or solid input shaft options .*

*Helical- Bevel gearboxes can be manufactured only 3 stages in monoblock housing. K series supplied for high reduction operations up to 6 stages by using double housings.*

*As we are YILMAZ REDÜKTÖR,our design principals are;*

- Using high technology
- Reliability
- High power density
- High efficiency
- Mounting compatible
- Flexible solutions

#### Attention to the following points !

*- Drawings are examples only and the details on the drawings or illustrations are not strictly binding.*

*- YILMAZ REDÜKTÖR reserve the right to make all kinds of changes in products and catalogues without any notice.*

*- Prior to commissioning, the operating instructions provided with the gearbox must be observed.*

*- Oil quantities given are guide values only. The exact quantity of oil should be checked by using the provided oil level plugs according mounting positions. For correct oil viscosity refer to the nameplate.*

*- If the mounting position is not informed upon ordering, the gear unit is delivered according **M1** mounting position. A different operation then the indicated mounting position on the name plate cancels the warranty. The weights given in this catalogue are mean values. Depending on the ratio and accessories the weights can differ.*

#### Allgemeine Eigenschaften von K Serie Getrieben

K Serie Getriebe sind Kegelaradgetriebe mit Monoblok-Gehäuse. Eingang- und Ausgangswelle sind senkrecht zueinander. Diese Getriebe sind für Einsätze, wo hohe Wirkungsgrad und Festigkeit benötigt wird, konstruiert.

K Serie Getriebe haben umfangreiche Montagemöglichkeiten, wie E Serie, hohe Momenttragbarkeit mit hohem Wirkungsgrad und Monoblok-Gehäuse, wie M Serie, als Vorteil. Standart Motorverbindung (IEC B14 oder B5) oder Wellenantrieb ist möglich.

Kegelradgetriebe können nur maximal mit 3 Stufen in einem Gehäuse hergestellt werden. K Serie Getriebe werden für hohe Untersetzungen mit Hilfe von zusätzlichem Gehäuse bis zu 6 Stufen ausgeführt.

Als YILMAZ REDÜKTÖR unsere Entwurfsprinzipien sind;

- Verwenden von hohen Fertigungstech.
- Hohe Betriebssicherheit
- Leistungsdichte
- Hoher Wirkungsgrad
- Universale Montagemöglichkeit
- Sonderlösungen

#### Bitte folgende Punkte beachten !

- Die Abbildungen sind beispielhaft und nicht verbindlich.

- Alle-Änderungen auf dem Katalog und an der Produkte bleiben vorbehalten und können ohne Kenntnisnahme erfolgen.

- Vor Inbetriebnahme ist die mit gelieferter Betriebsanleitung zu beachten.

-Angaben über Ölmengen sind unverbindlich. Maßgebend ist die Ölstandsschraube in der geeigneten Montageposition. Ölviskosität und Sorte muss den Angaben des Typenschildes entsprechen.

- Wenn die Bauform bei Bestellung nicht angegeben ist, erfolgt die Lieferung in der Bauform **M1**. Wenn die Getriebe anders als auf dem Typenschild benannte Bauform eingesetzt werden, verliert die Garantie ihre Gültigkeit. Die angegebenen Gewichte sind unverbindliche Mittelwerte ohne Zubehör; genauere Gewichte sind abhängig von Zubehör und Übersetzung.



# Genel Bilgiler

## General Information

### Einführung



#### Teknik Tanımlamalar

##### - Çıkış Momenti $M_2$ : [Nm]

Motorun verdiği momentin tahvil oranı ve verimle ile çarpılarak elde edilen değerdir. Redüktörün çıkışından alınabilecek moment gösterir.

##### - Anma Momenti $M_a$ : [Nm]

Redüktörün  $f_s=1$  şartı için mekanik olarak taşıdığı moment değeridir.

##### - Nominal Güç $P_e$ : [kW]

Nominal güç, redüktörün  $f_s=1$  şartı için mekanik olarak taşıyabileceği güç değeridir. Redüktörlerin nominal güçleri, motorsuz güç devir tablolarında verilmiştir.

##### - Çevrim oranı i:

Redüktörün giriş devrinin çıkış devrine oranıdır. Yılmaz Redüktör K serisi redüktörlerde 5-13000 arasında değişen çevrim oranları mevcuttur.

##### - Eşdeğer Güç ve Moment

$P_{eq}$  [kW],  $T_e$  [Nm]

Sabit devir altında ancak değişken yük değerlerinde çalışan redüktörlerde, sabit yük altında çalışma şartlarına eşdeğer gelen moment ve güç değerleridir. Hesaplama yöntemi sayfa 26'de verilmiştir.

##### - İhtiyaç güç $P_M$ : [kW]

Redüktörlerin kullanılacağı uygulamanın istenilen şekilde çalışabilmesi için ihtiyaç duyduğu güç değeridir.

##### - İhtiyaç moment T: [Nm]

Redüktörün kullanılacağı uygulamanın çalışabilmesi için ihtiyaç duyduğu moment değeridir. Seçilen redüktör için her zaman çıkış momentini eşit yada daha düşük olmalıdır.

##### - Müsade Edilen Eksenel ve Radyal Yükler

$F_{qem}$ ,  $F_{qam}$ : [N]

Redüktörün üzerine gelebilecek çalışma esnasında giriş veya çıkış millerinde müsade edilen eksenel ve radyal yüklerdir.

##### - Servis Faktörü $f_s$ :

Redüktörün çalıştığı şartlar ile uyumlu olması için gerekli olan emniyet katsayısıdır.  $f_s=1$ , düzgün ve sakin yüklerde, günlük sekiz saat, saatte 100 dur-kalk çalışmayı karşılar. Detaylar için redüktör seçim bölümüne bakınız.

#### Teknik Özellikler:

##### - Ses seviyesi:

Redüktörlerimizin ses seviyesi VDI 2159' da verilen redüktörler için müsade edilen ses seviyelerinin altındadır.

##### - Boya ve Korozyon Koruması:

Redüktörlerin standart rengi DIN1843'e göre RAL 7031 dir. İstek üzerine farklı renklerde boyanabilir. Nemli ve korozyon bölgeler için istek üzerine farklı boya uygulanabilir.

#### Technical Explanations

##### - Output Torque $M_2$ : [Nm]

Multiplication of motor output torque with transmission ratio and efficiency the result gives output torque at the output of gearbox unit.

##### - Nominal Moment $M_a$ : [Nm]

Nominal torque is mechanically torque of gearboxes under  $f_s=1$  conditions.

##### - Nominal Powers $P_e$ : [kW]

The nominal powers are the powers which gearbox can mechanically resist under  $f_s=1$  condition. The nominal powers are given on the gear unit performance tables.

##### - Ratio i:

Ratio between output shaft speed and input shaft speed. Available ratios of Yılmaz Redüktör K series are between 5 to 13000

##### - Equivalent Power and Torque

$P_{eq}$ : [kW],  $T_e$ : [Nm]

For gearbox unit with constant speed but variable working conditions calculated Power and Torque equivalent to the values at working under constant working conditions.

##### - Required Power $P_M$ : [kW]

For gearbox unit required power, which has to be guaranteed at work by applications for this gearbox unit.

##### - Required Torque T: [Nm]

Required torque for applications. Required torque always must be equal or smaller than output torque for selected gearbox.

##### - Permissible Axial and Overhung Loads:

$F_{qem}$ ,  $F_{qam}$  [N]

Permissible axial and overhung load of output or input shaft for applications.

##### - Service Factor $f_s$ :

Service factor is a safety coefficient, which takes into account the different running conditions of the driven machine.  $f_s=1$  is used for uniform loads 8 hours working per day and up to 100 cycle per hour.

#### Technical Specifications:

##### - Noise Level:

The noise level of our gearboxes is below the permitted values defined in VDI guidelines 2159 for gear units.

##### - Coating and Corrosion Protection:

The gearboxes are painted with RAL 7031 according DIN1843. Different colours are available upon request. As request of painting for high humidity or chemically aggressive environments available.

#### Technische Erläuterungen

##### - Ausgangsmoment $M_2$ : [Nm]

Multiplikation von Ausgangsmoment des Motors mit Übersetzung und Division das Ergebnis mit Wirkungsgrad ergibt den Betrag von Ausgangsmoment der Getriebe.

##### - Nennmoment $M_a$ : [Nm]

Mechanisches Belastungsmoment der Getriebe unter dem Bedingung  $f_s=1$ .

##### - Nennleistung $P_e$ : [kW]

Die Nennleistung ist die mechanische Grenzfestigkeitsleistung für  $f_s=1$ . Kann von der Leistung- Drehzahltable abgelesen werden.

##### - Übersetzung i:

Wird aus dem Verhältnis von Ausgang- zu Eingangswinkelgeschwindigkeit bestimmt. Gängige Übersetzungen von Yılmaz K Serie Getriebe liegt zwischen 5,2 bis 13000.

##### - Äquivalente Leistung und Moment

$P_{eq}$ : [kW],  $T_e$ : [Nm]

Für mit konstanten Drehzahl aber unter veränderlichen Betriebsbedingungen arbeitende Getriebe berechnete Leistung und Moment äquivalent zu Werten beim Arbeiten unter konstanten Betriebsbedingungen.

##### - Notwendige Leistung $P_M$ : [kW]

Für das Getriebe notwendige Leistung, um Arbeiten von Getriebe bei der für das Getriebe gedachten Anwendung zu gewährleisten.

##### - Notwendige Moment T: [Nm]

Notwendige Moment für Anwendungen. Für den ausgewählte Getriebe soll das notwendige Moment gleich dem Ausgangsmoment oder kleiner als diesem Moment sein.

##### - Zulässige Axial- oder Querkräfte:

$F_{qem}$ ,  $F_{qam}$  [N]

Bei der Anwendungen während der Betrieb zulässige axiale oder radiale Eingangs- oder Ausgangsbelastungen.

##### - Betriebsfaktor $f_s$ :

Dieser Faktor  $f_s$  ist ein Sicherheitsfaktor, damit die Getriebe unter verschiedenen Bedingungen mit genügender Sicherheit arbeitet.  $f_s=1$  gilt für gleichförmig Belastung, mit 8 Betriebsstunden pro Tag und bis zum 100 Schaltungen pro Stunde.

#### Technische Informationen:

##### - Geräuschpegel:

Geräuschstärken aller Getriebe bleiben unter die zulässigen Werte, die für die Getriebe in der VDI-Richtlinie 2159 festgelegt sind.

##### - Lackierung und Korrosionsschutz:

Die Getriebe werden mit der Farbe RAL 7031 nach DIN1843 lackiert. Auf Wunsch sind Sonderlackierungen möglich. Alle Getriebe können auf Wunsch auch in korrosionsschutzter Ausführung für aggressive Umgebungen geliefert werden.



## Genel Bilgiler General Information Einführung



### - Yağlama:

K Serisi redüktörler yağlama tablolarında verilen yağlar ile doldurulmaktadır. Yağ detayları için yağlama bölümüne bakınız.

### - Aksesuarlar:

K Serisi redüktörlerde aşağıdaki aksesuarlar kullanılabilir

- IEC B5 Motor bağlantı flanşları
- Çıkış Bağlantı Flanşları
- Sıkma bileziği
- Geri dönüş kilidi
- Özel keçe çözümleri,
- Şeffaf yağ seviye göstergesi
- Tork kolu
- Elektromanyetik frenler

Diğer özel aksesuarlar için lütfen, YILMAZ REDÜKTÖR ile temasa geçiniz.

### - Lubrication:

*K series of gearboxes filled with oils which are indicated on lubrication tables. For lubrication details please refer to the lubrication section.*

### - Accessories:

*The following accessories can be applied to K series gearboxes.*

- IEC B5 Motor connection flange
- Output flanges
- Shrink Discs
- Backstops
- Special sealing solutions.
- Transparent oil level indicator,
- Torque arm
- Electromagnetic brakes.

*For other accessories please contact, YILMAZ REDÜKTÖR.*

### - Schmierung:

K Serie Getriebe werden mit Ölen entsprechend der Schmierungstabellen, falls nicht anders vereinbart, geliefert. Für weitere Schmierungsangaben siehe Kapitel Schmierung.

### - Zubehör:

Folgendes Zubehör kann für Getriebe der K Serie geliefert werden.

- IEC B5 Motor Adapter,
- Abtriebsflansch,
- Schrumpfscheiben,
- Rücklaufsperrn,
- Unterschiedliche Dichtungssysteme,
- Ölstandzeiger
- Drehmomentstütze
- Elektromagnetische Bremsen

Für weiteres Zubehör kontaktieren Sie bitte mit, YILMAZ REDÜKTÖR.







**Genel Bilgiler**  
*General Information*  
Einführung





# Genel Bilgiler General Information Einführung



Tip Tanımlaması / Unit Designation / Typenbezeichnung

**K R 3 7 3 . 02 - 90S/4 - L05**

### Fren / Brake / Bremse

L-220V <b>Fanlı</b> / <i>With Fan</i> / Mit Lüfter	<b>01</b> -10 Nm	<b>10</b> -100 Nm
P-24V <b>Fanlı</b> / <i>With Fan</i> / Mit Lüfter	<b>02</b> -25 Nm	<b>20</b> -200 Nm
S-220 V <b>Fansız</b> / <i>Without Fan</i> / Ohne Lüfter	<b>04</b> -40 Nm	<b>30</b> -300 Nm
Z-24 V <b>Fansız</b> / <i>Without Fan</i> / Ohne Lüfter	<b>05</b> -50 Nm	<b>40</b> -400 Nm

### Motor Büyüklüğü / Motor Size / Motorbaugröße

KV Tipleri için / For KV types / Für typen KV

KN tipleri için / For KN Types / Für Typen KN

90 S / 4

Kutup Sayısı / Pole Number /

Anzahl der polen

Gövde uzunluğu / Frame Length /

Gehäuselänge

Motor büyüklüğü / Motor size /

Motorbaugröße

**A06** : 63 B5 **A10** : 100 B5 **A20** : 200 B5

**B06** : 63 B14 **B10** : 100 B14 **A22** : 225 B5

**A07** : 71 B5 **A11** : 112 B5 **A25** : 250 B5

**A08** : 80 B5 **A13** : 132 B5 **A31** : 315 B5

**B08** : 80 B14 **B13** : 132 B14

**A09** : 90 B5 **A16** : 160 B5

**B09** : 90 B14 **A18** : 180 B5

### Çıkış Özelliği / Output Specification / Eigenschaft der Ausgang

**00** :Standart delik milli / *Hollow shaft output* / Standarte Ausführung mit Hohlwelle

**01** :Mil Çıkışlı / *Solid output shaft* / Vollwelle

**02** :Flanşlı ve mil çıkışlı / *Solid output shaft and with Flange* / Mit Flansch und Abtriebsvollwelle

**03** :Flanşlı ve delik milli çıkışlı / *Flanged and hollow shaft output* / Mit Flansch und Hohlausgangswelle

**04** :Çift çıkış milli / *With Double shaft output* / Mit doppelte Abtriebswelle

**05** :Çift flanşlı ve çift çıkış milli / *Double flanged and double output shaft* / Mit doppelte Flansch un f doppelte Abtriebswelle

**08** :Çift flanşlı delik milli / *Double flanged and hollow output shaft* / Doppelte Flansch und Aufsteckenwelle

**0S** :Sıkma Bilezikli / *Shrink disk output* / Schrumpfscheibe

**0E** :Ekstruder Çıkışlı / *Extruder output* / Extruder-Ausgang

### Kademe Sayısı / Stage / Anzahl der Stufen

**3 kademe** / 3 Stages / 3 Stufig

**4 kademe** / 4 Stages / 4 Stufig

**5 kademe** / 5 Stages / 5 Stufig

**6 kademe** / 6 Stages / 6 Stufig

### Revizyon Numarası / Revision Number / Änderungsnummer

### Gövde Büyüklük / Housing Size / Größe von Gehäuse

2...8

### Giriş Tipi / Input Type / Eingangstyp

**R** :Motorlu / *With Motor* / Mit Motor

**N** :Motorsuz ve IEC B5/B14 Flanş girişli / *IEC B5 / B14 Flanged without Motor* / Ohne Motor und mit IEC B5/B14 Eingangsflansch

**V** :Motorlu ve IEC B5/B14 Flanş girişli / *IEC B5 / B14 Flanged with Motor* / Mit Motor und IEC B5/B14 Eingangsflansch

**T** :Motorsuz / *Without Motor* / Eingang mit Vollwelle ohne Motor

### Redüktör Tipi / Gearbox Type / Getriebe

**K Serisi** / *K Serie* / K Serie



# Genel Bilgiler

## General Information

### Einführung



#### Tip Tanımlaması / Unit Designation / Typenbezeichnung

KR..00..	<b>Konik-Helisel tip redüktörler, motor bağlantılı, delik milli çıkış / Bevel-Helical type geared motors, Direct coupled motor, Hollow shaft output /</b> Flachgetriebemotoren, Verbunden mit Motor, Ausgang mit Hohlwelle.
KR..01..	<b>Konik-Helisel tip redüktörler, motor bağlantılı, milli çıkış / Bevel-Helical type geared motors, Direct motor coupled, solid output shaft /</b> Flachgetriebemotoren, Verbunden mit Motor, Ausgang mit Vollwelle.
KR..02..	<b>Konik-Helisel tip redüktörler, motor bağlantılı, mil ve flanş çıkışlı / Bevel-Helical type geared motors, Direct motor coupled, Solid output shaft and output flange /</b> Flachgetriebemotoren, Verbunden mit Motor, Ausgang mit Vollwelle und Flansch.
KR..03..	<b>Konik-Helisel tip redüktörler, motor bağlantılı delik milli ve flanş çıkışlı / Bevel-Helical type geared motors, Direct motor coupled, Hollow output shaft and output flange /</b> Flachgetriebemotoren, Verbunden mit Motor, Ausgang mit Hohlwelle und Flansch.
KR..04..	<b>Konik-Helisel tip redüktörler, motor bağlantılı, çift çıkış milli / Bevel-Helical type gerboxes, Direct motor coupled, double output shaft, /</b> Flachgetriebemotoren, Verbunden mit Motor, mit doppelter Ausgangswelle
KR..05..	<b>Konik-Helisel tip redüktörler, motor bağlantılı çift milli ve çift flanş çıkışlı / Bevel-Helical type geared motors, Direct motor coupled, double hollow output shaft and double flange output. /</b> Flachgetriebemotoren, Verbunden mit Motor, Ausgang mit Hohlwelle und Flansch.
KR..08..	<b>Konik-Helisel tip redüktörler, motor bağlantılı delik milli ve çift flanş çıkışlı / Bevel-Helical type geared motors, Direct motor coupled, double hollow output shaft and double flange output. /</b> Flachgetriebemotoren, Verbunden mit Motor, Ausgang mit Hohlwelle und Flansch.
KR..0S..	<b>Konik-Helisel tip redüktörler, motor bağlantılı, sıkma bilezik çıkışlı / Bevel-Helical type geared motors Direct motor coupled, Shrink disk output /</b> Flachgetriebemotoren, Verbunden mit Motor, Ausgang mit Schrumpfscheibe
KR..0E..	<b>Konik-Helisel tip motorlu redüktörler, motor bağlantılı, ekstruder çıkışlı / Bevel-Helical type geared motors Direct motor coupled, extruder output /</b> Flachgetriebemotoren, Verbunden mit Motor, Ausgang mit Extruder
KN..00..	<b>Konik-Helisel tip redüktörler, IEC B5/B14 flanşlı motorsuz, delik milli çıkış / Bevel-Helical type gearboxes, IEC B5/B14 flanged input without motor, hollow output shaft /</b> Flachgetriebe, ohne Motor mit IEC B5/B14 Flansch, Ausgang mit Hohlwelle.
KN..01..	<b>Konik-Helisel tip redüktörler, IEC B5/B14 flanşlı motorsuz, mil çıkışlı / Bevel-Helical type gearboxes, IEC B5/B14 flanged input without motor, Solid output shaft /</b> Flachgetriebe, ohne Motor mit IEC B5/B14 Flansch, Ausgang mit Vollwelle.
KN..02..	<b>Konik-Helisel tip redüktörler, IEC B5/B14 flanşlı motorsuz, mil ve flanş çıkışlı / Bevel-Helical type gearboxes, IEC B5/B14 flanged input without motor, Solid output shaft and output flange /</b> Flachgetriebe, ohne Motor mit IEC B5/B14 Flansch, Ausgang mit Vollwelle und Flansch.
KN..03..	<b>Konik-Helisel redüktörler, IEC B5/B14 flanşlı motorsuz, delik milli ve flanş çıkışlı / Bevel-Helical type gearboxes, IEC B5/B14 flanged input without motor, Hollow output shaft and output flange /</b> Flachgetriebe, ohne Motor mit IEC B5/B14, Ausgang mit Hohlwelle und Flansch.
KN..04..	<b>Konik-Helisel tip redüktörler, IEC B5/B14 flanşlı motorsuz, çift çıkış milli / Bevel-Helical type gerboxes, IEC B5/B14 flanged without motor, double output shaft, /</b> Flachgetriebe, ohne Motor mit IEC B5/B14, mit doppelter Ausgangswelle
KN..05..	<b>Konik-Helisel tip redüktörler, IEC B5/B14 flanşlı motorsuz, çift milli ve çift flanş çıkışlı / Bevel-Helical type geared motors, IEC B5/B14 flanged input without motor, double hollow output shaft and flange output. /</b> Flachgetriebemotoren, Verbunden mit Motor, Ausgang mit Hohlwelle und Flansch.
KN..08..	<b>Konik-Helisel tip redüktörler, IEC B5/B14 flanşlı motorsuz, delik milli ve çift flanş çıkışlı / Bevel-Helical type geared motors, IEC B5/B14 flanged input without motor, double hollow output shaft and double flange output. /</b> Flachgetriebemotoren, Verbunden mit Motor, Ausgang mit Hohlwelle und Flansch.
KN..0S..	<b>Konik-helisel tip helisel redüktörler, IEC B5/B14 flanşlı motorsuz, sıkma bilezik çıkışlı / Bevel-Helical type geared motors IEC B5/B14 flanged without motor, Shrink disk Output /</b> Flachgetriebemotoren, ohne Motor mit IEC B5/B14, Ausgang mit Schrumpfscheibe
KN..0E..	<b>Konik-helisel tip helisel redüktörler, IEC B5/B14 flanşlı motorsuz, ekstruder çıkışlı / Bevel-Helical type geared motors IEC B5/B14 flanged without motor, extruder output /</b> Flachgetriebemotoren, ohne Motor mit IEC B5/B14, Ausgang mit Extruder.
KV..00..	<b>Konik-Helisel tip helisel redüktörler, IEC B5/B14 flanşlı, motorlu, delik milli çıkış / Bevel-Helical type gearboxes, IEC B5/B14 flanged input with coupled motor, hollow output shaft /</b> Flachgetriebe, Verbunden mit IEC B5/B14 Motorverbindung, Ausgang mit Hohlwelle.
KV..01..	<b>Konik-Helisel tip helisel redüktörler, IEC B5/B14 flanşlı, motorlu, mil çıkışlı / Bevel-helical type gearboxes, IEC B5/B14 flanged input with coupled motor, solid output shaft /</b> Flachgetriebe, Verbunden mit IEC B5/B14 Motorverbindung, Ausgang mit Vollwelle.
KV..02..	<b>Konik-Helisel tip helisel redüktörler, IEC B5/B14 flanşlı, motorlu, mil ve flanş çıkışlı / Bevel-helical type gearboxes, IEC B5/B14 flanged input with coupled motor, with solid output shaft and output flange /</b> Flachgetriebe, Verbunden mit IEC B5/B14 Motorverbindung, Ausgang mit Vollwelle und Flansch.
KV..03..	<b>Konik-Helisel tip helisel redüktörler, IEC B5/B14 flanşlı, motorlu, delik milli ve flanş çıkışlı / Bevel-helical type gearboxes, IEC B5/B14 flanged input with coupled motor, Hollow output shaft and output flange /</b> Flachgetriebe, Verbunden mit IEC B5/B14 Motorverbindung, Ausgang mit Hohlwelle und Flansch.
KV..04..	<b>Konik-Helisel tip redüktörler, motor bağlantılı, çift çıkış milli / Bevel-Helical type gerboxes, IEC B5/B14 flanged input with coupled motor, double output shaft, /</b> Flachgetriebe, Verbunden mit IEC B5/B14 Motorverbindung, mit doppelter Ausgangswelle
KV..05..	<b>Konik-Helisel tip helisel redüktörler, IEC B5/B14 flanşlı, motorlu, çift milli ve çift flanş çıkışlı / Bevel-helical type gearboxes, IEC B5/B14 flanged input with coupled motor, double output shaft and double output flange /</b> Flachgetriebe, Verbunden mit IEC B5/B14 Motorverbindung, Ausgang mit Hohlwelle und Flansch.
KV..08..	<b>Konik-Helisel tip redüktörler, IEC B5/B14 flanşlı, motorlu, delik milli ve çift flanş çıkışlı / Bevel-Helical type geared motors, IEC B5/B14 flanged input with direct coupled motor, double hollow output shaft and double flange output. /</b> Flachgetriebemotoren, Verbunden mit Motor, Ausgang mit Hohlwelle und Flansch.
KV..0S..	<b>Konik-Helisel tip redüktörler, IEC B5/B14 flanşlı motorlu, sıkma bilezik çıkışlı / Bevel-Helical geared motors IEC B5/B14 flanged with direct coupled motor, Shrink disk output /</b> Flachgetriebemotoren, Verbunden mit IEC B5/B14 Motorverbindung, Ausgang mit Schrumpfscheibe
KV..0E..	<b>Konik-Helisel tip helisel redüktörler, IEC B5/B14 flanşlı motorlu, ekstruder çıkışlı / Bevel-Helical geared motors IEC B5/B14 flanged with direct coupled motor, Extruder Output /</b> Flachgetriebemotoren, Verbunden mit IEC B5/B14 Motorverbindung, Ausgang mit extruder.
KT..00..	<b>Konik-Helisel tip helisel redüktörler, motorsuz ve mil girişli, delik milli çıkış / Bevel-Helical geared unit, Solid shaft input without motor, Hollow output shaft /</b> Flachgetriebe, Eingang mit Vollwelle ohne Motor, Ausgang mit Hohlwelle.
KT..01..	<b>Konik-Helisel tip helisel redüktörler, motorsuz ve mil girişli, mil çıkışlı / Bevel-Helical geared units, Solid shaft input without motor, Solid output shaft /</b> Flachgetriebe, Eingang mit Vollwelle ohne Motor, Ausgang mit Vollwelle.
KT..02..	<b>Konik-Helisel tip helisel redüktörler, motorsuz ve mil girişli, mil ve flanş çıkışlı / Bevel-Helical gear units, Solid shaft input without motor, Solid output shaft and flange output /</b> Flachgetriebe, Eingang mit Vollwelle ohne Motor, Ausgang mit Vollwelle und Flansch.
KT..03..	<b>Konik-Helisel tip helisel redüktörler, motorsuz ve mil girişli, delik milli ve flanş çıkışlı / Bevel-Helical gear units, solid shaft input without motor, Hollow output shaft and output flange /</b> Flachgetriebe, Eingang mit Vollwelle ohne Motor, Ausgang mit Hohlwelle und Flansch.
KT..04..	<b>Konik-Helisel tip redüktörler, motor bağlantılı, çift çıkış milli / Bevel-Helical type gerboxes, solid input shaft, double output shaft, /</b> Flachgetriebe, Eingang mit Vollwelle, mit doppelter Ausgangswelle
KT..05..	<b>Konik-Helisel tip helisel redüktörler, IEC B5/B14 flanşlı, motorsuz, çift milli ve çift flanş çıkışlı / Bevel-helical type gearboxes, IEC B5/B14 flanged input without motor, double output shaft and double output flange /</b> Flachgetriebe, Verbunden mit IEC B5/B14 Motorverbindung, Ausgang mit Hohlwelle und Flansch.
KT..08..	<b>Konik-Helisel tip redüktörler, IEC B5/B14 flanşlı, motorlu, delik milli ve çift flanş çıkışlı / Bevel-Helical type geared motors, IEC B5/B14 flanged input with without motor, double hollow output shaft and double flange output. /</b> Flachgetriebemotoren, Verbunden mit Motor, Ausgang mit Hohlwelle und Flansch.
KT..0S..	<b>Konik-Helisel tip helisel redüktörler, motorsuz, sıkma bilezik çıkışlı / Bevel-Helical gear motors, Solid shaft input without motor, Shrink Disk Output /</b> Flachgetriebe, ohne Motor, Ausgang mit Schrumpfscheibe
KT..0E..	<b>Konik-Helisel tip helisel redüktörler, motorsuz, ekstruder çıkışlı / Bevel-Helical gear motors, Solid shaft input without motor, Extruder Output /</b> Flachgetriebe, ohne Motor, Ausgang mit Extruder.



# Genel Bilgiler

## General Information

### Einführung

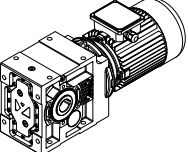
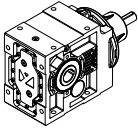
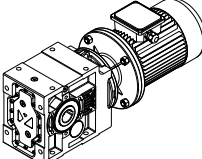
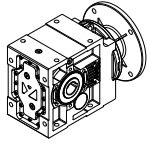
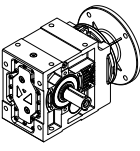
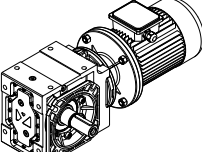
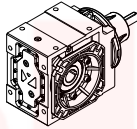
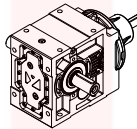
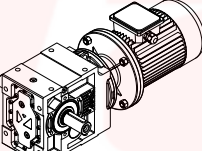
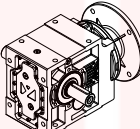
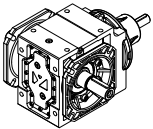
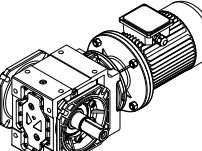
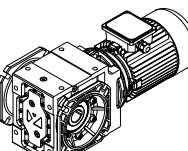
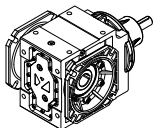
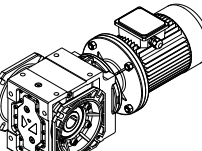
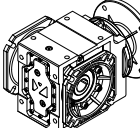
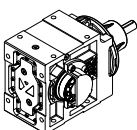
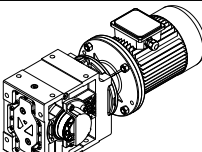
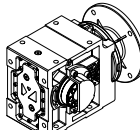
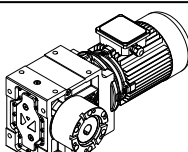
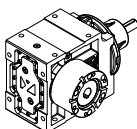
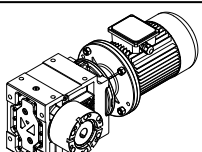

Tip Tanımlaması / Unit Designation / Typenbezeichnungen

 <b>KR..00</b>	 <b>KT..00</b>	 <b>KV..00</b>	 <b>KN..00</b>
 <b>KR..01</b>	 <b>KT..01</b>	 <b>KV..01</b>	 <b>KN..01</b>
 <b>KR..02</b>	 <b>KT..02</b>	 <b>KV..02</b>	 <b>KN..02</b>
 <b>KR..03</b>	 <b>KT..03</b>	 <b>KV..03</b>	 <b>KN..03</b>
 <b>KR..04</b>	 <b>KT..04</b>	 <b>KV..04</b>	 <b>KN..04</b>
 <b>KR..05</b>	 <b>KT..05</b>	 <b>KV..05</b>	 <b>KN..05</b>
 <b>KR..08</b>	 <b>KT..08</b>	 <b>KV..08</b>	 <b>KN..08</b>
 <b>KR..0S</b>	 <b>KT..0S</b>	 <b>KV..0S</b>	 <b>KN..0S</b>
 <b>KR..0E</b>	 <b>KT..0E</b>	 <b>KV..0E</b>	 <b>KN..0E</b>



# Genel Bilgiler

## General Information

### Einführung



#### Örnek Tip Tanımlamaları

##### KR273.00-90S/4-L05

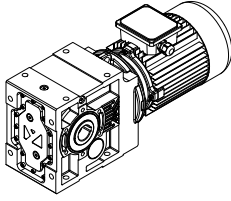

**K**.....: K serisi redüktör  
**R**.....: Motor bağlantılı  
**2**.....: Gövde büyüklük  
**7**.....: Revizyon numarası  
**3**.....: Kademe sayısı  
**00**.....: Delik mil çıkışı  
**90S/4**.....: Motor büyüklüğü  
**L05**.....: Fren Tipi

#### KT373.01

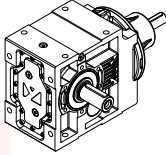

**K**.....: K serisi redüktör  
**T**.....: Motorsuz giriş milli  
**3**.....: Gövde büyüklüğü  
**7**.....: Revizyon numarası  
**3**.....: Kademe sayısı  
**01**.....: Mil çıkışı

#### KN473.03 - A11

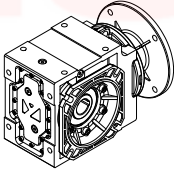

**K**.....: K serisi redüktör  
**N**.....: Motorsuz ve IEC B5 giriş flanşlı  
**4**.....: Gövde büyüklüğü  
**7**.....: Revizyon numarası  
**3**.....: Kademe sayısı  
**03**.....: Delik milli flanş bağlantılı çıkış  
**A11**.....: 112 tip motor, B5 bağlantı flanş

#### KV573.0S-100L/4

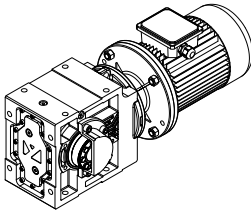

**K**.....: K serisi redüktör  
**V**.....: Motorlu ve B5/B14 giriş flanşlı  
**5**.....: Gövde büyüklüğü  
**7**.....: Revizyon numarası  
**3**.....: Kademe sayısı  
**0S**.....: Sıkma bilezikli delik milli çıkış  
**100L/4**.....: Motor büyüklüğü ve kutup sayısı

#### Sample Designations

##### KR273.00-90S/4-L05

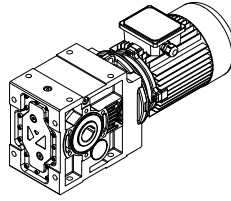

**K**.....: K serie of gearbox  
**R**.....: Direct motor coupled  
**2**.....: Gear unit size  
**7**.....: Revision number  
**3**.....: Stage number  
**00**.....: Hollow shaft output  
**90S/4**.....: Motor frame size  
**L05**.....: Brake type

#### KT373.01

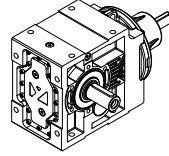

**K**.....: K series of gearbox  
**T**.....: Solid input shaft  
**3**.....: Gear unit size  
**7**.....: Revision number  
**3**.....: Stage number  
**01**.....: Solid output shaft

#### KN473.03 - A11

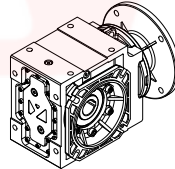

**K**.....: K series of gearbox  
**N**.....: IEC B5 flange without motor input  
**4**.....: Gear unit size  
**7**.....: Revision number  
**3**.....: Stage number  
**03**.....: Flanged hollow shaft output  
**A11**.....: Motor type 112, B5 flange

#### KV573.0S-100L/4

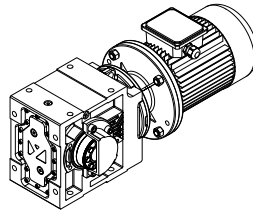

**K**.....: K series of gearbox  
**V**.....: Motor input with B5/B14 flanged  
**5**.....: Gear unit size  
**7**.....: Revision number  
**3**.....: Stage number  
**0S**.....: Hollow shaft output with shrink disk  
**100L/4**.....: Motor size and number of poles

#### Typenbezeichnungsbeispiele

##### KR273.00-90S/4-L05

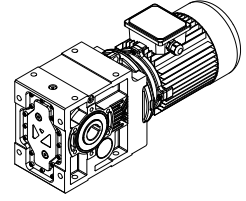

**K**.....: K Serie Getriebe  
**R**.....: Motorverbindung  
**2**.....: Größe von Gehäuse  
**7**.....: Änderungsnummer  
**3**.....: Stufenanzahl (2 stufig)  
**00**.....: Hohlausgangswelle  
**90S/4**.....: Motorbaugröße  
**L05**.....: Bremse

#### KT373.01

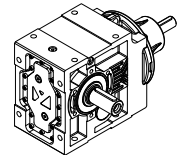

**K**.....: K Serie Getriebe  
**T**.....: Vollwelleneingang ohne Motor  
**3**.....: Größe der Gehäuse  
**7**.....: Änderungsnummer  
**3**.....: Stufenanzahl  
**01**.....: Vollwelle

#### KN473.03 - A11

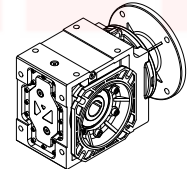

**K**.....: K Serie Getriebe  
**N**.....: IEC B5 Flansch ohne Motor  
**4**.....: Größe von Gehäuse  
**7**.....: Änderungsnummer  
**3**.....: Stufenanzahl  
**03**.....: Hohlwelle mit Flanschverbindung  
**A11**.....: Motortyp 112, B5 Motorflansch

#### KV573.0S-100L/4

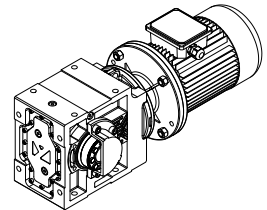

**K**.....: K Serie Getriebe  
**V**.....: Mit Motor und IEC B5/B14 Flansch  
**5**.....: Größe von Gehäuse  
**7**.....: Änderungsnummer  
**3**.....: Stufenanzahl  
**0S**.....: Hohlwelle mit Schrumpfscheibe  
**100L/4**.....: Motorbaugröße und Anzahl der Pole



# Genel Bilgiler

## General Information

### Einführung

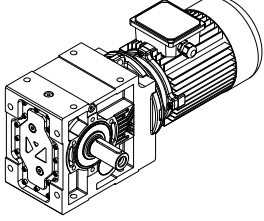
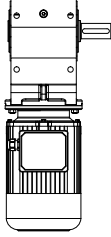
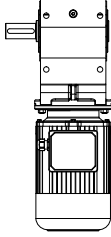
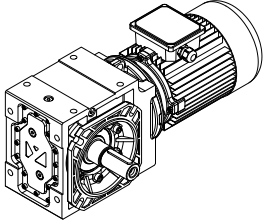
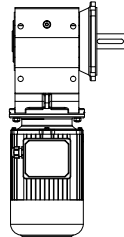
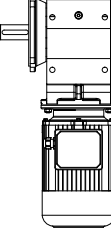
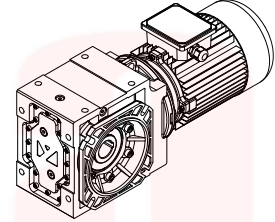
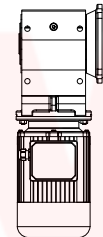
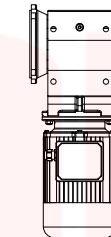
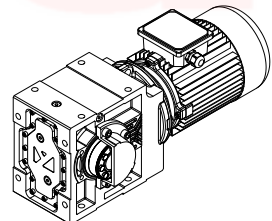
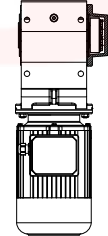
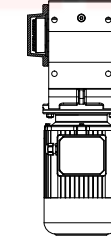
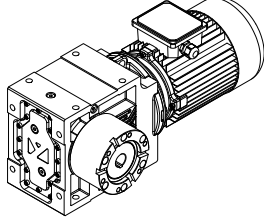
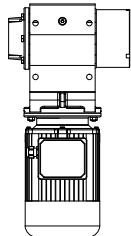
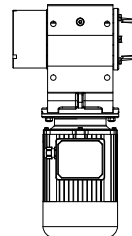

Redüktör Çıkış Özelliği Gearbox Output Specification Eigenschaft der Ausgang	R	L
 K..01		
 K..02		
 K..03		
 K..0S		
 K..0E		



# Genel Bilgiler

## General Information

### Einführung



#### Klemens Pozisyonları

Aşağıda gösterildiği gibi klemens kutuları farklı açılarda olabilir (A..G). Doğru pozisyon için ilgili ölçü sayfasını dikkate alınız

#### Terminal Box Positions

Terminal Boxes can be at different angular positions (A to G) as shown below. Please take in to account related gearbox dimensions on pages for right position.

#### Klemmenkastenpositionen

Klemmenkasten können unterschiedliche Stellungen nehmen, siehe unten. (A bis G) Bitte beachten die Abmessungsseiten Sie für die richtige Position.

A

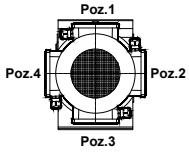

B

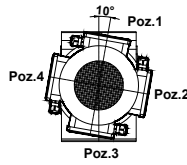

C

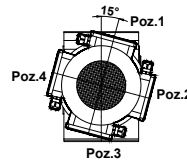

D

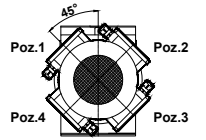

E

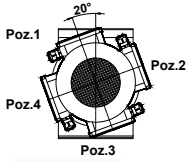

F

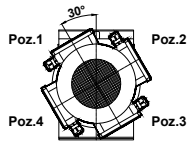

G

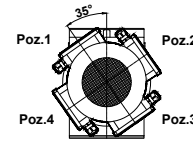

#### Klemens Kablo Çıkış Pozisyonları

Kablo çıkış pozisyonları motor üstünden bakarak sağ veya sol olarak aşağıdaki gibi seçilebilir.

#### Terminal Box Cable Output Positions

Terminal box cable output positions can be selected as right side or left side according to top view of terminal box.

#### Kabelausgang von der Klemmenkasten

Kabelausgangsseite von der Klemmenkasten kann als links oder rechts gemäß Blickrichtung oben von dem Motor ausgewählt werden.

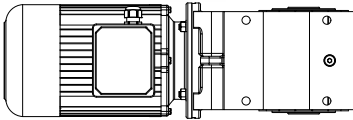

A tipi kablo çıkışı / B type Cable Output / Kabelausgang A

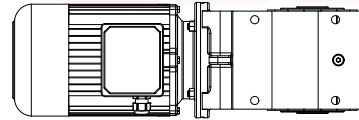

B tipi Kablo Çıkışı / B type Cable output / Kabelausgang B

#### Moment kolu Pozisyonları

Moment kolu pozisyonları aşağıdaki gibidir.

#### Torque Arm Positions

Torque arm positions are shown on below.

#### Stelle Von Drehmomentstütze

Drehmomentstützestellungen wurden unten dargestellt.

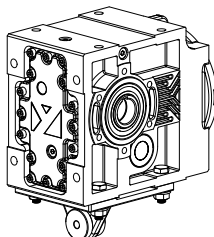

Std

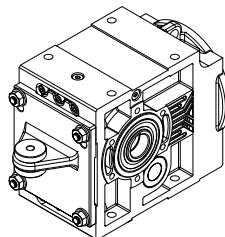

T1

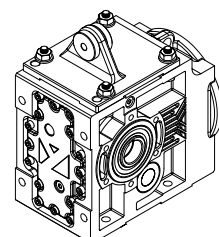

T2



# Genel Bilgiler

## General Information

### Einführung



#### Motor Büyüklüğüne Göre Geometrik Mümkün Çevrim Oranları

Geometrically Possible Combinations of Ratios According to Motor Size

Geometrisch mögliche Kombinationen von Übersetzungen nach Motorbaugröße

#### Motor Büyüklüğü / Motor Size / Motorbaugröße

Tip Type	Kademe Stages	63	71	80	90	100	112	132
KR273..	3	6,94-113,65	6,94-113,65	6,94-96,68	6,94-83,48	6,94-72,92	6,94-50,51	-
KR275..	5	54,40-719,79	54,40-719,79	54,40-719,79	54,40-719,79	-	-	-
KR276..	6	735,5-1759,48	735,5-1759,48	735,42-1759,48	735,42-1759,48	-	-	-
KR373..	3	-	7,73-9,97 14,44-21,90 33,65-148,75	7,73-9,97 14,44-21,90 33,65-127,30	7,73-9,97 14,44-21,90 33,65-110,61	5,68-97,26	5,68-68,65	5,68-51,05
KR374..	4	127,14-367,43	127,14-367,43	127,14-367,43	127,14-367,43	-	-	-
KR375..	5	312,5-1094,97	312,5-1094,97	312,5-1094,97	312,5-1094,97	-	-	-
KR376..	6	853,34-3467,39	853,34-3467,39	853,34-3467,39	853,34-3467,39	-	-	-
KR473..	3	-	-	23,76-30,11 60,63-153,47	23,76-30,11 60,63-153,47	9,06-110,95	6,21-97,79	6,21-76,83
KR474..	4	-	160,79-472,63	160,79-472,63	160,79-472,63	160,75-207,41	160,79-181,88	-
KR475..	5	509,34-1767,9	509,34-1767,9	509,34-1767,9	509,34-1767,9	509,34-1142,99	509,34-971,77	-
KR476..	6	2183,54-5226,85	2183,54-5226,85	2183,54-5226,85	2183,54-5226,85	2183,54-3602,83	2183,54-3379,28	-
KR573..	3	-	-	-	-	20,24-25,78 52,88-125,51	20,24-25,78 38,16-109,86	6,91-97,19
KR574..	4	-	117,96-469,74	117,96-469,74	117,96-469,74	117,96-328,56	117,96-158,64 246,42	117,96
KR575..	5	507,09-2236,28	507,09-2236,28	507,09-2236,28	507,09-2236,28	-	-	-
KR576..	6	2328,84-6611,61	2328,84-6611,61	2328,84-6611,61	2328,84-6611,61	-	-	-
KR673..	3	-	-	-	-	80,38-128,24	80,38-128,24	9,45-14,49 21,32-32,68 44,65-128,24
KR674..	4	-	-	82,25-363,81	82,25-363,81	82,25-363,81	82,25-321,51	82,25-123,38
KR675..	5	-	531,08-1875,03	531,08-1875,03	531,08-1875,03	423,9-1875,03	423,9-809,27	423,9-724,08
KR676..	6	-	1884,33-12680,66	1884,33-12680,66	1884,33-12680,66	1884,33-5445,72	1884,33-3844,04	1884,33-2858,39
KR773..	3	-	-	-	-	-	-	12,89 26,52 51,13-111,63
KR774..	4	-	-	127,11-396,00	127,11-396,00	127,11-139,00	127,11-139,00	127,11-311,14
KR775..	5	-	547,17-3203,12	547,17-3203,12	547,17-3203,12	436,74-2066,04	436,74-833,78	436,74-655,11
KR776..	6	-	1941,39-15618,73	1941,39-15618,73	1941,39-15618,73	1941,39-5610,63	1941,39-3960,44	1941,39-2944,95
KR873..	3	-	-	-	-	-	-	55,53-115,87
KR874..	4	287,1-438,7	287,1-438,7	287,1-438,7	287,1-438,7	86,63-438,70	86,63-383,99	86,63-339,7
KR875..	5	463,83-1891,08	463,83-1891,08	463,83-1891,08	463,83-1891,08	463,83-1891,08	463,83-1671,18	463,83-1313,07
KR876..	6	2074,42-12789,19	2074,42-12789,19	2074,42-12789,19	2074,42-12789,19	2074,42-11245,67	2074,42-7938,12	2074,42-5902,70





# Genel Bilgiler

## General Information

### Einführung



#### Motor Büyüklüğüne Göre Geometrik Mümkün Çevrim Oranları

Geometrically Possible Combinations of Ratios According to Motor Size  
Geometrisch mögliche Kombinationen von Übersetzungen nach Motorbaugröße

#### Motor Büyüklüğü / Motor Size / Motorbaugröße

Tip Type Typ	Kademe Stages Stufen	160	180	200	225	250	280
KR273..	3	-	-	-	-	-	-
KR275..	5	-	-	-	-	-	-
KR276..	6	-	-	-	-	-	-
KR373..	3	-	-	-	-	-	-
KR374..	4	-	-	-	-	-	-
KR375..	5	-	-	-	-	-	-
KR376..	6	-	-	-	-	-	-
KR473..	3	6,21-23,19 39,11-59,19	6,21-20,07 39,11-51,22	-	-	-	-
KR474..	4	-	-	-	-	-	-
KR475..	5	-	-	-	-	-	-
KR476..	6	-	-	-	-	-	-
KR573..	3	6,91-67,37	6,91-67,37	6,91-18,80 30,25-35,34	-	-	-
KR574..	4	-	-	-	-	-	-
KR575..	5	-	-	-	-	-	-
KR576..	6	-	-	-	-	-	-
KR673..	3	8,31-100,90	8,31-90,21	8,31-68,47	8,31-68,47	-	-
KR674..	4	-	-	-	-	-	-
KR675..	5	423,9-489,82	423,9	-	-	-	-
KR676..	6	-	-	-	-	-	-
KR773..	3	7,41-111,63	7,41-99,00	7,41-76,59	7,41-51,13	7,41-51,13	-
KR774..	4	-	-	-	-	-	-
KR775..	5	-	-	-	-	-	-
KR776..	6	-	-	-	-	-	-
KR873..	3	49,75-115,87	11,05-13,93 19,26-24,28 34,28-103,24	9,63-81,06	9,63-55,53	9,63-55,53	9,63-55,53
KR874..	4	86,63-235,47	86,63-235,47	-	-	-	-
KR875..	5	-	-	-	-	-	-
KR876..	6	-	-	-	-	-	-



# Genel Bilgiler

## General Information

### Einführung



#### Servis Faktörü

Servis faktörü (fs) redüktörün çalıştığı şartlar ile uyumlu olması için gerekli olan emniyet katsayısıdır. "fs =1" Düzgün ve sakin yüklerde, günlük sekiz saat ve saatte yüz start çalışmayı karşılar.

Aşağıdaki etkenlere bağlıdır:

- Günlük çalışma süresi
- Yük sınıfı
- Bir saatteki start sayısı
- Redüktör tahrik tipi
- Diğer gözlemler

Bu etkenleri göz önüne aldığımızda, gerekli servis faktörünü belirlemek için:

1. Makinanın günlük çalışma süresini tespit ediniz.
2. Makinanın ne türde yükler verdiğini tespit ediniz (Sayfa 19-20).

- U - Düzgün ve sabit yükler
- M - Orta darbeli yükler
- H - Ağır darbeli yükler

Yük sınıfının daha teknik seçimi için rotora indirgenmiş toplam atalet momenti formülünden faydalanabilirsiniz (Sayfa 20).

3. Saatteki start sayısını tespit ediniz.
4. İlk üç maddeye bağlı servis faktörünü aşağıdaki tablodan seçiniz.

5. fs Redüktörümüzün tahrik tipine bağlı olarak "k" katsayısı ile çarpılarak artırılır.

- k=1 :Elektrik motoru veya hidromotor  
k=1.25 :İçten yanmalı çok silindirli motor  
k=1.5 :İçten yanmalı tek silindirli motor

#### Service Factor

Service Factor (fs) is a safety coefficient, which takes into account the different running conditions of the driven machine. "fs=1" is used for uniform loads 8 hours working per day and up to 100 starts per hour.

Service factor depends on:

- Running time
- Nature of load
- Frequency of starting
- Driver type
- Other considerations

For the right selection of the needed service factor for your machine;

1. Determine the running time of driven machine.
2. Select the nature of load of driven machine (Page 19-20).

- U - Uniform loads
- M - Moderate loads
- H - Heavy shock loads

For a better selection, the nature of load can be calculated from the formulas given (page 20).

3. Determine frequency of starting.
4. After determining the above mentioned factors, the service factor can be easily selected from the table given below.
5. The selected service factor multiplied with the factor "k" according to the driver type;

- k=1 :Electric motor or Hydrolicmotor  
k=1.25 :Multicylinder internal combustion engine  
k=1.5 :Single cylinder internal combustion engine

#### Betriebsfaktor

Der Betriebsfaktor (fs) ist ein Sicherheitsfaktor für die Getriebe, damit sie unter den Betriebsbedingungen sicher arbeiten. "fs =1" steht für gleichförmige Belastung, 8 Stunden pro Tag und bis zu 100 Schaltungen pro Stunde.

Betriebsfaktor ist abhängig von:

- Betriebsdauer
- Belastungsart
- Schalthäufigkeit
- Antriebsart
- Andere Faktoren

Um die richtigen Betriebsfaktor festzulegen;

1. Betriebsdauer der angetriebenen Maschine bestimmen.
2. Belastungsart der angetriebenen Maschine auswählen.

- U - Gleichförmige Belastung
- M - Ungleichförmige Belastung
- H - Stark Ungleichförmige Belastung

Um eine bessere Auswahl zu treffen, können die Belastungsarten mit den angegebenen Formeln (Seite 20) errechnet werden.

3. Schalthäufigkeit bestimmen.
4. Nach Bestimmen der oben angegebenen Werte, können die Betriebsfaktoren von der unten stehenden Tabelle entnommen werden.
5. Der ausgewählte Betriebsfaktor muß mit dem Faktor "k" abhängig von der Antriebsart multipliziert werden

- k=1 :Elektromotor oder Hydraulikmotor  
k=1.25 :Vielzylindermotor  
k=1.5 :Einzyldermotor

Günlük Çalışma Süresi  
Operating Time hour / Day  
Laufzeit Std. / Tag

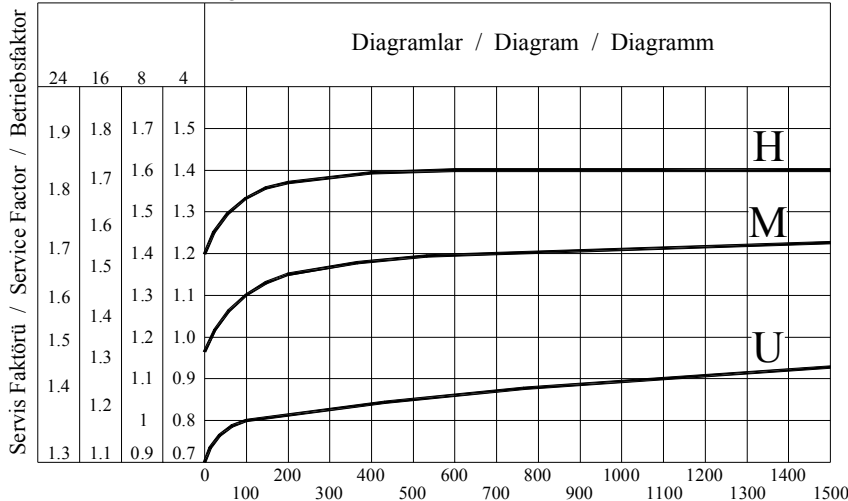

Start sayısı / Saat  
Cycle / Hour  
Schaltungen / Std.



# Genel Bilgiler

## General Information

### Einführung



#### Yük Sınıflandırması

##### Krenler:

- U - Kaldırma Dişlileri
- Palanga Dişlileri
- M - Bomlu Vinç Dişlileri
- Yana Döndürme Dişlileri
- H - Yürütme Dişlileri

##### Pompalar:

- U - Santrifuj Pompalar (ince sıvı)
- M - Santrifuj Pompalar (yarı sıvı)
- H - Basınçlı Pompalar
- Dalgiç Pompalar

##### Taş ve Kil İşleme Makinaları:

- H - Çekiçli Değirmenler
- Döner Fırınlr
- Dövücü Değirmenler
- Kırıcılar
- Küreli Değirmenler
- Tuğla Presi
- Tüp Değirmenler

##### Tekstil Makinaları:

- M - Basma ve Boyama Makinaları
- Dokuma Tezgahları
- Hallac Makinaları
- Harman Makinaları
- Taneleme (Debegat )Tekneleri

##### Yağ Sanayi:

- M - Besleme Pompaları
- Döner Delme Teçizatları

##### Yiyecek Sanayi:

- M - Kutu Bıçaklar
- Kutu Kaplama
- Mayalama Tekneleri
- H - Kenar Açma

##### Çamaşır Yıkama Makinaları:

- M - Döner Kurutucular
- Yıkama Makinaları

##### Hadde Makinaları:

- M - Hız Ayarlı Silindirler
- Sabit Silindirler
- Sarma Makaraları
- Tel Çekme
- H - Çubuk Kesme Makinaları
- Döner Tablalar (büyük)
- Kabuk Sıyırma Makinaları
- Plaka Haddelme
- Silindir Haddelme
- Soğuk Haddelme

#### Load Classification

##### Cranes:

- U - Hoist Gears
- Lifting Gears
- M - Defrocking jib Gears
- Slowing Gears
- H - Travelling Gears

##### Pumps:

- U - Centrifugal Pumps (light liquids)
- M - Centrifugal Pumps (semi liquid)
- H - Pressure Pumps
- Plunger Pumps

##### Stone and Clay Working Machines:

- H - Hammer Mills
- Rotary Kilns
- Beater Mills
- Breakers
- Ball Mills
- Brick Presses
- Tup Mills

##### Textile Machines:

- M - Printing and Dyeing Machines
- Looms
- Willow
- Batchers
- Tanning Vats

##### Oil Industry:

- M - Pipeline Pumps
- Rotary Drilling Equipment

##### Food Industry:

- M - Cane Knives
- Cane Crushers
- Mach Tubs
- H - Cane Mills

##### Laundries:

- M - Tumblers
- Washing Machines

##### Metal Rolling Mills:

- M - Roller Adjustment Drives
- Roller Straightened
- Winding Machines
- Wire Drawing Benches
- H - Billet Shears
- Rotary Tables (heavy)
- Descaling Machines,
- Sheet Mills
- Manipulators
- Cold Rolling Mills

#### Belastungsart

##### Krananlagen:

- U - Einziehwerke
- Hubwerke
- M - Schwenkwerke
- Wippwerke
- H - Fahrwerke

##### Pumpen:

- U - Kreiselpumpen (leichte Flüssigkeit)
- M - Kreiselpumpen (zahe Flüssigkeit)
- H - Prebpumpen
- Plungerpumpen

##### Stein- und Erdebearbeitende Maschine

- H - Hammermühlen
- Drehofen
- Schlagmühlen
- Brecher
- Kugelmühlen
- Ziegelpressen
- Rohrmühlen

##### Textilmaschinen:

- M - Drukerei
- Farbereimachinen
- Aufwickler
- Webstuhle
- Gerbfasser
- Reibwolfe

##### Erdölgewinnung:

- M - Pipeline Pumpen
- Rotative Bohranlagen

##### Nahrungsmittelmachinen:

- M - Rohrschneiden
- Knetmaschinen
- Maichen
- H - Rohrmühlen

##### Waschereimaschinen:

- M - Trommeltrockner
- Waschmaschinen

##### Wälzwerke:

- M - Rollenrichtmaschinen
- Walzenantriebe
- Drahtzuge
- Haspeln
- H - Blechscheren
- Rollgänge (schwer)
- Knüppelscheren
- Schöpfscheren
- Stranggubanlagen
- Kaltwälzwerke



# Genel Bilgiler

## General Information

### Einführung



#### İnşaat Makinaları:

- M - Beton Mikserleri  
- Ağır Yük Asansörleri

#### Kağıt Makinaları:

- H - Islak Presler  
- Kağıt Hamur Makinaları  
- Kurutma Silindirleri  
- Perdahlama Silindirleri

#### Kauçuk Makinaları:

- M - Kalenderler  
- Mikserler  
H - Extruderler  
- Hamur Karma  
- Silindirler

#### Kimya Sanayi:

- M - Agidatörler (yarı sıvı)  
- Kurutma Merdaneleri  
- Mikserler ve Silindirleri

#### Konveyörler:

- M - Bant Ceppli Konveyörler  
- Çelik Bantlı Konveyörler  
- Dökme Yüklü Kayışlı Konv.  
H - Yük Asansörleri  
- Parça Yüklü Kayışlı Konv.

#### Building Machines:

- M - Concrete Mixers  
- Hoist

#### Paper Machines:

- H - Wet Presses  
- Pulpers  
- Drying Cylinders  
- Glazing Cylinders

#### Rubber Machinery:

- M - Calenders  
- Mixers  
H - Extruders  
- Pug Mills  
- Rolling Mills

#### Chemical Ind.:

- M - Aggidators (semi- liquid)  
- Drying Drums.  
- Mixers and Rolling Mills

#### Conveyors:

- M - Band Pocket Conveyors  
- Steel Belt Conveyors  
- Belt Conveyors  
H - Hoists  
- Bulk Belt Conveyors

#### Baumaschinen:

- M - Betonmischermaschinen  
- Bauaufzüge

#### Papiermaschinen:

- H - Naßpressen  
- Gautschen  
- Trockenzyylinder  
- Glattzyylinder

#### Kunststoffmaschinen:

- M - Kalender  
- Mischer  
H - Extruder  
- Knetwerke  
- Wälzwerke

#### Chemische Industrie:

- M - Rührwerke (leichte Flüssig.)  
- Trockentrommeln  
- Mischer und Wälzwerke

#### Förderanlagen:

- M - Gurtaschenbecherwerke  
- Stahlbandförderer  
- Gurtbandförderer (Schüttgut)  
H - Schrägaufzüge  
- Gurtbandförderer (Stückgut)

U	<b>Uniform Yük</b> Uniform Loads Gleichförmige Last	$F_i < 0,25$
M	<b>Orta Darbeli Yük</b> Moderate Loads Ungleichförmige Last	$F_i < 3$
H	<b>Darbeli Yük</b> Heavy Shock Loads Stark Ungleichförmige Last	$F_i < 10$

$$J'_{ext} = \frac{J_{ext}}{i^2}$$

$$F_i = \frac{J'_{ext}}{J_{rotor}}$$

$J'_{ext}$  : **Motor miline indirgenmiş toplam dış atalet momenti**  
External moments of inertia reduced to the motor shaft  
Externe Massenträgheitsmomente reduziert auf Motorwelle

$i$  : **Tahvil oranı**  
Transmission ratio  
Übersetzung

$J_{rotor}$  : **Motorun atalet momenti**  
Moments of inertia to the motor  
Massenträgheitsmoment



# Genel Bilgiler

## General Information

### Einführung



#### Redüktör Dönüş Yönleri

K Serisi ürünlerimiz için kullanılan yön tanımlaması aşağıdaki gibidir. Aşağıdaki tanımlama kilitli redüktörler için de geçerlidir.

#### Direction of Rotation

K Series direction of rotation of Yilmaz products are defined as follows. The definitions are also valid for gear units with backstop.

#### Getriebedrehrichtungen

Die Drehrichtungen für K Serie Getriebe sind wie folgt definiert. Die Definition ist auch bei Getrieben mit Rücklaufsperrung gültig.

	3-5 Kademe / 3-5 Stages / 3-5 Stufig	4-6 Kademe / 4-6 Stages / 4-6 Stufig
<b>Saat Yönünde</b> Clockwise Rechtslauf <b>CW</b>		
<b>Saat Tersi Yönünde</b> Counter Clockwise Linkslauf <b>CCW</b>		

Giriş mili dönüş yönüne göre çıkış mili dönüş yönleri aşağıdaki gibidir.

Output shaft rotation directions according to the input shaft rotation directions are as follows.

Drehrichtungen der Abtriebswelle im Abhängigkeit von der Antriebswellen sind wie folgendes;

3-5 kademe / 3-5 Stages / 3-5 Stufig	4-6 Kademe / 4-6 Stages / 4-6 Stufig



# Genel Bilgiler

## General Information

### Einführung



### Radyal Yükler

Çıkış miline gelebilecek radyal yükler yatak ömrüne göre belirlenmiş ve tablo halinde verilmiştir. Bu tabloda verilen  $F_{qam}$  güvenilir radyal yükü  $f_s=1$  şartı ve yükün mil ortasını yüklediği durum için verilmiştir. Darbeli yüklerin olması durumunda daha önce verilmiş olan servis faktörü tablosundaki değerler dikkate alınmalıdır. Güvenilir aksiyal yük ( $F_{ama}$  veya  $F_{ame}$ ) verilen güvenilir radyal yükün ( $F_{qam}$  veya  $F_{qem}$ ) %25'i kadar alınır. Verilen radyal ve eksenel yükler kuvvetin en kötü açı şartında etki ettiği durum için verilmiştir. Mil ortasına gelen kuvvetin açısına göre daha yüksek radyal yükler mümkündür (Firmamıza danışınız). Bağlantı şekline göre oluşan radyal yük  $F_q$  sayfa 23 de verilen formüller yardımı ile hesaplanır. Redüktör seçiminde ;

$$\begin{aligned} F_{qa} &\leq F_{qam} \\ F_{qe} &\leq F_{qem} \end{aligned}$$

şartı göz önünde tutulmalı. Eğer etkiyen radyal kuvvet milin orta noktasında değil ise verilen güvenilir değerler aşağıda verilen formül ile düzeltilmesi gerekir.

$$F_{qam}' = F_{qam} \times \frac{t}{y+u}$$

$$F_{qem}' = F_{qem} \times \frac{t}{y+u}$$

"t", "y" Değerleri aşağıda verilmiştir. "u" Değeri görüldüğü gibi kuvvetin uygulama noktasıdır.

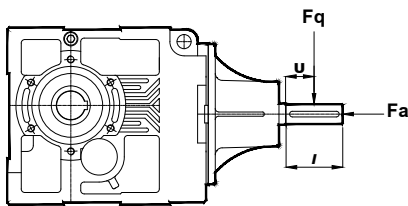
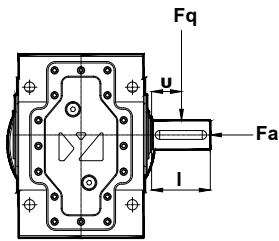

### Overhung Loads

The permissible overhung loads are calculated by considering working life and is listed on the tables. The given permissible overhung loads  $F_{qam}$  are based on  $f_s=1$  and are valid for forces which are applied to the midpoint of the shaft. For shock loading applications the service factor given on the table must take into consideration. The permissible axial load ( $F_{ama}$  or  $F_{ame}$ ) is %25 x ( $F_{qam}$  or  $F_{qem}$ ). The listed permissible overhung loads are based on the worst loading direction. Higher overhung loads can be applied for different loading directions (Please ask if requested). The effective overhung load at the gear box shaft  $F_q$  will be determined with the given formulas on page 23. In Selection ;

$$\begin{aligned} F_{qa} &\leq F_{qam} \\ F_{qe} &\leq F_{qem} \end{aligned}$$

these formulas must be taken into consideration. If the load is not applied at the midpoint of the shaft; the given permissible load must be corrected with the following formulas.

$$F_{qam}' = F_{qam} \times \frac{t}{y+u}$$

$$F_{qem}' = F_{qem} \times \frac{t}{y+u}$$

The values "t", "y" can be taken from the below table. The value "u" is the length of the application point as shown below.

### Querkräfte

Die in den nachfolgenden Tabellen angegebenen zulässigen Radialbelastungen  $F_{qam}$  gelten bei Kraftangriff auf die Mitte Wellenendes. Den Angaben liegt der Betriebsfaktor  $f_s=1$  zu Grunde. Bei stoßartigen Belastungsfällen ist auch hier der entsprechende Betriebsfaktor zu berücksichtigen. Zulässige Axialkräfte  $F_{ama}$  oder  $F_{ame}$  können ohne weitere Nachrechnung bis zu einer Höhe von ca. 25% der zulässigen Radialbelastung  $F_{qam}$  oder  $F_{qem}$  aufgenommen werden. Bei der Ermittlung der zulässige Querkräfte sind höhere Werte möglich (Bitte Rückfragen). Die auftretende Querkräfte  $F_q$  ab der Getriebewelle wird wie in der nachfolgenden Formel bestimmt.

Bei dieser Auswahl;

$$\begin{aligned} F_{qa} &\leq F_{qam} \\ F_{qe} &\leq F_{qem} \end{aligned}$$

müssen die oben angegebenen Bedingungen berücksichtigt werden. Ist der Kraftangriff nicht auf Wellenmitte, so kann die zulässige Querkräfte mit Hilfe der unten stehenden Formel auf jede beliebige Stelle umgerechnet werden.

$$F_{qam}' = F_{qam} \times \frac{t}{y+u}$$

$$F_{qem}' = F_{qem} \times \frac{t}{y+u}$$

Die Werte "t" und "y" sind in den nachfolgenden Tabellen angegeben. Der Wert "u" ist die Stelle des Kraftangriffs wie auf der nächsten Seite angegeben.

Çıkış mili radyal kuvvet hesabı düzeltme katsayıları							
Overhung Load correcting values on output shaft							
Querkräfte auf Ausgangswelle Korrigierungszahlen							
Tip	KR..273	KR..373	KR..473	KR..573	KR..673	KR..773	KR..873
Type							
t	162	199	236	273	344	408	485
y	132	159	186	213	274	323	380
l	60	80	100	120	140	170	210

Giriş mili Radyal kuvvet hesabı düzeltme katsayıları							
Overhung load correcting values on input shaft							
Querkräfte auf Einangangswelle korrigierungszahlen							
Tip	KT..273	KT..373	KT..473	KT..573	KT..673	KT..773	KT..873
Type							
t	111	126	137	158	180	207	220
y	86	96	102	113	130	147	165
l	50	60	70	90	100	120	110



# Genel Bilgiler

## General Information

### Einführung



#### Radyal Yüklerin Hesabı

#### Calc. Of Overhung Loads

#### Berechnung der Querkräfte



Radyal Yük  $F_q$  [N]'nin hesaplanması da, gerekli tahrik momenti  $M$  [Nm], kasnak veya dişli çapı  $D$  [mm] olmak üzere aşağıdaki formüller kullanılır.

Radial Load  $F_q$  [N] is calculated with the following equations where required moment  $M$  [Nm] and hoop or gear diameter  $D$  [mm] is used.

Der Fall der radialen Belastung  $F_q$  [N] kann mit den angegebenen Gleichungen berechnet werden. Antriebsmoment  $M$  [Nm] und Zahnrad- oder Riemenscheiben Durchmesser  $D$  [mm].



#### 1. Elastik Kaplin

Çalışma sırasında oluşan sapmalar kaplinin güvenlik sınırları içinde ise kuvvetler ihmal edilebilir.

#### 1. Elastic Coupling

If Elastic Coupling is working in its reliable working area, the overhung loads can be neglected.

#### 1. Elastische Kupplung

Wenn die elastische Kupplung in ihrem zulässigen Arbeitsbereich arbeitet, können die radialen Belastungen vernachlässigt werden.



#### 2. Düz Dişli (20° kavrama açısı)

$$F_q = \frac{2100 \times M_2}{D}$$

#### 2. For Spur Gear (Pressure angle 20°)

$$F_q = \frac{2100 \times M_2}{D}$$

#### 2. Stirnradgetriebe (Angriffswinkel 20°)

$$F_q = \frac{2100 \times M_2}{D}$$



#### 3. Küçük Hızlarda Zincir Dişli ( $z > 17$ )

$$F_q = \frac{2100 \times M_2}{D}$$

#### 3. For Chain Drive With Low Speed ( $z > 17$ )

$$F_q = \frac{2100 \times M_2}{D}$$

#### 3. Kettenantrieb mit niedriger Geschwindigkeit ( $z > 17$ )

$$F_q = \frac{2100 \times M_2}{D}$$



#### 4. Triger Kayış

$$F_q = \frac{2500 \times M_2}{D}$$

#### 4. For Triger Belt

$$F_q = \frac{2500 \times M_2}{D}$$

#### 4. Zahnriemenantrieb

$$F_q = \frac{2500 \times M_2}{D}$$



#### 5. V Kayış

$$F_q = \frac{5000 \times M_2}{D}$$

#### 5. For V Belt

$$F_q = \frac{5000 \times M_2}{D}$$

#### 5. Keilriemenantrieb

$$F_q = \frac{5000 \times M_2}{D}$$



#### 6. Gerdirme Makaralı Kayış

$$F_q = \frac{5000 \times M_2}{D}$$

#### 6. Flat Belt With Spanning Pulley

$$F_q = \frac{5000 \times M_2}{D}$$

#### 6. Flachriemenantrieb mit Spannungstrommel

$$F_q = \frac{5000 \times M_2}{D}$$



# Genel Bilgiler

## General Information

### Einführung



### Ekstruder Tiplerde Müsade Edilebilir Eksenal Yükler

Permissible Axial Loads for Extruder Types  
Zulässige Axialkräfte für Extruder Typ Getriebe

KRE273					
n <sub>2</sub>	F <sub>ama</sub> [kN]				
	Ömür / Lifetime / Lebensdauer Lh [saat] / [hour] / [Stunde]				
	40000	20000	10000	5000	
20	27.0	33.3	41.0	50.5	
30	23.9	29.5	36.3	44.7	
40	22.0	27.0	33.3	41.0	
50	20.5	25.3	31.1	38.4	
65	19.0	23.4	28.8	35.5	
80	17.8	22.0	27.0	33.3	
100	16.7	20.5	25.3	31.1	
120	15.8	19.4	23.9	29.5	
140	15.1	18.6	22.9	28.2	
160	14.5	17.8	22.0	27.0	
180	14.0	17.2	21.2	26.1	
200	13.5	16.7	20.5	25.3	
220	13.2	16.2	20.0	24.6	
240	12.8	15.8	19.4	23.9	
260	12.5	15.4	19.0	23.4	
280	12.2	15.1	18.6	22.9	
300	12.0	14.8	18.2	22.4	
320	11.8	14.5	17.8	22.0	

n<sub>2</sub> : Çıkış Devri [d/dak]  
Output Speed [rpm]  
Abtriebsdrehzahl [U/min]

KRE373					
n <sub>2</sub>	F <sub>ama</sub> [kN]				
	Ömür / Lifetime / Lebensdauer Lh [saat] / [hour] / [Stunde]				
	40000	20000	10000	5000	
20	104.8	129.0	158.8	195.6	
30	92.7	114.2	140.6	173.2	
40	85.1	104.8	129.0	158.8	
50	79.6	98.0	120.6	148.5	
65	73.5	90.5	111.5	137.3	
80	69.1	85.1	104.8	129.0	
100	64.6	79.6	98.0	120.6	
120	61.2	75.3	92.7	114.2	
140	58.4	71.9	88.5	109.0	
160	56.1	69.1	85.1	104.8	
180	54.2	66.7	82.1	101.1	
200	52.5	64.6	79.6	98.0	
220	51.0	62.8	77.3	95.2	
240	49.7	61.2	75.3	92.7	
260	48.5	59.7	73.5	90.5	
280	47.4	58.4	71.9	88.5	
300	46.5	57.2	70.4	86.7	
320	45.6	56.1	69.1	85.1	

n<sub>2</sub> : Çıkış Devri [d/dak]  
Output Speed [rpm]  
Abtriebsdrehzahl [U/min]

KRE473					
n <sub>2</sub>	F <sub>ama</sub> [kN]				
	Ömür / Lifetime / Lebensdauer Lh [saat] / [hour] / [Stunde]				
	40000	20000	10000	5000	
20	134.5	165.6	203.9	251.1	
30	119.0	146.6	180.5	222.3	
40	109.2	134.5	165.6	203.9	
50	102.1	125.7	154.8	190.7	
65	94.4	116.2	143.1	176.2	
80	88.7	109.2	134.5	165.6	
100	82.9	102.1	125.7	154.8	
120	78.5	96.7	119.0	146.6	
140	75.0	92.3	113.7	140.0	
160	72.0	88.7	109.2	134.5	
180	69.5	85.6	105.4	129.8	
200	67.3	82.9	102.1	125.7	
220	65.4	80.6	99.2	122.2	
240	63.8	78.5	96.7	119.0	
260	62.2	76.6	94.4	116.2	
280	60.9	75.0	92.3	113.7	
300	59.6	73.4	90.4	111.3	
320	58.5	72.0	88.7	109.2	

n<sub>2</sub> : Çıkış Devri [d/dak]  
Output Speed [rpm]  
Abtriebsdrehzahl [U/min]

KRE573					
n <sub>2</sub>	F <sub>ama</sub> [kN]				
	Ömür / Lifetime / Lebensdauer Lh [saat] / [hour] / [Stunde]				
	40000	20000	10000	5000	
20	172.0	211.8	260.8	779.6	
30	152.3	187.5	230.9	715.9	
40	139.7	172.0	211.8	673.9	
50	130.6	160.8	198.1	643.1	
65	120.7	148.7	183.0	608.6	
80	113.4	139.7	172.0	582.6	
100	106.1	130.6	160.8	555.9	
120	100.4	123.7	152.3	535.0	
140	95.9	118.1	145.4	518.0	
160	92.1	113.4	139.7	503.6	
180	88.9	109.5	134.8	491.3	
200	86.1	106.1	130.6	480.6	
220	83.7	103.1	126.9	471.0	
240	81.5	100.4	123.7	462.5	
260	79.6	98.0	120.7	454.8	
280	77.9	95.9	118.1	447.8	
300	76.3	93.9	115.6	441.3	
320	74.8	92.1	113.4	435.4	

n<sub>2</sub> : Çıkış Devri [d/dak]  
Output Speed [rpm]  
Abtriebsdrehzahl [U/min]





# Genel Bilgiler

## General Information

### Einführung



### Ekstruder Tiplerde Müsade Edilebilir Eksenal Yükler

Permissible Axial Loads for Extruder Types  
Zulässige Axialkräfte für Extruder Typ Getrieben

KRE673				
n <sub>2</sub>	F <sub>ama</sub> [kN]			
	Ömür / Lifetime / Lebensdauer Lh [saat] / [hour] / [Stunde]			
	40000	20000	10000	5000
20	209.5	258.0	317.7	391.2
30	185.5	228.4	281.3	346.4
40	170.1	209.5	258.0	317.7
50	159.1	195.9	241.3	297.1
65	147.1	181.1	223.0	274.6
80	138.2	170.1	209.5	258.0
100	129.2	159.1	195.9	241.3
120	122.3	150.6	185.5	228.4
140	116.8	143.8	177.1	218.1
160	112.2	138.2	170.1	209.5
180	108.3	133.4	164.2	202.2
200	104.9	129.2	159.1	195.9
220	102.0	125.6	154.6	190.4
240	99.3	122.3	150.6	185.5
260	97.0	119.4	147.1	181.1
280	94.8	116.8	143.8	177.1
300	92.9	114.4	140.9	173.5
320	91.1	112.2	138.2	170.1

n<sub>2</sub> : Çıkış Devri [d/dak]  
Output Speed [rpm]  
Abtriebsdrehzahl [U/min]

KR773				
n <sub>2</sub>	F <sub>ama</sub> [kN]			
	Ömür / Lifetime / Lebensdauer Lh [saat] / [hour] / [Stunde]			
	40000	20000	10000	5000
20	350.2	431.3	531.1	653.9
30	310.1	381.8	470.2	579.0
40	284.4	350.2	431.3	531.1
50	266.0	327.5	403.3	496.6
65	245.8	302.7	372.8	459.0
80	231.0	284.4	350.2	431.3
100	216.0	266.0	327.5	403.3
120	204.5	251.8	310.1	381.8
140	195.2	240.4	296.0	364.5
160	187.6	231.0	284.4	350.2
180	181.0	222.9	274.5	338.0
200	175.4	216.0	266.0	327.5
220	170.5	209.9	258.5	318.3
240	166.1	204.5	251.8	310.1
260	162.1	199.6	245.8	302.7
280	158.5	195.2	240.4	296.0
300	155.3	191.2	235.5	290.0
320	152.3	187.6	231.0	284.4

n<sub>2</sub> : Çıkış Devri [d/dak]  
Output Speed [rpm]  
Abtriebsdrehzahl [U/min]

KRE873				
n <sub>2</sub>	F <sub>ama</sub> [kN]			
	Ömür / Lifetime / Lebensdauer Lh [saat] / [hour] / [Stunde]			
	40000	20000	10000	5000
20	403.4	496.7	611.7	753.2
30	357.1	439.8	541.5	666.9
40	327.6	403.4	496.7	611.7
50	306.3	377.2	464.5	572.0
65	283.1	348.7	429.3	528.7
80	266.0	327.6	403.4	496.7
100	248.8	306.3	377.2	464.5
120	235.5	290.0	357.1	439.8
140	224.9	276.9	341.0	419.9
160	216.0	266.0	327.6	403.4
180	208.5	256.8	316.2	389.4
200	202.0	248.8	306.3	377.2
220	196.3	241.8	297.7	366.6
240	191.3	235.5	290.0	357.1
260	186.7	229.9	283.1	348.7
280	182.6	224.9	276.9	341.0
300	178.9	220.3	271.2	334.0
320	175.4	216.0	266.0	327.6

n<sub>2</sub> : Çıkış Devri [d/dak]  
Output Speed [rpm]  
Abtriebsdrehzahl [U/min]

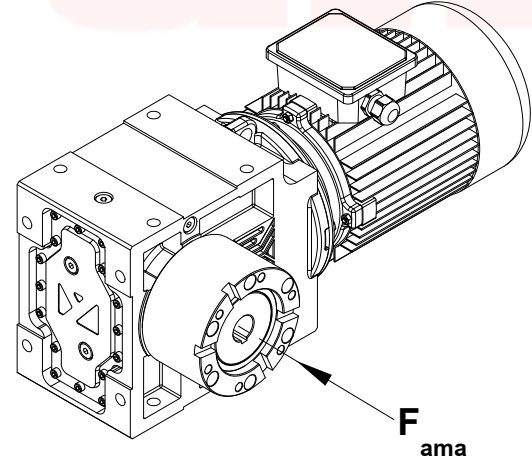



# Genel Bilgiler

## General Information

### Einführung



### Eşdeğer Güç Hesabı

Sabit devirde, ancak değişken momentlerde (güçlerde) çalışan redüktörler için eşdeğer tork altındaki, eşdeğer güç hesaplanabilir. Bu eşdeğer güç kullanılarak bilinen sabit güçteki redüktör seçim yöntemi kullanılarak seçim yapılabilir. Burada ağırlıklı torka göre eşdeğer anma torku belirlenmektedir. Hesaplanan bu güçte çalışan redüktör, teorik olarak, değişken yüklerde çalışan redüktör ile aynı emniyet değerine ve ömre sahiptir.

Bir çevrim boyunca oluşan değişken torklar, en yüksek torktan, en düşüğe doğru yatay zaman eksenini boyunca sıralanır (bakınız alttaki şekil). Bu şekile göre eşdeğer tork şu formül ile hesaplanır;

$$T_e = \left( \frac{\Delta t_1 \times T_1^{6,6} + \Delta t_2 \times T_2^{6,6} + \dots + \Delta t_n \times T_n^{6,6}}{t} \right)^{\frac{1}{6,6}}$$

Eğer  $T_n$  değerleri (en düşük tork),  $T_e$ 'nin 0,5 katının altında ise, bu tork dilimi yok sayılarak, işlem tekrarlanır;

Eğer  $T_n < T_e \times 0,5$  ise

$$T_e = \left( \frac{\Delta t_1 \times T_1^{6,6} + \Delta t_2 \times T_2^{6,6} + \dots + \Delta t_{n-1} \times T_{n-1}^{6,6}}{t - \Delta t_n} \right)^{\frac{1}{6,6}}$$

Tüm  $T_n$  değerleri  $T_e$ 'nin 0,5 katının üzerinde ise, eşdeğer güç aşağıdaki gibi hesaplanır;

$$P_{eq} = P_M = \frac{T_e \times n}{9550}$$

Eşdeğer gücün bulunmasından sonra, bu katalogta verilen redüktör seçimi bölümünde anlatılan adımlar uygulanarak redüktör seçimi tamamlanır.

### Equivalent Power Rating

*The equivalent power by an equivalent constant torque can be calculated for gearboxes working in constant speed but variable torques (or powers). Using this equivalent power it is possible to make a gearbox selection according the usual gearbox selection way with constant torques. The equivalent torque will be determined according the mean of dominating torques. The gearbox working in constant equivalent torque will theoretically have the same lifetime and safety .*

*If  $T_n$  (the lowest torque) is lower than 50% of  $T_e$ , this torque part must be taken out of the torque graph and the calculation must be repeated;*

$$T_e = \left( \frac{\Delta t_1 \times T_1^{6,6} + \Delta t_2 \times T_2^{6,6} + \dots + \Delta t_n \times T_n^{6,6}}{t} \right)^{\frac{1}{6,6}}$$

*If the  $T$  values (lowest Torque), below 0.5 times of  $T_e$ , calculations are repeated while this torque interval neglected.*

*If  $T_n < T_e \times 0,5$  then*

$$T_e = \left( \frac{\Delta t_1 \times T_1^{6,6} + \Delta t_2 \times T_2^{6,6} + \dots + \Delta t_{n-1} \times T_{n-1}^{6,6}}{t - \Delta t_n} \right)^{\frac{1}{6,6}}$$

*If all  $T_n$  values are higher then 50% of  $T_e$  then the equivalent power can be calculated by the following formula;*

$$P_{eq} = P_M = \frac{T_e \times n}{9550}$$

*After the equivalent power is determined the selection of gearbox is made according to the selection procedures given on the gearbox selection part in this catalogue.*

### Äquivalente Leistung

Die äquivalente Leistung bei äquivalenten Drehmoment kann für Getrieben mit konstanten Drehzahl und variablen Momente berechnet werden. Mit dieser Leistung kann das Getriebe ausgelegt werden, wie bei konstanten Leistung. Man bestimmt hiermit also die maßgebende Belastung. Das ausgelegte Getriebe erreicht theoretisch dem gleichen Lebensdauer und hat die gleiche Sicherheit.

Für die Berechnung der äquivalenten Drehmoment müssen die einzelnen Drehmomentanteile auf eine Zeitachse von größten bis zu kleinsten angeordnet werden (siehe unteres Bild). Das äquivalente Drehmoment wird nach folgender Formel berechnet;

$$T_e = \left( \frac{\Delta t_1 \times T_1^{6,6} + \Delta t_2 \times T_2^{6,6} + \dots + \Delta t_n \times T_n^{6,6}}{t} \right)^{\frac{1}{6,6}}$$

Wenn  $T_n$  (niedrigstes Drehmoment) kleiner als 50% von  $T_e$  ist, muss dieser Anteil vernachlässigt werden und die Berechnung soll neu durchgeführt werden;

Wenn  $T_n < T_e \times 0,5$  dann

$$T_e = \left( \frac{\Delta t_1 \times T_1^{6,6} + \Delta t_2 \times T_2^{6,6} + \dots + \Delta t_{n-1} \times T_{n-1}^{6,6}}{t - \Delta t_n} \right)^{\frac{1}{6,6}}$$

Wenn alle  $T_n$  Werte höher als 50% von  $T_e$  sind, dann wird die äquivalente Leistung nach folgender Formel berechnet;

$$P_{eq} = P_M = \frac{T_e \times n}{9550}$$

Nach Bestimmung der äquivalenter Leistung, erfolgt die Getriebeauslegung wie bei konstanter Leistung. Die Auswahlverfahren für konstante Leistung ist in diesem Katalog angegeben.

(Moment / Torque / Moment)

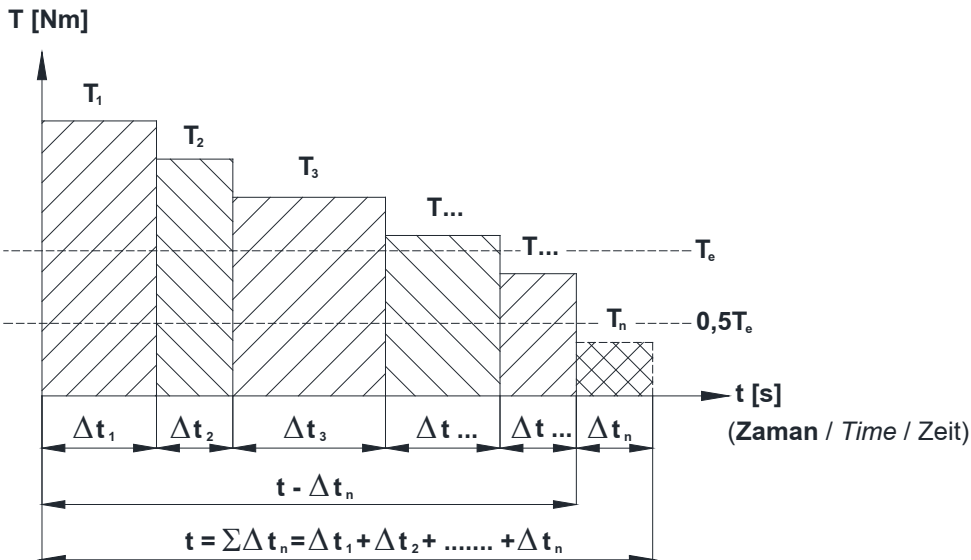



# Genel Bilgiler

## General Information

### Einführung



#### Eşdeğer Güç Hesabı Örneği

Çift yönlü çalışan ham demir haddesi için aşağıdaki çalışma koşulları belirlenmiş;

##### Veriler:

Toplam bir iş çevrimi: 2 dak.

1. Yük kademesi: 48 kNm, 30 sn
2. Yük Kademesi: 32 kNm, 22 sn
3. Yük Kademesi: 28 kNm, 15 sn
4. Yük Kademesi: 16 kNm, 10 sn
5. Yük Kademesi: 5 kNm, 43sn

Makina sabit devri: 50 d/dak

Redüktör seçimine esas olacak eşdeğer yük aranmaktadır.

##### Çözüm:

Bir çevrimin toplam zamanı;

$$t = t_1 + t_2 + t_3 + t_4 + t_5 = 120 \text{ sn}$$

Eşdeğer Tork;

$$T_e = \left( \frac{30 \times 48^{6,6} + \dots + 43 \times 5^{6,6}}{120} \right)^{\frac{1}{6,6}}$$

$$= 39,2 \text{ kNm}$$

%50 eşdeğer tork;

$$0,5 \times T_e = 19,6 \text{ kNm}$$

Her bir tork dilimi bu değer üzerinde olmalı

$$T_{4,5} < 0,5 \times T_e$$

%50 torkun altındakileri çıkararak hesabı tekrarlayalım;

$$t' = t_1 - t_4 - t_5 = 120 - 43 - 10 = 67 \text{ s}$$

$$T_e = \left( \frac{30 \times 48^{6,6} + 22 \times 32^{6,6} + 15 \times 28^{6,6}}{67} \right)^{\frac{1}{6,6}}$$

$$= 42,9 \text{ kNm}$$

Moment ve devir değerlerini kullanarak eşdeğer gücümüzü hesaplayalım;

$$P_{eq} = \frac{T_e \times n}{9550} = \frac{42,9 \times 1000 \times 50}{9550} = 225 \text{ kW}$$

Yukarıdaki güç ve devir değeri kullanılarak bu katalogta anlatılan seçim prosedürü ile redüktör seçimi yapılabilir.

#### Equivalent Power Rating Sample

The following data is given for a reversing blooming mill;

##### Torque steps:

Total one cycle time: 2 min.

- 1st torque part: 48 kNm, 30 s
- 2nd torque part: 32 kNm, 22 s
- 3th torque part: 28 kNm, 15 s
- 4th torque part: 16 kNm, 10 s
- 5th torque part: 5 kNm, 43 s

Machine constant speed: 50 rpm

The equivalent power, which is required for gear unit selection, is to determine.

##### Solution:

Total time in a cycle;

$$t = t_1 + t_2 + t_3 + t_4 + t_5 = 120 \text{ sn}$$

Equivalent Torque;

$$T_e = \left( \frac{30 \times 48^{6,6} + \dots + 43 \times 5^{6,6}}{120} \right)^{\frac{1}{6,6}}$$

$$= 39,2 \text{ kNm}$$

50% of Equivalent torque;

$$0,5 \times T_e = 19,6 \text{ kNm}$$

Every torque part must be lower then this value;

$$T_{4,5} < 0,5 \times T_e$$

We are repeating the calculation by taking out the torque parts, which are below 50%;

$$t' = t_1 - t_4 - t_5 = 120 - 43 - 10 = 67 \text{ s}$$

$$T_e = \left( \frac{30 \times 48^{6,6} + 22 \times 32^{6,6} + 15 \times 28^{6,6}}{67} \right)^{\frac{1}{6,6}}$$

$$= 42,9 \text{ kNm}$$

By using the equivalent torque and constant speed we calculate the equivalent power;

$$P_{eq} = \frac{T_e \times n}{9550} = \frac{42,9 \times 1000 \times 50}{9550} = 225 \text{ kW}$$

Now by using the above calculated equivalent power and constant speed we camake the gear-box selection with the procedures described in this catalogue.

#### Beispiel für Äquivalente Leistung

Die nachfolgenden Angaben sind für eine Blechreversierwalze;

##### Drehmoment stufen:

Gesamte Zeit für einem Arbeitszyklus: 2 min.

- Drehmomentanteil 1: 48 kNm 30 s
- Drehmomentanteil 2: 32 kNm 22 s
- Drehmomentanteil 3: 28 kNm 15 s
- Drehmomentanteil 4: 16 kNm 10 s
- Drehmomentanteil 5: 5 kNm 43 s

Maschine hat konstante Drehzahl: 50 U/min

Gesucht ist die äquivalente Leistung, die für die Getriebeauslegung nötig ist.

##### Lösung:

Gesamte Zeit für einem Arbeitszyklus;

$$t = t_1 + t_2 + t_3 + t_4 + t_5 = 120 \text{ sn}$$

Äquivalentes Drehmoment;

$$T_e = \left( \frac{30 \times 48^{6,6} + \dots + 43 \times 5^{6,6}}{120} \right)^{\frac{1}{6,6}}$$

$$= 39,2 \text{ kNm}$$

50% von äquivalenten Drehmoment;

$$0,5 \times T_e = 19,6 \text{ kNm}$$

Drehmomentanteile müssen größer als dieser Wert sein;

$$T_{4,5} < 0,5 \times T_e$$

Wir wiederholen die Berechnung nochmals ohne die kleine Drehmomentanteile;

$$t' = t_1 - t_4 - t_5 = 120 - 43 - 10 = 67 \text{ s}$$

$$T_e = \left( \frac{30 \times 48^{6,6} + 22 \times 32^{6,6} + 15 \times 28^{6,6}}{67} \right)^{\frac{1}{6,6}}$$

$$= 42,9 \text{ kNm}$$

Mit Hilfe von äquivalenten Drehmoment und konstanter Drehzahl berechnet man die äquivalente Leistung;

$$P_{eq} = \frac{T_e \times n}{9550} = \frac{42,9 \times 1000 \times 50}{9550} = 225 \text{ kW}$$

Nach Bestimmung der äquivalente Leistung und konstanter Drehzahl, erfolgt die Getriebeauslegung dann wie die Getriebeauswahl gemäß dem in diesem Katalog beschriebenen Verfahren für konstante Leistung.



# Genel Bilgiler

## General Information

### Einführung



#### Redüktör Seçimi

Bir redüktör seçiminde aşağıdaki yol izlenmelidir.

1. Çalışma şartlarına bağlı olarak servis faktörünü (fs) belirleyiniz. (Servis Faktörü Sayfa 18).

2. Makinanız için gerekli olan momenti belirleyiniz  $M_2$  (redüktör gerekli çıkış momenti ).

3. Makinanızın devrini belirleyiniz  $n_2$  (redüktör gerekli çıkış devri ).

4. Makinanızın güç ihtiyacını (Redüktör çıkış gücünü) " $P_2$ " hesaplayınız.

$$P_2 = \frac{M_2 \times n_2}{9550}$$

5. Redüktör ile makina arasında kullanılan bağlantı elemanına göre radyal yükü hesaplayınız. (Sayfa 20). Yukarıdaki verilere uygun olarak çıkış devri, değerlerine uyan servis faktörü ve radyal yükü bulduğunuzdan daha yüksek veya eşit olan redüktörü, güç-devir seçim tablolarından seçiniz. Helisel tip redüktörlerde verim yüksek olduğundan çıkış gücü verilmemiştir. Hesapladığınız güç değerini giriş gücü olarak kabul edip seçiminizi yapınız. Tablolarda verilen  $M_2$  çıkış momentinin hesapladığınız  $M_2$  den büyük olmasına dikkat ediniz. Eğer seçilen redüktörünki daha ufak ise bir üst motor gücüne geçiniz.

#### Örnek

##### 1. Makina Cinsi:

Lastik bantlı konveyör , dökme yük taşıyor.

##### 2. Makina için gerekli moment:

Makina için hesaplanan moment  $M_2 = 470$  Nm.

##### 3. Makina gerekli çıkış devri:

$n_2 = 50$  dev/dak.

##### 4. Günlük çalışma süresi:

16 saat.

##### 5. Saatte start sayısı:

Saatte 1 start

##### 6. Makina ile bağlantı şekli:

Zincir dişli ( çap -130 mm )

- Yük sınıflandırma tablosundan yük sınıfı M olarak seçilir (sayfa 17-18)

- Günlük çalışma süresi 16 saat Saatte start sayısı 1 ve yük sınıfı M'ye tekabül eden servis faktörü tablosundan, servis faktörü için  $fs = 1.3$  değeri bulunur.(sayfa 16)

- Makinanızın güç ihtiyacı (Redüktör Çıkış Gücü) :

$$P_2 = \frac{M_2 \times n_2}{9550} = \frac{470 \times 50}{9550} = 2,46 \text{ kW}$$

#### Gearbox Selection

For the correct selection of the appropriate gear units follow this steps.

1.Determine service factor (fs) on the basis of running conditions (Page 18).

2. Determine the required Torque  $M_2$  (required output torque of gearbox) for the driven machine.

3. Determine required speed (output speed of gearbox) for the driven machine.

4. Calculate the required power for your machine(Calculate power " $P_2$ " required at output side of gear reducer using the formula);

$$P_2 = \frac{M_2 \times n_2}{9550}$$

5. Calculate overhung load required at output shaft according to type of connection between gear unit and machine (Refer to directions and values given on page 20). After determining the above mentioned values, the gear reducer which corresponds to our requirements can be selected from the performance tables (the service factor and the permissible overhung load should be less than or equal to our requirement). For Helical gears the output power is not given on the performance tables because they have high efficiency and the output power can be taken as input power. The output torque should be checked if it meets to our requirements. If the output torque is low, search for a higher input power gearbox.

#### Example:

##### 1. Machine Type:

Belt Conveyor (Bulk Load)

##### 2. Required Torque:

Required Torque calculated for the driven machine is  $M_2=470$  Nm.

##### 3. Required speed:

$n_2 = 50$  rpm

##### 4. Running time:

16 hours per day

##### 5. Frequency of starting:

1 start per hour

##### 6. Connection type between gear reducer

Chain drive (output dimension-130 mm)

- From the load classification table (on page 17-18), the load class M can be selected for the known application.

- The service factor can be selected as  $fs = 1,3$  from the service factor table (page 16) by taking into consideration 16 hours running time, one start per hour, and load class M.

-Required power for your machine(Power at output side of gear reducer) :

$$P_2 = \frac{M_2 \times n_2}{9550} = \frac{470 \times 50}{9550} = 2,46 \text{ kW}$$

#### Getriebeauswahl

Für die korrekte Auswahl des Antriebes;

1. Den Betriebsfaktor(fs) in Abhängigkeit von den Betriebsbedingungen bestimmen.(Bezug auf seite 18).

2. Die erforderte Drehmoment  $M_2$  für die angetriebene Maschine (Abtriebsdrehmoment für die Getriebe) bestimmen.

3. Erforderte Drehzahl bestimmen (Abtriebsdrehzahl für die Getriebe).

4. Berechnen der erforderte Leistung der angetriebene Maschine (Die an der Abtriebswelle erforderte Leistung " $P_2$ ") mit der unten angegebenen Formel.

$$P_2 = \frac{M_2 \times n_2}{9550}$$

5. Die an der Getriebeabtriebswelle erforderte Querkraft in Abhängigkeit von Antriebsselement bestimmen (Bezug auf Seite 20). Nach Bestimmen der oben angegebenen Werte, die passende Getriebe kann von den angegebenen Leistungstabellen entnommen werden. Dabei soll darauf geachtet werden, dass der Betriebsfaktor und Querkraft stets unterhalb von angegebenen Werten liegt. Weil Stirnradgetrieben einen hohen Wirkungsgrad haben, sind die Abtriebsleistungen für Stirnradgetrieben nicht angegeben. Bei dieser Getrieben die erforderte Leistung kann als Antriebsleistung benutzt werden. Achten sie darauf, dass der Abtriebsmoment größer als die erforderte Drehmoment ist.

#### Beispiel:

##### 1. Maschinentyp:

Gurtbandförderer (Schüttgut)

##### 2. Erforderte Drehmoment:

Für die Maschine berechnete Drehmoment  $M_2 = 470$  Nm.

##### 3. Erforderte Drehzahl:

$n_2 = 50$  upm

##### 4. Betriebsdauer:

16 stunden pro Tag

##### 5. Schalthäufigkeit:

1 Start pro Stunde

##### 6. Antriebselement für verbindung

Getriebe-Machine:Kettentrieb(Durchmesser-130 mm)

- Von den Belastungsart Tabellen(Seite 17-18) nimmt man Belastungsart M

- Für den Schaltungzahl 1 und die Laufzeit16 und für den passenden Belastungsart erhält man Betriebsfaktor  $fs = 1,3$  von Tabelle auf seite 16.

- Erforderte Leistung der angetriebe Maschine (Die an der Getriebeabtriebswelle erforderte Leistung)

$$P_2 = \frac{M_2 \times n_2}{9550} = \frac{470 \times 50}{9550} = 2,46 \text{ kW}$$



## Genel Bilgiler General Information Einführung



- Zincir dişli uygulaması için (Sayfa 23) Fq değeri;

$$F_q = \frac{2100 \times M_2}{D} = \frac{2100 \times 470}{130} = 7592 \text{ N}$$

- Ortaya çıkan redüktör ihtiyacı

$$\begin{aligned} P_2 &\geq 2,46 \text{ kW} \\ M_2 &\geq 470 \text{ Nm} \\ fs &\geq 1.3 \\ n_2 &\approx 50 \text{ d/dak} \\ F_q &\geq 7592 \text{ N} \end{aligned}$$

Güç ve devir sayılarından,

**KR373-100L/4b** seçilir (Sayfa 64).

$$\begin{aligned} P_2 &= 3 \text{ kW} > 2,46 \text{ kW} \\ M_2 &= 555 \text{ Nm} > 470 \text{ Nm} \\ fs &= 1,5 \\ n_2 &= 49 \text{ d/dak} \\ fq &= 13213 \text{ Nm} < 7592 \text{ Nm} \\ i &= 28,85 \end{aligned}$$

- For chain drive application the requested overhang load can be calculated from (page 23);

$$F_q = \frac{2100 \times M_2}{D} = \frac{2100 \times 470}{130} = 7592 \text{ N}$$

- The required gearbox is as follows:

$$\begin{aligned} P_2 &\geq 2,46 \text{ kW} \\ M_2 &\geq 470 \text{ Nm} \\ fs &\geq 1.3 \\ n_2 &\approx 50 \text{ rpm} \\ F_q &\geq 7592 \text{ N} \end{aligned}$$

From the performance table,

**KR373-100L/4b** selected (Page 64).

$$\begin{aligned} P_2 &= 3 \text{ kW} > 2,46 \text{ kW} \\ M_2 &= 555 \text{ Nm} > 470 \text{ Nm} \\ fs &= 1,5 \\ n_2 &= 49 \text{ rpm} \\ fq &= 13213 \text{ Nm} < 7592 \text{ Nm} \\ i &= 28,85 \end{aligned}$$

- Für Kettentrieb die erforderte Querkraft (seite 23);

$$F_q = \frac{2100 \times M_2}{D} = \frac{2100 \times 470}{130} = 7592 \text{ N}$$

- Von den oben angegebenen Berechnungen die erforderte Getriebe ist wie folgt;

$$\begin{aligned} P_2 &\geq 2,46 \text{ kW} \\ M_2 &\geq 470 \text{ Nm} \\ fs &\geq 1.3 \\ n_2 &\approx 50 \text{ U/min} \\ F_q &\geq 7592 \text{ N} \end{aligned}$$

Von der Leistung- DrehzahlTabelle ,

wurde **KR373-100L/4b** gewählt (Seite 64).

$$\begin{aligned} P_2 &= 3 \text{ kW} > 2,46 \text{ kW} \\ M_2 &= 555 \text{ Nm} > 470 \text{ Nm} \\ fs &= 1,5 \\ n_2 &= 49 \text{ U/min} \\ fq &= 13213 \text{ Nm} < 7592 \text{ Nm} \\ i &= 28,85 \end{aligned}$$

dalyan®



# Genel Bilgiler

## General Information

### Einführung



### Redüktör Seçim Formu

Kullanıldığı Sektör.....  
Kullanıldığı Yer.....  
Gerekli Ortalama Devir.....d/dak

#### Makina ihtiyaç gücü:

-Normal..... kW  
-En çok..... kW  
-En az..... kW

#### Tahrik Şekli:

AC Motor [ ]  
AC Motor + Invertör [ ]  
DC Motor [ ]  
Hidromotor [ ]  
1-3 silindri içten yanmalı [ ]  
2-4 silindri içten yanmalı [ ]

#### Motor Bağlantı Şekli (Elektrik Motorları):

IEC B5 Flanşlı [ ]  
NEMA Flanşlı [ ]

IEC veya NEMA flanş kodu.....

#### Motor Gücü:

-Nominal..... kW

#### Motor Devri:

-Normal..... d/dak  
-En çok..... d/dak  
-En az..... d/dak

#### Motor Torku:

-Normal..... Nm  
-En çok..... Nm  
-En az..... Nm

#### Dönüş şekli:

saat yönü [ ] saat yönüne ters [ ] değişken [ ]

#### Günlük çalışma süresi:

<4 [ ] 4-8 [ ] 8-16 [ ] >16 [ ]

#### Saatdeki start sayısı:

0-50 [ ] 50-100 [ ] 100-200 [ ]  
200-300 [ ] 300-500 [ ] 500-700 [ ]  
700-1000 [ ] >1000 [ ]

Motor Redüktör Arası Tahvil Oranı.....

Kalkış için gerekli moment.....Nm

#### Saatdeki pik moment adedi:

1-5 [ ] 6-30 [ ] 31-100 [ ] >100 [ ]

#### Bir çevrimde aktif çalışma oranı (ED):

%100 [ ] %80 [ ] %60 [ ] 40% [ ] %20 [ ]

#### Deniz seviyesinden yükseklik:

<1000 [ ] <2000 [ ] <3000 [ ]  
<4000 [ ] <5000 [ ]

#### Montaj yeri:

Küçük kapalı oda (w<1m/sn) [ ]  
Kapalı oda (w<3m/sn) [ ]  
Büyük oda ve holler (w>=3m/sn) [ ]  
Tamamen açık ortam [ ]

#### Çevre Şartları:

Normal [ ] Tozlu [ ] Nemli [ ]  
Korozif [ ] Kuru [ ]

#### Çevre Sıcaklığı:

Ortalama..... °C  
En Yüksek..... °C  
En Düşük..... °C

#### Kilit İhtiyacı:

Var [ ] Yok [ ]

#### Redüktör Giriş Opsiyonu:

R.. [ ] V.. [ ] N.. [ ] T.. [ ]

#### Redüktör Çıkış Opsiyonu:

00 [ ] 01 [ ] 02 [ ] 03 [ ] 04 [ ] 05 [ ] 08 [ ]  
0S [ ] 0E [ ]

#### Montaj Pozisyonu:

M1 [ ] M2 [ ] M3 [ ] M4 [ ] M5 [ ] M6 [ ]

#### Giriş mili bağlantı şekli:

Elastik kaplin [ ]  
Fıçı tipi kaplin [ ]  
Rijit kaplin [ ]  
Hidrolik Kaplin [ ]  
Kayış kasnak [ ]  
Zincir dişli [ ]  
Pinyon dişli [ ]  
Bağlantı elemanı çapı.....mm  
Radyal yükü.....N  
Radyal yük "u" mesafesi.....mm  
Aksiyal yükü (mile doğru +).....N

#### Çıkış mili bağlantı şekli:

Elastik kaplin [ ]  
Fıçı tipi kaplin [ ]  
Rijit kaplin [ ]  
Kayış kasnak [ ]  
Zincir dişli [ ]  
Pinyon dişli [ ]  
Delik milli tork kolu [ ]  
Sıkma bilezikli tork kolu [ ]  
Bağlantı elemanı çapı.....mm  
Radyal yükü.....N  
Radyal yük "u" mesafesi.....mm  
Aksiyal yükü (mile doğru +).....N

#### Çıkış Mili Özelliği:

Dolu Mil Kamalı [ ]  
Dolu Mil Kamasız [ ]  
Delik Milli Sıkma Bilezikli [ ]  
Delik Milli [ ]  
Özel Mil [ ]

#### Giriş Mili Özelliği:

Kamalı [ ]  
Kamasız düz mil [ ]  
Özel Mil [ ]  
Tork kolu [ ] Var [ ] Yok [ ]

#### Elektrik Gerilimi:

AC-Monofaze [ ] AC-Trifaze [ ] DC [ ]  
Voltaj..... Volt  
Frekans..... Hz

#### Koruma Sınıfı:

IP55 [ ] IP65 [ ] Exproof [ ]  
Diğer IP.....

#### Ekler:

Yük diyagramı [ ]  
Proje [ ]  
İstenen ana boyutlar [ ]  
Teknik veriler [ ]

#### Diğer Notlar:



# Genel Bilgiler

## General Information

### Einführung



#### Gearbox Selection Form

Field of Industry.....  
 Application.....  
 Required Average Speed..... rpm

#### Required Power on Driven Machine:

-Normal..... kW  
 -Maximum..... kW  
 -Minimum..... kW

#### Driving Machine:

AC Motor [ ]  
 AC Motor + Inverter [ ]  
 DC Motor [ ]  
 Hydraulic Motor [ ]  
 Piston Engine with 1-3 cylinder [ ]  
 Piston Engine with 4-24 cylinder [ ]

#### Motor Connection Type (Electric Motors):

IEC B5 Flange [ ]  
 NEMA Flange [ ]

IEC or NEMA Flange Code.....

#### Motor Power:

-Nominal.....kW

#### Motor Speed:

-Normal.....rpm  
 -Maximum.....rpm  
 -Minimum.....rpm

#### Motor Torque:

-Normal.....Nm  
 -Maximum.....Nm  
 -Minimum.....Nm

#### Direction of Rotation:

cw [ ] ccw [ ] variable [ ]

#### Working hours per day:

<4 [ ] 4-8 [ ] 8-16 [ ] >16 [ ]

#### Startings per cycle:

0-50 [ ] 50-100 [ ] 100-200 [ ]  
 200-300 [ ] 300-500 [ ] 500-700 [ ]  
 700-1000 [ ] >1000 [ ]

Transmission ratio between motor and gear unit.....

Required Starting Torque.....Nm

#### Peak torques per hour:

1-5 [ ] 6-30 [ ] 31-100 [ ] >100 [ ]

#### Effective working time in a cycle (ED):

%100 [ ] %80 [ ] %60 [ ] 40% [ ]  
 20% [ ]

#### Altitude:

<1000 [ ] <2000 [ ] <3000 [ ]  
 <4000 [ ] <5000 [ ]

#### Mounting Place:

Small closed room (w<1m/sn) [ ]  
 Closed room (w<3m/sn) [ ]  
 Big rooms and halls (w>=3m/sn) [ ]  
 Outdoor [ ]

#### Ambient Conditions:

Normal [ ] Dusty [ ] Humid [ ]  
 Corrosive [ ] Dry [ ]

#### Ambient Temperature:

Average.....°C  
 Maximum.....°C  
 Minimum.....°C

#### Backstop Required:

Yes [ ] No [ ]

#### Gearbox input options:

R.. [ ] V.. [ ] N.. [ ] T.. [ ]

#### Gearbox output options:

00 [ ] 01 [ ] 02 [ ] 03 [ ] 04 [ ] 05 [ ] 08 [ ]  
 0S [ ] 0E [ ]

#### Mounting Position:

M1 [ ] M2 [ ] M3 [ ] M4 [ ] M5 [ ] M6 [ ]

#### Input Shaft Connection Type:

Elastic Coupling [ ]  
 Barrel Type Coupling [ ]  
 Hydraulic Coupling [ ]  
 Rigid Flange Coupling [ ]  
 Pulley [ ]  
 Chain Sprocket [ ]  
 Pinion [ ]  
 Diameter of Connection element.....mm  
 Radial Load.....N  
 "u" Distance of Radial Load.....mm  
 Axial Load (Towards Shaft) .....N

#### Output Shaft Connection Type:

Elastic Coupling [ ]  
 Barrel Type Coupling [ ]  
 Rigid Flange Coupling [ ]  
 Pulley [ ]  
 Chain Sprocket [ ]  
 Pinion [ ]  
 Hollow Shaft with Torque Arm [ ]  
 Shrinck disc with Torque Arm [ ]  
 Diameter of Connection Element.....mm  
 Radial Load.....N  
 "u" Distance of Radial Load.....mm  
 Axial Load (Towards Shaft) .....N

#### Gearbox assembled by:

Foot [ ] Flange [ ] Torque Arm [ ]

#### Output Shaft Specification:

Solid Shaft with Keyway [ ]  
 Solid Shaft without Keyway [ ]  
 Hollow Shaft with Shrinck Disc [ ]  
 Hollow Shaft [ ]  
 Special Shaft [ ]

#### Input Shaft Specification:

Solid Shaft with Keyway [ ]  
 Solid Shaft without Keyway [ ]  
 Special Shaft [ ]  
 Torque arm required Yes [ ] No [ ]

#### Electrical Supply:

AC-1 Phase [ ] AC-3 Phase [ ] DC [ ]  
 Voltage.....Volt  
 Frequency..... Hz

#### Protection Class:

IP55 [ ] IP65 [ ] Exproof [ ]  
 Other IP.....

#### Attachments:

Load Diagram [ ]  
 Project [ ]  
 Required Dimensions [ ]  
 Technical Specifications [ ]

#### Notes:



# Genel Bilgiler

## General Information

### Einführung



#### Formular für Getriebeauswahl

Industriebereich.....  
 Anwendung.....  
 Erforderliche Drehzahl.....U/min

#### Erforderliche Leistung für die Maschine:

-Normal.....kW  
 -Minimal.....kW  
 -Maximal.....kW

#### Antriebsmaschine:

AC Motor [ ]  
 AC Motor mit Frequenzumrichter [ ]  
 DC Motor [ ]  
 Hydromotor [ ]  
 Kolbenmaschinen mit 1-3 Zylinder [ ]  
 Kolbenmaschinen mit 2-4 Zylinder [ ]

#### Motorverbindungsart (Elektromotoren):

IEC B5 Flansch [ ]  
 NEMA Flansch [ ]

IEC oder NEMA Flanschcode.....

#### Motorleistung:

-Nominal.....kW

#### Motordrehzahl:

-Normal.....U/min  
 -Maximal.....U/min  
 -Minimal.....U/min

#### Motordrehmoment:

-Normal.....Nm  
 -Maximal.....Nm  
 -Minimal.....Nm

#### Drehrichtung:

in Uhrzeigersinn [ ] gegen Uhrzeigersinn [ ]  
 veränderlich [ ]

#### Betriebsdauer in Stunden pro Tag:

<4 [ ] 4-8 [ ] 8-16 [ ] >16 [ ]

#### Anzahl der Anläufe pro Stunde:

0-50 [ ] 50-100 [ ] 100-200 [ ]  
 200-300 [ ] 300-500 [ ] 500-700 [ ]  
 700-1000 [ ] >1000 [ ]

Übersetzung zwischen Motor und Antriebswelle.....

Erforderliches Anlaufmoment.....Nm

#### Häufigkeit von Lastspitzen pro Stunde:

1-5 [ ] 6-30 [ ] 31-100 [ ] >100 [ ]

#### Einschaltdauer je Stunde (ED):

%100 [ ] %80 [ ] %60 [ ] 40% [ ] %20 [ ]

#### Höhenlage über Meeresspiegel (m):

<1000 [ ] <2000 [ ] <3000 [ ]  
 <4000 [ ] <5000 [ ]

#### Betriebsort:

Kleine geschlossene Räume (w<1m/sn) [ ]  
 Geschlossene Räume (w<3m/sn) [ ]  
 Große Räume und Hallen (w>=3m/sn) [ ]  
 im Freien [ ]

#### Umgebungsbedingungen:

Normal [ ] Staubig [ ] Feucht [ ]  
 Korrodierend [ ] Trocken [ ] Verklebend [ ]

#### Umgebungstemperatur:

Mittelwert.....°C  
 Maximal.....°C  
 Minimal.....°C

#### Rücklaufsperre erforderlich:

Ja [ ] Nein [ ]

#### Getriebeeingangsvarianten:

R.[ ] V.[ ] N.[ ] T.[ ]

#### Getriebeausgangsvarianten:

00 [ ] 01 [ ] 02 [ ] 03 [ ] 04 [ ] 05 [ ] 08 [ ]  
 0S [ ] 0E [ ]

#### Montageposition:

M1 [ ] M2 [ ] M3 [ ] M4 [ ] M5 [ ] M6 [ ]

#### Antriebswellenanschluss:

Elastische Kupplung [ ]  
 Trommelkupplung [ ]  
 Hydrokupplung [ ]  
 Starre Flanschkupplung [ ]  
 Riementrieb [ ]  
 Kettenrad [ ]  
 Ritzel [ ]  
 Durchmesser von Anschlusselement.....mm  
 Querkraft.....N  
 "u" Abstand von der Wellenschulter.....mm  
 Axialkraft (in Richtung der Welle +) .....N

#### Abtriebswellenanschluss:

Elastische Kupplung [ ]  
 Trommelkupplung [ ]  
 Starre Flanschkupplung [ ]  
 Riementrieb [ ]  
 Kettenrad [ ]  
 Ritzel [ ]  
 Hohlwelle mit Drehmomentstütze [ ]  
 Schrumpfscheibe mit Drehmomentstütze [ ]  
 Durchmesser von Anschlusselement.....mm  
 Querkraft.....N  
 "u" Abstand von der Wellenschulter.....mm  
 Axialkraft (in Richtung der Welle +) .....N

#### Montage zur Getriebegehäuse mit:

Fuß [ ] Flansch [ ] Drehmomentstütze [ ]

#### Eigenschaften der Abtriebswelle:

Vollwelle mit Passfeder [ ]  
 Vollwelle ohne Passfeder [ ]  
 Hohlwelle mit Schrumpfscheibe [ ]  
 Hohlwelle [ ]  
 Sonderwelle [ ]

#### Eigenschaften der Antriebswelle:

Vollwelle mit Paßfeder [ ]  
 Vollwelle ohne Paßfeder [ ]  
 Sonderwelle [ ]  
 Drehmomentstütze erforderlich Ja [ ] Nein [ ]

#### Spannungsversorgung:

AC-1 phasig [ ] AC-3 phasig [ ] DC [ ]  
 Spannung.....Volt  
 Frequenz.....Hz







# Genel Bilgiler

## General Information

### Einführung



#### Yağlama

Redüktörlerin uzun ömürlü olması ve iyi performansla çalışabilmesi için, kullanılan yağın seçimi doğru olmalı ve belirtilen zamanlarda değişimleri yapılmalıdır.

Yağın seçiminde devir, çevre sıcaklığı, redüktör yağ sıcaklığı, çalışma koşulları ve yağ ömrü önem taşımaktadır. Redüktörler yağı doldurulmuş olarak sevkedilmektedir. Redüktörler uzun süre depolanacakları zaman veya çalışmaya başlanacağı zaman çalışma konumuna göre üstte kalan tapa sökülmeli ve redüktörün beraberinde verilen havalandırma tapası kullanılmalıdır. Bu redüktörün iç basıncından dolayı oluşacak yağ sızmalarını önleyecektir.

Redüktörlerde standart olarak kullanılan yağlar yan sayfadaki tabloda verilmiştir. Ayaklı redüktörler ve flanşlı redüktörler M1 pozisyonuna göre yağ ile doldurulmuştur. Bu pozisyonlar dışındaki çalışma durumlarında tablolarda verilen yağ miktarlarına göre ilave veya eksiltme yapılmalıdır. Özel çalışma koşullarında firmamıza danışmanız tavsiye edilir.

Mineral yağlar her 10.000 çalışma saatinde, sentetik yağlar ise her 20.000 çalışma saatinde değiştirilmelidir. Ağır çevre koşullarında (ani ısı değişiklikleri, yüksek nemlilik v.b) yağ değiştirme periyotlarının kısaltılması tavsiye edilir. Mineral yağlar ile sentetik yağlar birbirine kesinlikle karıştırılmamalıdır. Değiştirme işlemi bir çalışma periyodunun hemen peşinden ve yağ sıcakken yapılmalıdır. Bu şekilde bir değiştirme, redüktör içindeki partiküllerin yağa karışmış olarak bulunmasından dolayı iyi bir temizleme ve yağın rahat boşalması neticesini verecektir.

Helisel dişli redüktörlerimiz ile E100-E125 sonsuz tip redüktörlerimiz ISO VG320 mineral yağ ile, E030-E080 aralığındaki sonsuz redüktörlerimiz ISO VG320 sentetik yağ ile doldurulmaktadır. Sonsuz vidalı mineral yağlı redüktörlerde ilk 600 çalışma saatinden sonra yağın değiştirilmesi tavsiye edilir. Yağ cinsleri ve çalışma pozisyonlarına göre yağ miktarları takip eden sayfalarda verilmiştir.

#### Lubrication

*To work in perfect condition and to have long life for the gear box the lubricant must be chosen correctly and changed in time.*

*In selection of oil it is important to consider speed, ambient temperature, gear box oil temperature, working conditions and the life required from the lubricant. All units are filled with lubricant before shipping. Before the gearbox is stored for a long time or before starting up, the top plug (according to the working position) must be removed and the extra given vent plug must be replaced. This prevents excessive pressure which causes oil leakages.*

*The lubricant in the standard line is given for standard fillings on the table below. The foot mounting type gear boxes and where the flange mounted gear boxes are filled for mounting position of M1. For other mounting positions please refer to the table given on the next pages. For special working conditions please contact us.*

*The mineral lubricant should be changed after every 10.000 service hours and the synthetic lubricant should be changed after every 20.000 working hours. If the operation conditions are very heavy (e.g. high temperature differences, high humidity) shorter intervals between changes are recommended. Mineral and synthetic oils must not be mixed up. By changing the lubricant complete cleaning is advised. The oil change should be done after a working period. Because oil is hot in this condition and impurities are mixed with it the changing of oil will be done in best result and the oil will drain easily.*

*Helical gear boxes and E100-E125 worm gear boxes are filled with mineral oil ISO VG320, worm gear boxes from E30 up to E80 are filled with synthetic oil ISO VG320. For mineral oil lubricated worm gear boxes, the first oil change is advised after 600 working hours. Oil quantities according to mounting positions are given on the following pages.*

#### Schmierung

Um eine lange Lebensdauer zu gewährleisten muss der Schmierstoff richtig ausgewählt werden.

Für die richtige Ölauswahl müssen Drehzahl, Umgebungstemperatur, Belastungsart und Lebensdauer des Öls berücksichtigt werden. Die mitgelieferte Entlüftungsschraube ist vor Inbetriebnahme oder längeren Lagern gegen die Einfüllschraube auszutauschen, um einen Überdruck im Getriebe und damit eine Undichtigkeit des Getriebes zu vermeiden. Getriebe und Getriebemotoren sind bei Auslieferung betriebsfertig gefüllt.

Ohne besondere Bestellangaben werden die Getriebe grundsätzlich mit den auf der folgenden Seite in der grau unterlegten Spalte angegebenen Schmierstoffen gefüllt. Die fußbefestigten Getriebe sind befüllt für Bauform und die flanschbefestigten Getriebe für Bauform M1. Für andere Bauformen sind die auf der nächsten Seite angegebenen Füllmengen zu beachten.

Ein Schmierstoffwechsel sollte alle 10.000 Betriebsstunden durchgeführt werden. Für synthetische Produkte verdoppeln sich diese Fristen. Bei extremen Betriebsbedingungen, z.B. hohe Luftfeuchtigkeit, aggressiver Umgebung und hohen Temperaturschwankungen sind kürzere Schmierstoffintervalle vorteilhaft. Es ist empfehlenswert, dem Schmierstoffwechsel mit einer gründlichen Reinigung des Getriebes zu verbinden. Synthetische und mineralische Schmierstoffe dürfen nicht miteinander vermischt werden. Das Ablassen des Öls soll unmittelbar nach dem Stillsetzen erfolgen, solange das Öl noch warm ist. In diesem Zustand ist das Öl mit den Schmutzpartikeln vermengt, so dass eine Entfernung des Altöls eine gute Reinigung garantiert.

Alle Stirnrad- und Schneckengetriebe E100 und E125 sind befüllt mit mineralöl. Schneckengetriebe ab einer Baugröße von E030 bis E080 sind mit synthetischem Öl befüllt. Für Mineralölgeschmierte Schneckengetriebe wird ein Ölwechsel nach 600 Betriebsstunden empfohlen. Ölmenge und Öltypen der verschiedenen Bauformen sind auf den folgenden Seiten angegeben.



# Genel Bilgiler

## General Information

### Einführung



#### Yağ Tipleri / Oil Types / Schmierstoffe

Yağ Cinsi Lubricant Art des Schmierers	DIN 51517-3	Çevre Sıcaklığı [°C] Ambient Temp. [°C] Umgebungstemp. [°C]	ISO VG	Aral	Beyond Petroleum	Castrol	Klüber Lubrication	Mobil	Shell	Total
		Daldırma Yağlama Dip Lubrication Tauchschmier.								
Mineral Yağlar Mineral Oil Mineralöl	CLP	0 ... +50	680	Degol BG 680	Energol GR-XP 680	Alpha SP 680	Klüberoil GEM 1-680 N	Mobilgear XMP 680	Omala 680	Carter EP 680
		-5 ... +45	460	Degol BG 460	Energol GR-XP 460	Alpha SP 460	Klüberoil GEM 1-460 N	Mobilgear XMP 460	Omala F460	Carter EP 460
		-10 ... +40	320	Degol BG 320	Energol GR-XP 320	Alpha SP 320	Klüberoil GEM 1-320 N	Mobilgear XMP 320	Omala F320	Carter EP 320
		-15 ... +30	220	Degol BG 220	Energol GR-XP 220	Alpha SP 220	Klüberoil GEM 1-220 N	Mobilgear XMP 220	Omala F220	Carter EP 220
		-20 ... +20	150	Degol BG 150	Energol GR-XP 150	Alpha SP 150	Klüberoil GEM 1-150 N	Mobilgear XMP 150	Omala 150	Carter EP 150
		-25... +10	100	Degol BG 100	Energol GR-XP 100	Alpha SP 100	Klüberoil GEM 1-100 N	-	Omala 100	Carter EP 100
Sentetik Yağlar Synthetic Oil Synthetisches Öl	CLP PG	-10 ... +60	680	Degol GS 680	Energol SG-XP 680	-	Klübersynth GH 6 -680	Mobil Glygoyle 680	Tivela S 680	Carter SY 680
		-20 ... +50	460	Degol GS 460	Energol SG-XP 460	Aphasyn PG 460	Klübersynth GH 6 -460	Mobil Glygoyle 460	Tivela S 460	Carter SY 460
		-25 ... +40	320	Degol GS 320	Energol SG-XP 320	Aphasyn PG 320	Klübersynth GH 6 -320	Mobil Glygoyle 320	Tivela S 320	Carter SY 320
		-30 ... +30	220	Degol GS 220	Energol SG-XP 220	Aphasyn PG 220	Klübersynth GH 6 -220	-	Tivela S 220	Carter SY 220
		-35 ... +20	150	Degol GS 150	Energol SG-XP 150	Aphasyn PG 150	Klübersynth GH 6 -150	-	Tivela S 150	Carter SY 150
		-40 ... +10	100	-	-	-	Klübersynth GH 6 -100	-	-	-
	CLP HC	-10 ... +60	680	-	-	-	Klübersynth GEM 4-680 N	Mobilgear SHC XMP 680	-	Carter SH 680
		-20 ... +50	460	Degol PAS 460	Energol EP-XF 460	Alphasyn T 460	Klübersynth GEM 4-460 N	Mobilgear SHC XMP 460	Omala HD 460	Carter SH 460
		-25 ... +40	320	Degol PAS 320	Energol EP-XF 320	Alphasyn T 320	Klübersynth GEM 4-320 N	Mobilgear SHC XMP 320	Omala HD 320	Carter SH 320
		-30 ... +30	220	Degol PAS 220	Energol EP-XF 220	Alphasyn T 220	Klübersynth GEM 4-220 N	Mobilgear SHC XMP 220	Omala HD 220	Carter SH 220
		-35 ... +20	150	Degol PAS 150	Energol EP-XF 150	Alphasyn T 150	Klübersynth GEM 4-150 N	Mobilgear SHC XMP 150	Omala HD 150	Carter SH 150
		-40 ... +10	100	-	-	-	Klübersynth GEM 4-100 N	-	-	-
Gıda Uyumlu Yağ Food Grade Oil Lebensmittelöl	CLP NSF H1	-15 ... +25	320	-	-	Optileb GT 320	Klüberoil 4 UH1-320 N	Mobil SHC Cibus 320	Cassida Fluid GL-320	Nevastane SL 320
Çevre Dostu Yağ Biodegradable Oil Biologisch abbaubares Öl	CLP E	-25 ... +40	320	-	-	Tribol BioTop 1418-320	Klübersynth GEM 2-320	-	-	Carter Bio 320
Mineral Gresler [ -20 .... +120 Çalışma Sıcaklığı °C] Mineral Grease [ -20 .... +120 Working Temperature °C] Mineral-Fett [ -20 .... +120 Betriebstemperatur °C]				Aralub HL3	Energol LS 3	Spheerol AP3	Centoplex 2 EP	Mobilux EP 3	Alvania RL3	Multis Complex EP 2
Sentetik Gresler [ -30 .... +100 Çalışma Sıcaklığı °C] Synthetic Grease [ -30 .... +100 Working Temperature °C] Synthetisches Fett [ -30 .... +100 Betriebstemperatur °C]				-	Energol SY 2202	-	Petamo GHY 133 N	Mobiltemp SHC 100	Cassida RLS 2	Multis Complex SHD 220



# Genel Bilgiler

## General Information

### Einführung



Montaj Pozisyonları / Mounting Positions / Bauformen

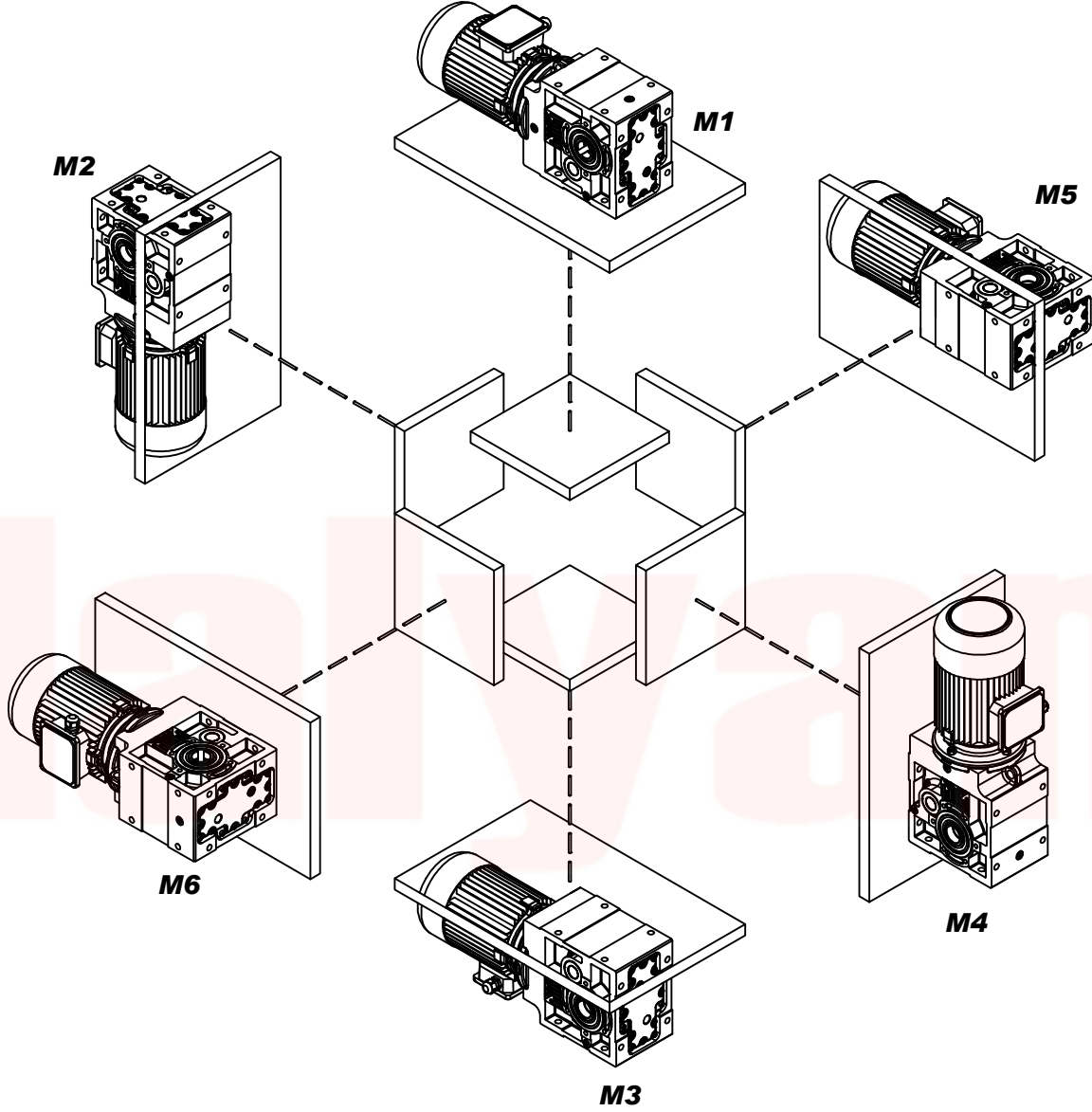

M1....M6 'ya kadar belirtilen montaj pozisyonları redüktörün duruş yönü referans alınarak belirlenmiştir. Montaj yüzeyleri bağlayıcı değildir.  
Figured mounting positions of M1 to M6 are determined as reference of directional position of the gearbox. Mounting surfaces are not binding.  
Dargestellte Montagepositionen M1 bis M6 wurden nach der Stehrichtung von Getriebe bestimmt. Montageoberflächen sind unverbindlich.



# Genel Bilgiler

## General Information

### Einführung



### Üç Kademeli Helisel-Konik Dişli Redüktörler Yağ Seviye Tapaları

Three Stage Helical-Bevel Geared Gearboxes Oil Level Plugs

Zwei-Dreistufig Stirnradgetriebe mit Hohlwelle Ölverschlußschrauben

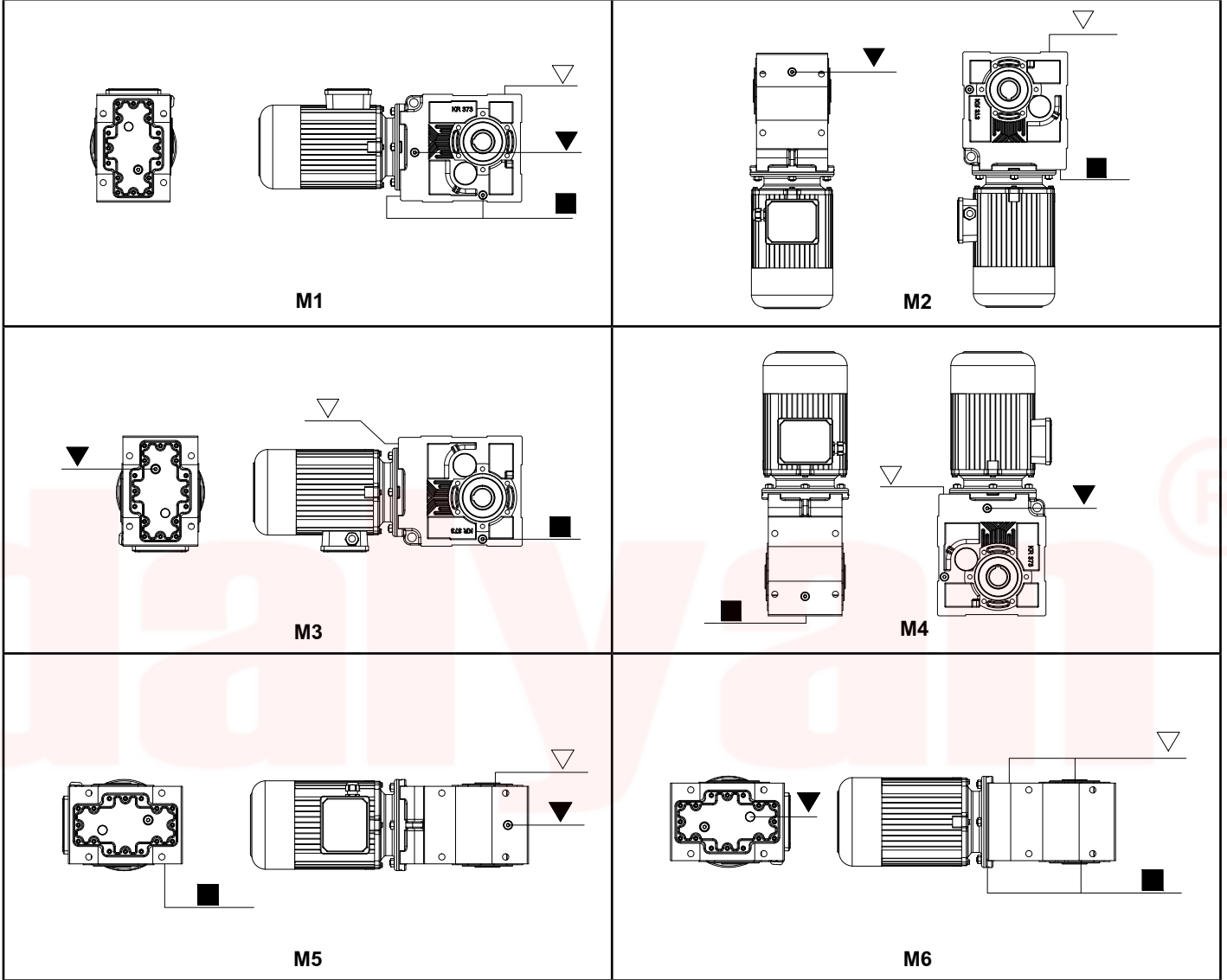

### Yağ Miktarları (lt) / Oil Quantities (lt) / Ölmengen (liter)

Tip / Type / Typ	M1	M2	M3	M4	M5	M6
KR273	1,3	2,0	2,0	2,1	1,5	1,3
KR373	2,1	3,3	3,2	3,7	2,4	2,8
KR473	5,0	6,5	6,0	7,0	4,8	5,5
KR573	6,5	9,5	9,5	10,0	7,5	8,0
KR673	15,0	19,0	19,0	20,5	18,0	17,0
KR773	21,0	31,0	29,0	34,0	25,0	21,0
KR873	37,0	50,0	50,0	60,0	45,0	39,0

Semboller : : Yağ boşaltma  
Symbols : ■ : Drain plug  
Symbole : : Ölauslass

▽ : Yağ doldurma ve havalandırma  
▽ : Oil Filling and Vent plug  
▽ : Öfüllung und Entlüftung

▽ : Yağ seviyesi  
▽ : Oil level  
▽ : Ölstand



# Genel Bilgiler

## General Information

### Einführung



**Dört Kademeli Helisel-Konik Dişli Redüktörler Yağ Seviye Tapaları**  
*Four Stage Reduction Helical-Bevel Geared Gearboxes Oil Level Plugs*  
Vierstufig Stirnradgetriebe mit Hohlwelle Ölverschlußschrauben

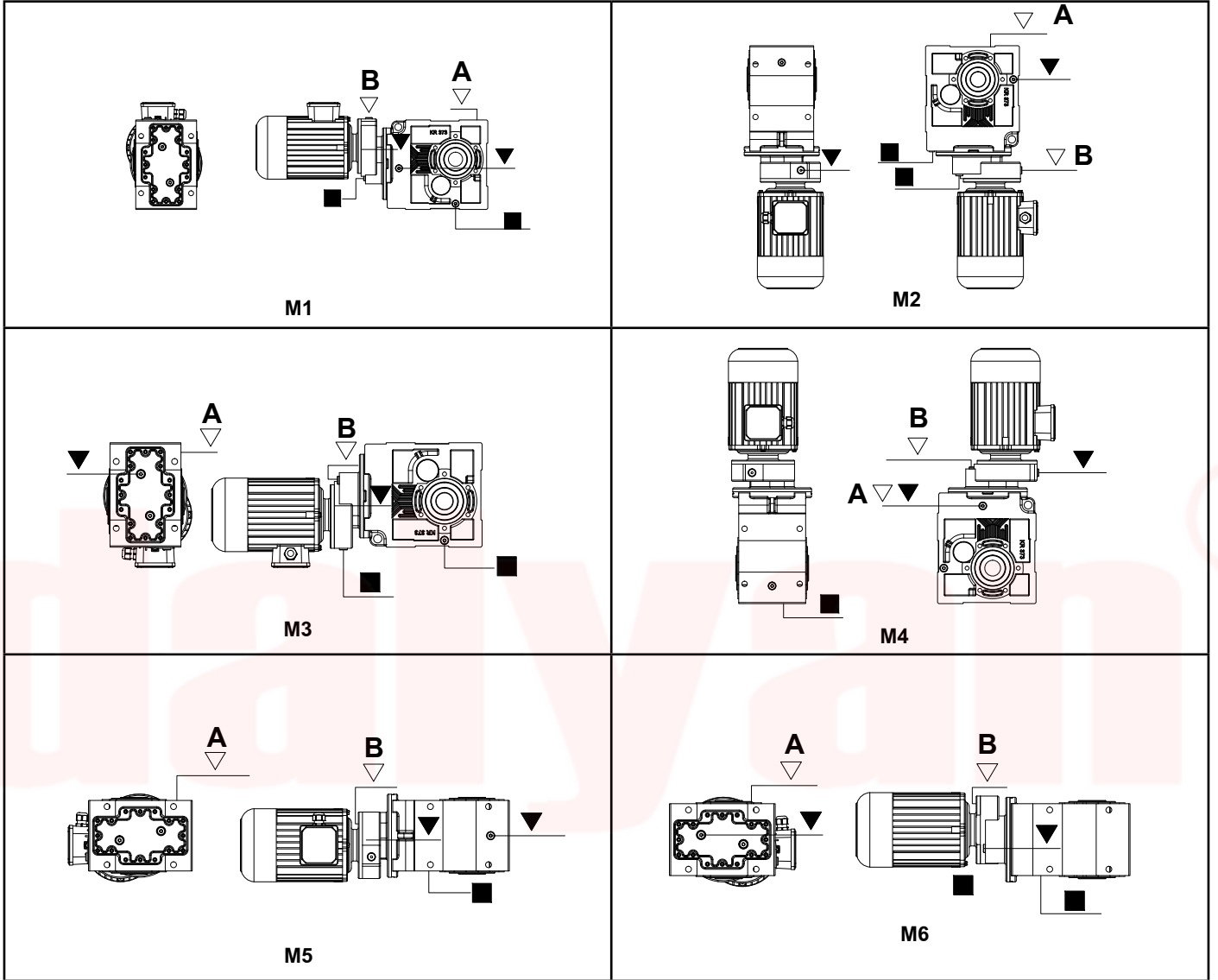

**Yağ Miktarları (lt) / Oil Quantities (lt) / Ölmengen (liter)**

Tip / Type / Typ	M1 A / B	M2 A / B	M3 A / B	M4 A / B	M5 A / B	M6 A / B
KR374	2,1 / 0,25	3,3 / 0,7	3,2 / 0,25	3,7 / 0,25	2,4 / 0,25	2,8 / 0,25
KR474	5,0 / 0,4	6,5 / 1,5	6,0 / 0,4	7,0 / 0,4	4,8 / 0,4	5,5 / 0,4
KR574	6,5 / 0,5	9,5 / 1,5	9,5 / 0,5	10,0 / 0,5	7,5 / 0,5	8,0 / 0,5
KR674	15,0 / 0,9	19,0 / 4,0	19,0 / 0,9	20,5 / 0,9	18,0 / 0,9	17,0 / 1,0
KR774	21,0 / 1,0	29,0 / 4,0	29,0 / 1,0	34,0 / 1,0	25,0 / 1,0	21,0 / 1,0
KR874	37,0 / 2,15	50,0 / 4,0	50,0 / 2,15	60,0 / 2,15	45,0 / 2,15	39,0 / 2,15

Semboller :  
Symbols :  
Symbole :

: Yağ boşaltma  
■ : Drain plug  
: Ölauslass

: Yağ doldurma ve havalandırma  
▽ : Oil Filling and Vent plug  
: Ölfüllung und Entlüftung

: Yağ seviyesi  
▼ : Oil level  
: Ölstand



# Genel Bilgiler

## General Information

### Einführung



#### Beş-Altı Kademeli Helisel-Konik Dişli Redüktörler Yağ Seviye Tapaları

Five-Six Stage Helical-Bevel Geared Gearboxes Oil Level Plugs

Fünf-Sechsstufig Stirnradgetriebe mit Hohlwelle Ölverschlußschrauben

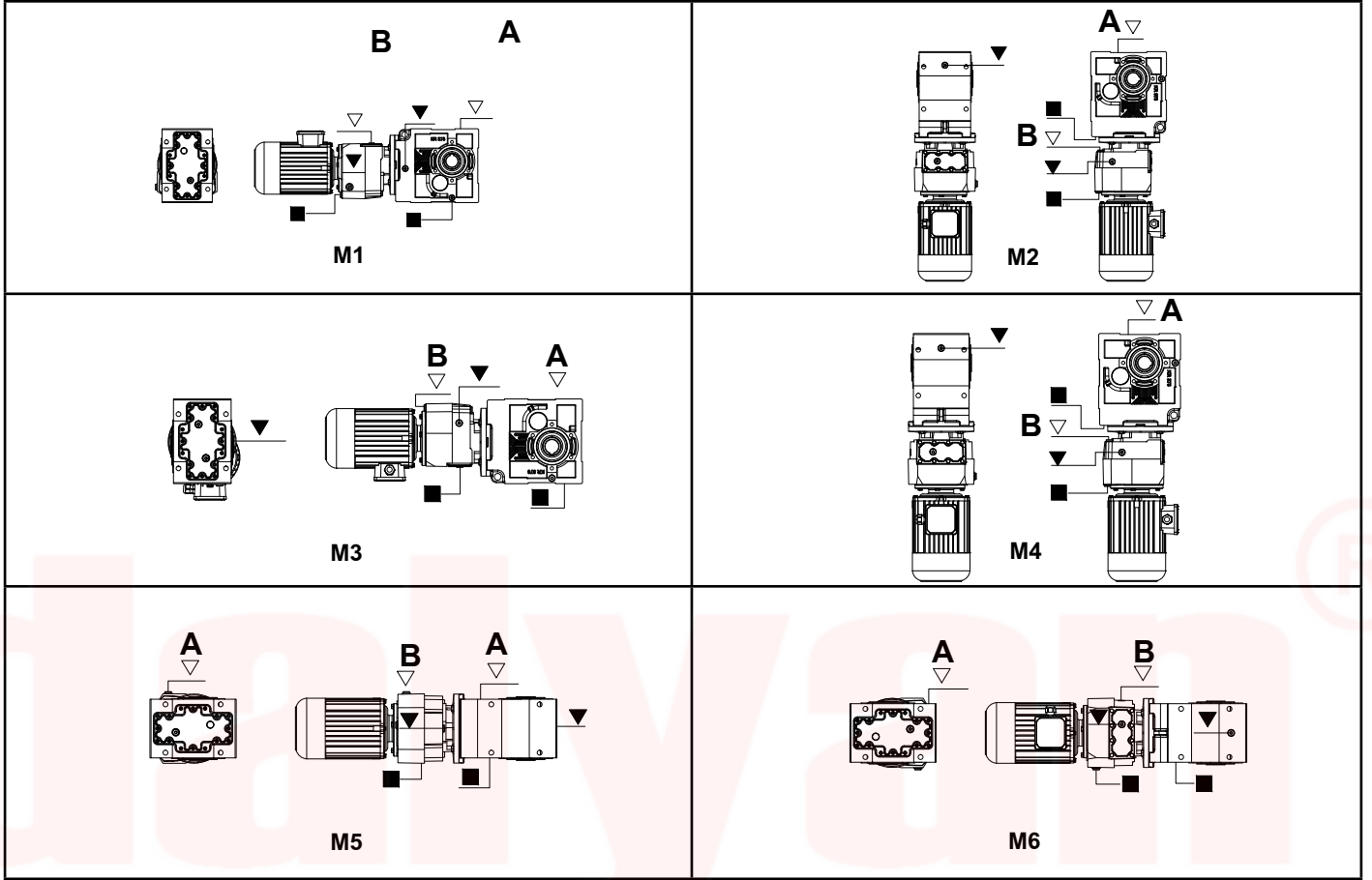

#### Yağ Miktarları (lt.) / Oil Quantities. (lt) / Ölmengen (liter)

Tip / Type / Typ	M1 A/B	M2 A/B	M3 A/B	M4 A/B	M5 A/B	M6 A/B
K.275	1.3 / 0.4	2.0 / 0.6	2.0 / 0.5	2.1 / 0.6	1.5 / 0.5	1.3 / 0.5
K.375	2.1 / 0.65	3.3 / 0.95	3.2 / 0.7	3.7 / 0.95	2.4 / 0.7	2.8 / 0.7
K.475	5.0 / 1.2	6.5 / 2.1	6.0 / 2.0	7.0 / 2.1	4.8 / 1.4	5.5 / 1.4
K.575	6.5 / 1.2	9.5 / 2.1	9.5 / 2.0	10 / 2.1	7.5 / 1.4	8 / 1.4
K.675	15 / 2	19 / 3.4	19 / 3.1	20.5 / 3.4	18 / 2.8	17 / 2.8
K.775	21.0 / 2	31 / 3.4	29 / 3.1	34 / 3.4	25 / 2.8	21 / 2.8
K.875	37.0 / 2	50.0 / 3.4	50.0 / 3.1	60.0 / 3.4	45.0 / 2.8	39.0 / 2.8
K.276	1.3 / 0.35	2.0 / 0.55	2.0 / 0.5	2.1 / 0.55	1.5 / 0.4	1.3 / 0.4
K.376	2.1 / 0.6	3.3 / 0.8	3.2 / 0.7	3.7 / 0.8	2.4 / 0.65	2.8 / 0.65
K.476	5.0 / 1.1	6.5 / 2	6.0 / 1.9	7.0 / 2	4.8 / 1.3	5.5 / 1.3
K.576	6.5 / 1.9	9.5 / 3.3	9.5 / 3	10 / 3.3	7.5 / 2.6	8 / 2.6
K.676	15 / 1.9	19 / 3.3	19 / 3	20.5 / 3.3	18 / 2.6	17 / 2.6
K.776	21.0 / 1.9	31 / 3.3	29 / 3	34 / 3.3	25 / 2.6	21 / 2.6
K.876	37.0 / 1.9	50.0 / 3.3	50.0 / 3	60.0 / 3.3	45.0 / 2.6	39.0 / 2.6

Semboller : : Yağ boşaltma  
Symbols : ■ : Drain plug  
Symbole : : Ölauslass

▽ : Yağ doldurma ve havalandırma  
▽ : Oil Filling and Vent plug  
▽ : Ölfüllung und Entlüftung

▼ : Yağ seviyesi  
▼ : Oil level  
▼ : Ölstand



# Genel Bilgiler

## General Information

### Einführung



#### MOTORLAR

##### AC Motorlar

##### a- Genel Özellikler:

Basit konstrüksiyonlu, bakım gerektirmez, güvenilirliği yüksek ve uygun fiyatlı olmaları nedeni ile trifaze asenkron motorlar en çok kullanılan motor cinsidir. Bu motorların çalışma karakteristikleri moment-hız eğrisi ile belirlenir. Aşağıda bu karakteristik eğrisine bir örnek verilmiştir.

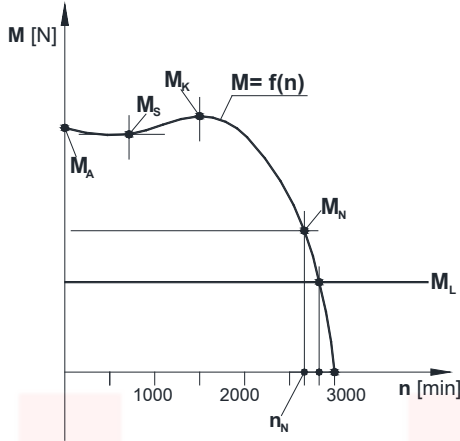

Motorun her start yapılmasında bu eğriye uygun hareket eder ve yük momentini  $M_L$  ile bu eğrinin çakıştığı noktada, motorun çalışma anındaki moment ve devirini verir.

Statorun manyetik alanı senkron hızla  $n_s$  döner. Kutuplar arasındaki faz kayması 3 fazlı motorlarda  $120^\circ$  'dir.

$$n_s = 120 \times \frac{f}{p_s}$$

f.....: şebeke frekansı [Hz]  
p\_s.....: statorun kutup sayısı

Rotorun değişken manyetik alanı rotorun statorun manyetik alanının dönüşü yönünde dönmeye başlamasını sağlar. Rotor bu hareketinde statorun manyetik alanını takip eder ama hiçbir zaman yakalayamaz. Rotor statorun manyetik alanının hızından yavaş döner. Rotorun bu hızına baz hız  $n_N$  denir. Yükün azalması rotorun hızının artmasını sağlar, aynı zamanda sapma azalmış olur. Sapma aşağıdaki gibi belirlenmiştir:

$$s = \frac{n_s - n_N}{n_s} \times 100$$

Sapmanın miktarına göre motorun nominal değerlerinde şu farklılıklar olabilir.

Sapma s .....:  $\pm 20\%$   
Kalkış Akımı.....:  $\pm 20\%$   
Kalkış Momenti.....:  $-15 / +25 \%$   
Kütle Atalet Momenti.....:  $\pm 10\%$   
Verim (37 kW'a kadar).....:  $-0,15 (1-\eta)$

#### MOTORS

##### AC Motors

##### a- General Specifications:

On account of its simple and maintenance free construction, good reliability and price, the three phase squirrel cage motor is one of the most frequently employed electric motors. The run up behavior of a three phase squirrel cage motor is described by the torque-speed characteristic curve. An example is shown below.

$M_A$ : Start moment / Starting torque / Anlaufmoment

$M_S$ : Demeraj moment / Pull-up torque / Anziehungsmoment

$M_K$ : Frenleme moment / Pull-out torque / Bremsmoment

$M_N$ : Motorun iletmediği moment / Motor rated torque / Treibmoment

$M_L$ : Yük moment / Load torque / Lastmoment

The motor follows this torque characteristics up to its stable operating point every time, when it is switched on. Operating point is that point, where the moment speed curve intersects with load torque  $M_L$  line.

The magnetic field in the stator rotates at a synchronous speed  $n_s$ . Phase shift of each pole is  $120^\circ$  at 3 phase motors.

$$n_s = 120 \times \frac{f}{p_s}$$

f.....: supply frequency [Hz]  
p\_s.....: number of stator poles

Because of the alternating magnetic field in the rotor, the rotor starts running in the same direction of the stator flux and tries to catch up with the rotating flux. The rotor never catches up the stator field. The rotor runs slower than the speed of the stator field. This speed is called the base speed  $n_N$ .

A decrease in load will cause the rotor to speed up or decrease slip. The slip is defined as follows:

$$s = \frac{n_s - n_N}{n_s} \times 100$$

According to the slip, the nominal values of the electric motor can alter as follows:

Slip s .....:  $\pm 20\%$   
Starting current .....:  $\pm 20\%$   
Starting torque .....:  $-15 / +25 \%$   
Moment of inertia.....:  $\pm 10\%$   
Efficiency (up to 37 kW).....:  $-0,15 (1-\eta)$

#### MOTOREN

##### Drehstrommotoren:

##### a- Allgemeine Eigenschaften

Wegen die wartungsarme und leichte Konstruktion, hohe Sicherheit bei Nutzung und günstige Preise werden die asynchrone Drehstrommotoren am meisten benutzt. Motoranlaufverhalten wird mit Moment-Drehzahl-Kurve charakterisiert. Ein Beispiel ist unten angegeben.

Der Drehstrommotor läuft diese Kurve bei jeder Anlauf, bis dem stabilen Betriebspunkt erreicht wird. Betriebspunkt ist der Zustand, bei dem die Moment-Drehzahl-Kurve sich mit der Linie von erforderlichen Moment  $M_L$  schneidet.

Magnetisches Feld von Stator dreht sich mit synchroner Geschwindigkeit  $n_s$ . Phasenverschiebung von den Polen ist  $120^\circ$  bei 3phasigen Drehstrommotoren.

$$n_s = 120 \times \frac{f}{p_s}$$

f.....: Frequenz der Spannung [Hz]  
p\_s.....: Anzahl der Polen von Stator

Durch das magnetische Wechselfeld in den Rotor, beginnt der Rotor sich in der gleichen Richtung des Statorflusses zu drehen und versucht diese Bewegung aufzuholen. Der Rotor kann den Statorfeld nie aufholen. Die Rotorgeschwindigkeit nennt man Basisgeschwindigkeit  $n_N$ . Eine Abnahme der Belastung bewirkt, dass der Rotor sich beschleunigt und der Schlupf sich verringert. Der Schlupf wird wie folgt definiert:

$$s = \frac{n_s - n_N}{n_s} \times 100$$

Für die nominale Werte der Drehstrommotoren sind folgende Abweichungen zulässig:

Schlupf s .....:  $\pm 20\%$   
Anzugsstrom .....:  $\pm 20\%$   
Anzugsmoment .....:  $-15 / +25 \%$   
Massentägheitsmoment .....:  $\pm 10\%$   
Wirkungsgrad (bis 37 kW).....:  $-0,15 (1-\eta)$





# Genel Bilgiler

## General Information

### Einführung



#### b- Çalışma Türleri

Katalogta verilen tüm redüktörlerin motorları S1 çalışma türüne uygun verilmektedir. Diğer çalışma türleri aşağıdaki tabloda gösterilmiştir.

#### b-Modes of Operation

All motors of the catalogue have been laid out for duty S1 (continuous operation). Other duty types are given on the following table.

#### b-Betriebsarten

Die im Katalog angeführten Motoren sind für Betriebsart S1 (Dauerbetrieb) ausgelegt. Andere Betriebsarten sind unten angegeben.

Çalışma Türü Operation Betriebsarten	Açıklama Explanation Erläuterung	Yük Grafiği Load Graphic Lastverläufe
S1	<b>Sabit yükte sürekli çalışma</b> Continuous operation under constant load Dauerbetrieb mit konstanter Belastung	
S2	<b>Sabit yükte kısa süreli çalışma</b> Short-time duty under constant load Kurzbetrieb mit konstanter Belastung	
S3	<b>Yolvermede sıcaklık artımı olmadan periyodik çalışma</b> Periodic duty without influence of start-up on temperature Aussetzbetrieb ohne Einfluß des Anlaufes auf die Temperatur	
S4	<b>Yolvermede sıcaklık artımı olan periyodik çalışma</b> Periodic duty with influence of start up on temperature Aussetzbetrieb mit Einfluß des Anlaufes auf die Temperatur	
S5	<b>Yolvermede ve frenlemede sıcaklık artımlı periyodik çalışma</b> Periodic duty with influence of startup and braking on temp. Aussetzbetrieb mit Einfluß des Anlaufes / Bremsung auf die Temp.	
S6	<b>Sürekli orta darbeleri çalışma</b> Continuous operation with intermittent loading Durchlaufbetrieb mit Aussetzungsbelastung	
S7	<b>Elektriksel frenlemeli sürekli orta darbeleri çalışma</b> Continuous operation with intermittent loading and braking Ununterbrochener Betrieb mit Anlauf und Bremsung	
S8	<b>Devir ve yük değişimli sürekli çalışma</b> Continuous operation duty type with related load-speed changes Ununterbrochener periodischer Betrieb mit Drehzahländerung	



# Genel Bilgiler

## General Information

### Einführung



#### c- Koruma Sınıfı:

Yılmaz Redüktörde standart olarak IP54 (IEC 34-5) koruma sınıfı motorlar kullanılmaktadır. Diğer koruma sınıfları istendiğinde firmamıza danışınız.

#### d- İzolasyon Sınıfı:

Yılmaz Redüktörde kullanılan standart izolasyon sınıfı F (IEC 317-8) dir. İstek üzerine H sınıfı yapılabilmektedir.

#### e- Verim Sınıfları:

Üç fazlı az gerilim asenkron motorların verim sınıfı ölçümü IEC 60034-2-1:2007 normu ile belirlenmiştir. Yeni IE verim sınıfı 0,75 kW'tan 375 kW'a kadar güç aralığında çalışan AC motorlar için geçerlidir. EFF verim sınıfından farklı olarak IE verim sınıfı 6 kutup sayılı motorlar içinde kullanılabilir. Aşağıda verim sınıfları sıralanmıştır. Bölgeler dışında verim sınıfı zorunlulukları ülkelere göre farklılık gösterebilir. Lütfen firmamıza danışınız. Başka ürünlere entegre olmuş ve bu nedenle motorun veriminin bağımsız belirlenemediği sistemlerde (redüktör pompa gibi) verim sınıflandırması geçerli değildir.

#### c- Protection Class:

Yılmaz Redüktör uses IP54 (IEC 34-5) protection class electric motors for standard products. If different kind of protection class is requested please contact us.

#### d- Insulation Class:

Yılmaz Redüktör uses F (IEC 317-8) insulation class electric motors for standard products. H insulation class is available upon request.

#### e- Efficiency Classes:

The method for measuring the efficiency of low voltage three-phase asynchronous motors was revised with the new IEC 60034-2-1:2007 standard. The new IE classes is valid for AC Motors in power range from 0,75 to 375 kW. Unlike the EFF classes IE classes can be used for 6-pole AC motors. Below is the table of efficiency classes. The instructions for efficiency classes can differ from country to country. Please contact with us for more information. For the motors, which are fully integrated into a product (for example gear, pump) so their energy efficiency can not be recognized independently, the requirements of efficiency are not valid in Europe.

#### c- Schutzarten:

Yılmaz Redüktör Getriebemotoren werden serienmäßig mit Schutzart IP54 (IEC34-5) ausgeführt. Für andere Schutzarten bitte rückfragen.

#### d- Isolationsklasse:

Yılmaz Redüktör Getriebemotoren werden serienmäßig in Wärmeklasse F (IEC317-8) ausgeführt. H Wärmeklasse ist möglich auf Kundenwunsch.

#### e- Energieeffizienzklassen:

Die Methode für Messung die Effizienz von drei phasigen gering Spannung Asynchronmotoren hat neu mit IEC 60034-2-1:2007 Norm festgelegt. Die neue IE-Klassen gelten für alle Drehstrommotoren im Leistungsbereich von 0,75 bis 375 kW. Anders als EFF-Klassen die IE-Klassen können auch für 6-polige Drehstrommotoren verwendet werden. Unten steht die Tabelle der Effizienzklassen. Die Richtlinien für Effizienzklassen können sich je nach dem Land unterscheiden. Bitte mit unserem Firma Kontakt aufnehmen. Für die Motoren, die vollständig in ein Produkt (zum Beispiel Getriebe, Pumpe) eingebaut sind und deren Energieeffizienz nicht unabhängig von diesem Produkt erfasst werden kann, gelten in Europa die Anforderungen der Effizienzklassen nicht.

Verim Sınıfları Efficiency Classes Energieeffizienzklassen			4 Kutuplu Motor Verim Değeri Hesabı Calculating Efficiency Values of Motors with 4 Poles Berechnung der Wirkungsgrade von Elektromotoren mit 4 Polen	
IE1	EFF 2	<b>Standart Verim</b> Standart Efficiency Standarte Energieeffizienz	A=0,5234 B=-5,0499 C=17,4180 D=74,3171	$\eta_{Mn} = A \times [\log_{10}(P_L)] + B \times [\log_{10}(P_L)]^2 + C \times \log_{10}(P_L) + D$ <p><math>P_L</math> :Anma Yüğü [kW] / Nominal Load [kW] / Nennlast [kW]</p> <p><math>\eta_{Mn}</math> :Nominal verim / Nominal Efficiency [kW] / Sollwirkungsgrad</p>
IE2	EFF 1	<b>Yüksek Verim</b> High Efficiency Hohe Energieeffizienz	A=0,0278 B=-1,9247 C=10,4395 D=80,9761	
IE3	-	<b>Premium Verim</b> Premium Efficiency Premium Energieeffizienz	A=0,0773 B=-1,8951 C=9,2984 D=83,7025	
IE4	-	<b>Süper Premium Verim</b> Super Premium Efficiency Super Premium Energieeffizienz	-	

4 Kutuplu Motor Verim Değeri Efficiency Values of Motor with 4 poles Sollwirkungsgrad des Motors mit 4 Polen	Anma Yüğü [kW] Nominal Load [kW] Nennlast [kW]	Verim Sınıfı / Efficiency Class / Energieeffizienzklassen		
		IE1	IE2	IE3
	0,75	72,1 %	79,6 %	82,5 %
	1,5	77,2 %	82,8 %	85,3 %
	3	81,5 %	85,5 %	87,7 %
	7,5	86 %	88,7 %	90,4 %
	15	88,7 %	90,6 %	92,1 %
	22	89,9 %	91,6 %	93 %
	37	91,2 %	92,7 %	93,9 %
	45	91,7 %	93,1 %	94,2 %
	75	92,7 %	94 %	95 %
	90	93 %	94,2 %	95,2 %
	330	94 %	95,1 %	96 %



# Genel Bilgiler General Information Einführung



## f- AC Frekans İnvörtörler

Doğru Akımı (DC), alternatif akıma (AC) çeviren elektronik çeviricilere İnvörtör denilmektedir. AC motorlar için elektronik hız kontrol cihazları genellikle AC giriş akımını doğrultucu diyotlarla DC akıma çevirir ve daha sonra çevirici diyotlar vasıtası ile bu akımı tekrar AC akıma çevirir. Doğrultucu diyotlar ile çevirici diyotlar arasındaki bağlantı DC-bağ olarak tanımlanmaktadır. DC kontrol cihazının (genellikle İnvörtör olarak isimlendirilir) elektriksel blok şeması aşağıda verilmiştir.

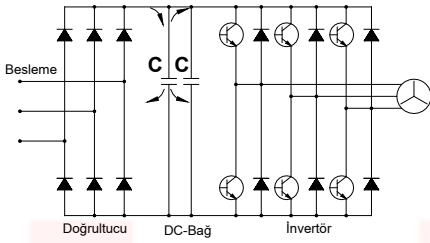

Tam dalga doğrultucuları besleyen üç faz besleme akımı DC-bağ kapasitörlerine iletilir. Kapasitörler voltajdaki dalgalanmaları azaltır ve kısa süreli ağıdaki akım kesintilerinde enerji sağlar. Kapasitörlerdeki voltaj kontrolsüzdür ve gelen AC akımın pik akım değerlerine bağlıdır. DC akım tekrar AC akıma, Puls genişliği modülasyonu (PWM) kullanılarak çevrilir. İstenen dalga formu, sabit bir frekansta (Puls frekansında), çıkış transistörlerinin (İzole edilmiş geçit Bipolar transistörleri; IGBT 'ler) açılıp kapatılması ile oluşturulur. IGBT'lerin açma kapama zamanlarının değişimi ile istenen akım oluşturulabilir. Çıkış voltajı bir seri kare dalga pulslardır ve motor sargılarının İndüktansı ile sinusoidal bir motor akımı oluşur. Puls genişliği modülasyonu aşağıda gösterilmiştir.

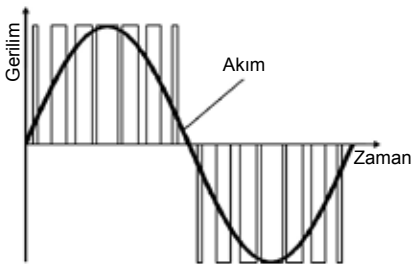

## f- AC Frequency Inverters

An electronic converter is a device which converts Direct Current (DC) to Alternating Current (AC) is known as an inverter. Electronic speed controllers for AC motors usually convert the AC supply to DC using a rectifier, and then convert it back to a variable frequency, variable voltage AC supply using an inverter bridge. The connection between the rectifier and inverter is called the DC link. The block diagram of a speed controller (often called an inverter) is shown below.

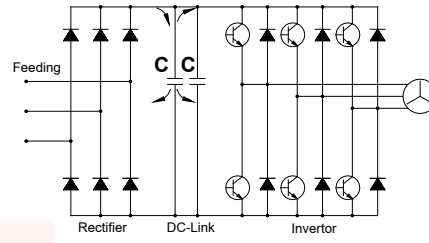

The three phase supply is fed into a full wave rectifier which supplies the DC link capacitors. The capacitors reduce the voltage ripple (especially on single supplies) and supply energy for short mains breaks. The voltage on the capacitors is uncontrolled and depends on the peak AC supply voltage. The DC voltage is converted back to AC using Pulse Width Modulation (PWM). The desired waveform is built up by switching the output transistors (Insulated Gate Bipolar Transistors; IGBTs) on and off at a fixed frequency (the switching frequency). By varying the on and off time of the IGBTs the desired current can be generated. The output voltage is still a series of square wave pulses and the inductance of the motor windings results in a sinusoidal motor current. Pulse Width Modulation is shown in the figure below.

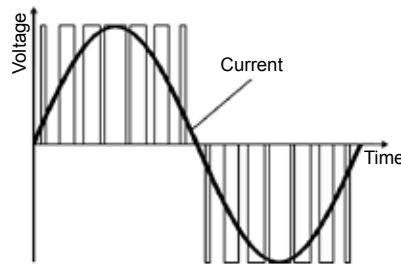

## f- AC Frequenz Umrichter

Ein elektronischer Wandler, der den Gleichstrom (DC) in Wechselstrom (AC) umwandelt, wird als Umrichter bezeichnet. Ein Frequenzumrichter benutzt einen ungesteuerten Eingangsgleichrichter, um die Netzspannung in Gleichspannung umzuwandeln. Diese wird dann in den Zwischenkreiskondensatoren gespeichert. An diesem Gleichspannungszwischenkreis ist ein Wechselrichter angeschlossen. Dieser Wechselrichter erzeugt am Ausgang eine variable Frequenz und eine variable Spannung. Der Anschluss zwischen dem Gleichrichter und dem Wechselrichter nennt man Gleichstromverbindung. Das Blockschaltbild von diesem System wurde unten dargestellt:

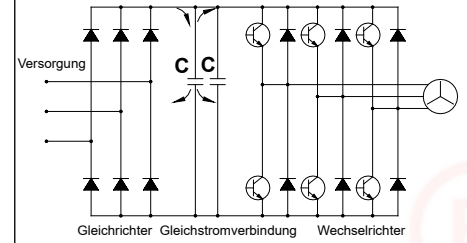

Auch bei dreiphasiger Versorgung wird die gleichrichtete Netzspannung den Zwischenkreiskondensatoren zugeführt. Die Kondensatoren reduzieren die Oberwelligkeit der Spannung (was besonders bei einphasiger Versorgung entscheidend ist) und liefern Energie, die kurze Unterbrechungen der Netzstromversorgung ermöglicht. Die Spannung der Kondensatoren ist vom Spitzenwert der Wechselspannung abhängig. Die Gleichspannung wird im Wechselrichter durch Pulsweitenmodulation (PWM) in Wechselspannung umgewandelt. Die gewünschte Wellenform wird durch Ein- und Ausschalten der Ausgangstransistoren (IGBT's Isolierte Gate Bipolar Transistoren) mit einer festen Frequenz (der Pulsfrequenz) erzeugt. Der gewünschte Strom kann durch die Variation der Ein- und Ausschaltzeit der Ausgangstransistoren generiert werden. Die Ausgangsspannung ist dadurch eine Reihe von Spannungsimpulsen, die in Verbindung mit der Induktivität der Motorspulen zu einem sinusförmigen Motorstrom führt. Die Pulsweitenmodulation wird wie folgt dargestellt

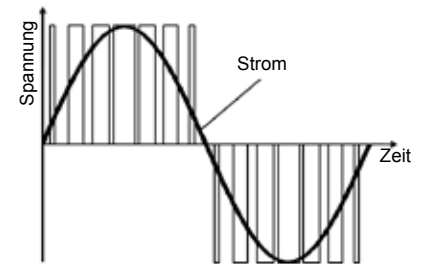



# Genel Bilgiler

## General Information

### Einführung



#### DC MOTORLAR

##### a- Genel Özellikler

DC motorlar, elektronik parçalardaki gelişmeler nedeni ile yeni uygulama alanları bulmuştur. Daha önce çok pahalı olan ve ekonomik olmayan kontrol sistemlerinin yerini ucuz ve kompakt güç kontrol üniteleri almıştır. Yol vermenin kontrol altına alınabildiği, tork ve akım izlenebilirliği, aşırı yüklenmeye karşı elektronik koruma sağlanabilmesi ve daha birçok pahalı olmayan uygulamalar DC motorlarını cazip kılmaya başlamıştır.

##### b- DC Motorların Çalışma İlkeleri

DC motorlar için DC çıkış veren bir doğrultucuya ihtiyaç vardır. Motor armatür sargıları, alan sargıları, komutasyon sargıları ve kompanse sargılar olmak üzere rotorda ve statorda bulunan sargılardan oluşur. Rotora voltaj ve akım karbon fırçalar ve komutator sargılarla ulaştırılır. Bu karbon fırçalar aşındığından DC motorlar belirli periyotlarla bakıma alınmalıdır. İyi kontrol edilebilir özelliklerinden dolayı DC motorlar otomasyon teknolojisinde sıkça kullanılmaktadır.

##### c- DC Motor Çeşitleri

Temel olarak Şönt (Shunt) ve seri sargılı DC motorlar bulunmaktadır. Bu sargıların çeşidine göre moment eğrisi değişmektedir.

##### d- DC Motorlarda Hız Kontrolü

Bu motorlarda devir değişimi DC voltajın değiştirilmesi ile yapılır. Şönt sarımlı DC motorların sıfır yük ile maksimum yük arasındaki davranışı AC motorlara benzer. Devir artan yükte beraber düşer. Bu devir farkı ufak güçlü motorlarda büyük, büyük güçlü motorlarda ise ufaktır. Fakat bu hız farkı DC doğrultucu cihazda armatür voltajı ( $I \times R$ ) ile oynanarak kompanse edilebilir. Hassas hız kontrol gereksinimi olduğunda, tako jeneratörler kullanılabilir. DC motorların gücü aşağıdaki formülden hesaplanır;

$$P_g = U \times I = \frac{P_c}{\eta}$$

$P_g$  : Giriş gücü W  
 $P_c$  : Çıkış gücü W  
 $U$  : Armatür gerilimi V  
 $I$  : Armatür akımı A  
 $\eta$  : Motor verimi

#### DC MOTORS

##### a- General Specifications of DC Motors

*DC drive systems have found new possible applications with the development of the electronic components sector. What was previously extremely expensive and in some cases not economically feasible is nowadays realized by miniaturised power converter technology. Additional functions such as guided startup after a predetermined time, torque and current monitoring with electronic protection against overloading, and many inexpensive special applications have made DC drive systems more attractive.*

##### b- Operating principles of the DC Motors

*The DC motor requires, a converter with DC output. The motor includes windings, such as armature, field, commutation and compensation windings, which are arranged in the stator as well as on rotor. Voltage and current are supplied to the rotor via the carbon brushes and the commutator. The carbon brushes are wearing parts therefore a DC motor requires maintenance at service intervals. While its good control properties, the DC motor is an essential item in automation technology.*

##### c- Types of DC Motors

*Depending on the wiring of the exciting winding or field winding, two basically different variants are regards torque speed characteristics may be distinguished.*

##### d- Speed Control of DC motors

*In DC motors the speed is adjusted by altering the DC voltage. DC shunt wounded motors behave similar to three phase induction motors between no load operation and maximum load. The speed drops with increasing loading of the motor. This difference is greater in small motors and smaller in larger motors. The speed difference can be compensated in the DC converter device by adjusting ( $I \times R$ ). If great control accuracy is required, a speed control with measurement of the actual values by a tachogenerator can be used. The power of DC motor;*

$$P_g = U \times I = \frac{P_c}{\eta}$$

$P_g$  : Input Power W  
 $P_c$  : Output Power W  
 $U$  : Armature Voltage V  
 $I$  : Armature Current A  
 $\eta$  : Motor efficiency

#### DC MOTOREN

##### a- Eigenschaften von DC Motoren

Mit den Entwicklungen bei elektronischen Komponenten haben DC Motoren neue Anwendungsbereiche gefunden. Regelungssysteme, die früher sehr teuer und im manchen Anwendungsfällen ungünstig waren, sind jetzt kompakt und günstig. Bei den DC Motoren ist kontrolliertes Anlauf, Moment- und Stromüberwachung mit Überlastschutz möglich. Es gibt viele günstige Sonderanwendungen für diese Motoren. Wegen oben genannten Eigenschaften werden die DC Motoren immer mehr bei unterschiedlichen Anwendungen benutzt.

##### b- Funktionsprinzip der DC Motoren

Bei DC Motoren ist eine Kommutatorwicklung im Rotor angeordnet, während der magnetische Fluss vom Stator erzeugt wird. Dies kann wiederum mittels einer Erregerwicklung oder durch Permanentmagnete geschehen. Wie bei der Synchronmaschine wird durch das Erregerfeld in der Ankerwicklung eine Wechselfeldspannung, die bei der Gleichstrommaschine jedoch durch den mechanischen Kommutator und die darauf schleifenden Bürsten in eine Gleichspannung umgeformt wird, induziert.

##### c- Arten von DC Motoren

Es gibt zwei verschiedene Wicklungen, nämlich Shunt- und Serial-Wicklung. Das Drehmoment-Drehzahl-Verhältnis ist für beide Wicklungen unterschiedlich.

##### d- Drehzahl Kontrolle für DC Motoren

Drehzahl von DC Motoren kann man mit Steuerung der DC Spannung ändern. DC Motoren mit Shunt Wicklungen ist ähnlich zu drei phasen AC Motoren zwischen maximalen Last und ohne Last. Drehzahl wird mit der Last reduziert. Mit kleineren Motoren wird dieser Differenz höher mit größeren Motoren kleiner. Der Drehzahlunterschied kann geregelt werden mit ( $I \times R$ ) Veränderung. Wenn eine genaue Kontrolle gebraucht, soll ein Tachogenerator benutzt werden. Leistung des DC Motors;

$$P_g = U \times I = \frac{P_c}{\eta}$$

$P_g$  : Eingangsleistung W  
 $P_c$  : Ausgangsleistung W  
 $U$  : Ankerspannung V  
 $I$  : Ankerstrom A  
 $\eta$  : Wirkungsgrad des Motors



# Genel Bilgiler

## General Information

### Einführung



#### Elektromanyetik Frenler

Bu tip frenlerin iki sürtünme yüzeyi vardır. Fren torku, voltaj uygulanmadığı zaman yayların kuvveti ile oluşturulur. Fren elektromanyetik alanın oluşumu ile serbest kalır. Bobinin beslenmesi ile mıknatıslanan balata baskı pulu, elektromıknatısa doğru çekilir. Bu hareket yayları baskı altına alır ve rotor mili üzerine takılan çoklu kama üzerinde aksiyal yönde serbest hareket edebilen balata serbest kalır. Akım kesildiğinde yayların baskısıyla, balata baskı pulu fren balatasına doğru itilir ve bu hareket rotoru frenler.

#### Fren Çeşitleri

##### a) Soğutmasız tip frenler

Motor fanı çıkarılıp motor kapağı arkasına akupile edilerek kullanılan frenler; genellikle sıkça açılıp kapanmayan ve kısa zaman aralıklarında çalışan sistemlerde tercih edilir.

##### b) Soğutmalı tip frenler

Motor fanı çıkarılıp motor kapağı arkasına akupile edilen ve motorun mili uzatılarak fren ve motorun arkasına alınan fan sayesinde daimi bir hava sirkülasyonu sağlanarak kullanılan frenlerdir. Genellikle uzun süreli çalışan ve kapalı mekanlarda kullanılan sistemlerde tercih edilir.

##### c) Manuel kol sistemli frenler

Çalışma sistemi olarak her iki fren tipinde de kullanılabilir (soğutmalı veya soğutmasız). Özel durumlarda (elektrik kesilmesi; mekanik problemler) üzerinde bulunan bir kol vasıtası ile sistemi yay baskısından kurtararak serbest kalmasını sağlayan frenlerdir. Genellikle manuel olarak sistemin açılması gereken yerlerde (otomatik giriş kapıları, dış cepe boyama asansörleri v.b.) tercih edilir.

##### d) Fren çalışma voltajları

Elektromanyetik frenler özel siparişler haricinde 180V DC ve 24V DC olmak üzere 2 ayrı voltaj tipinde üretilir.

##### a) 180 V DC Frenler

Besleme (400 V) motor klemens kutusundan alınarak frenin klemens kutusuna gelmekte ve buradaki yarım dalga doğrultucudan geçerek 180 V DC ye çevrilir ve fren bobini bu voltajla beslenir.

##### b) 24 V DC Frenler

Kullanılan fren momentinin büyüklüğüne göre besleme transformatörü seçilir. Şebekeden veya motorun klemens kutusundan alınan besleme voltajı transformatörde 29 V'a çevrilen gerilim yarım dalga doğrultuculardan geçerek 24V DC'ye çevrilir ve fren bobini beslenir.

##### c) Şok ikazlı trafolar

Büyük güçteki ve momentteki frenlerin manyetik doyuma ulaşmaları uzun zaman alır. Şok ikazlı trafolar frenin yay baskısını yenmede gecikmesini engellemek için kullanılır ve zaman rölesi yardımı ile çok kısa bir süre normal besleme voltajının iki katı ile (48V DC) beslenip sistemin ani açılmasını sağlar. Bu sayede gecikmeli açılımda ortaya çıkacak sürtünmeyi engellemeye yarayan bir trafo şeklidir.

#### Electromagnetic Brakes

*This type of brakes has two friction surfaces. Brake torque is generated by springs when no voltage is applied. The brake is electromagnetically released. On exciting the electromagnet means of the current, the armature plate is pulled towards the electromagnet itself, thrust loading the pressure spring and enabling the friction disc which is axially movable on the key, to turn freely. When current fails, the pressured springs drive the armature plate towards the disc, thus braking the motor shaft.*

#### Brake Types

##### a) Brakes without cooling

*This type of brakes are assembled on the back cover of the electric motor. There is no fan on the backside. This brake type is mostly preferred in short working times and short working cycles.*

##### b) Fan cooled brakes

*This type of brakes are assembled on the back cover of electric motor by removing the electric motor fan. A fan is coupled to the backside of the brake by extending the rotor shaft of the electric motor. Fan cooled brakes are preferred in long working times and closed places without airflow.*

##### c) Brakes with hand release

*This brakes can be released by help of an arm. It can be applied to both of the above mentioned brakes and used in special cases (fail of electric current, mechanical problems etc.) These brakes are mostly preferred if operation (re-lasing) without a current is needed (automatic controlled doors, gates, building wall painting elevators etc.).*

#### d- Working Voltages

*Unless there is no special voltage mentioned by ordering, the electromagnetic brakes are manufactured for working in two voltages either 180 V DC or 24 V DC.*

##### a) 180 V DC Brakes

*The electric supply (400 V) is taken from the terminal box of the electric motor and is transformed to 180V DC with semialternating current transformer.*

##### b) 24 V DC Brakes

*The transformer's size is selected according to value of brake torque. The current is taken from the electric motor terminal box or from the electric panel and is transformed to semi alternating current 24V DC by the help of transformer and a semi alternate current transformer.*

##### c) Shock voltage supply transformer

*Brakes which consist of high power and torques take long time to get in electromagnetic field. Shock voltage supply transformers with time relay are aiming to overcome spring pressure delaying for brakes. Also this transformers provide to open system suddenly by feeding double(48V DC) voltage in a short time and preventing to frictional losses occurring in delayed opening.*

#### Elektromagnetische Bremsen

Die Bremse hat zwei Reibflächen und arbeitet nach dem Ruhestromprinzip. Im stromlosen Zustand wird das Bremsmoment durch den Druck der Feder erzeugt, während die Bremse beim Betrieb elektromagnetisch losgelassen wird. Durch die Erregung der Elektromagneten wird die Ankerscheibe zu den Elektromagneten gezogen und die Feder zusammengedrückt. Dadurch kann sich die Bremscheibe, die axial beweglich auf dem Mitnehmer angeordnet ist, frei drehen. Wird der Strom unterbrochen, drücken die Feder die Ankerscheibe gegen die Bremscheibe und halten die Motorwelle an.

#### Bremsenarten:

##### a) Bremsen ohne Kühlung

Diese Bremsen sind für Kurzlaufzeiten geeignet. Die Lüfterhaube und Lüfter des Motors ist ausgebaut und die Bremse ist an dem Ende der Motorwelle befestigt.

##### b) Bremsen mit Kühlung

Diese Bremsen sind für lange Laufzeiten und kleine, abgedeckte Räume geeignet. Durch die Verlängerung der Motorwelle wurde Lüfter hinter dem Bremse und dem Motor verbunden. Somit wurde eine konstante Lüftung ermöglicht.

##### c) Bremsen mit Hebelarm

Diese Bremsenart kann mit oder ohne Kühlung verwendet werden. Diese Bremsen sind bei der speziellen Fälle, wie keine Spannung an der Leitung, mechanische Probleme usw., anwendbar. Die Bremse wird mit einem Hebelarm manuell betätigt. Diese Bremsen werden am meisten an den Stellen, wo die Lüftung ohne Spannung erfolgen soll, benutzt (automatische Türe, Wandaufzüge).

#### d- Betriebsspannungen

Wenn nichts anderes vorgegeben ist, werden die Bremsen mit 24V DC und 180V DC Versorgungsspannung hergestellt.

##### a) 180 V DC Bremsen

Die Spannung (400 V) wird von den Klemmkasten des Motors entnommen und mit Hilfe von einem Gleichrichter zu 180V DC Gleichstromspannung umgewandelt.

##### b) 24 V DC Bremsen

Die Spannung wird von den Klemmkasten des Motors oder Elektrischschrank entnommen. Diese Spannung wird zuerst mittels Transformator zu 24 V DC reduziert. Dann wird diese Spannung mit Hilfe von Gleichrichter zu Gleichstromspannung umgewandelt. Die Größe des Transformators ist abhängig von der Größe des Bremsmoments.

##### c) Trafos mit Schock-Spannung

Diese Transformatoren werden bei großen Bremsen mit hohen Momenten verwendet. Da die große Bremsen eine lange Zeit braucht, um die erforderliche magnetische Feld zu erzeugen, wird an der Bremse kurz 48 V DC Gleichstromspannung angelegt, um die Zeit zur Bildung von magnetischem Feld zu kürzen. Dies ermöglicht kürzere Reibungszeiten beim Start.



# Genel Bilgiler

## General Information

### Einführung



#### Fren bağlantı şekli

##### a) Gecikmeli frenleme

Genellikle sistemin yavaş ve kaydırılarak durması gereken yerlerde tercih edilen bağlantı şeklidir. Vinç yürütme motorlarındaki sarsıntıyı önlemek için gecikmeli bağlantı şekli kullanılır. Frenler fabrika çıkışında gecikmeli bağlantıya uygun ayarlanır.

##### b) Ani frenleme

Genellikle sistemin enerjisi kesildiği anda ani olarak durdurulması gereken sistemlerde kullanılan bağlantı şeklidir. Vinç kaldırma sistemleri, asansör motorlarında kullanılan bağlantı şeklidir.

#### Connection Types

##### a) Delayed Braking

Generally this type of connection uses in slow and sliding brake intended systems. Delayed connection type using to prevent shock loadings in crane driving systems. Brakes are setting up to delayed connection if any other types are not specified by customer

##### b) Sudden Braking

This type of connections are mostly used in systems when short braking times are needed. The braking torque will be produced as soon as the current fails. These brakes are mostly used in hoisting of lifting units and elevators.

#### Schaltungsarten:

##### a) Verspätetes Bremsen:

Diese Schaltung wird benutzt, wenn ein langsames und gleitendes Bremsen erforderlich ist. Am meisten wird es bei Fahrtriebemotoren von Aufzügen verwendet. Wenn keine Angabe bei der Bestellung gegeben wird, werden die Bremsen mit verspäteter Schaltung geliefert.

##### b) Schnelles Bremsen:

Allgemein verwendet man diese Schaltung bei Bedarf an plötzlichen Bremsen in dem Augenblick, in dem das System keine Energie mehr erhält. Diese Schaltungsart wird meist bei Kräne und Motoren von Aufzügen verwendet.

Gecikmeli Frenleme / Delayed Running Brake / Verspätete Bremsung (220 V)

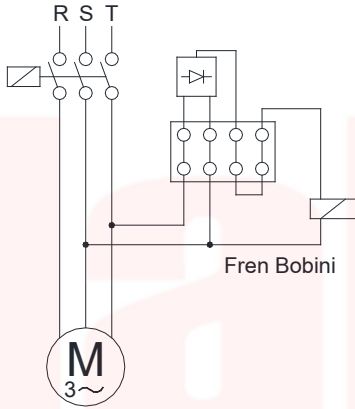

Ani Frenleme / Sudden Brake / Plötzliche Bremsung (220 V)

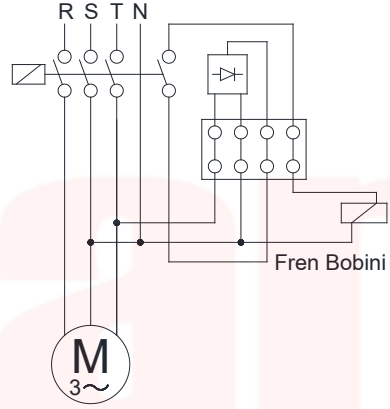

Gecikmeli Frenleme / Delayed Running Brake / Verspätete Bremsung (24 V)

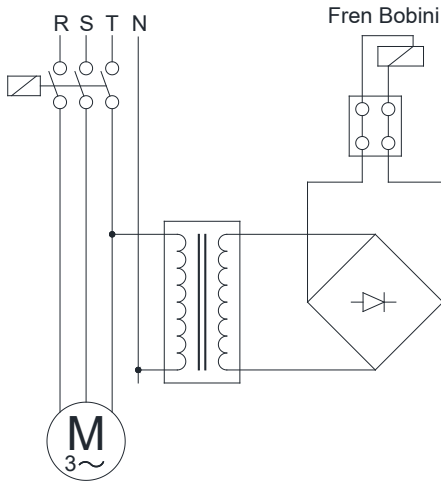

Ani Frenleme / Sudden Brake / Plötzliche Bremsung (24 V)

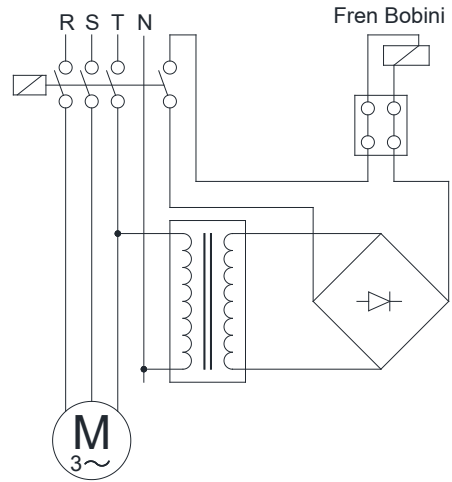



# Genel Bilgiler

## General Information

### Einführung



#### Fren Seçimi:

Doğru bir fren seçimi için aşağıdaki parametreler bilinmelidir.

- $I_{tot}$  [kg.m<sup>2</sup>] : Motor miline indirgenmiş toplam atalet momenti
- $n_0$  [d/dak] : Maksimum motor devir sayısı
- $t_f$  [s] : İstenilen en uzun frenleme zamanı
- $c_t$  : Anahtarın devreye girme zamanı katsayısı (ortalama 0,995).
- $M_L$  [Nm] : Sistemin statik tork ihtiyacı.
- $C_s$  : Emniyet katsayısı ( $C_s \geq 2$  olmalı)

Gerekli fren momenti aşağıdaki şekilde hesaplanır:

a)  $M_L$  Statik yük torku, motor dönüş yönünde (motorun dönüşüne yardımcı olarak, yükün indirilmesi veya hızlandırıcı sabit yük momenti hali):

$$M_{fc} = \frac{(2\pi \times n_0 \div 60) \times I_{tot}}{t_f \times c_t} + M_L$$

b)  $M_L$  Statik yük torku, motor aksi dönüş yönünde (motorun dönüşüne engel olarak, yükün yukarı kaldırılması veya frenleyici sabit yük/direnç momenti hali):

$$M_{fc} = \frac{(2\pi \times n_0 \div 60) \times I_{tot}}{t_f \times c_t} - M_L$$

Yukarıda bulunan sonuç  $C_s$  katsayısı ile çarpılarak ( $C_s \geq 2$ ), fren momenti seçilir;

$$M_f = M_{fc} \times C_s$$

#### Yaklaşım Yolu ile Fren Seçimi:

Eğer yalnızca motorun gücü ve en yüksek devri biliniyor ise :

W [Watt]: Motorun nominal gücü

$$M_f = \frac{W}{\frac{2\pi \times n_0}{60}} \times C_s \quad (C_s \geq 2)$$

#### Standart Frenler / Standard Brakes / Standart Bremsen

<b>Fren statik momenti [Nm]</b> Brake Static Torque [Nm] Statische Bremskraft [Nm]	4,5	8	12	16	35	60	80	150	200
<b>Fren Dinamik Momenti [Nm]</b> Brake Dynamic Torque [Nm] Dynamische Bremskraft [Nm]	3,6	6,4	9,6	12,8	28	48	64	120	160
<b>Maksimum Motor Hızı [d/dak]</b> Maximum Motor Speed [rpm] Maximale Motordrehzahl [U/min]	3000	3000	3000	3000	3000	3000	3000	1500	1500
<b>Giriş Gücü [W]</b> Input Power [W] Antriebsleistung [W]	15	20	25	30	45	50	55	60	65

#### Brake Selection:

To select a brake correctly the following data are necessary;

- $I_{tot}$  [kg . m<sup>2</sup>] : The total inertia of rotating parts reduced at the motor shaft
- $n_0$  [rpm] : Maximum motor speed.
- $t_f$  [s] : The maximum admitted time of the braking.
- $c_t$  : Coefficient of switch on time (average 0,995).
- $M_L$  [Nm] : Required static torque of system.
- $C_s$  : Safety coefficient ( $C_s \geq 2$ )

The necessary braking torque calculates below;

a) The static load torque  $M_L$ , same direction of motor rotation (Descent of a load or steady resisting torque which favours the rotation of the motor)

$$M_{fc} = \frac{(2\pi \times n_0 \div 60) \times I_{tot}}{t_f \times c_t} + M_L$$

b) The static load torque  $M_L$ , opposes the rotation of the motor (Lifting of a load or steady resisting torque which opposes the rotation of the motor)

$$M_{fc} = \frac{(2\pi \times n_0 \div 60) \times I_{tot}}{t_f \times c_t} - M_L$$

The necessary braking torque will result from the following equation using  $C_s$  ( $C_s \geq 2$ );

$$M_f = M_{fc} \times C_s$$

#### Approximated Brake Selection

Its only the motor power and its maximum speed are known:

W [Watt]: Motor Nominal Power

$$M_f = \frac{W}{\frac{2\pi \times n_0}{60}} \times C_s \quad (C_s \geq 2)$$

#### Bremswahl:

Um die richtige Bremse auszuwählen, braucht man unten aufgelistete Variablen;

- $I_{tot}$  [kg . m<sup>2</sup>] : Die Gesamtträgheit der rotierenden Teile (siehe Anwendungsbeispiele)
- $n_0$  [U/min] : Die höchste Drehzahl des Motors
- $t_f$  [s] : Die längste zulässige Bremszeit
- $c_t$  : Reduktionskoeffizient der Tätigkeitszeit (gemittelt 0,995).
- $M_L$  [Nm] : Vom system benötigtes, statisches Drehmoment.
- $C_s$  : Sicherheitskoeffizient ( $C_s \geq 2$ )

Die benötigte Bremskraft wird wie folgt berechnet:

a) konstantes Belastungsmoment  $M_L$ , das die Motordrehung fördert (konstante Erhöhung der Motorgeschwindigkeit oder Herunterlassen der Last)

$$M_{fc} = \frac{(2\pi \times n_0 \div 60) \times I_{tot}}{t_f \times c_t} + M_L$$

b) konstantes Belastungsmoment  $M_L$ , das sich entgegen der Motordrehung widersetzt (konstante Verminderung der Motorgeschwindigkeit oder Aufheben der Last)

$$M_{fc} = \frac{(2\pi \times n_0 \div 60) \times I_{tot}}{t_f \times c_t} - M_L$$

Wenn die Bremskraft mit dem Sicherheitskoeffizient  $C_s$  ( $C_s \geq 2$ ) multipliziert wird, erhält man die erforderliche Bremskraft;

$$M_f = M_{fc} \times C_s$$

#### Abschätzung zur Bremswahl

Wenn man nur die Motorleistung und die höchste Drehzahl kennt, kann die Bremskraft mit der folgenden Formel annähernd berechnet werden:  
W [Watt] : Nennleistung des Motors

$$M_f = \frac{W}{\frac{2\pi \times n_0}{60}} \times C_s \quad (C_s \geq 2)$$

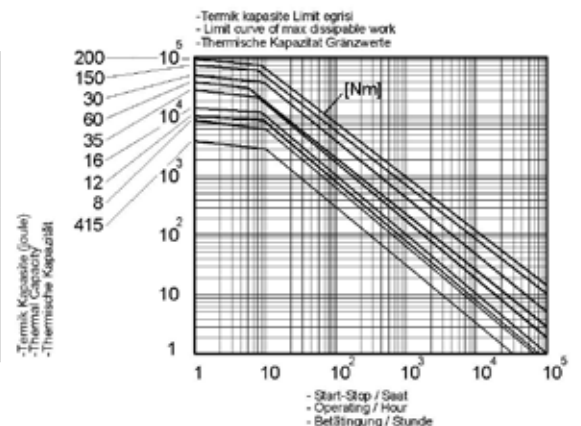



# Genel Bilgiler

## General Information

### Einführung



#### Frenin Termik Kapasitesi

Yukarıdaki seçime ek olarak frenin termik kapasitesinin kontrol edilmesi gerekir. L (joule) olarak gerekli soğutma işi aşağıdaki formüller ile hesaplanır ve "Termik kapasite limit eğrisi" kullanılarak eğrinin altında kalıp kalmadığı kontrol edilir.

a)  $M_L$  Statik yük torku motor dönüş yönünde (motorun dönüşüne yardımcı olarak, yükün indirilmesi hali)

$$L = \frac{I_{tot} \times (2\pi \times n_0 \div 60)^2}{2} \times \left( \frac{M_f}{M_f - M_L} \right)$$

b)  $M_L$  Statik yük torku motor aksi dönüş yönünde (motorun dönüşüne engel olarak, yükün kaldırılması hali):

$$L = \frac{I_{tot} \times (2\pi \times n_0 \div 60)^2}{2} \times \frac{M_f}{M_f + M_L}$$

c)  $M_L$  Statik yük torku sabit, motor yönünde veya aksi yönde (kaldırma ve indirme harici hızlandırıcı veya frenleyici sabit bir yük momenti hali).

$$L = \frac{I_{tot} \times (2\pi \times n_0 \div 60)^2}{2}$$

#### Fren Hava Boşluğunun Ayarı:

Frenden sürekli aynı performansın alınabilmesi için, fren balatasının aşınmasına bağlı olarak, fren hava boşluğu belirli zaman aralıklarında yeniden ayarlanmalıdır. Fren hava boşluğu ayar zaman aralığı ve ayarın yapılması için firmamıza danışınız.

#### Fren Seçim Örneği:

İstenilen en uzun frenleme zamanı: 0,5 sn.  
Motor devri: 1400 d/dak  
Motora indirgenmiş toplam atalet momenti: 0,08 kgm<sup>2</sup>

Gerekli çalışma momenti: 50 Nm

Yük Durumu: Yük motor dönüş yönü ile aynı (Vinçten yük indirilmesi: Saatte dur-kalk sayısı:30)

$$M_{fc} = \frac{(2\pi \times 1400 \div 60)}{0,5 \times 0,995} + 50 = 73,6 \text{ Nm}$$

$$M_f = 73,6 \times 2 = 147,2 \text{ Nm}$$

Standart frenler tablosundan 150 Nm lik fren seçilebilir.

Gerekli termik kapasite:

$$L = \frac{0,08 \times (2\pi \times 1400 \div 60)^2}{2} \times \left( \frac{147,2}{147,2 - 50} \right)$$

=1302,0 < 18000 Joule (150 Nm eğrisinden)  
150 Nm lik fren uygun görülüyor.

#### The Thermal Capacity of Brake

The thermal capacity of the brake must also be checked after the above mentioned calculations. The heat dissipation energy L (joule) can be calculated from the following equation and must be checked if the result is under the limit curve shown on "Limit curve of may dissipable work".

a) The static load torque  $M_L$ , favours the rotation of the motor (Descent of a load which favours the rotation of the motor)

$$L = \frac{I_{tot} \times (2\pi \times n_0 \div 60)^2}{2} \times \left( \frac{M_f}{M_f - M_L} \right)$$

b) The static load torque  $M_L$ , opposes the rotation of the motor (Lifting of a load which opposes the rotation of the motor)

$$L = \frac{I_{tot} \times (2\pi \times n_0 \div 60)^2}{2} \times \frac{M_f}{M_f + M_L}$$

c) The static load torque  $M_L$ , is constant and opposes or favours the rotation of the motor (except lifting of a load)

$$L = \frac{I_{tot} \times (2\pi \times n_0 \div 60)^2}{2}$$

#### Adjustment of the air-gap:

In order to obtain the same performance from the brake during its lifetime, the air-gap of the brake must be re-adjusted after a limited time of operation. For the air-gap and the time interval of the adjustment please contact us.

#### Selection Example:

The maximum admitted time for braking 0,5 s  
Motor speed: 1400 rpm  
Total inertia reduced at motor shaft: 0,08 kgm<sup>2</sup>

Required operating torque: 50 Nm

Nature of load: Load direction is same as motor direction (Unloading process: Start-stop time per hour :30)

$$M_{fc} = \frac{(2\pi \times 1400 \div 60)}{0,5 \times 0,995} + 50 = 73,6 \text{ Nm}$$

$$M_f = 73,6 \times 2 = 147,2 \text{ Nm}$$

From the brake selection table a standard brake of 150 Nm is selected.

Necessary thermal capacity

$$L = \frac{0,08 \times (2\pi \times 1400 \div 60)^2}{2} \times \left( \frac{147,2}{147,2 - 50} \right)$$

=1302,0 < 18000 Joule (from 150 Nm curve)  
The selected brake with 150 Nm is suitable.

#### Thermische Kapazität der Bremsen

Nach den oben genannten Berechnungen muss die Thermische Kapazität überprüft werden. Die Wärme, d.h. die gebrauchte Energie L, werden mit den folgenden Formeln berechnet. Die gerechnete Kapazitätswerte sollen unter dem Grenzkurve "Thermische Kapazität Grenzwerte" der gewählten Bremse liegen.

a) Konstantes Belastungsmoment  $M_L$ , das die Motordrehung fördert (Herunterlassen der Last)

$$L = \frac{I_{tot} \times (2\pi \times n_0 \div 60)^2}{2} \times \left( \frac{M_f}{M_f - M_L} \right)$$

b) Konstantes Belastungsmoment  $M_L$ , das sich entgegen der Motordrehung widersetzt (Aufheben der Last)

$$L = \frac{I_{tot} \times (2\pi \times n_0 \div 60)^2}{2} \times \frac{M_f}{M_f + M_L}$$

c) Konstantes Belastungsmoment  $M_L$ , das sich gegen der Motorbewegung widersetzt oder die Motorrotation fördert (Konstante Verminderung oder Erhöhung der Motorgeschwindigkeit, kein Herunterlassen oder Aufheben der Last)

$$L = \frac{I_{tot} \times (2\pi \times n_0 \div 60)^2}{2}$$

#### Einstellung des Luftspaltes:

Um eine immer konstant bleibende Bremsfähigkeit zu erhalten, muss das Luftspalt nach einer bestimmten Arbeitszeit neu eingestellt werden. Für die Bestimmung des Luftspaltes und die Einstellzeiten bitten wir Sie um Rückfrage.

#### Beispiel für eine Auswahl:

Die höchste zulässige Bremszeit: 0,5 s  
Motordrehzahl: 1400 U/min  
Gesamtträgheit der rotierenden Teile: 0,08 kgm<sup>2</sup>  
Das auf das System wirkende Drehmoment: 50 Nm  
Belastungsart: Drehmoment, das die Motorrotation fördert (Herunterlassen der Last)  
Betätigungen pro Stunde:30

$$M_{fc} = \frac{(2\pi \times 1400 \div 60)}{0,5 \times 0,995} + 50 = 73,6 \text{ Nm}$$

$$M_f = 73,6 \times 2 = 147,2 \text{ Nm}$$

Eine Bremse von 150 Nm kann man auswählen.

Die thermische Kapazität:

$$L = \frac{0,08 \times (2\pi \times 1400 \div 60)^2}{2} \times \left( \frac{147,2}{147,2 - 50} \right)$$

=1302,0 < 18000 Joule (von 150 Nm Kurve) Die ausgewählte 150 Nm Bremse ist ausreichend.





# Güç ve Devir Tabloları

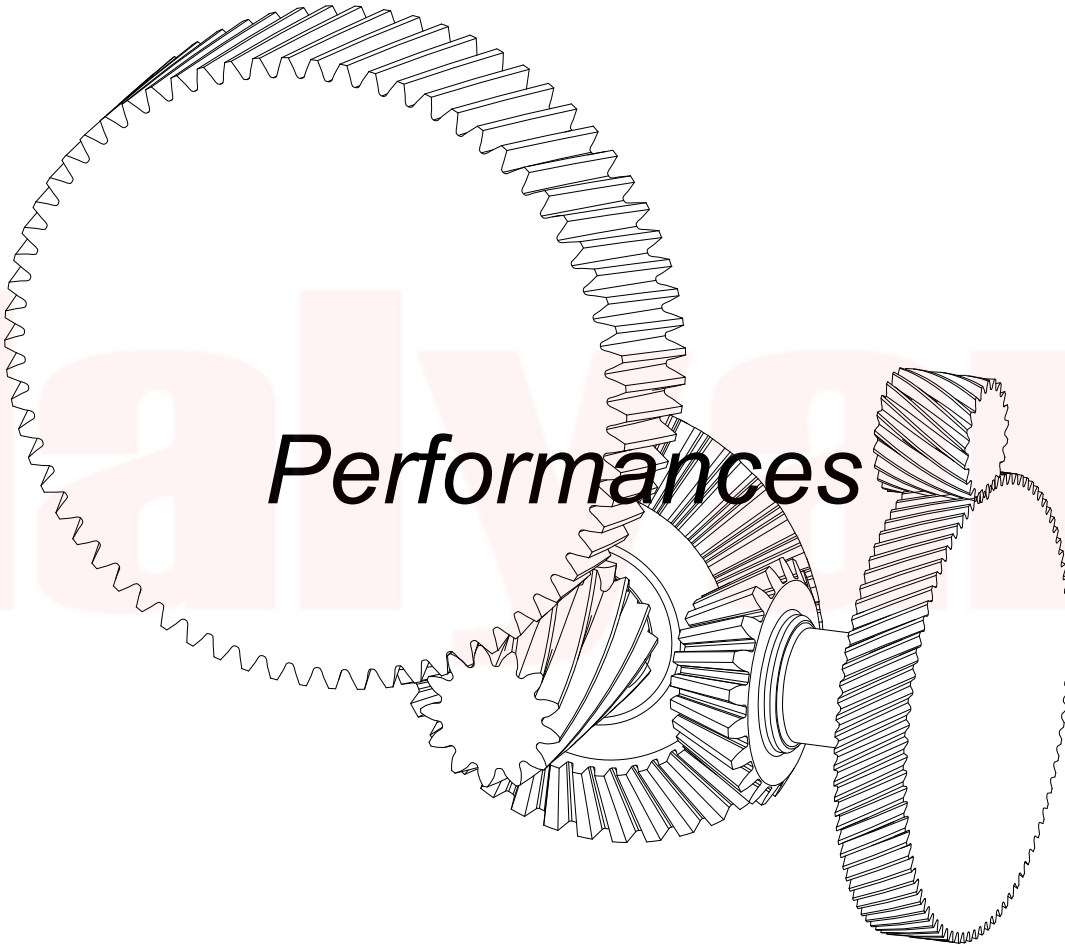

## Leistung und Drehzahlübersicht



# K Serisi Motorlu Güç Devir Sayfaları

## K Series Geared Motors Performance Tables

### K Serien Getriebemotoren Leistung und Drehzahlübersicht



Güç	Çıkış Devri	Çıkış Momenti	Çevrim Oranı	Güv. Rad. Yük Çıkış	Servis Faktörü	Tipi	Anma Akımı	Ağırlık	Ölçü Sayfası	Fiyat Kodu
Power	Output Speeds	Output Torque	Ratio	Per.O. Loads (Output)	Service Factors	Type	Rated Current	Weight	Dim. Page	Price Ref.
Leistung P <sub>g</sub> [kW] P <sub>g</sub> [HP]	Abtriebswelle Drehzahlen n <sub>2</sub> [r.p.m]	Abtriebswelle Drehmomente M <sub>2</sub> [Nm]	Übersetzung i	Zul.Querkräfte (Abtrieb) F <sub>qam</sub> [N]	Betriebsfaktor f <sub>s</sub>	Typ	Nennstrom [A]	Gewicht ~ [kg]	Maße Seite	Preis No.
0,12 0,18	0.21	4179	6611.61	0	0.6	KR576-63/4a	0,41	156	120	KR001
	0.25	3535	5587.93	9748	0.8					
	0.35	2560	4047.32	24010	1.1					
	0.39	2277	3597.31	26480	1.2					
	0.51	1747	2755.47	30240	1.5					
	0.60	1478	2328.84	31839	1.8					
0.63	1447	2236.28	32013	32013	1.9	KR575-63/4a	0,41	151	120	KR002
	0.74	1224	1890.04	33217	2.2					
	1.02	887	1368.95	34789	3.0					
0.49	1825	2873.07	13584	13584	0.8	KR476-63/4a	0,41	113	108	KR003
	0.53	1696	2663.91	15125	0.9					
	0.56	1588	2495.47	16249	1.0					
	0.64	1392	2183.54	17982	1.1					
0.79	1144	1767.90	19850	19850	1.4	KR475-63/4a	0,41	109	108	KR004
	0.95	957	1476.60	21035	1.6					
	1.0	904	1395.04	21342	1.7					
	1.1	791	1218.61	21975	2.0					
	1.2	743	1142.99	22193	2.1					
	1.4	632	971.77	22775	2.5					
	1.6	587	901.03	22985	2.6					
	1.7	550	844.06	23155	2.8					
0.82	1077	1699.70	8023	8023	0.8	KR376-63/4a	0,41	68	96	KR005
	0.93	953	1500.87	10240	0.9					
	1.0	891	1401.91	11141	0.9					
	1.2	753	1184.90	12814	1.1					
1.3	709	1094.97	13298	13298	1.2	KR375-63/4a	0,41	64	96	KR006
	1.4	628	968.01	14079	1.3					
	1.7	528	814.20	14948	1.6					
	2.0	450	692.22	15540	1.8					
	2.4	385	593.11	15995	2.1					
	2.6	349	536.75	16225	2.4					
	3.0	309	473.96	16497	2.7					
	3.2	289	442.71	16597	2.8					
1.6	559	881.79	11261	11261	0.8	KR276-63/4a	0,41	30	84	KR007
	1.9	467	735.42	11955	1.0					
1.9	467	719.79	11953	11953	1.0	KR275-63/4a	0,41	29	84	KR008
	2.1	438	675.13	12142	1.0					
	2.4	372	573.99	12551	1.2					
	2.8	324	498.55	12822	1.4					
	3.2	283	436.24	13025	1.6					
	3.9	235	360.73	13251	1.9					
	4.7	196	300.85	13434	2.3					
	5.6	164	252.20	13566	2.7					
	6.5	141	215.91	13659	3.2					
	7.0	131	200.35	13683	3.4					
	10.6	86	131.68	13856	4.0					
12.3	76.51	113.65	13890	13890	4.0	KR273-63/4a	0,41	20	80	KR227
	14.5	65.16	96.68	13928	4.0					
	16.8	56.32	83.48	13956	4.0					
	19.2	49.24	72.92	13979	4.0					



# K Serisi Motorlu Güç Devir Sayfaları

## K Series Geared Motors Performance Tables

### K Serien Getriebemotoren Leistung und Drehzahlübersicht



Güç	Çıkış Devri	Çıkış Momenti	Çevrim Oranı	Güv. Rad. Yük Çıkış	Servis Faktörü	Tipi	Anma Akımı	Ağırlık	Ölçü Sayfası	Fiyat Kodu
Power	Output Speeds	Output Torque	Ratio	Per.O. Loads (Output)	Service Factors	Type	Rated Current	Weight	Dim. Page	Price Ref.
Leistung P <sub>g</sub> [kW] P <sub>g</sub> [HP]	Abtriebswelle Drehzahlen n <sub>2</sub> [r.p.m]	Abtriebswelle Drehmomente M <sub>2</sub> [Nm]	Übersetzung i	Zul.Querkräfte (Abtrieb) F <sub>qam</sub> [N]	Betriebsfaktor f <sub>s</sub>	Typ	Nennstrom [A]	Gewicht ~ [kg]	Maße Seite	Preis No.
0,12 0,18	20.5	46.20	<b>68.40</b>	13989	4.0	<b>KR273-63/4a</b>	0,41	20	80	KR227
	24.1	39.27	<b>58.15</b>	14010	4.0					
	27.7	34.13	<b>50.51</b>	14027	4.0					
	31.7	29.88	<b>44.20</b>	14040	4.0					
	38.3	24.72	<b>36.55</b>	14056	4.0					
	45.9	20.63	<b>30.48</b>	14068	4.0					
	54.8	17.29	<b>25.55</b>	14150	4.0					
	60.7	15.65	<b>23.08</b>	14195	4.0					
	73.4	12.94	<b>19.08</b>	14253	4.0					
	88.0	10.79	<b>15.92</b>	14305	4.0					
	104.9	9.03	<b>13.34</b>	14354	4.0					
	116.7	8.08	<b>12.00</b>	14537	4.0					
	141.1	6.67	<b>9.92</b>	14165	4.0					
	169.2	5.55	<b>8.28</b>	13422	4.0					
201.8	4.64	<b>6.94</b>	12737	4.0						
0,18 0,25	0.11	12428	<b>7938.12</b>	94659	1.2	<b>KR876-71/6a</b>	0,61	644	156	KR009
	0.13	11003	<b>7017.76</b>	100297	1.4					
	0.15	9273	<b>5902.70</b>	106729	1.6					
	0.18	7898	<b>5018.35</b>	111162	1.9					
	0.21	6779	<b>4299.81</b>	114488	2.2					
	0.23	6142	<b>3891.23</b>	116267	2.4					
	0.26	5366	<b>3396.71</b>	118321	2.8					
	0.30	4737	<b>2996.39</b>	119954	3.2					
	0.34	4217	<b>2665.68</b>	121165	3.6					
	0.38	3780	<b>2387.89</b>	122196	4.0					
	0.43	3281	<b>2074.42</b>	123375	4.0					
	0.39	3604	<b>3597.31</b>	7639	0.7					
	0.51	2766	<b>2755.47</b>	21967	1.0					
	0.60	2340	<b>2328.84</b>	25955	1.2					
	0.63	2291	<b>2236.28</b>	26363	1.2	<b>KR575-63/4b</b>	0,60	152	120	KR011
	0.74	1938	<b>1890.04</b>	29009	1.4					
	1.0	1404	<b>1368.95</b>	32301	1.9					
	1.2	1248	<b>1216.74</b>	33070	2.2					
	1.5	959	<b>932.00</b>	34457	2.8					
	1.8	812	<b>787.70</b>	35097	3.3					
	0.79	1812	<b>1767.90</b>	13800	0.9	<b>KR475-63/4b</b>	0,60	110	108	KR012
	0.95	1515	<b>1476.60</b>	16919	1.0					
	1.0	1432	<b>1395.04</b>	17652	1.1					
	1.1	1253	<b>1218.61</b>	19066	1.2					
1.2	1176	<b>1142.99</b>	19617	1.3						
1.4	1000	<b>971.77</b>	20767	1.5						
1.6	929	<b>901.03</b>	21199	1.7						
1.7	870	<b>844.06</b>	21557	1.8						
1.9	777	<b>472.63</b>	22032	2.0	<b>KR474-71/6a</b>	0,61	98	104	KR013	
2.1	695	<b>422.88</b>	22449	2.2						
2.4	611	<b>371.35</b>	22851	2.5						
2.9	511	<b>310.16</b>	23301	3.0						
3.1	483	<b>293.03</b>	23456	3.2						
1.3	1123	<b>1094.97</b>	6953	0.7	<b>KR375-63/4b</b>	0,60	70	96	KR014	
1.4	994	<b>968.01</b>	9575	0.8						
1.7	837	<b>814.20</b>	11846	1.0						
2.0	712	<b>692.22</b>	13265	1.2						
2.4	610	<b>593.11</b>	14238	1.3						



# K Serisi Motorlu Güç Devir Sayfaları

## K Series Geared Motors Performance Tables

### K Serien Getriebemotoren Leistung und Drehzahlübersicht



Güç	Çıkış Devri	Çıkış Momenti	Çevrim Oranı	Güv. Rad. Yük Çıkış	Servis Faktörü	Tipi	Anma Akımı	Ağırlık	Ölçü Sayfası	Fiyat Kodu					
Power	Output Speeds	Output Torque	Ratio	Per.O. Loads (Output)	Service Factors	Type	Rated Current	Weight	Dim. Page	Price Ref.					
Leistung P <sub>g</sub> [kW] P <sub>g</sub> [HP]	Abtriebswelle Drehzahlen n <sub>2</sub> [r.p.m]	Abtriebswelle Drehmomente M <sub>2</sub> [Nm]	Übersetzung i	Zul.Querkräfte (Abtrieb) F <sub>qam</sub> [N]	Betriebsfaktor f <sub>s</sub>	Typ	Nennstrom [A]	Gewicht ~ [kg]	Maße Seite	Preis No.					
0,18 0,25	2.4	604	367.43	14278	1.4	KR374-71/6a	0,61	60	92	KR015					
	3.0	486	295.76	15262	1.7										
	3.5	427	259.36	15695	1.9										
	3.8	388	367.43	15965	2.1	KR374-63/4b	0,60	59	92	KR016					
	4.7	313	295.76	16444	2.6										
	5.4	274	259.36	16666	3.0										
	2.4	589	573.99	11013	0.8	KR275-63/4b	0,60	29	84	KR017					
	2.8	512	498.55	11626	0.9										
	3.2	449	436.24	12072	1.0										
	3.9	371	360.73	12546	1.2										
	4.7	310	300.85	12878	1.5										
	5.6	260	252.20	13141	1.7										
	6.5	223	215.91	13314	2.0										
	7.0	207	200.35	13385	2.2										
	7.9	190	113.65	13452	2.4	KR273-71/6a	0,61	21	80	KR018					
9.3	162	96.68	13566	2.8											
11	140	83.48	13649	3.2											
12	122	113.65	13715	3.7	KR273-63/4b	21	80	KR228							
14	104	96.68	13795	4.0											
17	90	83.48	13844	4.0											
19	78	72.92	13883	4.0											
20	74	68.40	13899	4.0											
24	63	58.15	13936	4.0											
28	54	50.51	13963	4.0											
32	48	44.20	13985	4.0											
38	39	36.55	14011	4.0											
46	33	30.48	14031	4.0											
55	28	25.55	14106	4.0											
61	25	23.08	14169	4.0											
73	21	19.08	14232	4.0											
88	17	15.92	14290	4.0											
105	14	13.34	14342	4.0											
117	13	12.00	14530	4.0											
141	11	9.92	14130	4.0											
169	9	8.28	13393	4.0											
202	7	6.94	12712	4.0											
0,25 0,34	0.15	12900	9052.24	92529	1.2	KR876-71/4a	0,61	646	156	KR019					
	0.18	11330	7938.12	99220	1.3										
	0.20	10031	7017.76	104090	1.5										
	0.24	8454	5902.70	109411	1.8										
	0.28	7201	5018.35	113257	2.1										
	0.33	6180	4299.81	116157	2.4										
	0.36	5599	3891.23	117714	2.7										
	0.41	4892	3396.71	119644	3.1										
	0.47	4319	2996.39	120946	3.5										
	0.53	3845	2665.68	122163	3.9										
	0.59	3446	2387.89	122934	4.0										
	0.20	10178	7156.22	38854	0.8						KR776-71/4a	0,81	390	144	KR020
	0.22	9079	6380.72	47778	0.9										
	0.25	7996	5610.63	54772	1.0										
	0.31	6444	4516.30	62939	1.2										
0.35	5660	3960.44	66228	1.4											
0.40	5012	3501.26	68794	1.6											



# K Serisi Motorlu Güç Devir Sayfaları

## K Series Geared Motors Performance Tables

### K Serien Getriebemotoren Leistung und Drehzahlübersicht



Güç	Çıkış Devri	Çıkış Momenti	Çevrim Oranı	Güv. Rad. Yük Çıkış	Servis Faktörü	Tipi	Anma Akımı	Ağırlık	Ölçü Sayfası	Fiyat Kodu
Power	Output Speeds	Output Torque	Ratio	Per.O. Loads (Output)	Service Factors	Type	Rated Current	Weight	Dim. Page	Price Ref.
Leistung P <sub>g</sub> [kW] P <sub>g</sub> [HP]	Abtriebswelle Drehzahlen n <sub>2</sub> [r.p.m]	Abtriebswelle Drehmomente M <sub>2</sub> [Nm]	Übersetzung i	Zul.Querkräfte (Abtrieb) F <sub>qam</sub> [N]	Betriebsfaktor f <sub>s</sub>	Typ	Nennstrom [A]	Gewicht ~ [kg]	Maße Seite	Preis No.
0,25 0,34	0.44	4690	<b>3203.12</b>	70062	1.7	<b>KR775-71/4a</b>	0,81	390	144	KR021
	0.49	4155	<b>2838.16</b>	71888	1.9					
	0.55	3720	<b>2539.01</b>	73301	2.2					
	0.68	3035	<b>2066.04</b>	75398	2.6					
	0.78	2620	<b>1786.65</b>	76571	3.1					
	0.36	5475	<b>3844.04</b>	10354	0.8	<b>KR676-71/4a</b>	0,81	316	132	KR022
	0.41	4847	<b>3398.35</b>	22218	0.9					
	0.49	4085	<b>2858.39</b>	30366	1.1					
	0.58	3480	<b>2430.14</b>	35155	1.2					
	0.67	2987	<b>2082.19</b>	38434	1.4					
	0.75	2746	<b>1875.03</b>	39846	1.6	<b>KR675-71/4a</b>	0,81	314	120	KR023
	0.88	2335	<b>1597.25</b>	42037	1.8					
	1.0	2010	<b>1373.07</b>	43655	2.1					
	1.2	1746	<b>1191.60</b>	44795	2.5					
	1.3	1527	<b>1041.68</b>	45771	2.8					
1.5	1343	<b>915.75</b>	46442	3.2						
0.63	3248	<b>2236.28</b>	15721	0.8	<b>KR575-71/4a</b>	0,81	154	120	KR024	
0.74	2748	<b>1890.04</b>	22192	1.0						
1.0	1991	<b>1368.95</b>	28627	1.4						
1.2	1770	<b>1216.74</b>	30138	1.5						
1.5	1360	<b>932.00</b>	32506	2.0						
1.8	1151	<b>787.70</b>	33550	2.3						
1.9	1096	<b>469.74</b>	33805	2.5	<b>KR574-71/6b</b>	0,83	162	116	KR025	
2.3	927	<b>397.01</b>	34574	2.9						
1.0	2030	<b>1395.04</b>	10695	0.8	<b>KR475-71/4a</b>	0,81	111	108	KR026	
1.1	1776	<b>1218.61</b>	14231	0.9						
1.2	1667	<b>1142.99</b>	15434	0.9						
1.4	1418	<b>971.77</b>	17787	1.1						
1.6	1318	<b>901.03</b>	18580	1.2						
1.7	1234	<b>844.06</b>	19201	1.3						
1.9	1103	<b>472.63</b>	20113	1.4	<b>KR474-71/6b</b>	0,61	116	104	KR027	
2.1	986	<b>422.88</b>	20850	1.6						
2.4	867	<b>371.35</b>	21545	1.8						
3.0	709	<b>472.63</b>	22383	2.2	<b>KR474-71/4a</b>	0,81	96	104	KR028	
3.3	634	<b>422.88</b>	22746	2.4						
3.8	557	<b>371.35</b>	23098	2.8						
4.5	466	<b>310.16</b>	23530	3.3						
2.0	1009	<b>692.22</b>	9346	0.8	<b>KR375-71/4a</b>	0,81	70	96	KR029	
2.4	865	<b>593.11</b>	11511	0.9						
2.4	856	<b>367.43</b>	11607	1.0	<b>KR374-71/6b</b>	0,83	62	92	KR030	
3.0	690	<b>295.76</b>	13487	1.2						
3.5	605	<b>259.36</b>	14299	1.4						
3.8	550	<b>367.43</b>	14758	1.5	<b>KR374-71/4a</b>	0,81	62	92	KR031	
4.7	443	<b>295.76</b>	15579	1.8						
5.4	389	<b>259.36</b>	15953	2.1						



# K Serisi Motorlu Güç Devir Sayfaları

## K Series Geared Motors Performance Tables

### K Serien Getriebemotoren Leistung und Drehzahlübersicht



Güç	Çıkış Devri	Çıkış Momenti	Çevrim Oranı	Güv. Rad. Yük Çıkış	Servis Faktörü	Tipi	Anma Akımı	Ağırlık	Ölçü Sayfası	Fiyat Kodu	
Power	Output Speeds	Output Torque	Ratio	Per.O. Loads (Output)	Service Factors	Type	Rated Current	Weight	Dim. Page	Price Ref.	
Leistung P <sub>g</sub> [kW] P <sub>g</sub> [HP]	Abtriebswelle Drehzahlen n <sub>2</sub> [r.p.m]	Abtriebswelle Drehmomente M <sub>2</sub> [Nm]	Übersetzung i	Zul.Querkräfte (Abtrieb) F <sub>qam</sub> [N]	Betriebsfaktor f <sub>s</sub>	Typ	Nennstrom [A]	Gewicht ~ [kg]	Maße Seite	Preis No.	
0,25 0,34	6.1	354	148.75	16200	2.3	KR373-71/6b	0,83	57	90	KR032	
	7.1	303	127.30	16507	2.7						
	8.1	264	110.61	16745	3.1						
	3.9	527	360.73	11505	0.9	KR275-71/4a	0,81	32	84	KR033	
		4.7	440	300.85	12124						1.0
		5.6	369	252.20	12552						1.2
		6.5	316	215.91	12852						1.4
		7.0	294	200.35	12972						1.5
	7.9	270	113.65	13103	1.7	KR273-71/6b	0,83	22	80	KR034	
		9.3	230	96.68	13279						2.0
		11	199	83.48	13421						2.3
	12	174	113.65	13533	2.6	KR273-71/4a	0,81	23	80	KR035	
		14	148	96.68	13625						3.0
		17	128	83.48	13706						3.5
		19	112	72.92	13766						4.0
20		105	68.40	13791	4.0						
24		89	58.15	13855	4.0						
28		78	50.51	13889	4.0						
32		68	44.20	13919	4.0						
38		56	36.55	13958	4.0						
46		47	30.48	13990	4.0						
55		39	25.55	14075	4.0						
61		36	23.08	14141	4.0						
73	30	19.08	14221	4.0							
88	25	15.92	14274	4.0							
105	21	13.34	14335	4.0							
0,37 0,50	0.24	12899	5902.70	92531	1.2	KR876-71/4b	1,15	646	156	KR036	
	0.28	10986	5018.35	100551	1.4						
	0.33	9429	4299.81	106215	1.6						
	0.36	8543	3891.23	109166	1.8						
	0.41	7464	3396.71	112666	2.0						
	0.47	6590	2996.39	115092	2.3						
	0.53	5866	2665.68	117025	2.6						
	0.59	5258	2387.89	118644	2.9						
	0.67	4564	2074.42	120365	3.3						
	0.74	4239	1891.08	121100	3.5	KR875-71/4b	1,15	644	156	KR037	
		0.84	3752	1671.18	122215						4.0
		0.94	3358	1495.27	123073						4.0
	0.31	9832	4516.30	41784	0.8	KR776-71/4b	1,15	388	144	KR038	
		0.35	8636	3960.44	50902						0.9
		0.40	7646	3501.26	56756						1.0
0.44	7155	3203.12	59387	1.1	KR775-71/4b	1,15	386	144	KR039		
	0.49	6340	2838.16	63320						1.3	
	0.55	5675	2539.01	66183						1.4	
	0.68	4631	2066.04	70229						1.7	
	0.78	3997	1786.65	72415						2.0	
	0.90	3465	1547.01	74091						2.3	
	1.0	3033	1353.02	75375						2.6	
	1.2	2676	1192.77	76371						3.0	



# K Serisi Motorlu Güç Devir Sayfaları

## K Series Geared Motors Performance Tables

### K Serien Getriebemotoren Leistung und Drehzahlübersicht



Güç	Çıkış Devri	Çıkış Momenti	Çevrim Oranı	Güv. Rad. Yük Çıkış	Servis Faktörü	Tipi	Anma Akımı	Ağırlık	Ölçü Sayfası	Fiyat Kodu
Power	Output Speeds	Output Torque	Ratio	Per.O. Loads (Output)	Service Factors	Type	Rated Current	Weight	Dim. Page	Price Ref.
Leistung P <sub>g</sub> [kW] P <sub>g</sub> [HP]	Abtriebswelle Drehzahlen n <sub>2</sub> [r.p.m]	Abtriebswelle Drehmomente M <sub>2</sub> [Nm]	Übersetzung i	Zul.Querkräfte (Abtrieb) F <sub>qam</sub> [N]	Betriebsfaktor f <sub>s</sub>	Typ	Nennstrom [A]	Gewicht ~ [kg]	Maße Seite f	Preis No.
0.37 0.50	0.58	5309	2430.14	14518	0.8	KR676-71/4b	1,15	228	132	KR040
	0.67	4557	2082.19	25704	0.9					
0.75 0.88 1.0 1.2 1.3 1.5 1.7 1.9 2.2	0.75	4190	1875.03	29457	1.0	KR675-71/4b	1,15	245	132	KR041
	0.88	3563	1597.25	34566	1.2					
	1.0	3066	1373.07	37921	1.4					
	1.2	2663	1191.60	40327	1.6					
	1.3	2330	1041.68	42055	1.8					
	1.5	2050	915.75	43465	2.1					
	1.7	1815	809.27	44489	2.4					
	1.9	1624	724.08	45302	2.6					
2.2	1429	635.86	46089	3.0						
1.0 1.2 1.5 1.8	1.0	3037	1368.95	18825	0.9	KR575-71/4b	1,15	154	120	KR042
	1.2	2701	1216.74	22600	1.0					
	1.5	2076	932.00	28025	1.3					
	1.8	1756	787.70	30194	1.5					
1.9 2.3 2.7	1.9	1672	469.74	30703	1.6	KR574-80/6a	1,1	159	116	KR043
	2.3	1415	397.01	32180	1.9					
	2.7	1174	328.56	33425	2.3					
3.0 3.5	3.0	1075	469.74	33903	2.5	KR574-71/4b	1,15	151	116	KR044
	3.5	910	397.01	34652	3.0					
1.9 2.1 2.4	1.9	1682	472.63	15277	0.9	KR474-80/6a	1,1	98	104	KR045
	2.1	1505	422.88	17013	1.0					
	2.4	1323	371.35	18554	1.2					
3.0 3.3 3.8 4.5 4.8	3.0	1081	472.63	20251	1.4	KR474-71/4b	1,15	96	104	KR046
	3.3	967	422.88	20964	1.6					
	3.8	850	371.35	21636	1.8					
	4.5	711	310.16	22369	2.2					
	4.8	672	293.03	22563	2.3					
5.9 6.6 8.1	5.9	558	153.47	23177	2.8	KR473-80/6a	1,1	91	100	KR047
	6.6	494	135.98	23440	3.1					
	8.1	403	110.65	23809	3.8					
3.0 3.5	3.0	1052	295.76	8519	0.8	KR374-80/6a	1,1	64	92	KR048
	3.5	924	259.36	10673	0.9					
3.8 4.7 5.4 6.1	3.8	840	367.43	11812	1.0	KR374-71/4b	1,15	62	92	KR049
	4.7	676	295.76	13621	1.2					
	5.4	594	259.36	14382	1.4					
	6.1	525	229.29	14954	1.6					
7.1 8.1	7.1	462	127.30	15458	1.8	KR373-80/6a	1,1	60	88	KR050
	8.1	402	110.61	15879	2.0					
9.4 11 13	9.4	348	148.75	16242	2.4	KR373-71/4b	1,15	58	88	KR051
	11	298	127.30	16546	2.8					
	13	259	110.61	16776	3.2					



# K Serisi Motorlu Güç Devir Sayfaları

## K Series Geared Motors Performance Tables

### K Serien Getriebemotoren Leistung und Drehzahlübersicht



Güç	Çıkış Devri	Çıkış Momenti	Çevrim Oranı	Güv. Rad. Yük Çıkış	Servis Faktörü	Tipi	Anma Akımı	Ağırlık	Ölçü Sayfası	Fiyat Kodu
Power	Output Speeds	Output Torque	Ratio	Per.O. Loads (Output)	Service Factors	Type	Rated Current	Weight	Dim. Page	Price Ref.
Leistung P <sub>g</sub> [kW] P <sub>g</sub> [HP]	Abtriebswelle Drehzahlen n <sub>2</sub> [r.p.m]	Abtriebswelle Drehmomente M <sub>2</sub> [Nm]	Übersetzung i	Zul.Querkräfte (Abtrieb) F <sub>qam</sub> [N]	Betriebsfaktor f <sub>s</sub>	Typ	Nennstrom [A]	Gewicht ~ [kg]	Maße Seite	Preis No.
0.37 0,50	4.7	671	300.85	10276	0.7	KR275-71/4b	1,15	32	84	KR052
	5.6	563	252.20	11244	0.8					
	6.5	483	215.91	11844	0.9					
	7.0	449	200.35	12067	1.0					
	9.3	351	96.68	12650	1.3	KR273-80/6a	1,1	35	80	KR053
	11	303	83.48	12923	1.5					
	12	266	113.65	13113	1.7	KR273-71/4b	1,15	24	80	KR054
	14	226	96.68	13296	2.0					
	17	196	83.48	13429	2.3					
	19	171	72.92	13530	2.6					
	20	161	68.40	13571	2.8					
	24	137	58.15	13662	3.3					
	28	119	50.51	13726	3.8					
	32	104	44.20	13794	4.0					
	38	86	36.55	13857	4.0					
	46	72	30.48	13905	4.0					
	55	60	25.55	14007	4.0					
	61	55	23.08	14085	4.0					
	73	45	19.08	14167	4.0					
88	38	15.92	14239	4.0						
105	32	13.34	14303	4.0						
117	28	12.00	14506	4.0						
141	23	9.92	14018	4.0						
169	20	8.28	13300	4.0						
202	16	6.94	12634	4.0						
0.55 0.75	0.41	11095	3396.71	100240	1.4	KR876-80/4a	1,1	652	148	KR055
	0.47	9795	2996.39	105018	1.5					
	0.53	8720	2665.68	108622	1.7					
	0.59	7816	2387.89	111455	1.9					
	0.67	6784	2074.42	114492	2.2					
	0.74	6301	1891.08	115874	2.4	KR875-80/4a	1,1	648	148	KR056
	0.84	5578	1671.18	117767	2.7					
	0.94	4992	1495.27	119246	3.0					
	1.1	4391	1313.07	120680	3.4					
	1.3	3676	1096.71	122279	4.1					
	1.5	3213	957.34	123454	4.7					
	0.44	10636	3203.12	34128	0.8	KR775-80/4a	1,1	390	144	KR057
	0.49	9424	2838.16	45311	0.8					
	0.55	8436	2539.01	52216	0.9					
	0.68	6884	2066.04	60727	1.2					
	0.78	5942	1786.65	65067	1.3					
	0.90	5150	1547.01	68285	1.6					
	1.0	4508	1353.02	70633	1.8					
	1.2	3978	1192.77	72440	2.0					
1.3	3531	1058.16	73857	2.3						
1.5	3150	943.49	74993	2.5						
1.7	2789	833.78	76015	2.9						
1.9	2496	746.01	76918	3.2						
0.88	5297	1597.25	14881	0.8	KR675-80/4a	1,1	247	132	KR058	
1.0	4558	1373.07	25741	0.9						
1.2	3959	1191.60	31458	1.1						
1.3	3464	1041.68	35315	1.2						
1.5	3047	915.75	38041	1.4						
1.7	2697	809.27	40111	1.6						





# K Serisi Motorlu Güç Devir Sayfaları

## K Series Geared Motors Performance Tables

### K Serien Getriebemotoren Leistung und Drehzahlübersicht



Güç	Çıkış Devri	Çıkış Momenti	Çevrim Oranı	Güv. Rad. Yük Çıkış	Servis Faktörü	Tipi	Anma Akımı	Ağırlık	Ölçü Sayfası	Fiyat Kodu
Power	Output Speeds	Output Torque	Ratio	Per.O. Loads (Output)	Service Factors	Type	Rated Current	Weight	Dim. Page	Price Ref.
Leistung P <sub>g</sub> [kW] P <sub>g</sub> [HP]	Abtriebswelle Drehzahlen n <sub>2</sub> [r.p.m]	Abtriebswelle Drehmomente M <sub>2</sub> [Nm]	Übersetzung i	Zul.Querkräfte (Abtrieb) F <sub>qam</sub> [N]	Betriebsfaktor f <sub>s</sub>	Typ	Nennstrom [A]	Gewicht ~ [kg]	Maße Seite	Preis No.
0.55 0.78	1.9	2414	724.08	41693	1.8	KR675-80/4a	1,1	317	132	KR058
	2.2	2124	635.86	43065	2.0					
	2.5	1939	363.81	43918	2.2	KR674-80/6b	1,5	204	128	KR059
	2.8	1717	321.51	44897	2.5					
	3.3	1461	273.88	45969	2.9					
	3.8	1257	235.44	46774	3.4					
	1.5	3085	932.00	18145	0.9	KR575-80/4a	1,1	152	120	KR060
	1.8	2611	787.70	23541	1.0					
	1.9	2485	469.74	24708	1.1	KR574-80/6b	1,5	155	116	KR061
	2.3	2103	397.01	27837	1.3					
	2.7	1745	328.56	30251	1.5					
	3.0	1598	469.74	31147	1.7	KR574-80/4a	1,1	152	116	KR062
	3.5	1352	397.01	32517	2.0					
	4.3	1122	328.56	33679	2.4					
	5.0	960	281.00	34445	2.8					
	5.7	843	246.42	34969	3.2					
2.4	1966	371.35	11705	0.8	KR474-80/6b	1,5	100	106	KR063	
	3.0	1608	472.63	16042	1.0	KR474-80/4a	1,1	98	106	KR064
	3.3	1438	422.88	17603	1.1					
	3.8	1264	371.35	19018	1.2					
	4.5	1057	310.16	20407	1.5					
	4.8	999	293.03	20770	1.6					
	5.9	831	153.47	21838	1.9	KR473-80/6b	1,5	92	100	KR065
	6.6	736	135.98	22314	2.1					
	8.1	600	110.65	22954	2.6					
	9.1	535	153.47	23280	2.9	KR473-80/4a	1,6	91	100	KR066
	10	474	135.98	23531	3.3					
	13	386	110.65	23881	4.0					
	4.7	1005	295.76	9356	0.8	KR374-80/4a	1,6	64	92	KR067
	5.4	883	259.36	11251	0.9					
	6.1	781	229.29	12512	1.0					
	7.1	688	127.30	13553	1.2	KR373-80/6b	1,5	62	88	KR068
	8.1	599	110.61	14370	1.4					
	9.3	527	97.26	16830	1.6					
	11	443	127.30	15607	1.9	KR373-80/4a	1,6	60	88	KR069
	13	386	110.61	16002	2.1					
	14	339	97.26	16299	2.4					
	18	273	78.29	16696	3.0					
7.0	667	200.35	10316	0.7	KR275-80/4a	1,5	35	84	KR070	
9.3	523	96.68	11531	0.9	KR273-80/6b	1,5	26	84	KR071	



# K Serisi Motorlu Güç Devir Sayfaları

## K Series Geared Motors Performance Tables

### K Serien Getriebemotoren Leistung und Drehzahlübersicht



Güç	Çıkış Devri	Çıkış Momenti	Çevrim Oranı	Güv. Rad. Yük Çıkış	Servis Faktörü	Tipi	Anma Akımı	Ağırlık	Ölçü Sayfası	Fiyat Kodu	
Power	Output Speeds	Output Torque	Ratio	Per.O. Loads (Output)	Service Factors	Type	Rated Current	Weight	Dim. Page	Price Ref.	
Leistung P <sub>g</sub> [kW] P <sub>g</sub> [HP]	Abtriebswelle Drehzahlen n <sub>2</sub> [r.p.m]	Abtriebswelle Drehmomente M <sub>2</sub> [Nm]	Übersetzung i	Zul.Querkräfte (Abtrieb) F <sub>qam</sub> [N]	Betriebsfaktor f <sub>s</sub>	Typ	Nennstrom [A]	Gewicht ~ [kg]	Maße Seite	Preis No.	
0.55 0.75	11	452	83.48	12043	1.0	KR273-80/6b	1,5	26	80	KR071	
	12	395	72.92	12399	1.1						
0.75 1.0	14	337	96.68	12745	1.3	KR273-80/4a	1,6	27	80	KR072	
	17	291	83.48	12986	1.5						
	19	255	72.92	13166	1.8						
	20	239	68.40	13239	1.9						
	24	203	58.15	13397	2.2						
	28	177	50.51	13507	2.5						
	32	155	44.20	13594	2.9						
	38	128	36.55	13693	3.5						
	46	107	30.48	13783	4.0						
	55	90	25.55	13912	4.0						
	61	81	23.08	14004	4.0						
	73	67	19.08	14106	4.0						
	88	56	15.92	14192	4.0						
	105	47	13.34	14265	4.0						
	117	42	12.00	14483	4.0						
	141	35	9.92	13912	4.0						
	169	29	8.28	13211	4.0						
202	24	6.94	12560	4.0							
0.75 1.0	0.47	13357	2996.39	90499	1.1	KR876-80/4b	2,0	650	148	KR073	
	0.53	11891	2665.68	96965	1.3						
	0.59	10658	2387.89	101819	1.4						
	0.67	9251	2074.42	106925	1.6						
	0.74	8593	1891.08	109015	1.7	KR875-80/4b	2,0	648	148	KR074	
		0.84	7606	1671.18	112150						2.0
		0.94	6807	1495.27	114417						2.2
		1.1	5988	1313.07	116660						2.5
		1.3	5013	1096.71	119136						3.0
		1.5	4381	957.34	120635						3.4
		1.7	3868	844.51	121974						3.9
		1.9	3445	751.30	122940						4.0
	0.68	9387	2066.04	45517	0.9	KR775-80/4b	2,0	390	144	KR076	
		0.78	8103	1786.65	54213						1.0
		0.90	7023	1547.01	60051						1.1
		0.67	9563	1353.02	44132						0.8
		1.2	5424	1192.77	67308						1.5
		1.3	4815	1058.16	69520						1.7
		1.5	4296	943.49	71358						1.9
		1.7	3803	833.78	72985						2.1
1.9		3404	746.01	74223	2.4						
2.1		2995	655.11	75424	2.7						
2.3	2889	396.00	75799	2.8	KR774-90S/6	2,1	403	140	KR077		
	2.5	2585	354.32	76663						3.1	
	2.9	2274	311.14	77510						3.5	
1.2	5399	1191.60	12692	0.8	KR675-80/4b	2,0	318	140	KR078		
	1.3	4723	1041.68	23802						0.9	
	1.5	4155	915.75	29712						1.0	
	1.7	3678	809.27	33713						1.2	
	1.9	3292	724.08	36460						1.3	
	2.2	2896	635.86	38983						1.5	
2.5	2644	363.81	40390	1.6	KR674-90S/6	2,1	297	136	KR079		



# K Serisi Motorlu Güç Devir Sayfaları

## K Series Geared Motors Performance Tables

### K Serien Getriebemotoren Leistung und Drehzahlübersicht



Güç	Çıkış Devri	Çıkış Momenti	Çevrim Oranı	Güv. Rad. Yük Çıkış	Servis Faktörü	Tipi	Anma Akımı	Ağırlık	Ölçü Sayfası	Fiyat Kodu					
Power	Output Speeds	Output Torque	Ratio	Per.O. Loads (Output)	Service Factors	Type	Rated Current	Weight	Dim. Page	Price Ref.					
Leistung P <sub>g</sub> [kW] P <sub>g</sub> [HP]	Abtriebswelle Drehzahlen n <sub>2</sub> [r.p.m]	Abtriebswelle Drehmomente M <sub>2</sub> [Nm]	Übersetzung i	Zul.Querkräfte (Abtrieb) F <sub>qam</sub> [N]	Betriebsfaktor f <sub>s</sub>	Typ	Nennstrom [A]	Gewicht ~ [kg]	Maße Seite	Preis No.					
0.75 1.0	2.8	2341	321.51	41994	1.8	KR674-90S/6	2,0	297	128	KR079					
	3.3	1992	273.88	43684	2.2										
	3.9	1700	363.81	44967	2.5	KR674-80/4b	2,0	293	128	KR080					
	4.4	1505	321.51	45780	2.9										
	5.1	1280	273.88	46681	3.4										
	1.9	3389	469.74	13357	0.8	KR574-90S/6	2,1	155	116	KR081					
	2.3	2868	397.01	20842	0.9										
	2.7	2380	328.56	25633	1.1										
	3.0	2179	469.74	27261	1.2	KR574-80/4b	2,0	153	116	KR082					
	3.5	1844	397.01	29618	1.5										
	4.3	1530	328.56	31540	1.8										
	5.0	1309	281.00	32748	2.1										
	5.7	1150	246.42	33557	2.3										
	5.9	1109	237.97	33756	2.4										
	6.6	987	211.51	34333	2.7										
	6.6	987	211.51	34333	2.7										
	3.3	1961	422.88	11790	0.8	KR474-80/4b	2,0	100	104	KR084					
	3.8	1724	371.35	14829	0.9										
	4.5	1442	310.16	17575	1.1										
	4.8	1362	293.03	18241	1.1										
	5.9	1133	153.47	20034	1.4	KR473-90S/6	2,1	95	100	KR085					
	6.6	1003	135.98	20831	1.5										
	8.1	818	119.65	21864	1.9										
	9.1	731	153.47	22362	2.1	KR473-80/4b	2,0	92	100	KR086					
	10	647	135.98	22755	2.4										
	13	528	110.65	23289	2.9										
	14	467	97.79	23564	3.3										
	6.1	1065	229.29	8243	0.8	KR374-80/4b	2,0	65	94	KR087					
	8.1	816	110.61	12158	1.0										
	9.3	718	97.26	16200	1.1	KR373-90S/6	2,1	64	88	KR088					
	11	605	127.30	14339	1.4										
	13	527	110.61	14985	1.6	KR373-80/4b	2,0	61	88	KR089					
	14	463	97.26	15461	1.8										
	18	373	78.29	16101	2.2										
	20	328	68.65	16380	2.5										
	23	290	60.69	16602	2.8										
	11	616	83.48	10783	0.7						KR273-90S/6	2,1	27	80	KR090
	12	539	72.92	11416	0.8										
	15	460	96.68	11992	1.0	KR273-80/4b	2,0	28	80	KR091					
	17	398	83.48	12386	1.1										
	19	348	72.92	12668	1.3										
	21	326	68.40	12802	1.4										
	24	277	58.15	13055	1.6										
	28	241	50.51	13228	1.9										
	32	211	44.20	13362	2.1										
	38	175	36.55	13514	2.6										
	46	146	30.48	13627	3.1										



# K Serisi Motorlu Güç Devir Sayfaları

## K Series Geared Motors Performance Tables

### K Serien Getriebemotoren Leistung und Drehzahlübersicht



Güç	Çıkış Devri	Çıkış Momenti	Çevrim Oranı	Güv. Rad. Yük Çıkış	Servis Faktörü	Tipi	Anma Akımı	Ağırlık	Ölçü Sayfası	Fiyat Kodu					
Power	Output Speeds	Output Torque	Ratio	Per.O. Loads (Output)	Service Factors	Type	Rated Current	Weight	Dim. Page	Price Ref.					
Leistung P <sub>g</sub> [kW] P <sub>g</sub> [HP]	Abtriebswelle Drehzahlen n <sub>2</sub> [r.p.m]	Abtriebswelle Drehmomente M <sub>2</sub> [Nm]	Übersetzung i	Zul.Querkräfte (Abtrieb) F <sub>qam</sub> [N]	Betriebsfaktor f <sub>s</sub>	Typ	Nennstrom [A]	Gewicht ~ [kg]	Maße Seite	Preis No.					
0.75 1.0	55	123	25.55	13799	3.5	KR273-80/4b	2,0	28	80	KR091					
	61	111	23.08	13908	3.7										
	73	92	19.08	14033	4.0										
	88	77	15.92	14135	4.0										
	105	65	13.34	14222	4.0										
	117	58	12.00	14456	4.0										
	141	48	9.92	13795	4.0										
	169	40	8.28	13113	4.0										
	202	34	6.94	12478	4.0										
	210	32	13.34	14409	4.0						KR273-80/2a	1,8	29	80	KR092
	233	29	12.00	14538	4.0										
	282	24	9.92	13795	4.0										
	338	20	8.28	13113	4.0										
	404	17	6.94	12478	4.0										
1.1 1.5	0.74	12603	1891.08	94084	1.2	KR875-90S/4	2,6	652	156	KR093					
	0.84	11155	1671.18	99924	1.3										
	0.94	9983	1495.27	104294	1.5										
	1.1	8782	1313.07	108577	1.7										
	1.3	7352	1096.71	112817	2.0										
	1.5	6425	957.34	115438	2.3										
	1.7	5674	844.51	117428	2.6										
	1.9	5052	751.30	118989	3.0										
	2.1	4686	438.70	88709	3.2						KR874-90L/6	2,7	645	152	KR094
	2.3	4110	383.99	90572	3.6										
	2.7	3642	339.70	92130	4.0										
	0.9	10301	1547.01	37673	0.8	KR775-90S/4	2,6	394	144	KR096					
	1.0	9017	1353.02	48196	0.9										
	1.2	7955	1192.77	55013	1.0										
	1.3	7062	1058.16	59852	1.1										
	1.5	6301	943.49	63565	1.3										
	1.7	5578	833.78	66563	1.4										
	1.9	4992	746.01	68852	1.6										
	2.1	4392	655.11	71017	1.8										
	2.3	4237	396.00	71573	1.9	KR774-90L/6	3,0	344	140	KR097					
	2.5	3792	354.32	73057	2.1										
	2.9	3336	311.14	74491	2.4										
	3.2	2988	278.35	75616	2.7										
	3.5	2724	396.00	76275	2.9	KR774-90S/4	2,6	365	140	KR098					
	4.0	2438	354.32	77070	3.3										
	1.7	5395	809.27	12748	0.8	KR675-90S/4	2,6	252	140	KR099					
	1.9	4828	724.08	22352	0.9										
	2.2	4248	635.86	28869	1.0										
	2.5	3879	363.81	32128	1.1	KR674-90L/6	3,0	267	128	KR100					
	2.8	3433	321.51	35505	1.3										
3.3	2921	273.88	38803	1.5											
3.9	2493	363.81	41205	1.7	KR674-90S/4	2,6	265	128	KR101						
4.4	2207	321.51	42659	1.9											
5.1	1878	273.88	44206	2.3											



# K Serisi Motorlu Güç Devir Sayfaları

## K Series Geared Motors Performance Tables

### K Serien Getriebemotoren Leistung und Drehzahlübersicht



Güç	Çıkış Devri	Çıkış Momenti	Çevrim Oranı	Güv. Rad. Yük Çıkış	Servis Faktörü	Tipi	Anma Akımı	Ağırlık	Ölçü Sayfası	Fiyat Kodu
Power	Output Speeds	Output Torque	Ratio	Per.O. Loads (Output)	Service Factors	Type	Rated Current	Weight	Dim. Page	Price Ref.
Leistung P <sub>g</sub> [KW] P <sub>g</sub> [HP]	Abtriebswelle Drehzahlen n <sub>2</sub> [r.p.m]	Abtriebswelle Drehmomente M <sub>2</sub> [Nm]	Übersetzung i	Zul.Querkräfte (Abtrieb) F <sub>qam</sub> [N]	Betriebsfaktor f <sub>s</sub>	Typ	Nennstrom [A]	Gewicht ~ [kg]	Maße Seite	Preis No.
1.1 1.5	6.0	1617	<b>235.44</b>	45341	2.7	<b>KR674-90S/4</b>	2,6	265	128	KR101
	6.9	1405	<b>204.32</b>	46205	3.1					
	3.0	3195	<b>469.74</b>	16549	0.8	<b>KR574-90S/4</b>	2,6	154	116	KR102
	3.5	2704	<b>397.01</b>	22613	1.0					
	4.3	2244	<b>328.56</b>	26756	1.2					
	5.0	1920	<b>281.00</b>	29110	1.4					
	5.7	1687	<b>246.42</b>	30614	1.6					
	5.9	1627	<b>237.97</b>	30976	1.7					
	6.7	1447	<b>211.51</b>	32059	1.9					
	7.7	1239	<b>180.90</b>	33143	2.2					
	8.8	1088	<b>158.64</b>	33871	2.5					
	10	964	<b>140.24</b>	34445	2.8					
	12	813	<b>117.96</b>	35107	3.3					
	5.9	1664	<b>153.47</b>	15735	0.9	<b>KR473-90L/6</b>	3,0	98	100	KR103
	6.6	1474	<b>135.98</b>	17461	1.1					
	8.1	1202	<b>110.65</b>	19524	1.3					
	9.1	1072	<b>153.47</b>	20444	1.4	<b>KR473-90S/4</b>	2,6	96	100	KR104
	10	950	<b>135.98</b>	21166	1.6					
	13	775	<b>110.65</b>	22110	2.0					
	14	685	<b>97.79</b>	22573	2.3					
	16	613	<b>87.49</b>	22899	2.5					
	18	539	<b>76.83</b>	23251	2.9					
	22	451	<b>64.17</b>	23612	3.4					
		8.1	1199	<b>110.61</b>	4985					
9.2		1055	<b>97.26</b>	8585	0.8					
12		850	<b>78.29</b>	11723	1.0					
	13	773	<b>110.61</b>	12699	1.1	<b>KR373-90S/4</b>	2,6	65	88	KR106
	14	680	<b>97.26</b>	13655	1.2					
	18	548	<b>78.29</b>	14817	1.5					
	20	481	<b>68.65</b>	15331	1.7					
	23	426	<b>60.69</b>	15726	1.9					
	27	359	<b>51.05</b>	16173	2.3					
	32	305	<b>43.40</b>	16514	2.7					
	38	262	<b>37.19</b>	16759	3.1					
		17	583	<b>83.48</b>	11082					
19		510	<b>72.92</b>	11637	0.9					
20		479	<b>68.40</b>	11862	0.9					
24		407	<b>58.15</b>	12328	1.1					
28		354	<b>50.51</b>	12633	1.3					
32		310	<b>44.20</b>	12888	1.5					
38		257	<b>36.55</b>	13155	1.8					
46		215	<b>30.48</b>	13348	2.1					
55		180	<b>25.55</b>	13573	2.4					
61		163	<b>23.08</b>	13711	2.5					
73		135	<b>19.08</b>	13895	2.9					
88		113	<b>15.92</b>	14030	3.3					
105		95	<b>13.34</b>	14141	3.7					
117		85	<b>12.00</b>	14289	2.9					
141	70	<b>9.92</b>	13589	3.4						
169	59	<b>8.28</b>	12942	3.9						
202	49	<b>6.94</b>	12334	4.0						
210	47	<b>13.34</b>	14378	6.3	<b>KR273-80/2b</b>	2,4	26	80	KR108	



# K Serisi Motorlu Güç Devir Sayfaları

## K Series Geared Motors Performance Tables

### K Serien Getriebemotoren Leistung und Drehzahlübersicht



Güç	Çıkış Devri	Çıkış Momenti	Çevrim Oranı	Güv. Rad. Yük Çıkış	Servis Faktörü	Tipi	Anma Akımı	Ağırlık	Ölçü Sayfası	Fiyat Kodu
Power	Output Speeds	Output Torque	Ratio	Per.O. Loads (Output)	Service Factors	Type	Rated Current	Weight	Dim. Page	Price Ref.
Leistung P <sub>g</sub> [kW] P <sub>g</sub> [HP]	Abtriebswelle Drehzahlen n <sub>2</sub> [r.p.m]	Abtriebswelle Drehmomente M <sub>2</sub> [Nm]	Übersetzung i	Zul.Querkräfte (Abtrieb) F <sub>qam</sub> [N]	Betriebsfaktor f <sub>s</sub>	Typ	Nennstrom [A]	Gewicht ~ [kg]	Maße Seite	Preis No.
1.1 1.5	233 282 338 404	42 35 29 25	12.00 9.92 8.28 6.94	14289 13589 12942 12334	4.0 4.0 4.0 4.0	KR273-80/2b	2,4	26	80	KR108
1.5 2.0	0.94 1.1 1.3 1.5 1.7 1.9	13614 11976 10026 8762 7737 6889	1495.27 1313.07 1096.71 957.34 844.51 751.30	89316 96588 99692 103733 106807 109174	1.1 1.3 1.5 1.7 1.9 2.2	KR875-90L/4	3,5	654	156	KR109
	2.1 2.3 2.6	6391 5605 4967	438.70 383.99 339.70	110488 112542 114124	2.3 2.7 3.0	KR874-100L/6	3,5	891	152	KR110
	1.3 1.5 1.7 1.9 2.1	9630 8592 7606 6808 5989	1058.16 943.49 833.78 746.01 655.11	43553 51103 56993 61179 64836	0.8 0.9 1.1 1.2 1.3	KR775-90L/4	3,5	423	144	KR112
	2.3 2.5 2.9 3.2	5778 5171 4549 4074	396.00 354.32 311.14 278.35	65738 68182 70492 72208	1.4 1.5 1.8 2.0	KR774-100L/6	3,5	410	140	KR113
	3.5 4.0 4.5 5.0 5.8	3714 3324 2924 2619 2262	396.00 354.32 311.14 278.35 240.71	73306 74526 75815 76632 77566	2.2 2.4 2.7 3.1 3.5	KR774-90L/4	3,5	405	140	KR114
	2.5 2.8 3.3	5289 4682 3983	363.81 321.51 273.88	15099 24242 31251	0.8 0.9 1.1	KR674-100L/6	3,5	304	128	KR115
	3.8 4.4 5.1 5.9 6.9 7.8 8.9	3400 3010 2561 2205 1916 1677 1476	363.81 321.51 273.88 235.44 204.32 178.62 157.02	35740 38334 40848 42678 44093 45118 45936	1.3 1.4 1.7 2.0 2.2 2.6 2.9	KR674-90L/4	3,5	298	128	KR116
	4.3 5.0 5.7 5.9 6.6	3059 2618 2300 2218 1974	328.56 281.00 246.42 237.97 211.51	18493 23465 26295 26951 28762	0.9 1.0 1.2 1.2 1.4	KR574-90L/4	3,5	158	116	KR117
	7.2	1857	125.51	29594	1.5	KR573-100L/6	3,5	151	112	KR118



# K Serisi Motorlu Güç Devir Sayfaları

## K Series Geared Motors Performance Tables

### K Serien Getriebemotoren Leistung und Drehzahlübersicht



Güç	Çıkış Devri	Çıkış Momenti	Çevrim Oranı	Güv. Rad. Yük Çıkış	Servis Faktörü	Tipi	Anma Akımı	Ağırlık	Ölçü Sayfası	Fiyat Kodu						
Power	Output Speeds	Output Torque	Ratio	Per.O. Loads (Output)	Service Factors	Type	Rated Current	Weight	Dim. Page	Price Ref.						
Leistung P <sub>g</sub> [kW] P <sub>g</sub> [HP]	Abtriebswelle Drehzahlen n <sub>2</sub> [r.p.m]	Abtriebswelle Drehmomente M <sub>2</sub> [Nm]	Übersetzung i	Zul.Querkräfte (Abtrieb) F <sub>qam</sub> [N]	Betriebsfaktor f <sub>s</sub>	Typ	Nennstrom [A]	Gewicht ~ [kg]	Maße Seite	Preis No.						
1.5 2.0	8.2	1627	<b>109.86</b>	31010	1.7	<b>KR573-100L/6</b>	3,5	151	112	KR118						
	9.3	1441	<b>97.19</b>	32115	1.9											
	11	1219	<b>82.14</b>	33229	2.2											
	13	1000	<b>67.37</b>	34273	2.7											
	15	884	<b>59.49</b>	34795	3.1											
8.1	1638	<b>110.65</b>	15902	0.9	<b>KR473-100L/6</b>	3,5	105	100	KR119							
9.1 10 13 14 16 18 22 23	9.1	1464	<b>153.47</b>	17616	1.1	<b>KR473-90L/4</b>	3,5	98	100	KR120						
	10	1297	<b>135.98</b>	18904	1.2											
	13	1057	<b>110.65</b>	20504	1.5											
	14	935	<b>97.79</b>	21250	1.7											
	16	837	<b>87.49</b>	21778	1.9											
	18	736	<b>76.83</b>	22263	2.1											
	22	615	<b>64.17</b>	22880	2.5											
	23	582	<b>60.63</b>	23035	2.7											
	13 14 18 20 23 27 32 38 42	13	1055	<b>110.61</b>	8645						0.8	<b>KR373-90L/4</b>	3,5	67	88	KR121
		14	928	<b>97.26</b>	10733						0.9					
18		748	<b>78.29</b>	12947	1.1											
20		657	<b>68.65</b>	13855	1.2											
23		581	<b>60.69</b>	14526	1.4											
27		489	<b>51.05</b>	15258	1.7											
32		417	<b>43.40</b>	15795	2.0											
38		357	<b>37.19</b>	16179	2.3											
42		324	<b>33.65</b>	16391	2.5											
24 28 32 38 46 55 61 73 88 105 117 141 169 202	24	556	<b>58.15</b>	11297	0.8	<b>KR273-90L/4</b>	3,5	33	80	KR122						
	28	483	<b>50.51</b>	11830	0.9											
	32	423	<b>44.20</b>	12228	1.1											
	38	351	<b>36.55</b>	12652	1.3											
	46	293	<b>30.48</b>	12978	1.5											
	55	246	<b>25.55</b>	13298	1.7											
	61	223	<b>23.08</b>	13483	1.8											
	73	184	<b>19.08</b>	13706	2.1											
	88	154	<b>15.92</b>	13898	2.4											
	105	129	<b>13.34</b>	14041	2.7											
	117	116	<b>12.00</b>	14005	2.2											
	141	96	<b>9.92</b>	13354	2.5											
	169	80	<b>8.28</b>	12746	2.9											
	202	67	<b>6.94</b>	12170	3.3											
	210 233 282 338 404	210	65	<b>13.34</b>	14341						4.0	<b>KR273-90S/2</b>	3,3	32	80	KR123
233		58	<b>12.00</b>	14005	3.8											
282		48	<b>9.92</b>	13354	4.0											
338		40	<b>8.28</b>	12746	4.0											
404		34	<b>6.94</b>	12170	4.0											
2.2 3.0	1.5	12851	<b>957.34</b>	88777	1.2	<b>KR875-100L/4a</b>	5,1	680	156	KR124						
	1.7	11348	<b>844.51</b>	94943	1.3											
	1.9	10104	<b>751.30</b>	99325	1.5											
	2.1	9058	<b>673.01</b>	102788	1.7											
2.3 2.7	2.3	8221	<b>383.99</b>	105381	1.8	<b>KR874-112M/6</b>	5,1	677	152	KR125						
	2.7	7285	<b>339.70</b>	108113	2.1											
3.2	6026	<b>438.70</b>	111461	2.5	<b>KR874-100L/4a</b>	5,1	667	152	KR126							



# K Serisi Motorlu Güç Devir Sayfaları

## K Series Geared Motors Performance Tables

### K Serien Getriebemotoren Leistung und Drehzahlübersicht



Güç	Çıkış Devri	Çıkış Momenti	Çevrim Oranı	Güv. Rad. Yük Çıkış	Servis Faktörü	Tipi	Anma Akımı	Ağırlık	Ölçü Sayfası	Fiyat Kodu
Power	Output Speeds	Output Torque	Ratio	Per.O. Loads (Output)	Service Factors	Type	Rated Current	Weight	Dim. Page	Price Ref.
Leistung P <sub>g</sub> [kW] P <sub>g</sub> [HP]	Abtriebswelle Drehzahlen n <sub>2</sub> [r.p.m]	Abtriebswelle Drehmomente M <sub>2</sub> [Nm]	Übersetzung i	Zul.Querkräfte (Abtrieb) F <sub>qam</sub> [N]	Betriebsfaktor f <sub>s</sub>	Typ	Nennstrom [A]	Gewicht ~ [kg]	Maße Seite	Preis No.
2.2 3.0	3.7	5285	<b>383.99</b>	113349	2.8	<b>KR874-100L/4a</b>	5,1	689	152	KR126
	4.1	4683	<b>339.70</b>	114803	3.2					
	4.9	3967	<b>287.10</b>	116446	3.8					
	6.0	3258	<b>235.47</b>	118066	4.0					
1.9 2.1	9985	<b>746.01</b>	40584	0.8	<b>KR775-100L/4a</b>	5,1	402	144	KR127	
	8785	<b>655.11</b>	49825	0.9						
2.3 2.5 2.9 3.2	8474	<b>396.00</b>	51853	0.9	<b>KR774-112M/6</b>	5,1	386	140	KR128	
	7584	<b>354.32</b>	57118	1.1						
	6672	<b>311.14</b>	61797	1.2						
	5975	<b>278.35</b>	64946	1.3						
3.5 4.0 4.5 5.0 5.8 6.7 7.7	5447	<b>396.00</b>	67094	1.5	<b>KR774-100L/4a</b>	5,1	375	140	KR129	
	4875	<b>354.32</b>	69412	1.6						
	4289	<b>311.14</b>	71470	1.9						
	3841	<b>278.35</b>	72940	2.1						
	3318	<b>240.71</b>	74563	2.4						
	2877	<b>208.42</b>	75853	2.8						
	2520	<b>182.29</b>	76924	3.2						
3.9 4.4 5.1 6.0 6.9	4987	<b>363.81</b>	20298	0.9	<b>KR674-100L/4a</b>	5,1	272	128	KR130	
	4414	<b>321.51</b>	27260	1.0						
	3756	<b>273.88</b>	33105	1.1						
	3234	<b>235.44</b>	36863	1.3						
	2810	<b>204.32</b>	39478	1.5						
7.0 8.9 10	2800	<b>128.24</b>	39572	1.5	<b>KR673-112M/6</b>	5,1	227	124	KR131	
	2204	<b>100.90</b>	42770	2.0						
	1973	<b>90.21</b>	43814	2.2						
11 14 16	1806	<b>128.24</b>	44531	2.4	<b>KR673-100L/4a</b>	5,1	215	124	<b>KR229</b>	
	1422	<b>100.90</b>	46131	3.0						
	1273	<b>90.21</b>	46707	3.4						
5.7 5.9 6.6 7.7	3373	<b>246.42</b>	13572	0.8	<b>KR574-100L/4a</b>	5,1	163	116	KR132	
	3254	<b>237.97</b>	15643	0.8						
	2895	<b>211.51</b>	20454	0.9						
	2478	<b>180.90</b>	24775	1.1						
8.2 9.3	2389	<b>109.86</b>	25640	1.1	<b>KR573-112M/6</b>	5,1	158	112	KR133	
	2116	<b>97.19</b>	27777	1.3						
11 13 15 17 21 24	1758	<b>125.51</b>	30269	1.5	<b>KR573-100L/4a</b>	5,1	148	112	KR134	
	1541	<b>109.86</b>	31595	1.8						
	1365	<b>97.19</b>	32524	2.0						
	1155	<b>82.14</b>	33531	2.3						
	948	<b>67.37</b>	34536	2.8						
	838	<b>59.49</b>	35013	3.2						
13 14 16 18 22 23	1551	<b>110.65</b>	16830	1.0	<b>KR473-100L/4a</b>	5,1	103	100	KR135	
	1372	<b>97.79</b>	18310	1.1						
	1228	<b>87.49</b>	19362	1.3						
	1080	<b>76.83</b>	20338	1.4						
	903	<b>64.17</b>	21391	1.7						
	854	<b>60.63</b>	21666	1.8						





# K Serisi Motorlu Güç Devir Sayfaları

## K Series Geared Motors Performance Tables

### K Serien Getriebemotoren Leistung und Drehzahlübersicht



Güç	Çıkış Devri	Çıkış Momenti	Çevrim Oranı	Güv. Rad. Yük Çıkış	Servis Faktörü	Tipi	Anma Akımı	Ağırlık	Ölçü Sayfası	Fiyat Kodu
Power	Output Speeds	Output Torque	Ratio	Per.O. Loads (Output)	Service Factors	Type	Rated Current	Weight	Dim. Page	Price Ref.
Leistung P <sub>g</sub> [kW] P <sub>g</sub> [HP]	Abtriebswelle Drehzahlen n <sub>2</sub> [r.p.m]	Abtriebswelle Drehmomente M <sub>2</sub> [Nm]	Übersetzung i	Zul.Querkräfte (Abtrieb) F <sub>qam</sub> [N]	Betriebsfaktor f <sub>s</sub>	Typ	Nennstrom [A]	Gewicht ~ [kg]	Maße Seite	Preis No.
2.2 3.0	24	832	59.19	21782	1.9	KR473-100L/4a	5,1	103	100	KR135
	27	721	51.22	22388	2.1					
	31	629	44.64	22814	2.5					
	36	552	39.11	23162	2.8					
	47	427	30.11	23702	3.6					
	18	1097	78.29	7744	0.7	KR373-100L/4a	5,1	74	88	KR136
	20	964	68.65	10182	0.9					
	23	853	60.69	11716	1.0					
	27	718	51.05	13236	1.1					
	32	611	43.40	14269	1.3					
	38	525	37.19	14983	1.6					
	42	475	33.65	15337	1.7					
	49	407	28.85	15848	2.0					
	57	349	24.72	16230	2.3					
	64	311	21.90	16477	2.6					
75	265	18.62	16739	3.1						
32	621	44.20	10738	0.7	KR273-100L/4a	5,1	38	80	KR137	
38	515	36.55	11587	0.9						
46	430	30.48	12188	1.0						
55	361	25.55	12723	1.2						
61	327	23.08	13008	1.3						
73	271	19.08	13365	1.4						
88	226	15.92	13627	1.6						
105	190	13.34	13844	1.8						
117	170	12.00	13507	1.5						
141	141	9.92	12943	1.7						
169	118	8.28	12403	2.0						
202	99	6.94	11882	2.2						
210	95	13.34	14058	3.2	KR273-90L/2	4,65	35	80	KR138	
233	85	12.00	13507	2.6						
282	71	9.92	12943	3.0						
338	59	8.28	12403	3.4						
404	49	6.94	11882	3.8						
3.0 4.0	2.1	12352	673.01	90953	1.2	KR875-100L/4b	6,45	664	156	KR139
	2.4	10725	584.66	97131	1.4					
	2.7	9934	339.70	99909	1.5	KR874-132S/6	6,9	685	152	KR140
	3.2	8217	438.70	105388	1.8	KR874-100L/4b	6,45	645	152	KR141
	3.7	7207	383.99	108332	2.1					
	4.1	6386	339.70	110569	2.3					
	4.9	5410	287.10	113067	2.8					
	6.0	4442	235.47	115440	3.4					
	6.8	3930	207.95	116560	3.8					
	7.6	3498	184.83	117485	4.0					
	2.9	9098	311.14	47811	0.9	KR774-132S/6	6,9	400	140	KR142
	3.2	8148	278.35	53872	1.0					
	3.5	7428	396.00	57962	1.1	KR774-100L/4b	6,45	380	140	KR143
	4.0	6648	354.32	61897	1.2					
	4.5	5849	311.14	65476	1.4					
5.0	5238	278.35	67947	1.5						
5.8	4524	240.71	70592	1.8						



# K Serisi Motorlu Güç Devir Sayfaları

## K Series Geared Motors Performance Tables

### K Serien Getriebemotoren Leistung und Drehzahlübersicht



Güç	Çıkış Devri	Çıkış Momenti	Çevrim Oranı	Güv. Rad. Yük Çıkış	Servis Faktörü	Tipi	Anma Akımı	Ağırlık	Ölçü Sayfası	Fiyat Kodu				
Power	Output Speeds	Output Torque	Ratio	Per.O. Loads (Output)	Service Factors	Type	Rated Current	Weight	Dim. Page	Price Ref.				
Leistung P <sub>g</sub> [kW] P <sub>g</sub> [HP]	Abtriebswelle Drehzahlen n <sub>2</sub> [r.p.m]	Abtriebswelle Drehmomente M <sub>2</sub> [Nm]	Übersetzung i	Zul.Querkräfte (Abtrieb) F <sub>qam</sub> [N]	Betriebsfaktor f <sub>s</sub>	Typ	Nennstrom [A]	Gewicht ~ [kg]	Maße Seite	Preis No.				
3.0 4.0	6.7	3924	208.42	72636	2.0	KR774-100L/4b	6,45	380	140	KR143				
	7.7	3437	182.29	74253	2.3									
	8.1	3330	111.63	74513	2.4	KR773-132S/6	6,9	382	136	KR144				
	9.1	2957	99.00	75617	2.7									
	10	2648	88.57	76488	3.0									
	12	2288	76.59	77512	3.5									
	5.1	5121	273.88	18223	0.8	KR674-100L/4b	6,45	275	128	KR145				
	6.0	4409	235.44	27179	1.0									
	6.9	3832	204.32	32506	1.1									
	7.0	3815	128.24	32717	1.1	KR673-132S/6	6,9	232	124	KR146				
	8.9	3003	100.90	38324	1.4									
	10	2688	90.21	40196	1.6									
	11	2464-	128.24	41421	1.7	KR673-100L/4b	6,45	217	124	KR230				
	14	1940	100.90	43864	2.2									
	16	1736	90.21	44832	2.5									
	17	1549	80.38	45620	2.8									
	7.7	3379	180.90	13438	0.8	KR574-100L/4b	6,45	166	116	KR147				
	9.3	2883	97.19	20736	0.9	KR574-132S/6	6,9	178	116	KR148				
11	2399	125.51	25717	1.1	KR573-100L/4b	6,45	151	112	KR149					
13	2102	109.86	27992	1.3										
14	1862	97.19	29610	1.5										
17	1576	82.14	31337	1.7										
21	1293	67.37	32874	2.1										
24	1143	59.49	33619	2.4										
27	1017	52.88	34244	2.7										
29	931	97.19	34621	2.9	KR573-100L/2	6,0	149	112	KR150					
34	788	82.14	35608	3.3										
14	1873	97.79	13340	0.8	KR473-100L/4b	6,45	107	100	KR151					
16	1675	87.49	15567	0.9										
18	1473	76.83	17437	1.1										
22	1232	64.17	19260	1.3										
23	1165	60.63	19785	1.3										
24	1136	59.19	19957	1.4										
27	984	51.22	20938	1.6										
31	859	44.64	21638	1.8										
36	753	39.11	22191	2.1										
56	488	25.15	23442	3.2										
27	980	51.05	9894	0.8						KR373-100L/4b	6,45	77	88	KR152
32	834	43.40	11945	1.0										
38	716	37.19	13261	1.1										
42	648	33.65	13915	1.3										
49	555	28.85	14728	1.5										
57	476	24.72	15349	1.7										
64	425	21.90	15732	1.9										
75	362	18.62	16147	2.3										
88	311	15.96	16473	2.6										
97	281	14.44	16646	2.9										



# K Serisi Motorlu Güç Devir Sayfaları

## K Series Geared Motors Performance Tables

### K Serien Getriebemotoren Leistung und Drehzahlübersicht



Güç	Çıkış Devri	Çıkış Momenti	Çevrim Oranı	Güv. Rad. Yük Çıkış	Servis Faktörü	Tipi	Anma Akımı	Ağırlık	Ölçü Sayfası	Fiyat Kodu					
Power	Output Speeds	Output Torque	Ratio	Per.O. Loads (Output)	Service Factors	Type	Rated Current	Weight	Dim. Page	Price Ref.					
Leistung	Abtriebswelle Drehzahlen	Abtriebswelle Drehmomente	Übersetzung	Zul.Querkräfte (Abtrieb)	Betriebsfaktor	Typ	Nennstrom	Gewicht	Maße Seite	Preis No.					
P <sub>g</sub> [kW] P <sub>g</sub> [HP]	n <sub>2</sub> [r.p.m]	M <sub>2</sub> [Nm]	i	F <sub>qam</sub> [N]	f <sub>s</sub>		[A]	[kg]							
3.0 4.0	46	586	30.48	11059	0.8	KR273-100L/4b	6,45	42	80	KR153					
	55	492	25.55	11907	0.9										
	61	446	23.08	12336	0.9										
	73	369	19.08	12892	1.1										
	88	309	15.92	13286	1.2										
	105	259	13.34	13513	1.4										
	117	232	12.00	12939	1.1										
	141	192	9.92	12473	1.2										
	169	161	8.28	12011	1.4										
	202	135	6.94	11554	1.6										
	117	232	12.00	12939	1.1										
	141	192	9.92	12473	1.2										
	169	161	8.28	12011	1.4										
	202	135	6.94	11554	1.6										
	210	130	13.34	13513	2.3						KR273-100L/2	6,0	38	80	KR154
	233	116	12.00	12939	1.9										
	282	96	9.92	12473	2.2										
	338	80	8.28	12011	2.5										
404	67	6.94	11554	2.8											
4.0 5.5	2.7	12586	514.05	89993	1.2	KR875-112M/4	8,2	670	156	KR155					
	3.0	11366	463.83	94758	1.3										
	3.6	9609	383.99	101005	1.6	KR874-112M/4	8,2	654	152	KR156					
	4.1	8515	339.70	104504	1.8										
	4.9	7213	287.10	108474	2.1										
	5.9	5923	235.47	111834	2.5										
	6.7	5240	207.95	113509	2.9										
	7.6	4665	184.83	114868	3.2										
	8.7	4079	161.34	116332	3.7										
	9.8	3604	142.32	117276	4.0										
	3.5	9904	396.00	41117	0.8	KR774-112M/4	8,2	387	160	KR157					
	4.0	8864	354.32	49280	0.9										
	4.5	7798	311.14	55914	1.0										
	5.0	6984	278.35	60237	1.1										
	5.8	6032	240.71	64660	1.3										
	6.7	5232	208.42	67951	1.5										
	7.7	4582	182.29	70443	1.7										
	8.1	4445	111.63	70973	1.8	KR773-132M/6a	9,0	401	136	KR158					
	9.1	3946	99.00	72563	2.0										
	10	3534	88.57	73876	2.3										
	12	3054	76.59	75378	2.6										
	14	2648	66.32	76492	3.0										
	16	2319	58.00	77404	3.4										
	7.0	5091	128.24	19073	0.8	KR673-132M/6a	9,0	232	124	KR159					
	8.9	4008	100.90	31129	1.1										
	10.0	3587	90.21	34457	1.2										
	11	3286	128.24	36660	1.3	KR673-112M/4	8,2	227	124	KR160					
	14	2588	100.90	40811	1.7										
	16	2316	90.21	42194	1.9										
	17	2066	80.38	43322	2.1										
13	2804	109.86	21813	1.0	KR573-112M/4	8,2	158	112	KR161						



# K Serisi Motorlu Güç Devir Sayfaları

## K Series Geared Motors Performance Tables

### K Serien Getriebemotoren Leistung und Drehzahlübersicht



Güç	Çıkış Devri	Çıkış Momenti	Çevrim Oranı	Güv. Rad. Yük Çıkış	Servis Faktörü	Tipi	Anma Akımı	Ağırlık	Ölçü Sayfası	Fiyat Kodu
Power	Output Speeds	Output Torque	Ratio	Per.O. Loads (Output)	Service Factors	Type	Rated Current	Weight	Dim. Page	Price Ref.
Leistung P <sub>g</sub> [kW] P <sub>g</sub> [HP]	Abtriebswelle Drehzahlen n <sub>2</sub> [r.p.m]	Abtriebswelle Drehmomente M <sub>2</sub> [Nm]	Übersetzung i	Zul.Querkräfte (Abtrieb) F <sub>qam</sub> [N]	Betriebsfaktor f <sub>s</sub>	Typ	Nennstrom [A]	Gewicht ~ [kg]	Maße Seite	Preis No.
4.0 5.5	14	2484	97.19	24908	1.1	KR573-112M/4	8,2	158	112	KR161
	17	2102	82.14	27930	1.3					
	21	1725	67.37	30497	1.6					
	24	1525	59.49	31617	1.8					
	26	1357	52.88	32561	2.0					
	31	1150	44.73	33973	2.3					
	37	982	38.16	35260	2.5					
	42	864	67.37	35960	2.8	KR573-112M/2	7,8	154	112	KR162
	47	764	59.49	36700	3.1					
	22	1644	64.17	15837	0.9	KR473-112M/4	8,2	114	90	KR163
	23	1554	60.63	16692	1.0					
	24	1515	59.19	17042	1.0					
	27	1313	51.22	18715	1.2					
	31	1146	44.64	19888	1.4					
	36	1005	39.11	20778	1.5					
	46	778	30.11	22058	2.0					
	56	651	25.15	22805	2.4					
	59	615	23.76	22529	2.5					
	60	600	23.19	22412	2.6					
	70	520	20.07	21705	2.9					
	80	454	17.49	21029	3.1					
32	1113	43.40	7361	0.7	KR373-112M/4	8,2	83	88	KR164	
38	955	37.19	10281	0.9						
42	865	33.65	11543	0.9						
49	741	28.85	12988	1.1						
57	636	24.72	14054	1.3						
64	567	21.90	14639	1.4						
75	483	18.62	15299	1.7						
88	414	15.96	15789	2.0						
97	375	14.44	16059	2.2						
113	322	12.38	16395	2.5						
132	276	10.60	16295	2.9						
61	595	23.08	11305	0.7	KR273-112M/4	8,2	49	80	KR165	
73	493	19.08	12169	0.8						
88	412	15.92	12773	0.9						
105	346	13.34	12831	1.0						
117	310	12.00	12228	0.8						
141	256	9.92	11885	0.9						
169	214	8.28	11521	1.1						
202	180	6.94	11143	1.2						
210	173	13.34	12831	1.7	KR273-112M/2	7,8	44	80	KR166	
233	155	12.00	12228	1.4						
282	129	9.92	11885	1.6						
338	107	8.28	11521	1.9						
404	90	6.94	11143	2.1						
5.5 7.5	4.1	11708	339.70	93538	1.3	KR874-132S/4	11,3	643	148	KR167
	4.9	9918	287.10	100050	1.5					
	5.9	8144	235.47	105670	1.8					
	6.7	7205	207.95	108370	2.1					



# K Serisi Motorlu Güç Devir Sayfaları

## K Series Geared Motors Performance Tables

### K Serien Getriebemotoren Leistung und Drehzahlübersicht



Güç	Çıkış Devri	Çıkış Momenti	Çevrim Oranı	Güv. Rad. Yük Çıkış	Servis Faktörü	Tipi	Anma Akımı	Ağırlık	Ölçü Sayfası	Fiyat Kodu
Power	Output Speeds	Output Torque	Ratio	Per.O. Loads (Output)	Service Factors	Type	Rated Current	Weight	Dim. Page	Price Ref.
Leistung	Abtriebswelle Drehzahlen	Abtriebswelle Drehmomente	Übersetzung	Zul.Querkräfte (Abtrieb)	Betriebsfaktor	Typ	Nennstrom	Gewicht	Maße Seite	Preis No.
P <sub>g</sub> [kW] P <sub>g</sub> [HP]	n <sub>2</sub> [r.p.m]	M <sub>2</sub> [Nm]	i	F <sub>qam</sub> [N]	f <sub>s</sub>		[A]	[kg]		
5.5 7.5	7.8	6360	115.87	110541	2.4	KR873-132M / 6B	12,3	645	148	KR230
	8.7	5673	103.24	112371	2.6					
	9.7	5105	92.80	113801	2.9					
	11	4456	81.06	115346	3.4					
5.0 5.8 6.7 7.7	5.0	9603	278.35	43675	0.8	KR774-132M/4	15,3	412	140	KR168
	5.8	8295	240.71	53122	1.0					
	6.7	7194	208.42	59303	1.1					
	7.7	6301	182.29	63537	1.3					
8.1 9.1 10 12	8.1	6116	111.63	64329	1.3	KR773-132M/6b	12,3	400	136	KR169
	9.1	5431	99.00	67180	1.5					
	10	4863	88.57	69355	1.6					
	12	4202	76.59	71755	1.9					
13 14 16 18 21	13	3946	111.63	72628	2.0	KR773-132S/4	11,3	382	136	KR170
	14	3504	99.00	74025	2.3					
	16	3138	88.57	75182	2.5					
	18	2712	76.59	76358	2.9					
	21	2352	66.32	77301	3.4					
10	4936	90.21	21007	0.9	KR673-132M/6b	12,3	232	124	KR171	
	11	4519	128.24	26442						1.0
14 17 21 24 26 31 37 40 46 54 62	14	3415	97.19	13241	0.8	KR573-132S/4	11,3	163	112	KR173
	17	2891	82.14	20804	0.9					
	21	2372	67.37	25809	1.1					
	24	2097	59.49	27974	1.3					
	26	1866	52.88	29553	1.4					
	31	1581	44.73	31750	1.7					
	37	1350	38.16	33588	1.9					
	40	1249	35.34	34340	1.9					
	46	1071	30.25	35323	2.1					
	54	919	25.78	34181	2.5					
62	813	22.77	33277	2.7						
27 31 36 46 56 59 60 70 80 91 102 118 135 154 187	27	1805	51.22	14043	0.9	KR473-132S/4	11,3	121	100	KR174
	31	1576	44.64	16466	1.0					
	36	1382	39.11	18136	1.1					
	46	1070	30.11	20362	1.4					
	56	895	25.15	21410	1.7					
	59	846	23.76	21514	1.8					
	60	825	23.19	21421	1.9					
	70	715	20.07	20847	2.1					
	80	624	17.49	20281	2.3					
	91	548	15.33	19726	2.5					
	102	489	13.71	18654	2.1					
	118	424	11.87	18116	2.3					
	135	370	10.34	17593	2.5					
	154	324	9.06	17085	2.8					
	187	268	7.48	16347	3.2					



# K Serisi Motorlu Güç Devir Sayfaları

## K Series Geared Motors Performance Tables

### K Serien Getriebemotoren Leistung und Drehzahlübersicht



Güç	Çıkış Devri	Çıkış Momenti	Çevrim Oranı	Güv. Rad. Yük Çıkış	Servis Faktörü	Tipi	Anma Akımı	Ağırlık	Ölçü Sayfası	Fiyat Kodu					
Power	Output Speeds	Output Torque	Ratio	Per.O. Loads (Output)	Service Factors	Type	Rated Current	Weight	Dim. Page	Price Ref.					
Leistung P <sub>g</sub> [kW] P <sub>g</sub> [HP]	Abtriebswelle Drehzahlen n <sub>2</sub> [r.p.m]	Abtriebswelle Drehmomente M <sub>2</sub> [Nm]	Übersetzung i	Zul.Querkräfte (Abtrieb) F <sub>qam</sub> [N]	Betriebsfaktor f <sub>s</sub>	Typ	Nennstrom [A]	Gewicht ~ [kg]	Maße Seite	Preis No.					
5,5 7,5	49	1019	28.85	9205	0.8	KR373-132S/4	11,3	86	88	KR175					
	57	874	24.72	11379	0.9										
	64	780	21.90	12560	1.1										
	75	664	18.62	13755	1.2										
	88	570	15.96	14577	1.4										
	97	516	14.44	15039	1.6										
	113	442	12.38	15586	1.9										
	132	379	10.60	15679	2.1										
	140	356	9.97	15125	1.8										
	164	306	8.54	14683	2.1										
	181	277	7.73	14389	2.2										
	211	237	6.63	13927	2.5										
	247	204	5.68	13456	2.8										
7.5 10	4.9	13525	287.10	85808	1.1	KR874-132M/4	15,3	681	152	KR177					
	6.0	11106	235.47	95759	1.4										
	6.7	9825	207.95	100298	1.5										
	7.6	8746	184.83	103797	1.7										
	8.7	7648	161.34	107224	2.0										
	9.9	6757	142.32	109621	2.2										
	7.8	8675	115.87	104040	1.7						KR873-160M/6	15,2	725	148	KR178
	8.7	7738	103.24	106688	1.9										
	9.7	6963	92.80	109012	2.2										
	11	6078	81.06	111369	2.5										
	13	5313	70.76	113407	2.8										
	14	4693	62.42	114803	3.2										
	12	5598	115.87	112586	2.7						KR873-132M/4	15,3	665	148	KR231
14	4994	103.24	114025	3.0											
15	4494	92.80	115152	3.3											
17	3923	81.06	116543	3.8											
8.0	8342	111.63	52779	1.0	KR773-160M/6	15,2	460	136	KR179						
9.1	7407	99.00	58094	1.1											
10	6633	88.57	61977	1.2											
12	5732	76.59	66002	1.4											
13	5383	111.63	67469	1.5	KR773-132M/4	15,3	400	136	KR180						
14	4780	99.00	69839	1.7											
16	4281	88.57	71539	1.9											
18	3699	76.59	73414	2.2											
21	3208	66.32	74953	2.5											
24	2810	58.00	76073	2.8											
27	2480	51.13	76937	3.2											
14	4854	100.90	22556	0.9						KR673-132M/4	15,3	249	124	KR181	
16	4344	90.21	28184	1.0											
17	3876	80.38	32322	1.1											
20	3299	68.47	36485	1.3											
24	2841	58.86	39388	1.5											
27	2469	51.08	41402	1.7											
31	2161	44.65	42928	2.0											
43	1589	32.68	45421	2.7											
50	1368	28.10	46361	3.1											
21	3236	67.37	16282	0.8	KR573-132M/4	15,3	180	112	KR182						
24	2861	59.49	21103	0.9											



# K Serisi Motorlu Güç Devir Sayfaları

## K Series Geared Motors Performance Tables

### K Serien Getriebemotoren Leistung und Drehzahlübersicht



Güç	Çıkış Devri	Çıkış Momenti	Çevrim Oranı	Güv. Rad. Yük Çıkış	Servis Faktörü	Tipi	Anma Akımı	Ağırlık	Ölçü Sayfası	Fiyat Kodu					
Power	Output Speeds	Output Torque	Ratio	Per.O. Loads (Output)	Service Factors	Type	Rated Current	Weight	Dim. Page	Price Ref.					
Leistung P <sub>g</sub> [kW] P <sub>g</sub> [HP]	Abtriebswelle Drehzahlen n <sub>2</sub> [r.p.m]	Abtriebswelle Drehmomente M <sub>2</sub> [Nm]	Übersetzung i	Zul.Querkräfte (Abtrieb) F <sub>qam</sub> [N]	Betriebsfaktor f <sub>s</sub>	Typ	Nennstrom [A]	Gewicht ~ [kg]	Maße Seite	Preis No.					
7.5 10	27	2546	52.88	24270	1.1	KR573-132M/4	15,3	180	112	KR182					
	31	2157	44.73	28085	1.2										
	37	1842	38.16	30935	1.4										
	40	1704	35.34	32073	1.4										
	46	1461	30.25	33479	1.6										
	54	1253	25.78	32609	1.8										
	62	1108	22.77	31889	2.0										
	69	986	20.24	31179	2.1										
	75	915	18.80	30724	2.2										
	88	775	15.88	29664	2.5										
	104	661	13.53	28636	2.8										
	121	566	11.58	27636	3.0										
	36	1885	39.11	13067	0.8						KR473-132M/4	15,3	138	100	KR183
	46	1459	30.11	17453	1.1										
	56	1221	25.15	19321	1.3										
59	1154	23.76	19794	1.3											
60	1126	23.19	19989	1.4											
70	976	20.07	19703	1.5											
80	852	17.49	19284	1.7											
91	747	15.33	18852	1.8											
102	667	13.71	17655	1.5											
118	578	11.87	17251	1.7											
135	504	10.34	16840	1.9											
154	443	9.06	16425	2.0											
187	366	7.48	15802	2.4											
225	304	6.21	15179	2.7											
236	290	11.87	17251	2.7	KR473-132S/2b	14,6	121	100	KR184						
271	253	10.34	16840	3.0											
309	222	9.06	16425	3.3											
64	1064	21.90	8360	0.8	KR373-132M/4	15,3	105	88	KR185						
75	906	18.62	10966	0.9											
88	777	15.96	12574	1.1											
97	704	14.44	13340	1.2											
113	603	12.38	14293	1.4											
132	518	10.60	14854	1.6											
140	486	9.97	14220	1.3											
164	417	8.54	13909	1.5											
181	378	7.73	13689	1.6											
211	324	6.63	13328	1.8											
247	278	5.68	12943	2.1											
264	259	10.60	14854	2.5						KR373-132S/2b	14,6	98	82	KR186	
281	244	9.97	14220	2.2											
328	209	8.54	13909	2.4											
362	189	7.73	13689	2.6											
423	162	6.63	13328	3.0											
11 15	7.6	12828	184.83	88871	1.2	KR874-160M/4	21,5	746	152	KR187					
	8.7	11217	161.34	95464	1.3										
	9.8	9910	142.32	100048	1.5										
	7.8	12730	115.87	89385	1.2	KR873-160L/6	22	746	148	KR188					
	8.7	11356	103.24	94825	1.3										
	9.7	10218	92.80	98922	1.5										
11	8919	81.06	103233	1.7											



# K Serisi Motorlu Güç Devir Sayfaları

## K Series Geared Motors Performance Tables

### K Serien Getriebemotoren Leistung und Drehzahlübersicht



Güç	Çıkış Devri	Çıkış Momenti	Çevrim Oranı	Güv. Rad. Yük Çıkış	Servis Faktörü	Tipi	Anma Akımı	Ağırlık	Ölçü Sayfası	Fiyat Kodu
Power	Output Speeds	Output Torque	Ratio	Per.O. Loads (Output)	Service Factors	Type	Rated Current	Weight	Dim. Page	Price Ref.
Leistung P <sub>g</sub> [kW] P <sub>g</sub> [HP]	Abtriebswelle Drehzahlen n <sub>2</sub> [r.p.m]	Abtriebswelle Drehmomente M <sub>2</sub> [Nm]	Übersetzung i	Zul.Querkräfte (Abtrieb) F <sub>qam</sub> [N]	Betriebsfaktor f <sub>s</sub>	Typ	Nennstrom [A]	Gewicht ~ [kg]	Maße Seite	Preis No.
11 15	12	8213	115.87	105498	1.8	KR873-160M/4	21,5	725	148	KR189
	14	7327	103.24	108095	2.0					
	15	6593	92.80	110090	2.3					
	17	5756	81.06	112392	2.6					
	20	5032	70.76	114064	3.0					
	22	4445	62.42	115398	3.4					
	10	9735	88.57	42764	0.8	KR773-160L/6	22	430	136	KR190
	12	8412	76.59	52182	1.0					
	13	7897	111.63	55500	1.0	KR773-160M/4	21,5	460	136	KR191
	14	7012	99.00	60322	1.1					
	16	6280	88.57	63717	1.3					
	18	5427	76.59	67275	1.5					
	21	4707	66.32	69977	1.7					
	24	4123	58.00	72021	1.9					
	27	3639	51.13	73568	2.2					
	31	3232	45.36	73881	2.5					
	35	2885	40.44	72236	2.8					
	36	2780	39.00	71706	2.9					
	41	2411	33.78	69585	3.3					
	20	4840	68.47	22665	0.9	KR673-160M/4	21,5	306	124	KR192
	24	4168	58.86	29790	1.0					
	27	3622	51.08	34245	1.2					
31	3171	44.65	37332	1.4						
36	2791	39.26	39583	1.5						
43	2331	32.68	42035	1.8						
50	2008	28.10	43626	2.1						
57	1745	24.38	42628	2.5						
66	1528	21.32	41620	2.8						
75	1345	18.74	40611	3.2						
31	3164	44.73	18368	0.8	KR573-160M/4	21,5	241	112	KR193	
37	2703	38.16	24612	0.9						
40	2500	35.34	26928	1.0						
46	2143	30.25	30251	1.1						
54	1839	25.78	29858	1.3						
62	1626	22.77	29459	1.4						
69	1447	20.24	29020	1.5						
75	1342	18.80	28718	1.5						
88	1136	15.88	27970	1.7						
104	969	13.53	27193	1.9						
121	831	11.58	26400	2.0						
125	802	11.22	25849	1.8						
148	679	9.48	25015	2.0						
173	579	8.07	24193	2.2						
203	497	6.91	23384	2.5						
60	1651	23.19	15670	0.9	KR473-160M/4	21,5	198	100	KR194	
70	1432	20.07	17700	1.0						
80	1250	17.49	17539	1.1						
91	1096	15.33	17323	1.2						
102	978	13.71	15907	1.0						
118	848	11.87	15738	1.1						
135	740	10.34	15521	1.3						
155	649	9.06	15270	1.4						
187	537	7.48	14848	1.6						
225	447	6.21	14387	1.9						





# K Serisi Motorlu Güç Devir Sayfaları

## K Series Geared Motors Performance Tables

### K Serien Getriebemotoren Leistung und Drehzahlübersicht



Güç	Çıkış Devri	Çıkış Momenti	Çevrim Oranı	Güv. Rad. Yük Çıkış	Servis Faktörü	Tipi	Anma Akımı	Ağırlık	Ölçü Sayfası	Fiyat Kodu
Power	Output Speeds	Output Torque	Ratio	Per.O. Loads (Output)	Service Factors	Type	Rated Current	Weight	Dim. Page	Price Ref.
Leistung P <sub>g</sub> [kW] P <sub>g</sub> [HP]	Abtriebswelle Drehzahlen n <sub>2</sub> [r.p.m]	Abtriebswelle Drehmomente M <sub>2</sub> [Nm]	Übersetzung i	Zul.Querkräfte (Abtrieb) F <sub>qam</sub> [N]	Betriebsfaktor f <sub>s</sub>	Typ	Nennstrom [A]	Gewicht ~ [kg]	Maße Seite	Preis No.
15 20	8.7	15487	103.24	76049	1.0	KR873-180L/6	29	769	148	KR195
	9.7	13936	92.80	83893	1.1					
	11	12165	81.06	91406	1.2					
	12	11201	115.87	95567	1.3	KR873-160L/4	29	746	148	KR196
	14	9993	103.24	99993	1.5					
	15	8993	92.80	103117	1.7					
	17	7850	81.06	106695	1.9					
	20	6864	70.76	109386	2.2					
	22	6063	62.42	111466	2.5					
	25	5401	55.53	113164	2.8					
	28	4844	49.75	114473	3.1					
	14	9564	99.00	44581	0.8	KR773-160L/4	29	481	136	KR197
	16	8566	88.57	51538	0.9					
	18	7402	76.59	58258	1.1					
	21	6420	66.32	62973	1.2					
	24	5623	58.00	66466	1.4					
	27	4963	51.13	69022	1.6					
	31	4409	45.36	69715	1.8					
	35	3935	40.44	68522	2.0					
	36	3792	39.00	68124	2.1					
	41	3289	33.78	66482	2.4					
	48	2866	29.40	64802	2.8					
	53	2590	26.52	63510	3.1					
	60	2301	23.52	61978	3.5					
	27	4940	51.08	21269	0.9	KR673-160L/4	29	343	124	KR198
	31	4324	44.65	28276	1.0					
	36	3806	39.26	32748	1.1					
	43	3179	32.68	37199	1.4					
	50	2738	28.10	39935	1.6					
	57	2380	24.38	39775	1.8					
	66	2084	21.32	39126	2.1					
	75	1834	18.74	38419	2.3					
	85	1622	16.54	37671	2.7					
	97	1414	14.49	36425	2.1					
	112	1218	12.46	35458	2.3					
	130	1059	10.81	34507	2.6					
	148	927	9.45	33577	2.8					
	169	816	8.31	32670	3.1					
	54	2508	25.78	26714	0.9	KR573-160L/4	29	261	112	KR199
	62	2218	22.77	26683	1.0					
	69	1974	20.24	26552	1.1					
	74	1831	18.80	26426	1.1					
	88	1550	15.88	26033	1.2					
	104	1322	13.53	25544	1.4					
	121	1134	11.58	24988	1.5					
	125	1094	11.22	24339	1.3					
	148	926	9.48	23739	1.5					
	173	790	8.07	23107	1.6					
	203	678	6.91	22454	1.8					
	80	1704	17.49	15545	0.8					
	91	1495	15.33	15576	0.9					
	102	1334	13.71	13909	0.8					
	118	1157	11.87	14009	0.8					
	135	1010	10.34	14014	0.9					
	154	886	9.06	13949	1.0					
	187	733	7.48	13757	1.2					



# K Serisi Motorlu Güç Devir Sayfaları

## K Series Geared Motors Performance Tables

### K Serien Getriebemotoren Leistung und Drehzahlübersicht



Güç	Çıkış Devri	Çıkış Momenti	Çevrim Oranı	Güv. Rad. Yük Çıkış	Servis Faktörü	Tipi	Anma Akımı	Ağırlık	Ölçü Sayfası	Fiyat Kodu
Power	Output Speeds	Output Torque	Ratio	Per.O. Loads (Output)	Service Factors	Type	Rated Current	Weight	Dim. Page	Price Ref.
Leistung P <sub>g</sub> [kW] P <sub>g</sub> [HP]	Abtriebswelle Drehzahlen n <sub>2</sub> [r.p.m]	Abtriebswelle Drehmomente M <sub>2</sub> [Nm]	Übersetzung i	Zul.Querkräfte (Abtrieb) F <sub>qam</sub> [N]	Betriebsfaktor f <sub>s</sub>	Typ	Nennstrom [A]	Gewicht ~ [kg]	Maße Seite	Preis No.
15 20	225	610	6.21	13482	1.4	KR473-160L/4	29	220	100	KR200
18.5 25	12	13317	113.42	86740	1.1	KR874-180M/4	36	794	152	KR201
	14	11571	98.53	94026	1.3					
	11	15001	81.06	78573	1.0	KR873-200L/6a	36	787	148	KR202
	13	13115	70.76	87503	1.1					
	14	12325	103.24	91172	1.2	KR873-180M/4	36	777	148	KR203
	15	11092	92.80	95940	1.4					
	17	9683	81.06	100974	1.5					
	20	8466	70.76	104770	1.8					
	22	7479	62.42	107639	2.0					
	25	6662	55.53	109915	2.3					
	28	5975	49.75	111691	2.5					
	32	5192	43.22	114214	2.8					
	37	4571	38.00	113404	3.1					
	18	9130	76.59	47707	0.9	KR773-180M/4	36	510	136	KR204
		21	7919	66.32	55288	1.0				
24		6936	58.00	60593	1.2					
27		6122	51.13	64329	1.3					
31		5438	45.36	66070	1.5					
35		4854	40.44	65271	1.6					
36		4677	39.00	64990	1.7					
41		4057	33.78	63767	2.0					
48		3535	29.40	62439	2.3					
53		3195	26.52	61379	2.5					
60		2838	23.52	60087	2.8					
67		2534	20.97	58800	3.2					
69	2441	20.23	58383	3.2						
31	5334	44.65	14592	0.8	KR673-180M/4	36	372	124	KR205	
	36	4695	39.26	24378	0.9					
	43	3922	32.68	31859	1.1					
	50	3377	28.10	35929	1.3					
	57	2936	24.38	37279	1.5					
	66	2570	21.32	36944	1.7					
	75	2263	18.74	36500	1.9					
	85	2000	16.54	35977	2.1					
	97	1744	14.49	34850	1.7					
	112	1502	12.46	34104	1.9					
	130	1306	10.81	33332	2.1					
	148	1143	9.45	32550	2.3					
169	1007	8.31	31766	2.5						
62	2736	22.77	24253	0.8	KR573-180M/4	36	294	112	KR206	
	69	2435	20.24	24392	0.9					
	75	2258	18.80	24420	0.9					
	88	1912	15.88	24338	1.0					
	104	1631	13.53	24101	1.1					
	121	1399	11.58	23753	1.2					
	125	1350	11.22	23019	1.1					
	148	1143	9.48	22623	1.2					
	173	975	8.07	22156	1.3					
	203	836	6.91	21641	1.5					



# K Serisi Motorlu Güç Devir Sayfaları

## K Series Geared Motors Performance Tables

### K Serien Getriebemotoren Leistung und Drehzahlübersicht



Güç	Çıkış Devri	Çıkış Momenti	Çevrim Oranı	Güv. Rad. Yük Çıkış	Servis Faktörü	Tipi	Anma Akımı	Ağırlık	Ölçü Sayfası	Fiyat Kodu						
Power	Output Speeds	Output Torque	Ratio	Per.O. Loads (Output)	Service Factors	Type	Rated Current	Weight	Dim. Page	Price Ref.						
Leistung	Abtriebswelle Drehzahlen	Abtriebswelle Drehmomente	Übersetzung	Zul.Querkräfte (Abtrieb)	Betriebsfaktor	Typ	Nennstrom	Gewicht	Maße Seite	Preis No.						
$P_g$ [kW] $P_g$ [HP]	$n_2$ [r.p.m]	$M_2$ [Nm]	$i$	$F_{qam}$ [N]	$f_s$		[A]	[kg]								
18.5 25	155	1093	9.06	12794	0.8	KR473-180M/4	36	252	100	KR207						
	187	904	7.48	12803	1.0											
	225	752	6.21	12690	1.1											
22 30	11	17843	81.06	61164	0.8	KR873-200L/6b	43	807	148	KR208						
	13	15599	70.76	75326	1.0											
22 30	14	14658	103.24	80674	1.0	KR873-180L/4	36	817	148	KR209						
	15	13191	92.80	87445	1.1											
	17	11515	81.06	94430	1.3											
	20	10068	70.76	99593	1.5											
	22	8894	62.42	103409	1.7											
	25	7923	55.53	106246	1.9											
	28	7106	49.75	108679	2.1											
	32	6175	43.22	111799	2.4											
	37	5436	38.00	111045	2.6											
	41	4911	34.28	108671	2.8											
	21	9417	66.32	45602	0.8						KR773-180L/4	36	551	136	KR210	
	24	8248	58.00	53423	1.0											
	27	7281	51.13	58806	1.1											
	31	6467	45.36	62424	1.2											
35	5773	40.44	62021	1.4												
36	5562	39.00	61856	1.4												
41	4825	33.78	61052	1.7												
48	4205	29.40	60077	1.9												
53	3800	26.52	59249	2.1												
60	3375	23.52	58197	2.4												
67	3013	20.97	57114	2.7												
69	2903	20.23	56758	2.7												
80	2519	17.52	55300	3.0												
92	2195	15.25	53829	3.3												
22 30	43	4664	32.68	24657	0.9	KR673-180L/4	36	412	124	KR211						
	50	4017	28.10	31053	1.1											
	57	3492	24.38	34783	1.2											
	66	3057	21.32	34761	1.4											
	75	2691	18.74	34582	1.6											
	85	2379	16.54	34283	1.8											
	97	2074	14.49	33275	1.4											
	112	1787	12.46	32749	1.6											
	130	1553	10.81	32156	1.7											
	148	1360	9.45	31523	1.9											
	169	1197	8.31	30863	2.1											
	22 30	88	2274	15.88	22643						0.8	KR573-180L/4	36	334	112	KR212
		104	1940	13.53	22658						0.9					
		121	1663	11.58	22518						1.0					
125		1605	11.22	21698	0.9											
148		1359	9.48	21506	1.0											
173		1160	8.07	21206	1.1											
203		994	6.91	20827	1.2											
187		1075	7.48	11849	0.8	KR473-180L/4	36	292	100	KR213						
225	894	6.21	11898	0.9												
30 40	17	15704	81.06	75080	1.0	KR873-200L/4	54	837	148	KR214						
	20	13730	70.76	85077	1.1											
	22	12130	62.42	91916	1.2											



# K Serisi Motorlu Güç Devir Sayfaları

## K Series Geared Motors Performance Tables

### K Serien Getriebemotoren Leistung und Drehzahlübersicht



Güç	Çıkış Devri	Çıkış Momenti	Çevrim Oranı	Güv. Rad. Yük Çıkış	Servis Faktörü	Tipi	Anma Akımı	Ağırlık	Ölçü Sayfası	Fiyat Kodu
Power	Output Speeds	Output Torque	Ratio	Per.O. Loads (Output)	Service Factors	Type	Rated Current	Weight	Dim. Page	Price Ref.
Leistung P <sub>g</sub> [kW] P <sub>g</sub> [HP]	Abtriebswelle Drehzahlen n <sub>2</sub> [r.p.m]	Abtriebswelle Drehmomente M <sub>2</sub> [Nm]	Übersetzung i	Zul.Querkräfte (Abtrieb) F <sub>qam</sub> [N]	Betriebsfaktor f <sub>s</sub>	Typ	Nennstrom [A]	Gewicht ~ [kg]	Maße Seite	Preis No.
30 40	25	10805	55.53	96855	1.4	KR873-200L/4	54	837	148	KR214
	28	9690	49.75	100818	1.5					
	32	8421	43.22	105597	1.8					
	37	7414	38.00	105651	1.9					
	41	6698	34.28	103805	2.1					
	47	5844	29.88	101215	2.3					
	58	4755	24.28	97124	3.0					
	27	9929	51.13	41528	0.8	KR773-200L/4	54	570	136	KR215
	31	8820	45.36	49772	0.9					
	35	7873	40.44	54591	1.0					
	36	7585	39.00	54691	1.1					
	41	6580	33.78	54846	1.2					
	48	5734	29.40	54676	1.4					
	53	5182	26.52	54378	1.5					
	60	4603	23.52	53876	1.7					
	67	4110	20.97	53261	1.9					
	69	3960	20.23	53043	2.0					
	80	3435	17.52	52082	2.2					
	92	2994	15.25	51029	2.4					
109	2525	12.89	48032	1.8						
122	2243	11.44	47150	2.0						
137	2003	10.20	46248	2.1						
142	1929	9.83	45952	2.2						
164	1674	8.52	44746	2.4						
189	1459	7.41	43534	2.7						
57	4762	24.38	23534	0.9	KR673-200L/4	54	429	124	KR216	
66	4169	21.32	29773	1.0						
75	3670	18.74	30196	1.2						
85	3244	16.54	30412	1.3						
97	2829	14.49	29673	1.0						
112	2437	12.46	29654	1.1						
130	2118	10.81	29470	1.3						
148	1855	9.45	29174	1.4						
169	1633	8.31	28799	1.5						
37 50	25	13327	55.53	86648	1.1	KR873-225S/4	66	885	148	KR217
	28	11952	49.75	92596	1.3					
	32	10386	43.22	99278	1.4					
	37	9145	38.00	100930	1.6					
	41	8261	34.28	99545	1.7					
	47	7209	29.88	97504	1.8					
	58	5865	24.28	94109	2.4					
	66	5164	21.34	91866	2.6					
	73	4665	19.26	90019	2.8					
	83	4071	16.78	87493	3.1					
	101	3372	13.93	82770	2.6					
	114	2969	12.25	80495	2.8					
	127	2682	11.05	78665	3.0					
	35	9710	40.44	43215	0.8	KR773-225S/4	66	608	136	KR218
	36	9356	39.00	45952	0.9					
	41	8116	33.78	49416	1.0					
	48	7073	29.40	49950	1.1					
	53	6392	26.52	50115	1.3					
	60	5678	23.52	50094	1.4					
67	5069	20.97	49890	1.6						
69	4884	20.23	49792	1.6						



# K Serisi Motorlu Güç Devir Sayfaları

## K Series Geared Motors Performance Tables

### K Serien Getriebemotoren Leistung und Drehzahlübersicht



Güç	Çıkış Devri	Çıkış Momenti	Çevrim Oranı	Güv. Rad. Yük Çıkış	Servis Faktörü	Tipi	Anma Akımı	Ağırlık	Ölçü Sayfası	Fiyat Kodu											
Power	Output Speeds	Output Torque	Ratio	Per.O. Loads (Output)	Service Factors	Type	Rated Current	Weight	Dim. Page	Price Ref.											
Leistung P <sub>g</sub> [kW] P <sub>g</sub> [HP]	Abtriebswelle Drehzahlen n <sub>2</sub> [r.p.m]	Abtriebswelle Drehmomente M <sub>2</sub> [Nm]	Übersetzung i	Zul.Querkräfte (Abtrieb) F <sub>qam</sub> [N]	Betriebsfaktor f <sub>s</sub>	Typ	Nennstrom [A]	Gewicht ~ [kg]	Maße Seite	Preis No.											
37 50	80	4237	17.52	49266	1.8	KR773-225S/4	66	608	136	KR218											
	92	3693	15.25	48578	2.0																
	109	3115	12.89	45587	1.4																
	122	2767	11.44	44981	1.6																
	137	2470	10.20	44314	1.7																
	142	2380	9.83	44087	1.8																
	164	2065	8.52	43131	2.0																
	189	1799	7.41	42129	2.2																
	66	5142	21.32	18017	0.8						KR673-225S/4	66	467	124	KR219						
	75	4527	18.74	26359	0.9																
	85	4001	16.54	27024	1.1																
	97	3489	14.49	26522	0.8																
	112	3006	12.46	26945	0.9																
	130	2613	10.81	27119	1.0																
	148	2288	9.45	27119	1.1																
	169	2014	8.31	26992	1.2																
	45 60	25	16209	55.53	72072											0.9	KR873-225M/4	80	911	148	KR220
		28	14537	49.75	81083											1.0					
32		12633	43.22	90803	1.2																
37		11123	38.00	95532	1.3																
41		10048	34.28	94675	1.4																
47		8768	29.88	93261	1.5																
58		7133	24.28	90663	2.0																
66		6281	21.34	88836	2.2																
73		5674	19.26	87285	2.3																
83		4951	16.78	85111	2.5																
101		4102	13.93	80525	2.1																
114		3612	12.25	78522	2.3																
127		3263	11.05	76885	2.5																
145		2847	9.63	74658	2.8																
41		9872	33.78	41799	0.8	KR773-225M/4	80	637	136	KR221											
48		8603	29.40	44549	0.9																
53		7775	26.52	45244	1.0																
60		6906	23.52	45773	1.2																
67		6165	20.97	46037	1.3																
69		5940	20.23	46076	1.3																
80		5154	17.52	46048	1.5																
92		4491	15.25	45777	1.6																
109		3788	12.89	42793	1.2																
122		3365	11.44	42502	1.3																
137		3005	10.20	42104	1.4																
142		2895	9.83	41956	1.5																
164		2511	8.52	41285	1.6																
189		2189	7.41	40522	1.8																
85		4867	16.54	22060	0.9						KR673-225M/4	80	496	124	KR222						
97		4244	14.49	22921	0.7																
112	3656	12.46	23849	0.8																	
130	3178	10.81	24432	0.8																	
148	2783	9.45	24770	0.9																	
169	2450	8.31	24927	1.0																	
55 75	25	19812	55.53	44582	0.8	KR873-250M/4	97	1023	148	KR223											
	28	17768	49.75	62040	0.8																
	32	15440	43.22	77807	1.0																
	37	13595	38.00	88781	1.0																
	41	12281	34.28	88585	1.1																
	47	10717	29.88	87954	1.2																



# K Serisi Motorlu Güç Devir Sayfaları

## K Series Geared Motors Performance Tables

### K Serien Getriebemotoren Leistung und Drehzahlübersicht



Güç	Çıkış Devri	Çıkış Momenti	Çevrim Oranı	Güv. Rad. Yük Çıkış	Servis Faktörü	Tipi	Anma Akımı	Ağırlık	Ölçü Sayfası	Fiyat Kodu						
Power	Output Speeds	Output Torque	Ratio	Per.O. Loads (Output)	Service Factors	Type	Rated Current	Weight	Dim. Page	Price Ref.						
Leistung P <sub>g</sub> [kW] P <sub>g</sub> [HP]	Abtriebswelle Drehzahlen n <sub>2</sub> [r.p.m]	Abtriebswelle Drehmomente M <sub>2</sub> [Nm]	Übersetzung i	Zul.Querkräfte (Abtrieb) F <sub>qam</sub> [N]	Betriebsfaktor f <sub>s</sub>	Typ	Nennstrom [A]	Gewicht ~ [kg]	Maße Seite	Preis No.						
55 75	58	8719	24.28	86353	1.6	KR873-250M/4	97	1023	148	KR223						
	66	7677	21.34	85047	1.8											
	73	6935	19.26	83867	1.9											
	83	6052	16.78	82133	2.1											
	101	5013	13.93	77718	1.7											
	114	4414	12.25	76054	1.9											
	127	3988	11.05	74658	2.0											
	145	3480	9.63	72718	2.3											
	53	9502	26.52	39154	0.8											
	60	8441	23.52	40371	0.9											
	67	7536	20.97	41220	1.1						KR773-250M/4	97	748	136	KR224	
	69	7261	20.23	41431	1.1											
	80	6299	17.52	42025	1.2											
	92	5490	15.25	42276	1.3											
	109	4631	12.89	39300	1.0											
	122	4114	11.44	39403	1.1											
	137	3672	10.20	39341	1.2											
	142	3538	9.83	39292	1.2											
	164	3070	8.52	38977	1.3											
189	2675	7.41	38514	1.5												
75 97	37	18539	38.00	61980	0.8	KR873-280S/4	133	1173	148	KR225						
	41	16748	34.28	76393	0.8											
	47	14615	29.88	77334	0.9											
	58	11890	24.28	77727	1.2											
	66	10470	21.34	77465	1.3											
	73	9458	19.26	77027	1.4											
	83	8253	16.78	76173	1.5											
	101	6837	13.93	72100	1.3											
	114	6020	12.25	71116	1.4											
	127	5439	11.05	70203	1.5											
	145	4746	9.63	68837	1.7											
	90 117	47	17538	29.88	69361						0.8	KR873-280M/4	158	1237	148	KR226
		58	14269	24.28	71253						1.0					
66		12564	21.34	71775	1.1											
73		11350	19.26	71894	1.2											
83		9905	16.78	71701	1.3											
101		8205	13.93	67884	1.1											
114		7225	12.25	67410	1.2											
127		6527	11.05	66860	1.2											
145		5696	9.63	65924	1.4											



# Ölçü Sayfaları

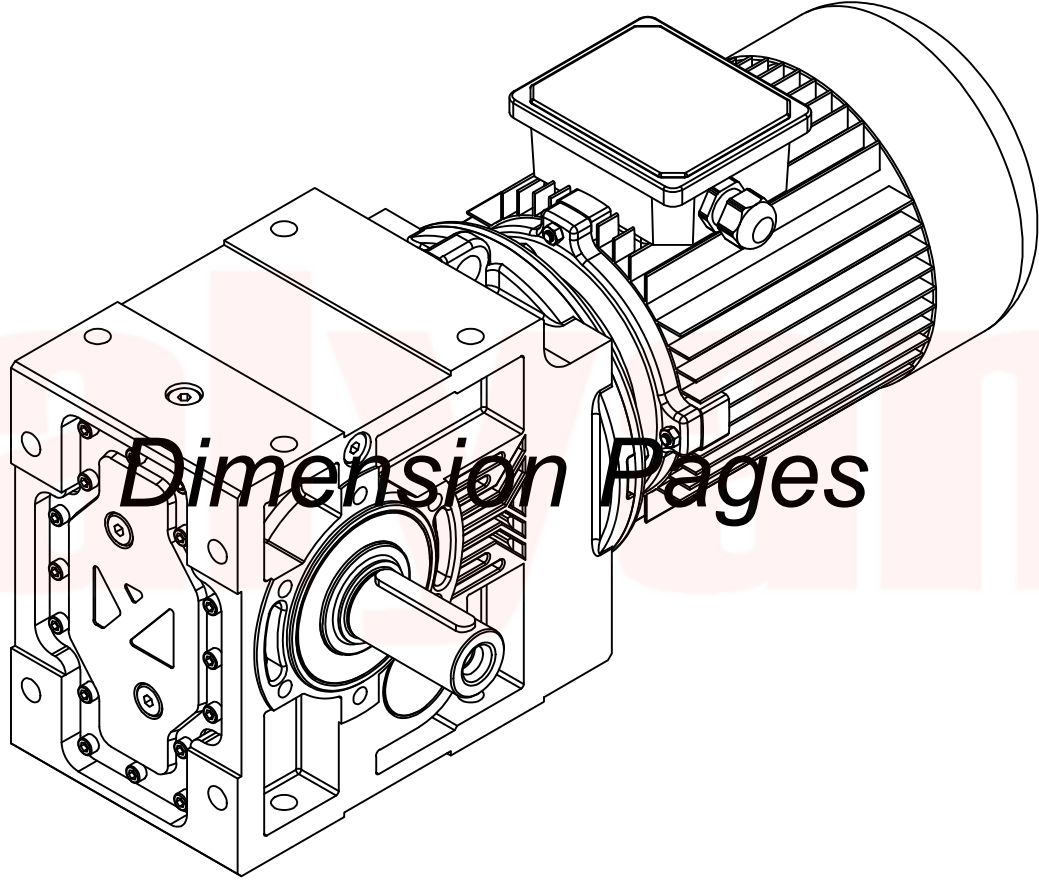

Dimension Pages

Abmessungenseiten



# Ölçü Sayfaları Dimension Pages Abmessungenseiten



-Mil ucu çektirme deliği DIN 332 sayfa 2 / Tapped center hole to DIN 332, sheet 2 / Zentrierung mit gewinde DIN 332, Blatt 2

## KR273.00

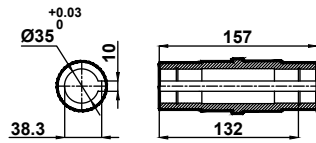
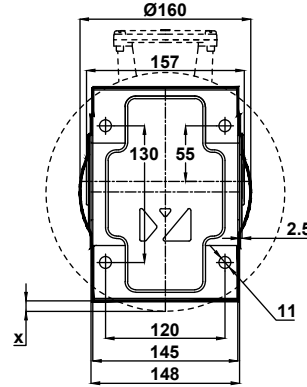
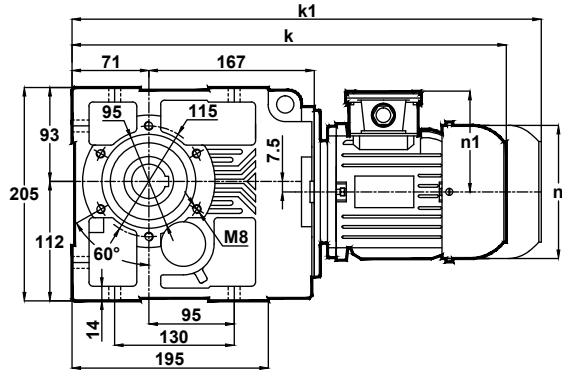

x: Motor Ayak bağlantı yüzeyinin altında ise  
x: If Motor is lower then foot mounting plane  
x: Wenn motor ist niedriger den die Anschlußplatte

Klemens Pozisyonları  
Terminal Box Positions  
Klemmenkasten Positionen

	63	71	80	90S	90L	100L	112M
k	431	449.5	478	506	531	572	595
k1	-	570	598	631	656	707	730
n	116	138	156	176	176	194	218
n1	97	110	118	126	126	135	146
x	-	-	-	-	-	-	4.5

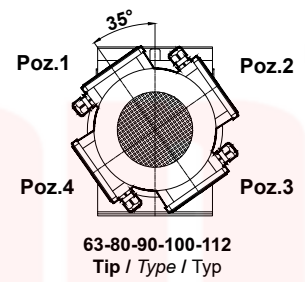
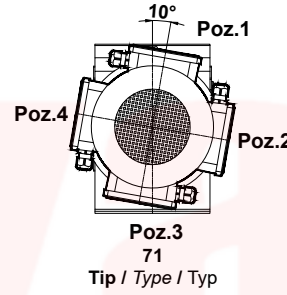

## KR273.01

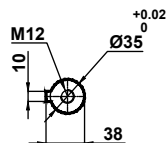
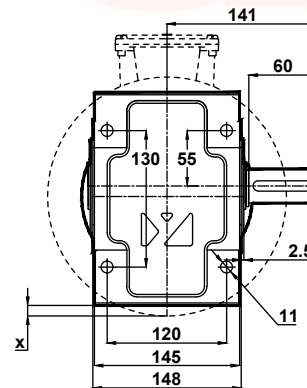
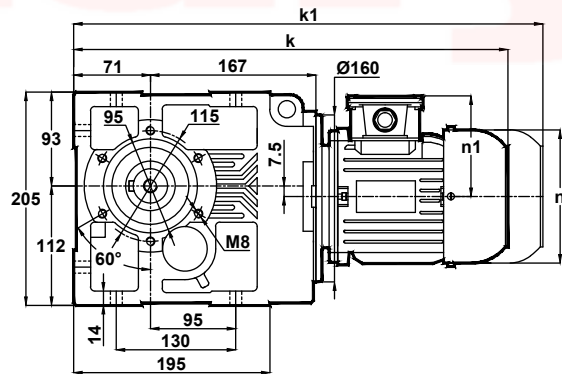

x: Motor Ayak bağlantı yüzeyinin altında ise  
x: If Motor is lower then foot mounting plane  
x: Wenn motor ist niedriger den die Anschlußplatte

	63	71	80	90S	90L	100L	112M
k	431	449.5	478	506	531	572	595
k1	-	570	598	631	656	707	730
n	116	138	156	176	176	194	218
n1	97	110	118	126	126	135	146
x	-	-	-	-	-	-	4.5





# Ölçü Sayfaları Dimension Pages Abmessungsseiten



-Mil ucu çektirme deliği DIN 332 sayfa 2 / Tapped center hole to DIN 332, sheet 2 / Zentrierung mit gewinde DIN 332, Blatt 2

## KR273.02

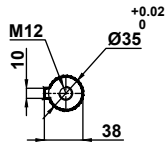
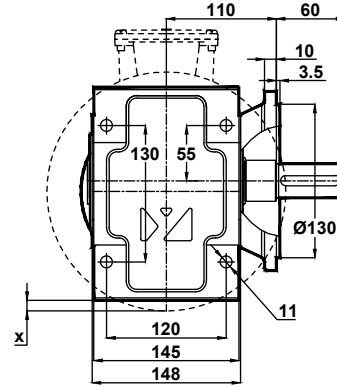
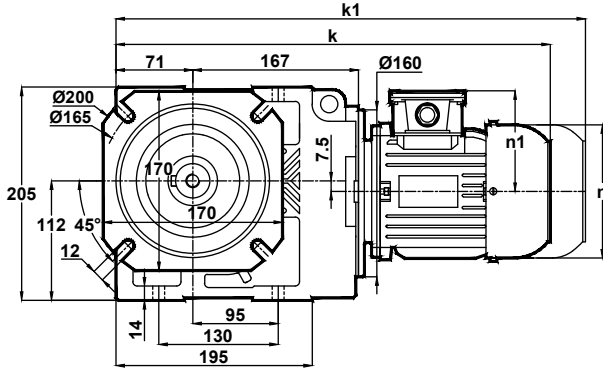

x: Motor Ayak bağlantı yüzeyinin altında ise  
x: If Motor is lower than foot mounting plane  
x: Wenn motor ist niedriger den die Anschlußplatte

Klemens Pozisyonları  
Terminal Box Positions  
Klemmenkasten Positionen

	63	71	80	90S	90L	100L	112M
k	431	449.5	478	506	531	572	595
k1	-	570	598	631	656	707	730
n	116	138	156	176	176	194	218
n1	97	110	118	126	126	135	146
x	-	-	-	-	-	-	4.5

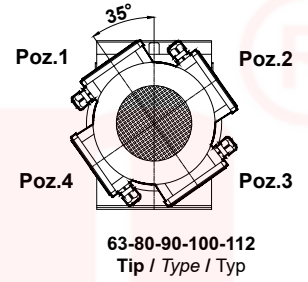
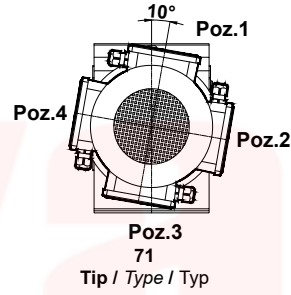

## KR273.03

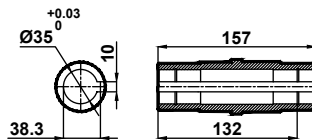
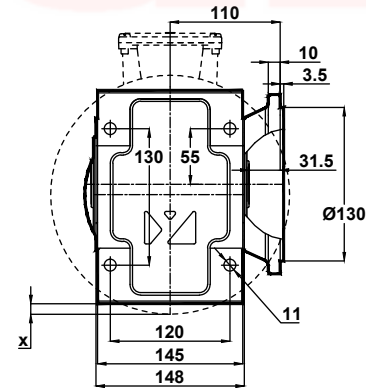
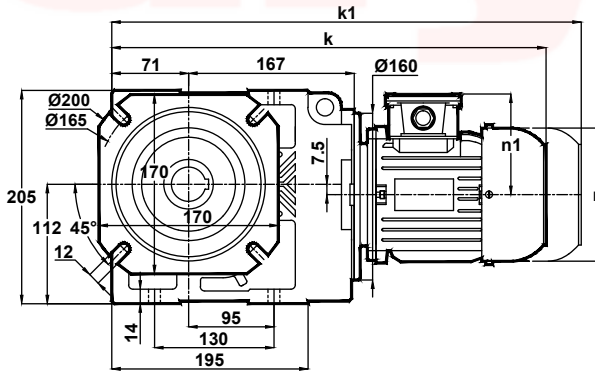

x: Motor Ayak bağlantı yüzeyinin altında ise  
x: If Motor is lower than foot mounting plane  
x: Wenn motor ist niedriger den die Anschlußplatte

	63	71	80	90S	90L	100L	112M
k	431	449.5	478	506	531	572	595
k1	-	570	598	631	656	707	730
n	116	138	156	176	176	194	218
n1	97	110	118	126	126	135	146
x	-	-	-	-	-	-	4.5



# Ölçü Sayfaları Dimension Pages Abmessungenseiten



-Mil ucu çektirme deliği DIN 332 sayfa 2 / Tapped center hole to DIN 332, sheet 2 / Zentrierung mit gewinde DIN 332, Blatt 2

## KR273.04

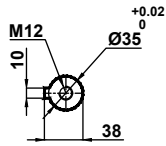
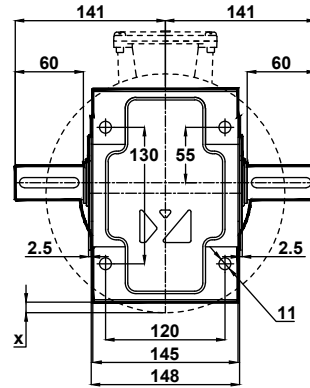
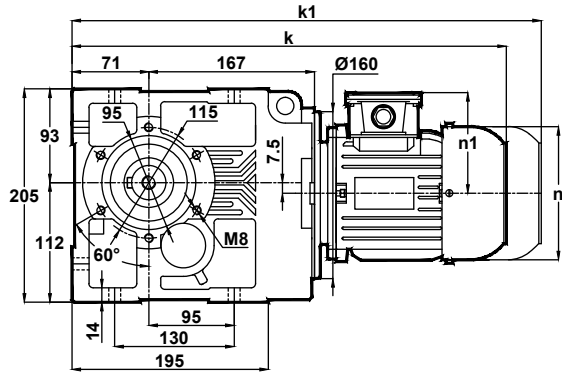

x: Motor Ayak bağlantı yüzeyinin altında ise  
x: If Motor is lower then foot mounting plane  
x: Wenn motor ist niedriger den die Anschlußplatte

	63	71	80	90S	90L	100L	112M
k	431	449.5	478	506	531	572	595
k1	-	570	598	631	656	707	730
n	116	138	156	176	176	194	218
n1	97	110	118	126	126	135	146
x	-	-	-	-	-	-	4.5

Klemens Pozisyonları  
Terminal Box Positions  
Klemmenkasten Positionen

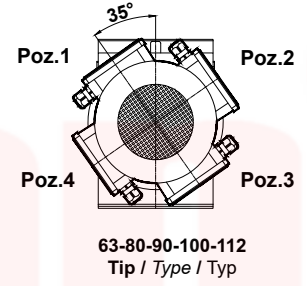
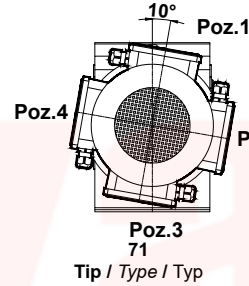

## KR273.05

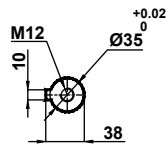
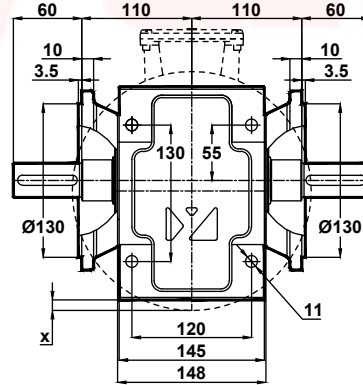
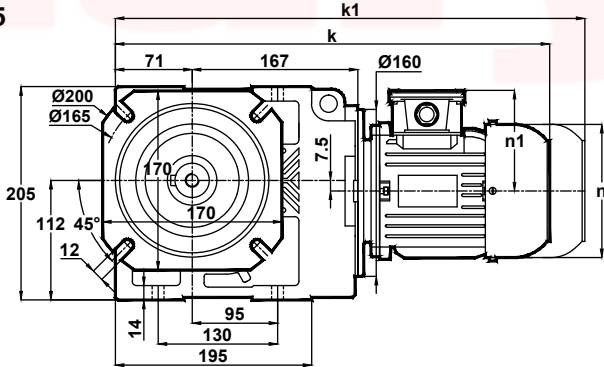

x: Motor Ayak bağlantı yüzeyinin altında ise  
x: If Motor is lower then foot mounting plane  
x: Wenn motor ist niedriger den die Anschlußplatte

	63	71	80	90S	90L	100L	112M
k	431	449.5	478	506	531	572	595
k1	-	570	598	631	656	707	730
n	116	138	156	176	176	194	218
n1	97	110	118	126	126	135	146
x	-	-	-	-	-	-	4.5



# Ölçü Sayfaları Dimension Pages Abmessungsseiten



-Mil ucu çektirme deliği DIN 332 sayfa 2 / Tapped center hole to DIN 332, sheet 2 / Zentrierung mit gewinde DIN 332, Blatt 2

KR273.08

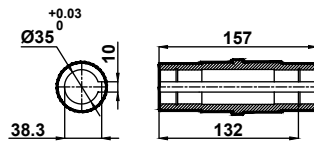
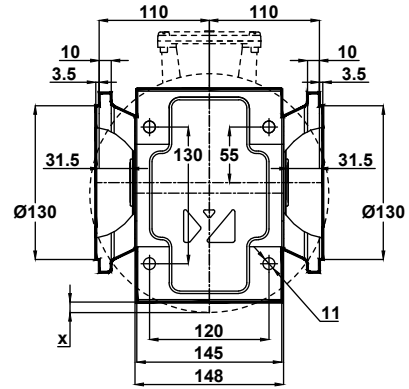
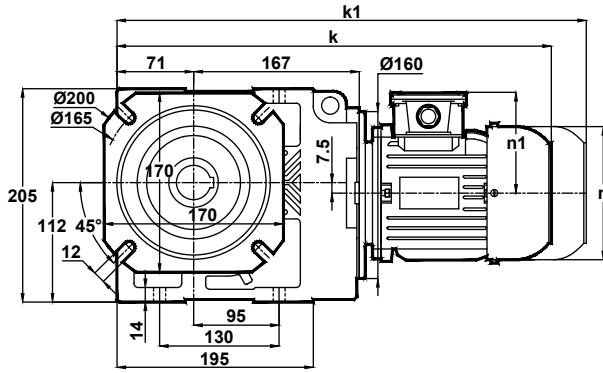

Klemens Pozisyonları  
Terminal Box Positions  
Klemmenkasten Positionen

	63	71	80	90S	90L	100L	112M
k	431	449.5	478	506	531	572	595
k1	-	570	598	631	656	707	730
n	116	138	156	176	176	194	218
n1	97	110	118	126	126	135	146
x	-	-	-	-	-	-	4.5

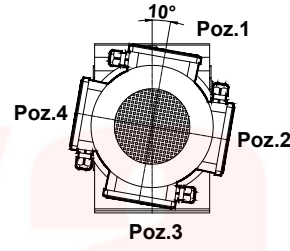

71  
Tip / Type / Typ

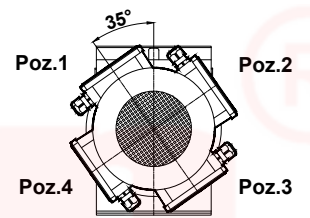

63-80-90-100-112  
Tip / Type / Typ



# Ölçü Sayfaları Dimension Pages Abmessungsseiten



-Mil ucu çekirme deliği DIN 332 sayfa 2 / Tapped center hole to DIN 332, sheet 2 / Zentrierung mit gewinde DIN 332, Blatt 2

KR275.00  
KR276.00

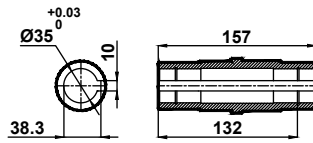
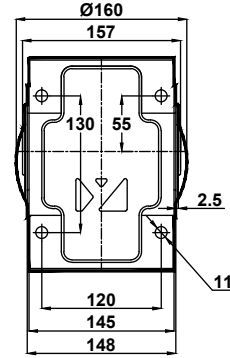
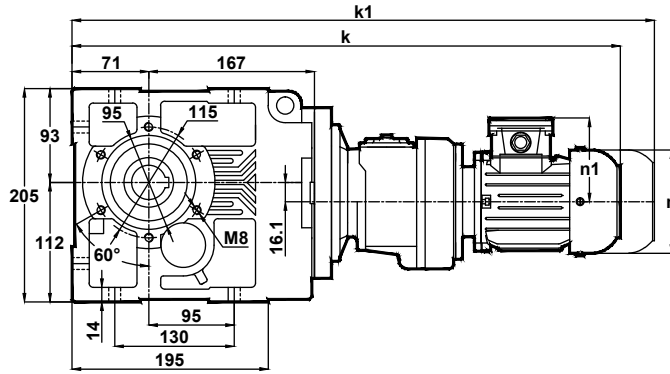

Klemens Pozisyonları  
Terminal Box Positions  
Klemmenkasten Positionen

	63	71	80	90S	90L
k	581	600	628	656	681
k1	-	720	748	781	806
n	116	138	156	176	176
n1	97	110	118	126	126

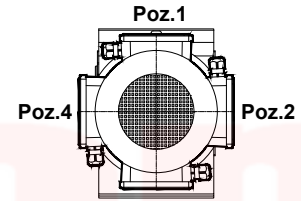

Poz.3  
63-71-80-90  
Tip / Type / Typ

KR275.01  
KR276.01

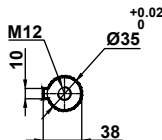
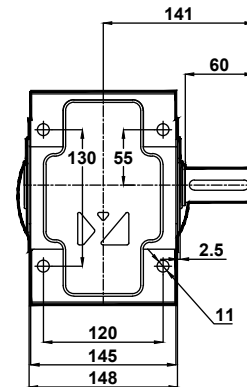
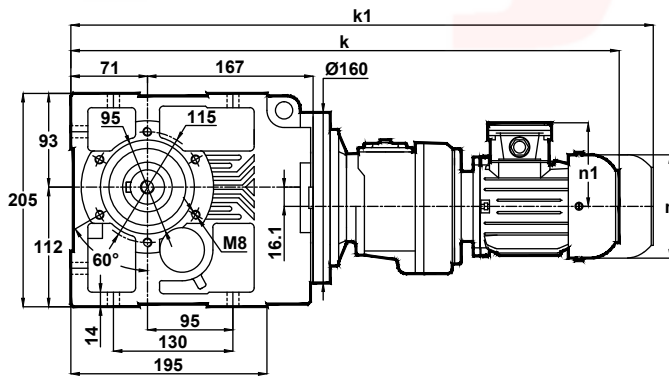

	63	71	80	90S	90L
k	581	600	628	656	681
k1	-	720	748	781	806
n	116	138	156	176	176
n1	97	110	118	126	126



# Ölçü Sayfaları Dimension Pages Abmessungsseiten



-Mil ucu çektirme deliği DIN 332 sayfa 2 / Tapped center hole to DIN 332, sheet 2 / Zentrierung mit gewinde DIN 332, Blatt 2

KR275.02  
KR276.02

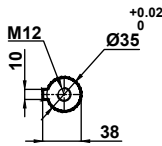
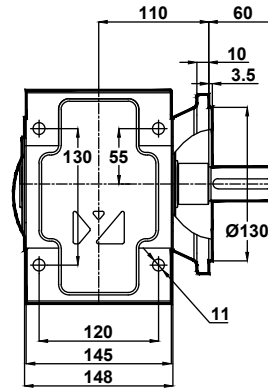
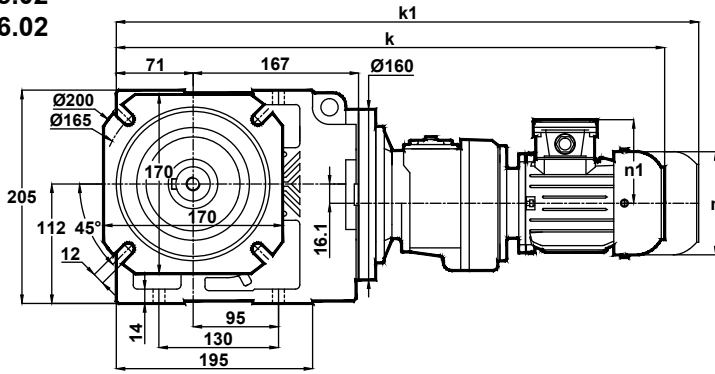

Klemens Pozisyonları  
Terminal Box Positions  
Klemmenkasten Positionen

	63	71	80	90S	90L
k	581	600	628	656	681
k1	-	720	748	781	806
n	116	138	156	176	176
n1	97	110	118	126	126

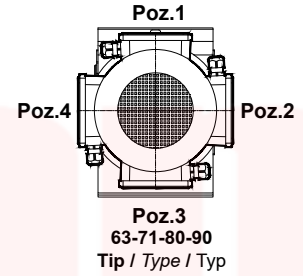

KR275.03  
KR276.03

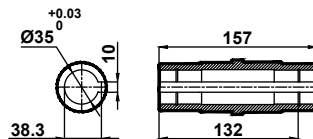
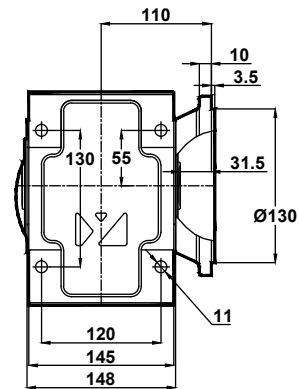
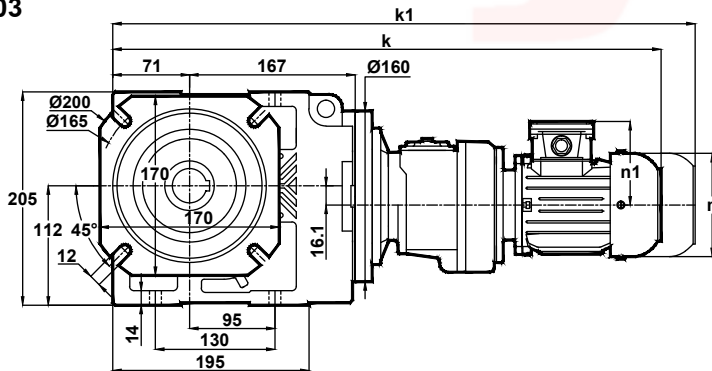

	63	71	80	90S	90L
k	581	600	628	656	681
k1	-	720	748	781	806
n	116	138	156	176	176
n1	97	110	118	126	126



# Ölçü Sayfaları Dimension Pages Abmessungsseiten



-Mil ucu çekirme deliği DIN 332 sayfa 2 / Tapped center hole to DIN 332, sheet 2 / Zentrierung mit gewinde DIN 332, Blatt 2

KR275.04  
KR276.04

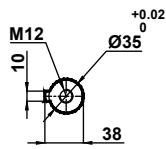
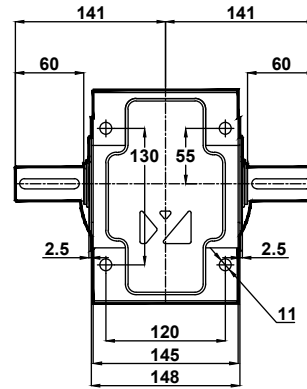
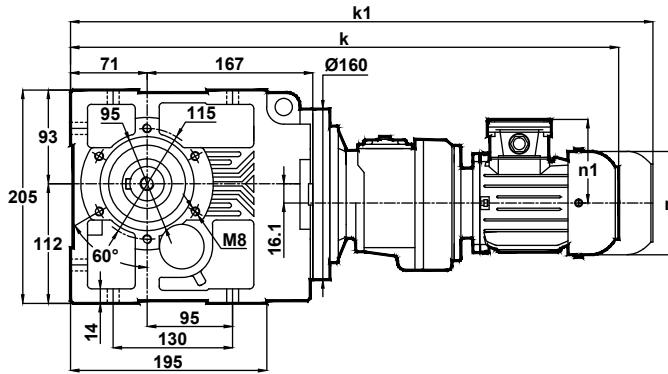

	63	71	80	90S	90L
k	581	600	628	656	681
k1	-	720	748	781	806
n	116	138	156	176	176
n1	97	110	118	126	126

Klemens Pozisyonları  
Terminal Box Positions  
Klemmenkasten Positionen

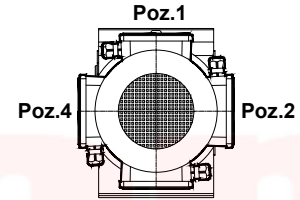

63-71-80-90  
Tip / Type / Typ

KR275.05  
KR276.05

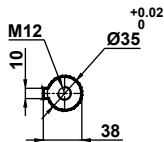
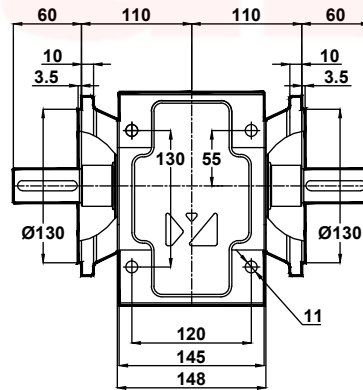
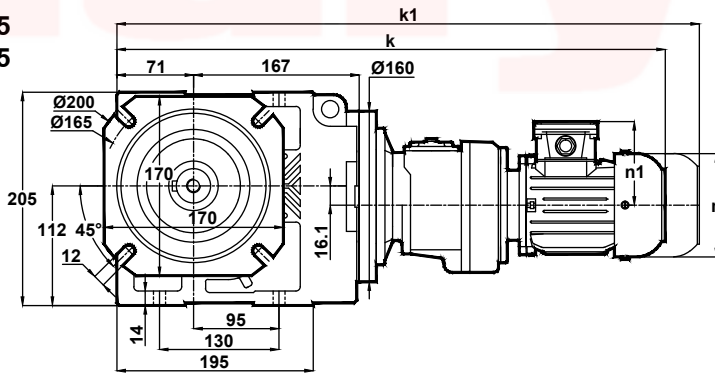

	63	71	80	90S	90L
k	581	600	628	656	681
k1	-	720	748	781	806
n	116	138	156	176	176
n1	97	110	118	126	126



# Ölçü Sayfaları

## Dimension Pages

### Abmessungsseiten



-Mil ucu çektirme deliği DIN 332 sayfa 2 / Tapped center hole to DIN 332, sheet 2 / Zentrierung mit gewinde DIN 332, Blatt 2

KR275.08  
KR276.08

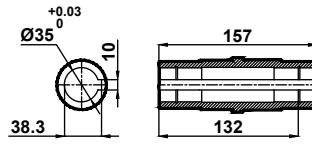
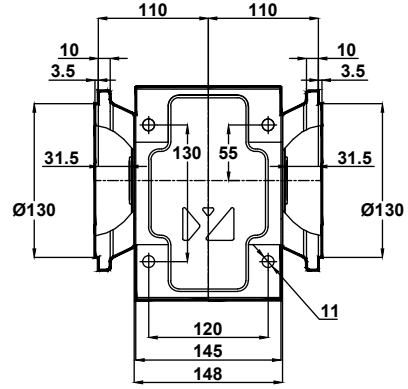
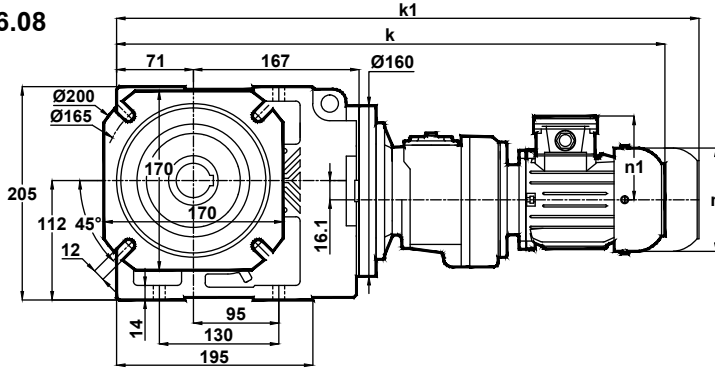

Klemens Pozisyonları  
Terminal Box Positions  
Klemmenkasten Positionen

	63	71	80	90S	90L
k	581	600	628	656	681
k1	-	720	748	781	806
n	116	138	156	176	176
n1	97	110	118	126	126

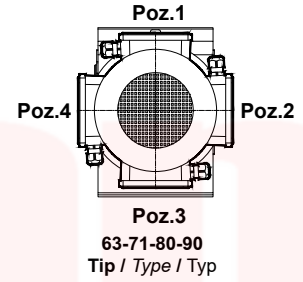



# Ölçü Sayfaları

## Dimension Pages

### Abmessungsseiten



-Mil ucu çekirme deliği DIN 332 sayfa 2 / Tapped center hole to DIN 332, sheet 2 / Zentrierung mit gewinde DIN 332, Blatt 2

#### KR373.00

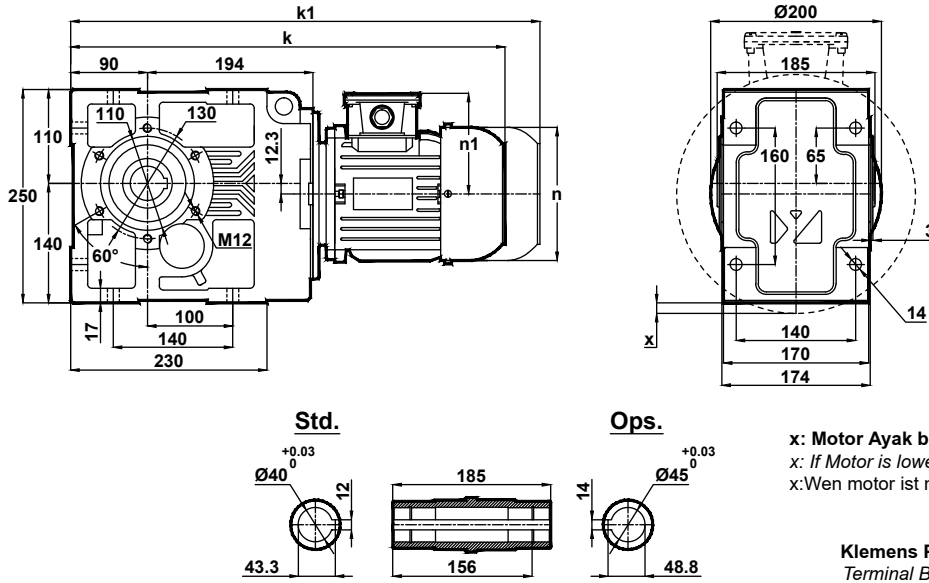

x: Motor Ayak bağlantı yüzeyinin altında ise  
x: If Motor is lower then foot mounting plane  
x:Wen motor ist nidriger den die Anschlußplatte

**Klemens Pozisyonları**  
Terminal Box Positions  
Klemmenkasten Positionen

	71	80	90S	90L	100L	112M	132S	132M
k	487	515	544	569	609	632	686	724
k1	607	635	669	694	744	767	831	869
n	138	156	176	176	194	218	258	258
n1	110	118	126	126	135	146	168	168
x	-	-	-	-	-	-	1.3	1.3

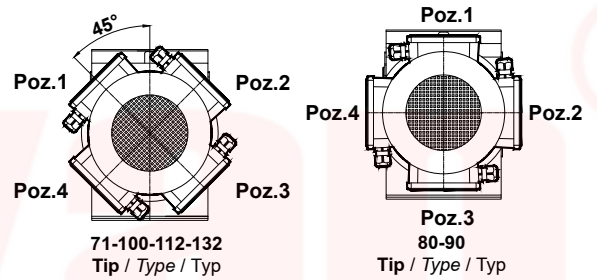

#### KR373.01

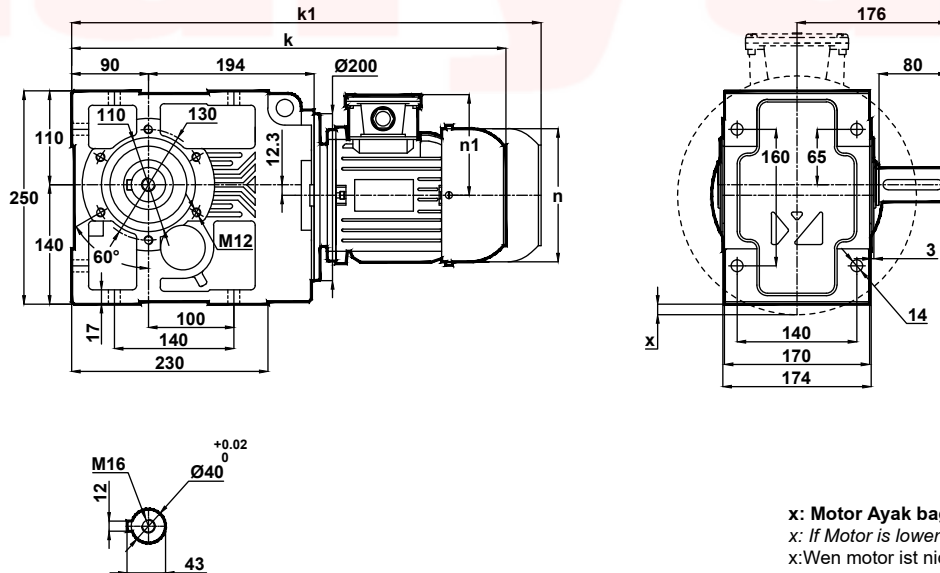

x: Motor Ayak bağlantı yüzeyinin altında ise  
x: If Motor is lower then foot mounting plane  
x:Wen motor ist nidriger den die Anschlußplatte

	71	80	90S	90L	100L	112M	132S	132M
k	487	515	544	569	609	632	686	724
k1	607	635	669	694	744	767	831	869
n	138	156	176	176	194	218	258	258
n1	110	118	126	126	135	146	168	168
x	-	-	-	-	-	-	1.3	1.3







# Ölçü Sayfaları Dimension Pages Abmessungsseiten



-Mil ucu çekirme deliği DIN 332 sayfa 2 / Tapped center hole to DIN 332, sheet 2 / Zentrierung mit gewinde DIN 332, Blatt 2

## KR373.04

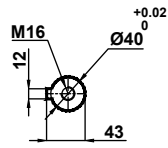
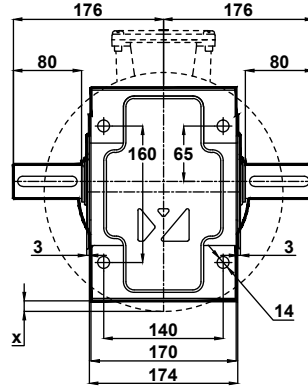
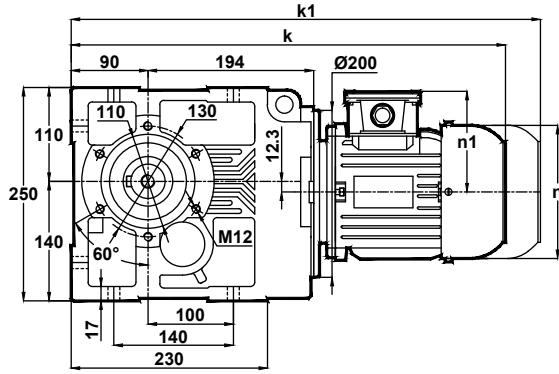

x: Motor Ayak bağlantı yüzeyinin altında ise  
x: If Motor is lower then foot mounting plane  
x: Wenn motor ist niedriger den die Anschlußplatte

**Klemens Pozisyonları**  
Terminal Box Positions  
Klemmenkasten Positionen

	71	80	90S	90L	100L	112M	132S	132M
k	487	515	544	569	609	632	686	724
k1	607	635	669	694	744	767	831	869
n	138	156	176	176	194	218	258	258
n1	110	118	126	126	135	146	168	168
x	-	-	-	-	-	-	1.3	1.3

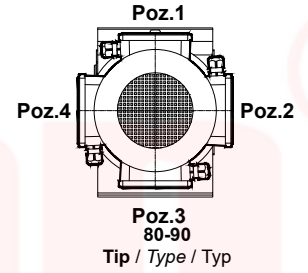
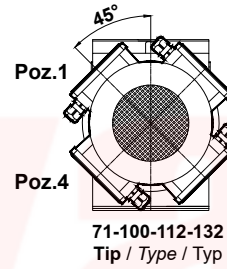

## KR373.05

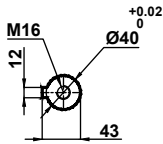
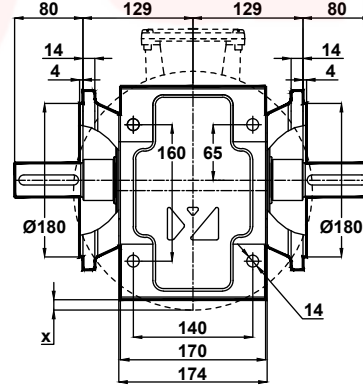
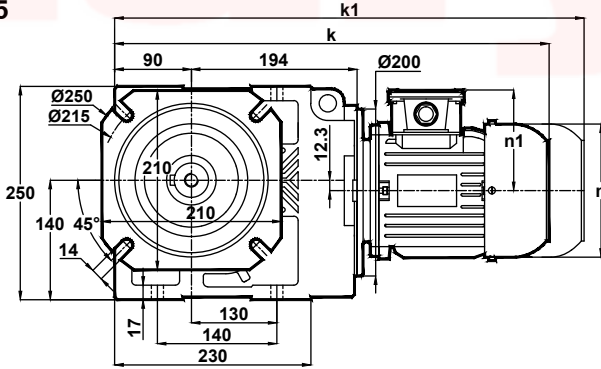

x: Motor Ayak bağlantı yüzeyinin altında ise  
x: If Motor is lower then foot mounting plane  
x: Wenn motor ist niedriger den die Anschlußplatte

	71	80	90S	90L	100L	112M	132S	132M
k	487	515	544	569	609	632	686	724
k1	607	635	669	694	744	767	831	869
n	138	156	176	176	194	218	258	258
n1	110	118	126	126	135	146	168	168
x	-	-	-	-	-	-	1.3	1.3



# Ölçü Sayfaları Dimension Pages Abmessungsseiten



-Mil ucu çektirme deliği DIN 332 sayfa 2 / Tapped center hole to DIN 332, sheet 2 / Zentrierung mit gewinde DIN 332, Blatt 2

KR373.08

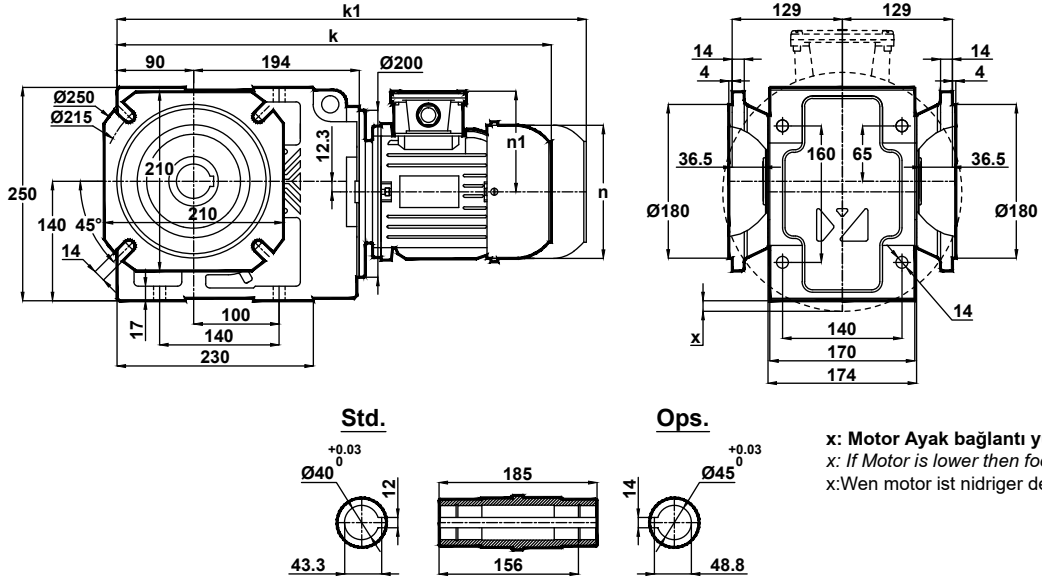

x: Motor Ayak bağlantı yüzeyinin altında ise  
x: If Motor is lower then foot mounting plane  
x: Wenn motor ist niedriger den die Anschlussplatte

Klemens Pozisyonları  
Terminal Box Positions  
Klemmenkasten Positionen

	71	80	90S	90L	100L	112M	132S	132M
k	487	515	544	569	609	632	686	724
k1	607	635	669	694	744	767	831	869
n	138	156	176	176	194	218	258	258
n1	110	118	126	126	135	146	168	168
x	-	-	-	-	-	-	1.3	1.3

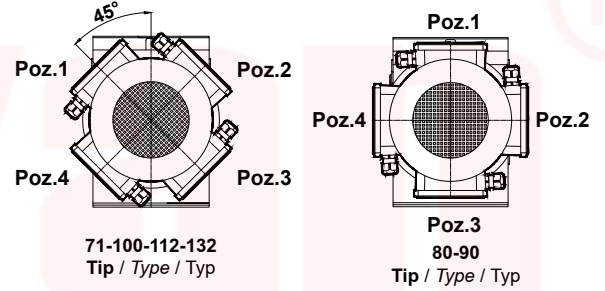



# Ölçü Sayfaları Dimension Pages Abmessungsseiten



-Mil ucu çekirme deliği DIN 332 sayfa 2 / Tapped center hole to DIN 332, sheet 2 / Zentrierung mit gewinde DIN 332, Blatt 2

## KR374.00

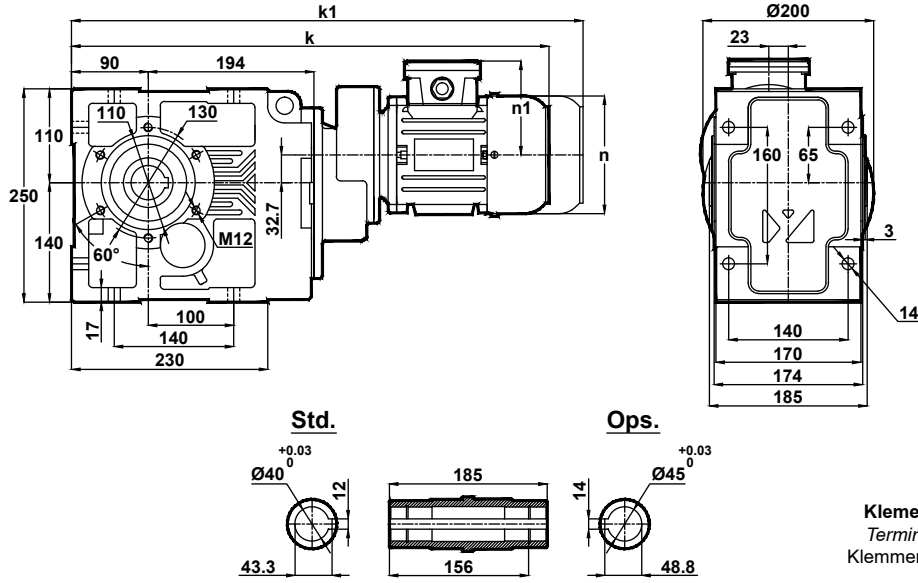

**Klemens Pozisyonları**  
Terminal Box Positions  
Klemmenkasten Positionen

	63	71	80	90S	90L	100L	112M
k	547	566	594	622	647	691	711
k1	-	686	714	747	772	826	846
n	116	138	156	176	176	194	218
n1	97	110	118	126	126	135	146

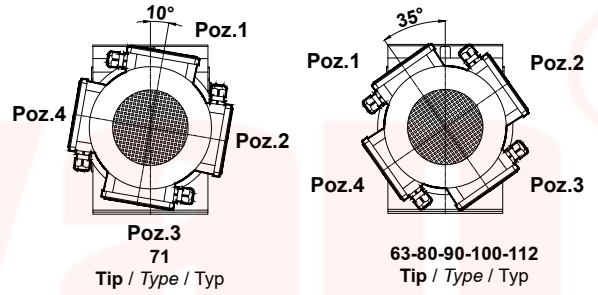

## KR374.01

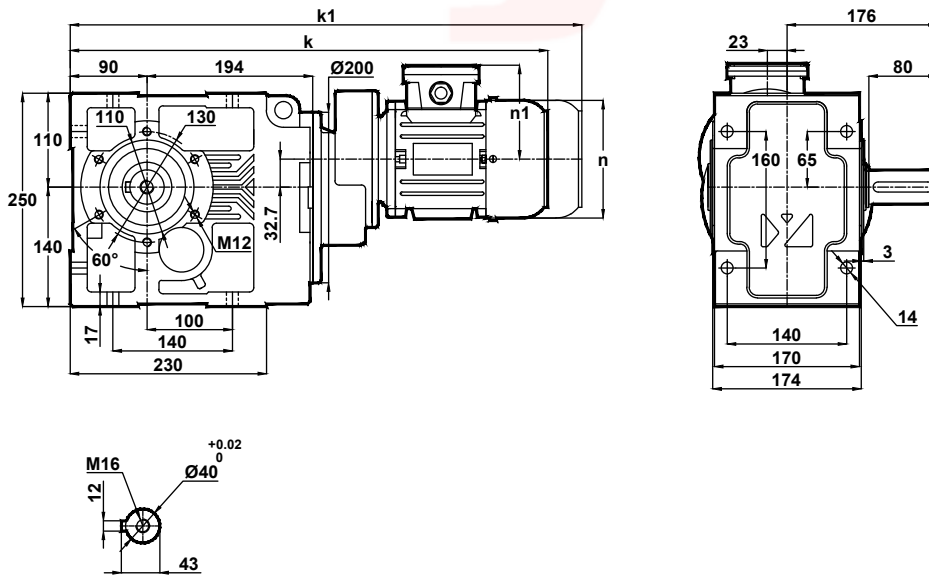

	63	71	80	90S	90L	100L	112M
k	547	566	594	622	647	691	711
k1	-	686	714	747	772	826	846
n	116	138	156	176	176	194	218
n1	97	110	118	126	126	135	146



# Ölçü Sayfaları Dimension Pages Abmessungsseiten



-Mil ucu çektirme deliği DIN 332 sayfa 2 / Tapped center hole to DIN 332, sheet 2 / Zentrierung mit gewinde DIN 332, Blatt 2

## KR374.02

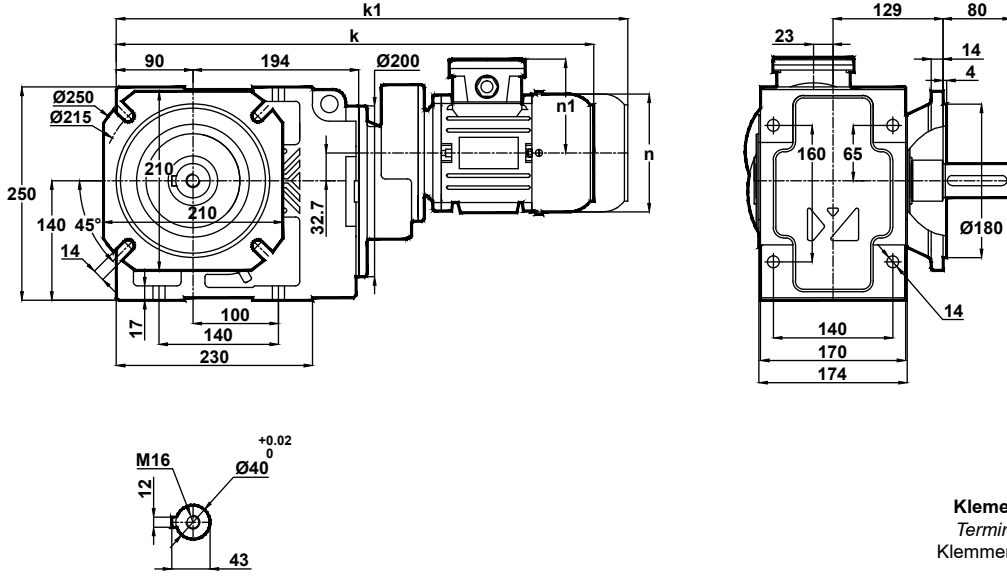

	63	71	80	90S	90L	100L	112M
k	547	566	594	622	647	691	711
k1	-	686	714	747	772	826	846
n	116	138	156	176	176	194	218
n1	97	110	118	126	126	135	146

Klemens Pozisyonları  
Terminal Box Positions  
Klemmenkasten Positionen

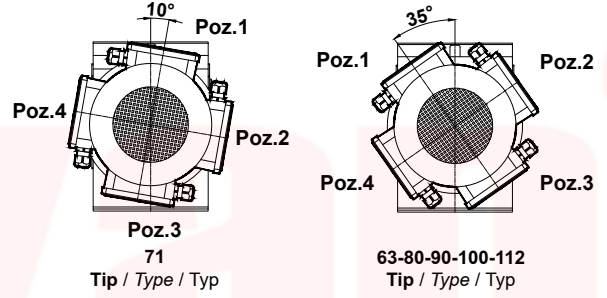

## KR374.03

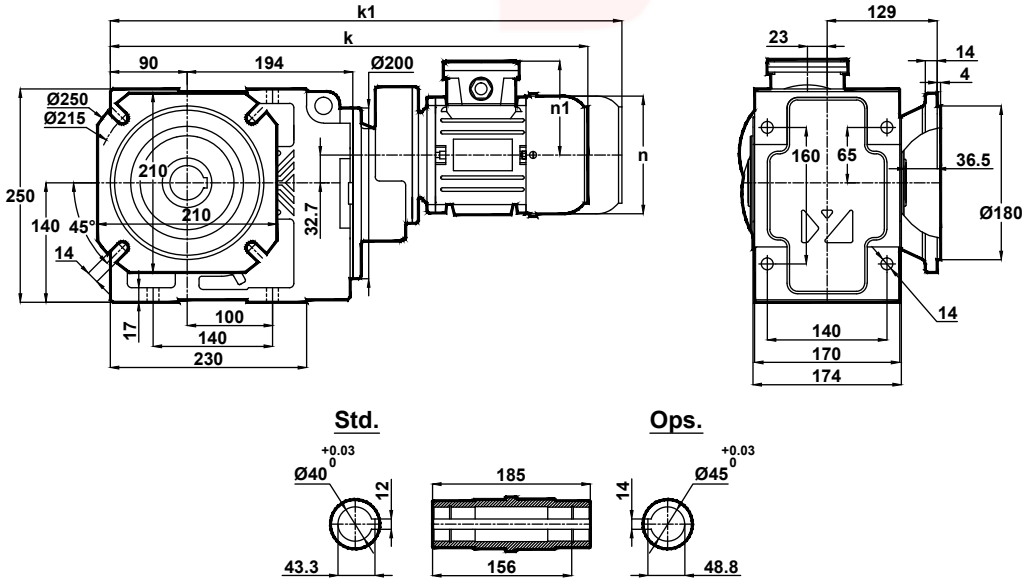

	63	71	80	90S	90L	100L	112M
k	547	566	594	622	647	691	711
k1	-	686	714	747	772	826	846
n	116	138	156	176	176	194	218
n1	97	110	118	126	126	135	146



# Ölçü Sayfaları Dimension Pages Abmessungenseiten



-Mil ucu çekirme deliği DIN 332 sayfa 2 / Tapped center hole to DIN 332, sheet 2 / Zentrierung mit gewinde DIN 332, Blatt 2

## KR374.04

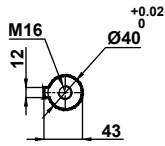
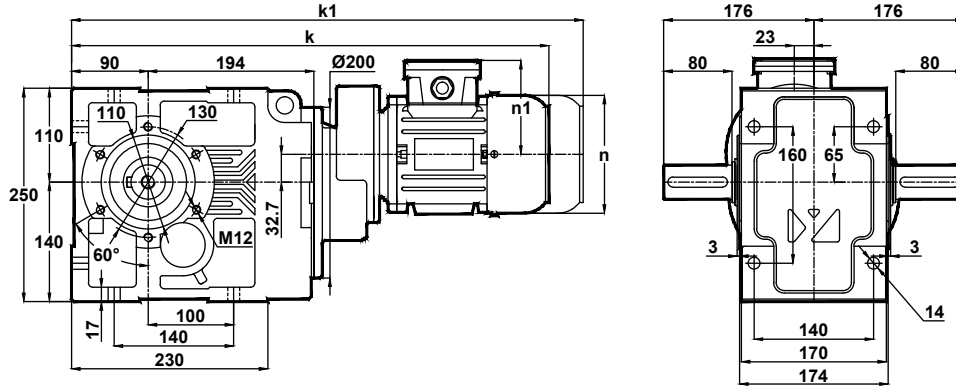

	63	71	80	90S	90L	100L	112M
k	547	566	594	622	647	691	711
k1	-	686	714	747	772	826	846
n	116	138	156	176	176	194	218
n1	97	110	118	126	126	135	146

Klemens Pozisyonları  
Terminal Box Positions  
Klemmenkasten Positionen

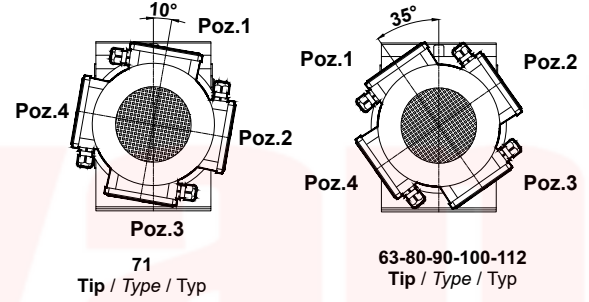

## KR374.05

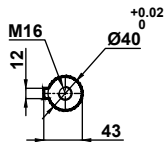
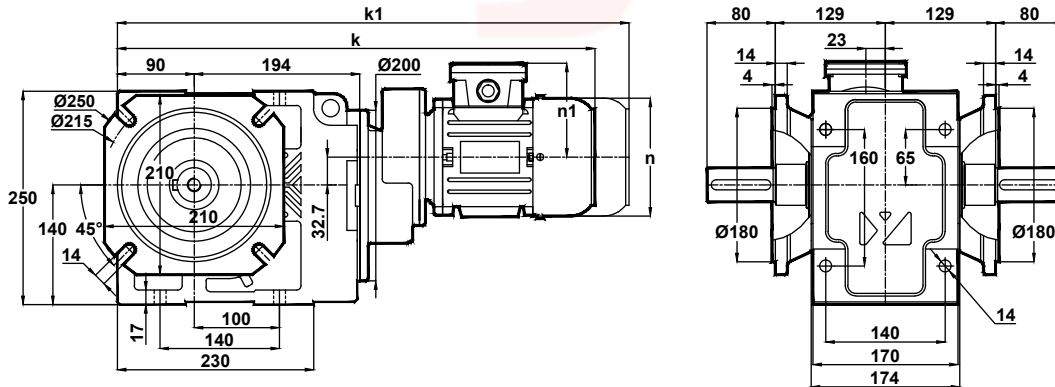

	63	71	80	90S	90L	100L	112M
k	547	566	594	622	647	691	711
k1	-	686	714	747	772	826	846
n	116	138	156	176	176	194	218
n1	97	110	118	126	126	135	146



# Ölçü Sayfaları Dimension Pages Abmessungsseiten



-Mil ucu çektirme deliği DIN 332 sayfa 2 / Tapped center hole to DIN 332, sheet 2 / Zentrierung mit gewinde DIN 332, Blatt 2

KR374.08

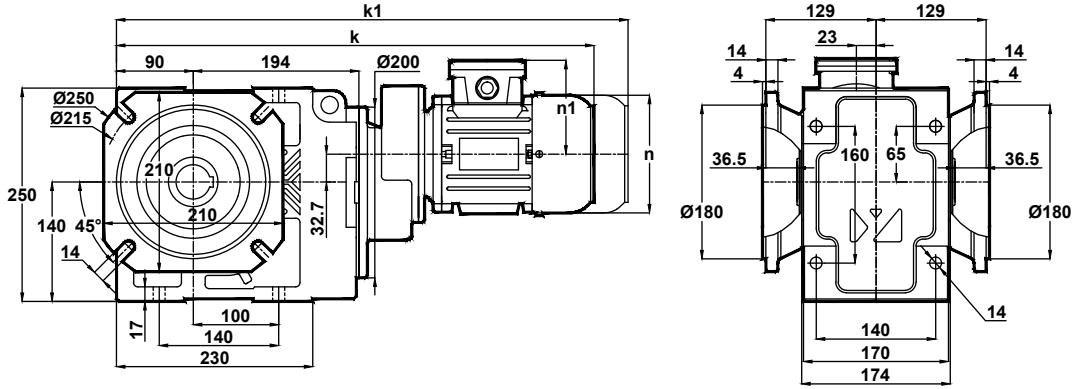

Std.

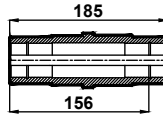
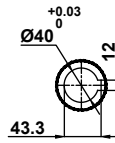

Ops.

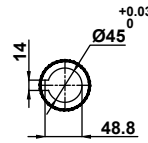

	63	71	80	90S	90L	100L	112M
k	547	566	594	622	647	691	711
k1	-	686	714	747	772	826	846
n	116	138	156	176	176	194	218
n1	97	110	118	126	126	135	146

Klemens Pozisyonları  
Terminal Box Positions  
Klemmenkasten Positionen

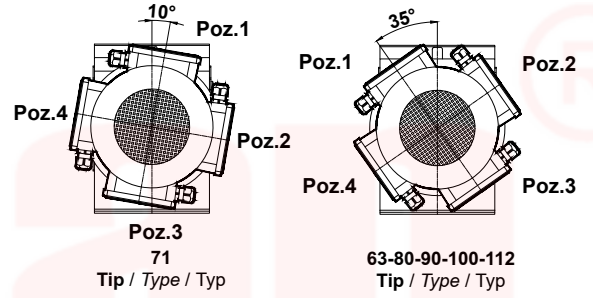



# Ölçü Sayfaları Dimension Pages Abmessungsseiten



-Mil ucu çektirme deliği DIN 332 sayfa 2 / Tapped center hole to DIN 332, sheet 2 / Zentrierung mit gewinde DIN 332, Blatt 2

KR375.00  
KR376.00

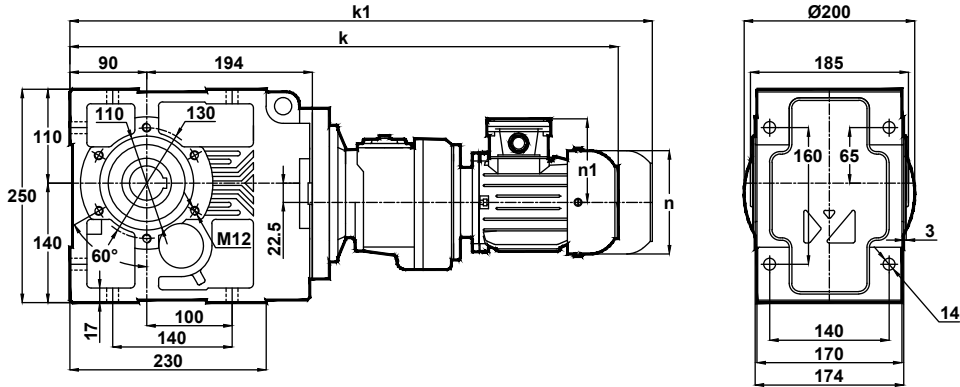

Std.

Ops.

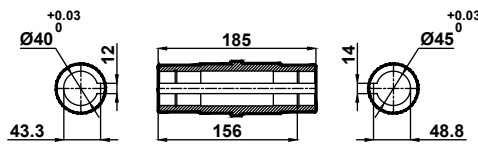

Klemens Pozisyonları  
Terminal Box Positions  
Klemmenkasten Positionen

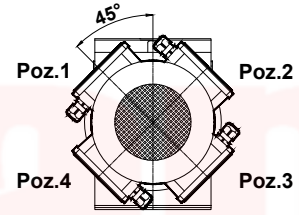

63-71-80-90  
Tip / Type / Typ

	63	71	80	90S	90L
k	647	666	694	722	747
k1	-	786	814	847	872
n	116	138	156	176	176
n1	97	110	118	126	126

KR375.01  
KR376.01

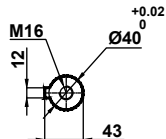
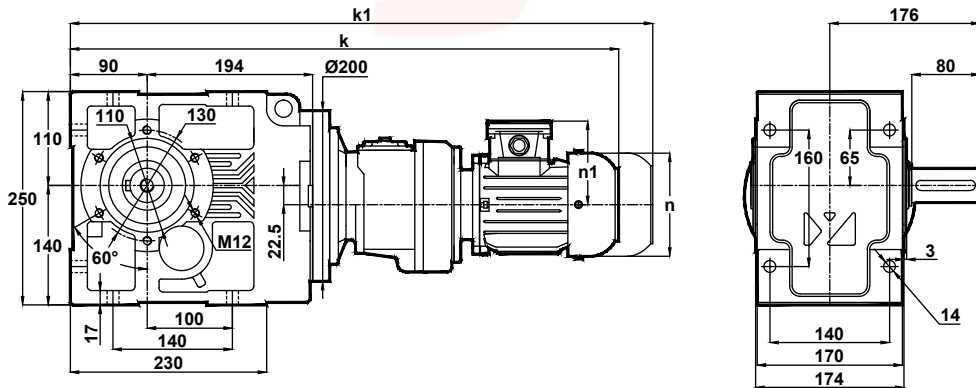

	63	71	80	90S	90L
k	647	666	694	722	747
k1	-	786	814	847	872
n	116	138	156	176	176
n1	97	110	118	126	126





# Ölçü Sayfaları Dimension Pages Abmessungsseiten



-Mil ucu çektirme deliği DIN 332 sayfa 2 / Tapped center hole to DIN 332, sheet 2 / Zentrierung mit gewinde DIN 332, Blatt 2

KR375.02  
KR376.02

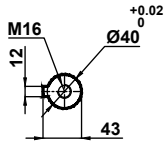
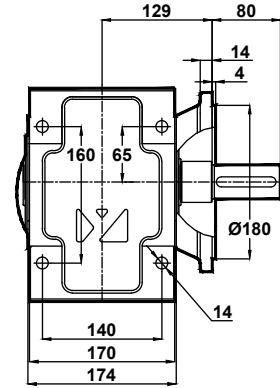
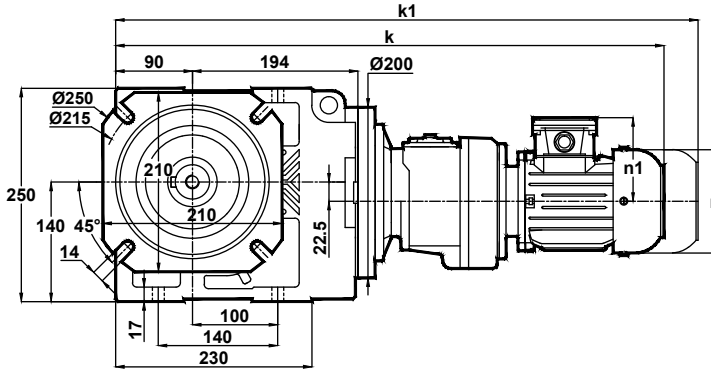

	63	71	80	90S	90L
k	647	666	694	722	747
k1	-	786	814	847	872
n	116	138	156	176	176
n1	97	110	118	126	126

Klemens Pozisyonları  
Terminal Box Positions  
Klemmenkasten Positionen

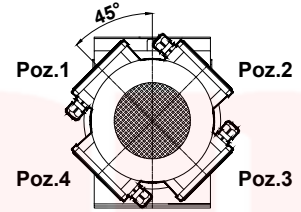

63-71-80-90  
Tip / Type / Typ

KR375.03  
KR376.03

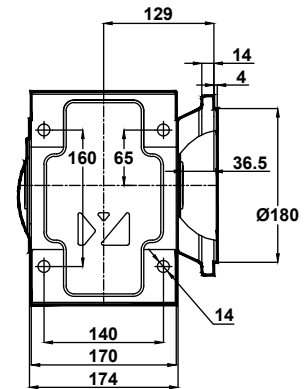
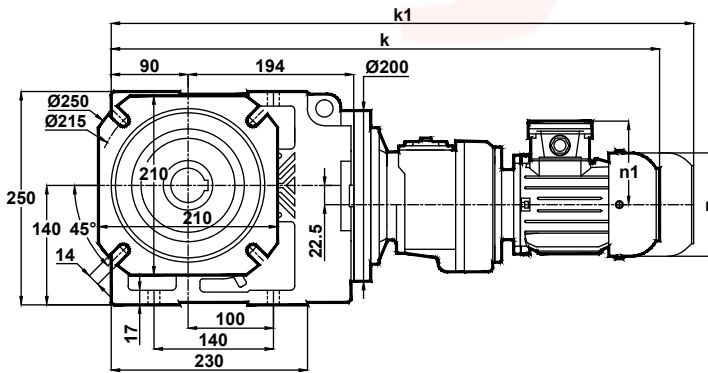

Std.

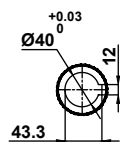

Ops.

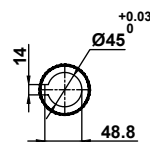
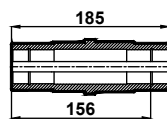

	63	71	80	90S	90L
k	647	666	694	722	747
k1	-	786	814	847	872
n	116	138	156	176	176
n1	97	110	118	126	126



# Ölçü Sayfaları Dimension Pages Abmessungsseiten



-Mil ucu çekirme deliği DIN 332 sayfa 2 / Tapped center hole to DIN 332, sheet 2 / Zentrierung mit gewinde DIN 332, Blatt 2

KR375.04  
KR376.04

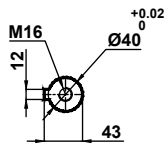
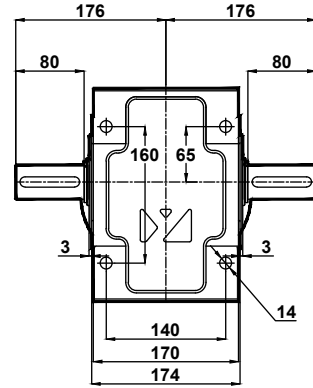
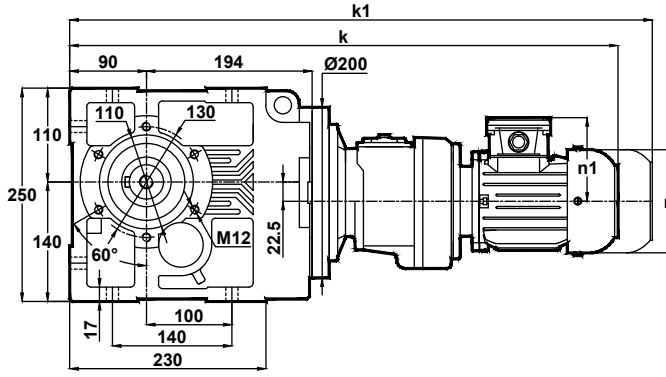

	63	71	80	90S	90L
k	647	666	694	722	747
k1	-	786	814	847	872
n	116	138	156	176	176
n1	97	110	118	126	126

Klemens Pozisyonları  
Terminal Box Positions  
Klemmenkasten Positionen

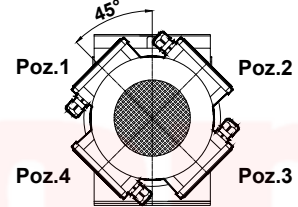

63-71-80-90  
Tip / Type / Typ

KR375.05  
KR376.05

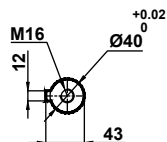
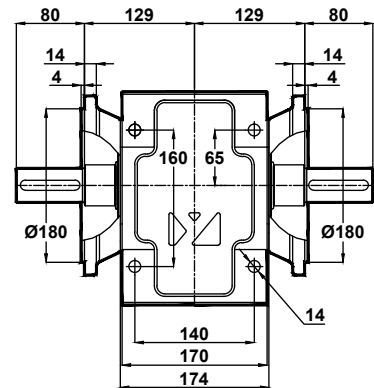
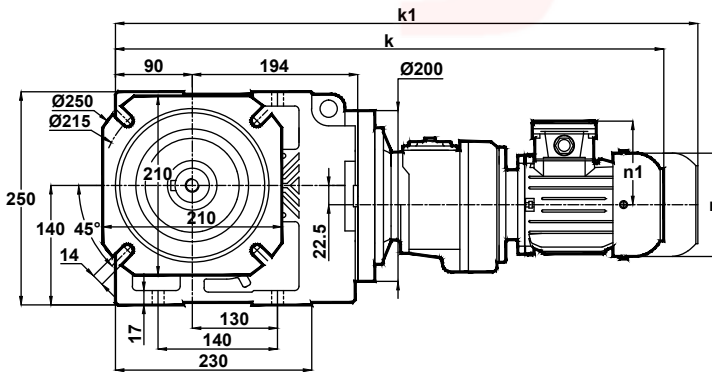

	63	71	80	90S	90L
k	647	666	694	722	747
k1	-	786	814	847	872
n	116	138	156	176	176
n1	97	110	118	126	126



# Ölçü Sayfaları Dimension Pages Abmessungsseiten



-Mil ucu çektirme deliği DIN 332 sayfa 2 / Tapped center hole to DIN 332, sheet 2 / Zentrierung mit gewinde DIN 332, Blatt 2

KR375.08  
KR376.08

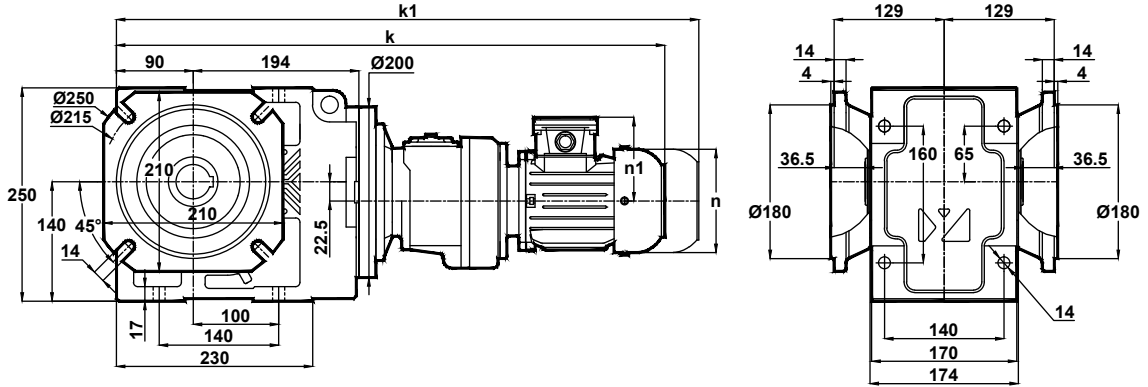

Std.

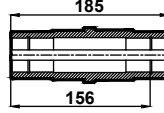
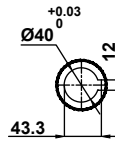

Ops.

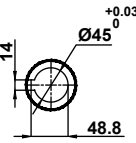

	63	71	80	90S	90L
k	647	666	694	722	747
k1	-	786	814	847	872
n	116	138	156	176	176
n1	97	110	118	126	126

Klemens Pozisyonları  
Terminal Box Positions  
Klemmenkasten Positionen

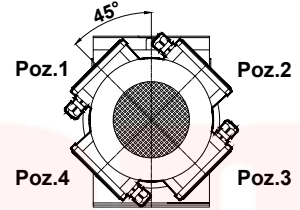

63-71-80-90  
Tip / Type / Typ



# Ölçü Sayfaları

## Dimension Pages

### Abmessungsseiten



-Mil ucu çekirme deliği DIN 332 sayfa 2 / Tapped center hole to DIN 332, sheet 2 / Zentrierung mit gewinde DIN 332, Blatt 2

#### KR473.00

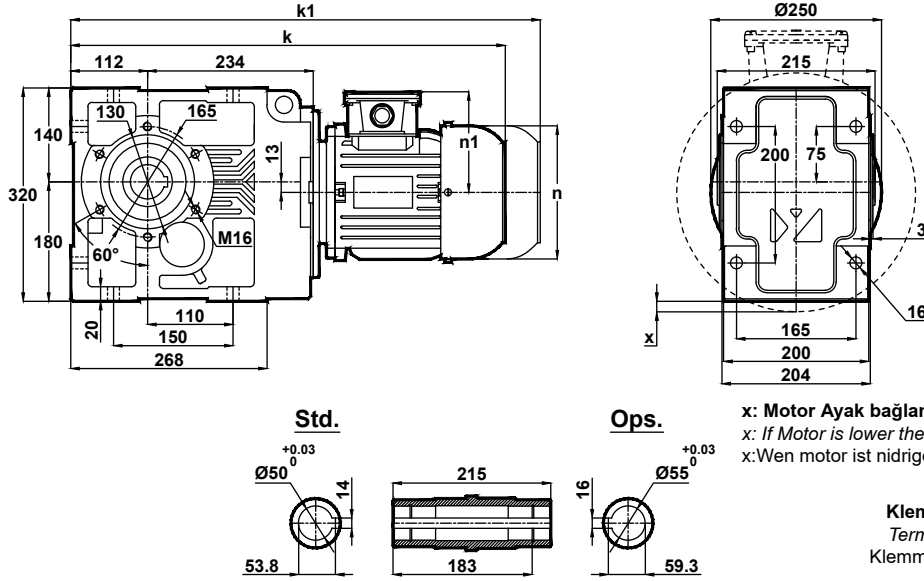

	80	90S	90L	100L	112M	132S	132M	160M	160L	180M	180L
k	572	600	625	663	689	738	776	851	895	912	950
k1	692	725	750	798	824	883	921	1021	1065	1082	1120
n	156	176	176	194	218	258	258	310	310	348	348
n1	118	126	126	135	146	168	168	225	225	241	241
x	-	-	-	-	-	-	-	-	-	7	7

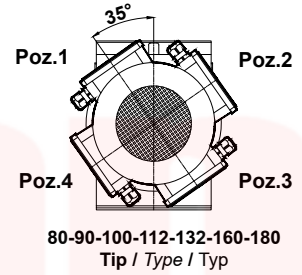

#### KR473.01

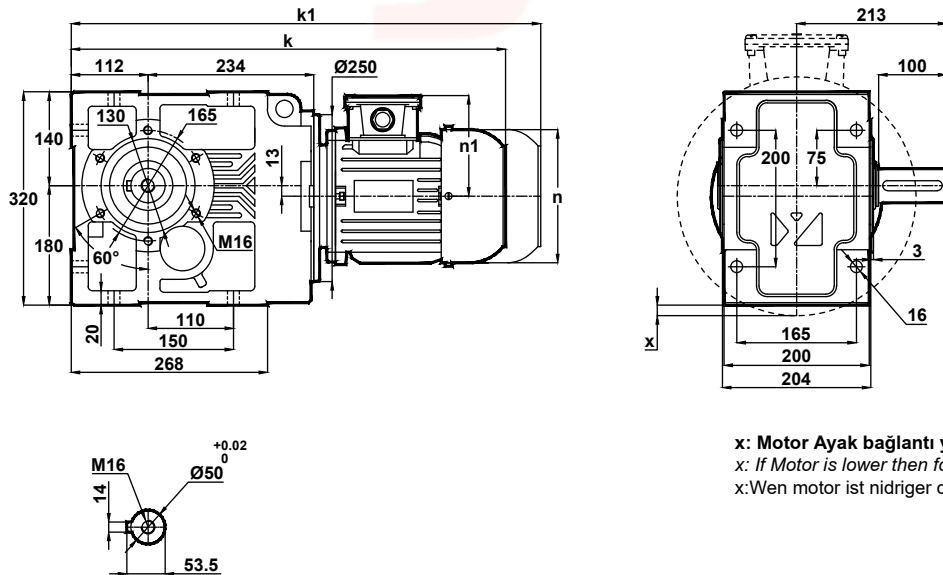

	80	90S	90L	100L	112M	132S	132M	160M	160L	180M	180L
k	572	600	625	663	689	738	776	851	895	912	950
k1	692	725	750	798	824	883	921	1021	1065	1082	1120
n	156	176	176	194	218	258	258	310	310	348	348
n1	118	126	126	135	146	168	168	225	225	241	241
x	-	-	-	-	-	-	-	-	-	7	7



# Ölçü Sayfaları Dimension Pages Abmessungsseiten



-Mil ucu çekirme deliği DIN 332 sayfa 2 / Tapped center hole to DIN 332, sheet 2 / Zentrierung mit gewinde DIN 332, Blatt 2

## KR473.02

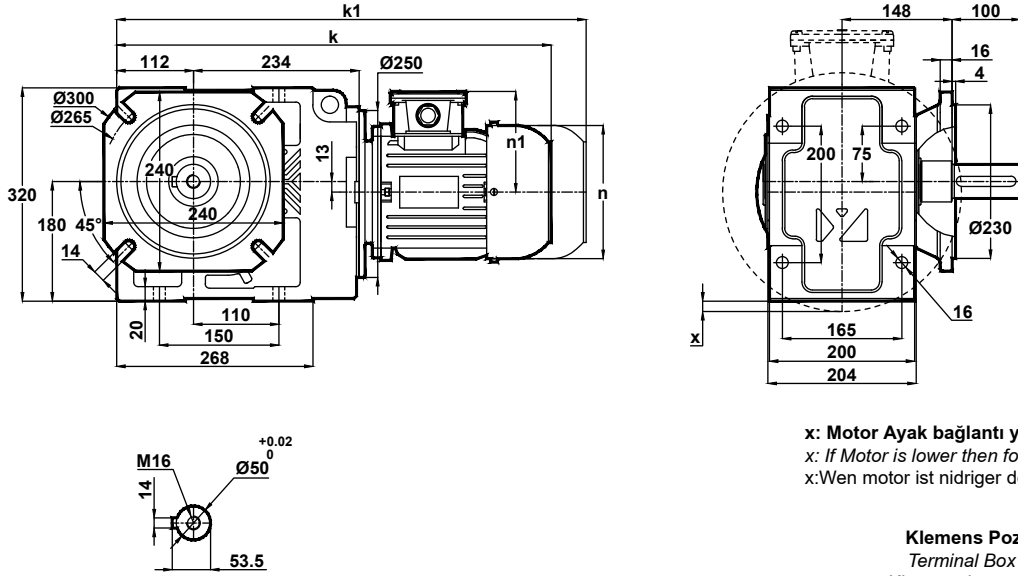

x: Motor Ayak bağlantı yüzeyinin altında ise  
x: If Motor is lower then foot mounting plane  
x: Wenn motor ist niedriger den die Anschlußplatte

**Klemens Pozisyonları**  
Terminal Box Positions  
Klemmenkasten Positionen

	80	90S	90L	100L	112M	132S	132M	160M	160L	180M	180L
k	572	600	625	663	689	738	776	851	895	912	950
k1	692	725	750	798	824	883	921	1021	1065	1082	1120
n	156	176	176	194	218	258	258	310	310	348	348
n1	118	126	126	135	146	168	168	225	225	241	241
x	-	-	-	-	-	-	-	-	-	7	7

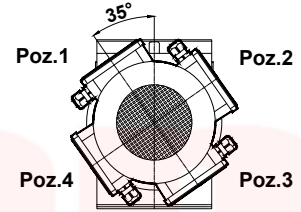

80-90-100-112-132-160-180  
Tip / Type / Typ

## KR473.03

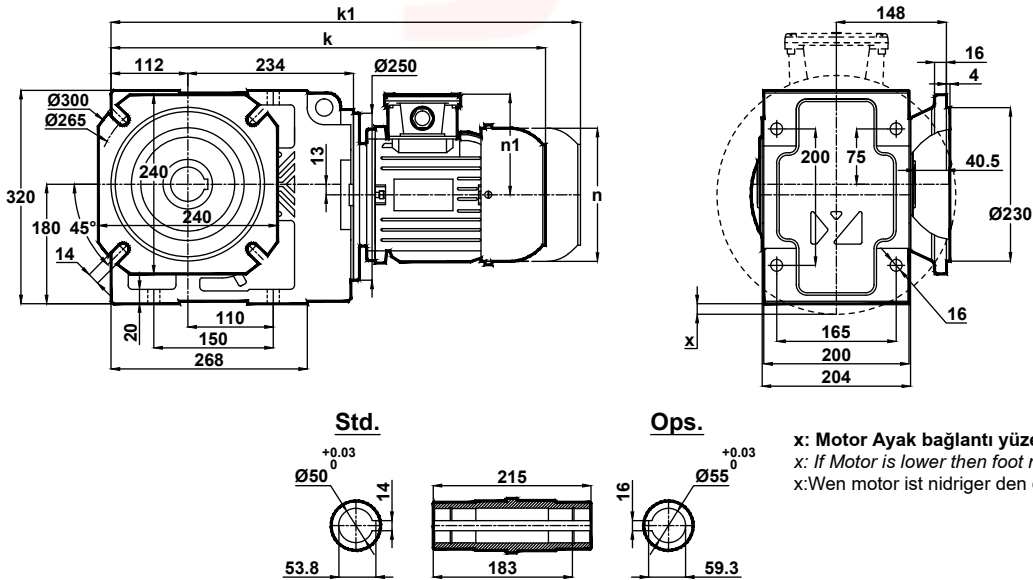

x: Motor Ayak bağlantı yüzeyinin altında ise  
x: If Motor is lower then foot mounting plane  
x: Wenn motor ist niedriger den die Anschlußplatte

	80	90S	90L	100L	112M	132S	132M	160M	160L	180M	180L
k	572	600	625	663	689	738	776	851	895	912	950
k1	692	725	750	798	824	883	921	1021	1065	1082	1120
n	156	176	176	194	218	258	258	310	310	348	348
n1	118	126	126	135	146	168	168	225	225	241	241
x	-	-	-	-	-	-	-	-	-	7	7



# Ölçü Sayfaları Dimension Pages Abmessungsseiten



-Mil ucu çekirme deliği DIN 332 sayfa 2 / Tapped center hole to DIN 332, sheet 2 / Zentrierung mit gewinde DIN 332, Blatt 2

## KR473.04

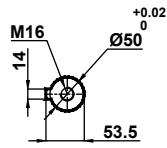
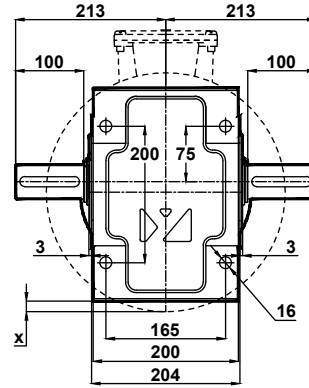
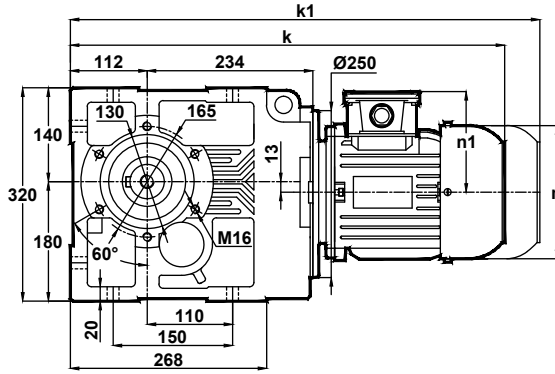

x: Motor Ayak bağlantı yüzeyinin altında ise  
x: If Motor is lower then foot mounting plane  
x: Wenn motor ist niedriger den die Anschlußplatte

Klemens Pozisyonları  
Terminal Box Positions  
Klemmenkasten Positionen

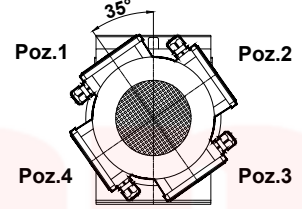

80-90-100-112-132-160-180  
Tip / Type / Typ

	80	90S	90L	100L	112M	132S	132M	160M	160L	180M	180L
k	572	600	625	663	689	738	776	851	895	912	950
k1	692	725	750	798	824	883	921	1021	1065	1082	1120
n	156	176	176	194	218	258	258	310	310	348	348
n1	118	126	126	135	146	168	168	225	225	241	241
x	-	-	-	-	-	-	-	-	-	7	7

## KR473.05

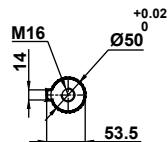
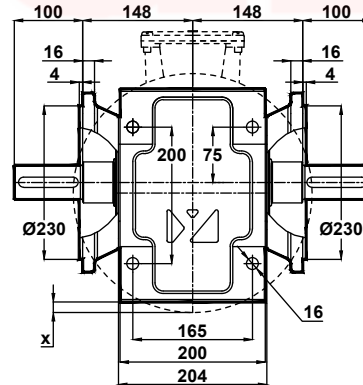
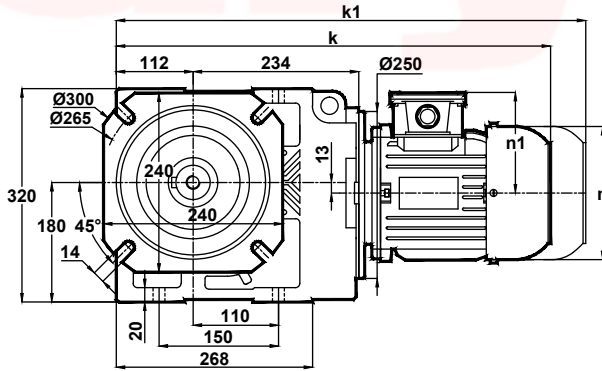

x: Motor Ayak bağlantı yüzeyinin altında ise  
x: If Motor is lower then foot mounting plane  
x: Wenn motor ist niedriger den die Anschlußplatte

	80	90S	90L	100L	112M	132S	132M	160M	160L	180M	180L
k	572	600	625	663	689	738	776	851	895	912	950
k1	692	725	750	798	824	883	921	1021	1065	1082	1120
n	156	176	176	194	218	258	258	310	310	348	348
n1	118	126	126	135	146	168	168	225	225	241	241
x	-	-	-	-	-	-	-	-	-	7	7



# Ölçü Sayfaları Dimension Pages Abmessungsseiten



-Mil ucu çektirme deliği DIN 332 sayfa 2 / Tapped center hole to DIN 332, sheet 2 / Zentrierung mit gewinde DIN 332, Blatt 2

KR473.08

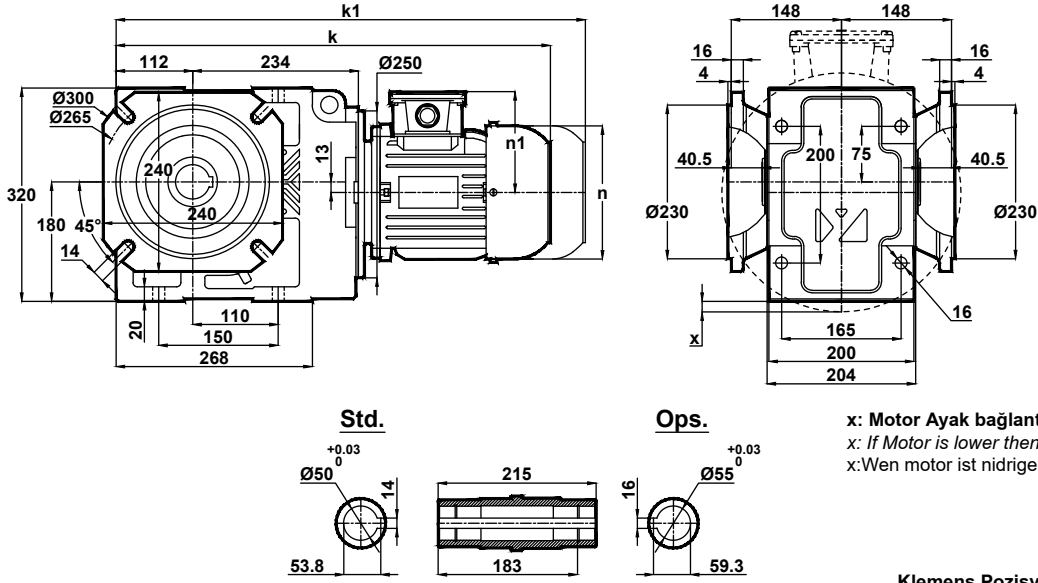

x: Motor Ayak bağlantı yüzeyinin altında ise  
x: If Motor is lower then foot mounting plane  
x: Wenn motor ist niedriger den die Anschlußplatte

	80	90S	90L	100L	112M	132S	132M	160M	160L	180M	180L
k	572	600	625	663	689	738	776	851	895	912	950
k1	692	725	750	798	824	883	921	1021	1065	1082	1120
n	156	176	176	194	218	258	258	310	310	348	348
n1	118	126	126	135	146	168	168	225	225	241	241
x	-	-	-	-	-	-	-	-	-	7	7

Klemens Pozisyonları  
Terminal Box Positions  
Klemmenkasten Positionen

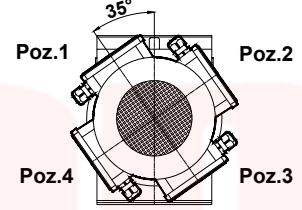

80-90-100-112-132-160-180  
Tip / Type / Typ







# Ölçü Sayfaları Dimension Pages Abmessungsseiten



-Mil ucu çektirme deliği DIN 332 sayfa 2 / Tapped center hole to DIN 332, sheet 2 / Zentrierung mit gewinde DIN 332, Blatt 2

## KR474.02

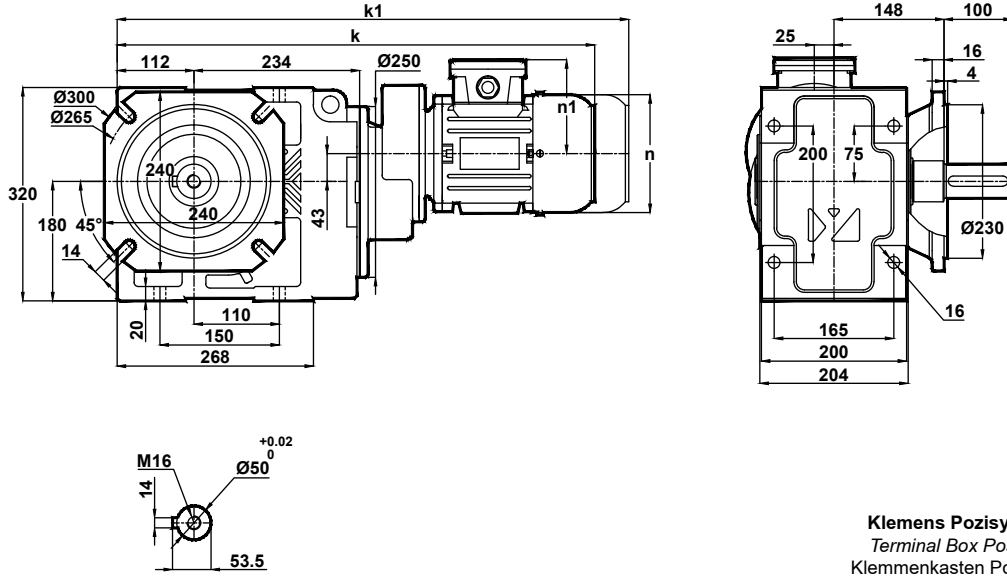

Klemens Pozisyonları  
Terminal Box Positions  
Klemmenkasten Positionen

	71	80	90S	90L	100L	112M	132S	132M
k	637	665	694	719	759	782	836	874
k1	757	785	819	844	894	917	981	1019
n	138	156	176	176	194	218	258	258
n1	110	118	126	126	135	146	168	168

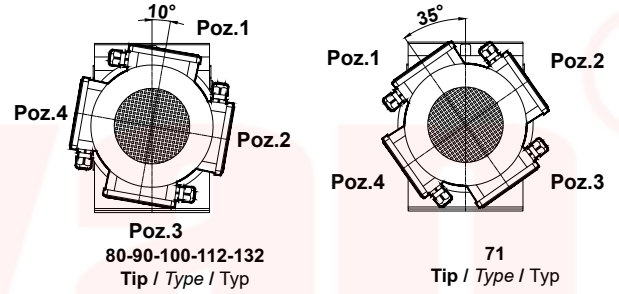

## KR474.03

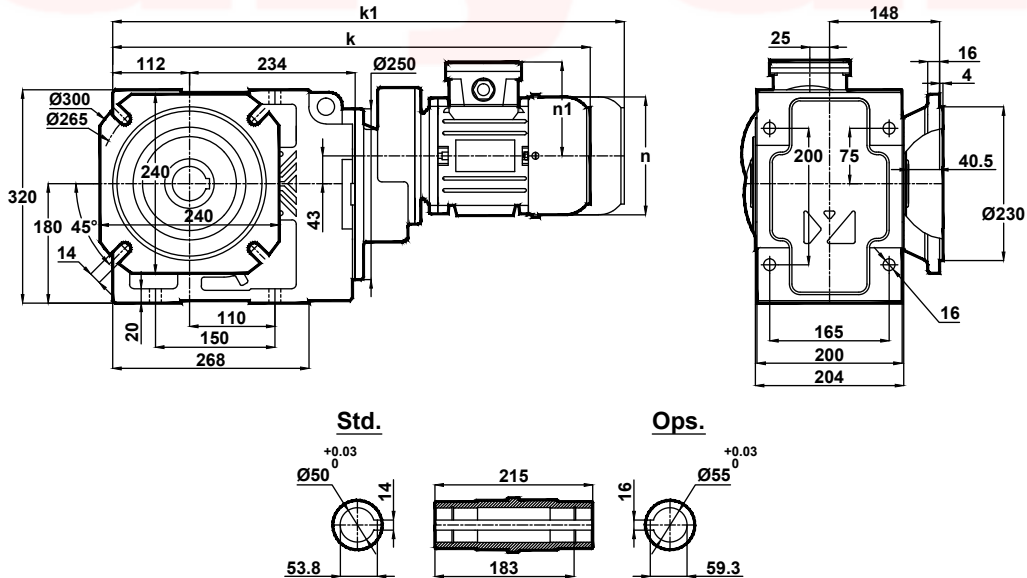

	71	80	90S	90L	100L	112M	132S	132M
k	637	665	694	719	759	782	836	874
k1	757	785	819	844	894	917	981	1019
n	138	156	176	176	194	218	258	258
n1	110	118	126	126	135	146	168	168



# Ölçü Sayfaları Dimension Pages Abmessungenseiten



-Mil ucu çektirme deliği DIN 332 sayfa 2 / Tapped center hole to DIN 332, sheet 2 / Zentrierung mit gewinde DIN 332, Blatt 2

## KR474.04

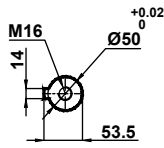
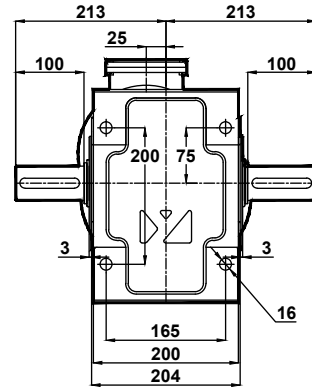
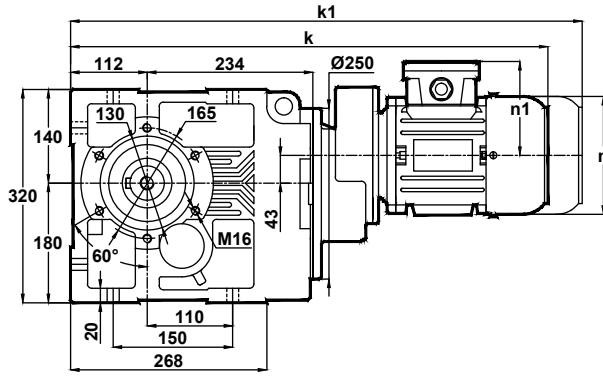

	71	80	90S	90L	100L	112M	132S	132M
k	637	665	694	719	759	782	836	874
k1	757	785	819	844	894	917	981	1019
n	138	156	176	176	194	218	258	258
n1	110	118	126	126	135	146	168	168

### Klemens Pozisyonları Terminal Box Positions Klemmenkasten Positionen

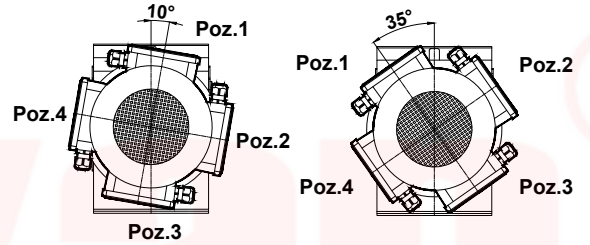

80-90-100-112-132  
Tip / Type / Typ

71  
Tip / Type / Typ

## KR474.05

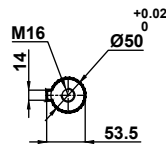
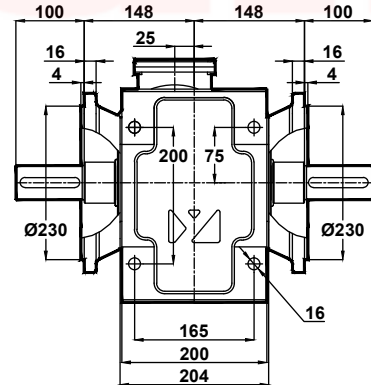
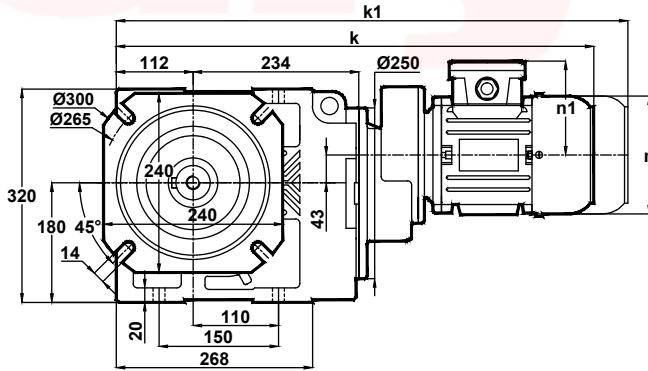

	71	80	90S	90L	100L	112M	132S	132M
k	637	665	694	719	759	782	836	874
k1	757	785	819	844	894	917	981	1019
n	138	156	176	176	194	218	258	258
n1	110	118	126	126	135	146	168	168



# Ölçü Sayfaları Dimension Pages Abmessungsseiten



-Mil ucu çektirme deliği DIN 332 sayfa 2 / Tapped center hole to DIN 332, sheet 2 / Zentrierung mit gewinde DIN 332, Blatt 2

KR474.08

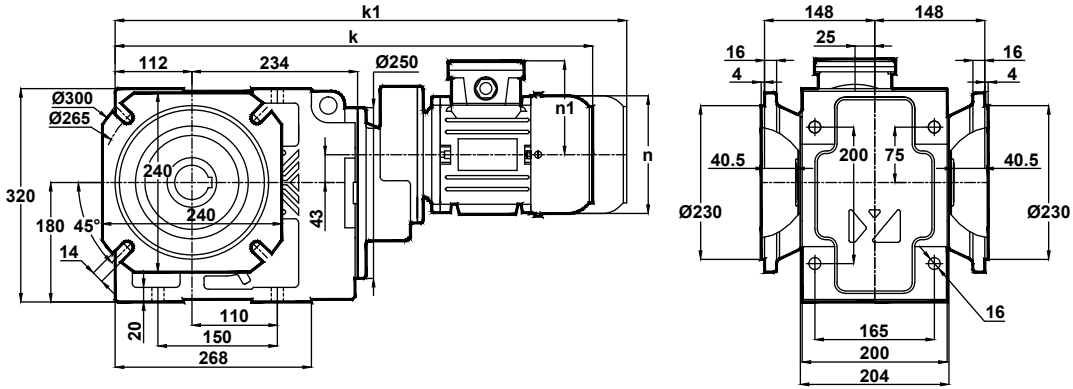

Std.

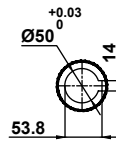

Ops.

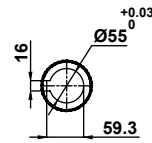

Klemens Pozisyonları  
Terminal Box Positions  
Klemmenkasten Positionen

	71	80	90S	90L	100L	112M	132S	132M
k	637	665	694	719	759	782	836	874
k1	757	785	819	844	894	917	981	1019
n	138	156	176	176	194	218	258	258
n1	110	118	126	126	135	146	168	168

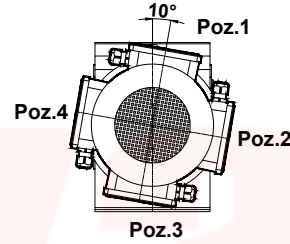

80-90-100-112-132  
Tip / Type / Typ

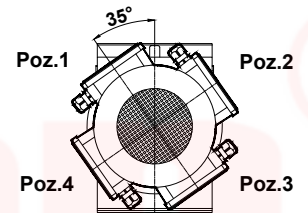

71  
Tip / Type / Typ



# Ölçü Sayfaları Dimension Pages Abmessungenseiten



-Mil ucu çektirme deliği DIN 332 sayfa 2 / Tapped center hole to DIN 332, sheet 2 / Zentrierung mit gewinde DIN 332, Blatt 2

KR475.00  
KR476.00

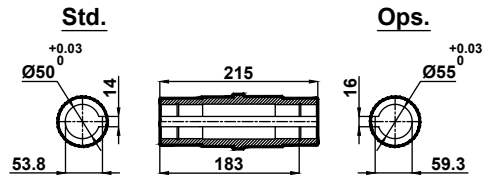
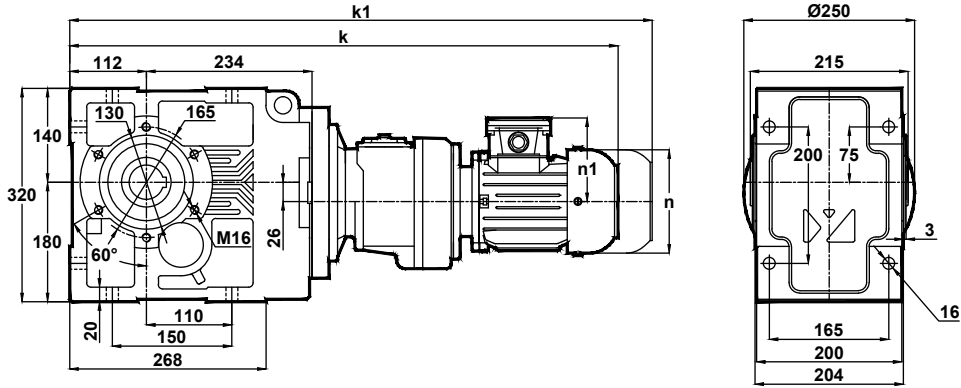

**Klemens Pozisyonları**  
Terminal Box Positions  
Klemmenkasten Positionen

	63	71	80	90S	90L	100L	112M
k	748	767	795	823	848	889	912
k1	-	887	915	948	973	1024	1047
n	116	138	156	176	176	194	194
n1	97	110	118	126	126	135	135

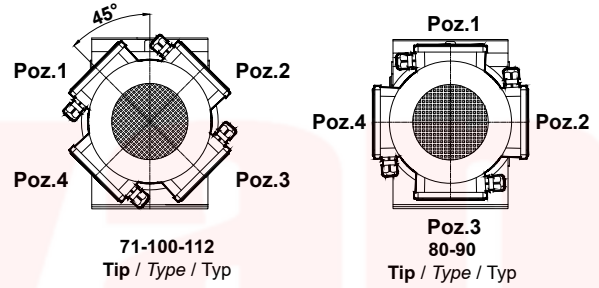

KR475.01  
KR476.01

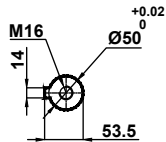
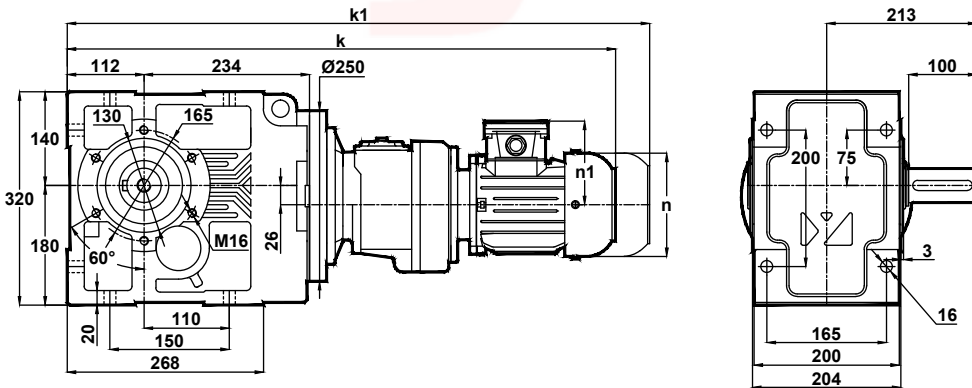

	63	71	80	90S	90L	100L	112M
k	748	767	795	823	848	889	912
k1	-	887	915	948	973	1024	1047
n	116	138	156	176	176	194	194
n1	97	110	118	126	126	135	135



# Ölçü Sayfaları Dimension Pages Abmessungsseiten



-Mil ucu çektirme deliği DIN 332 sayfa 2 / Tapped center hole to DIN 332, sheet 2 / Zentrierung mit gewinde DIN 332, Blatt 2

KR475.02  
KR476.02

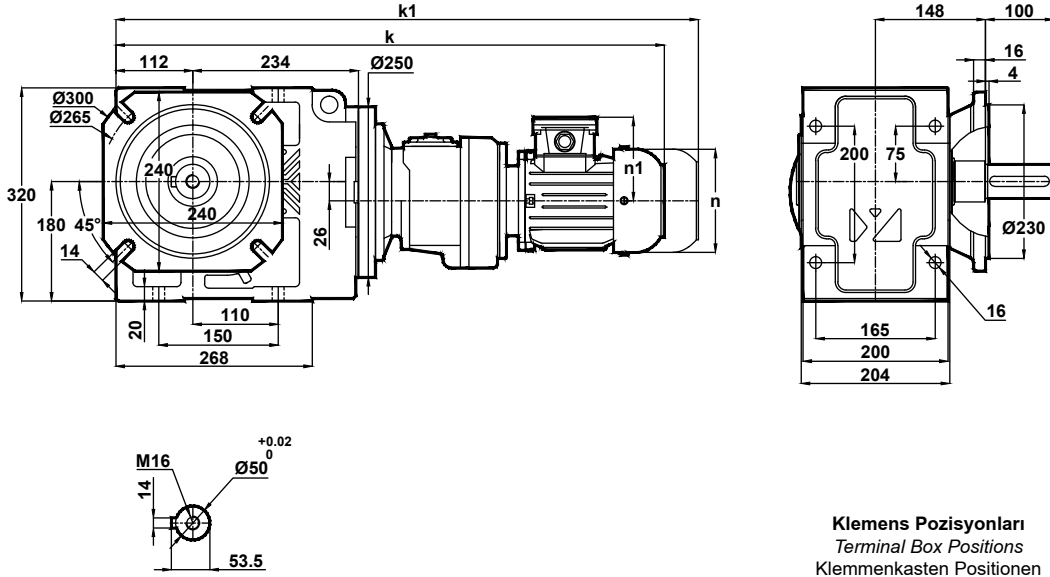

	63	71	80	90S	90L	100L	112M
k	748	767	795	823	848	889	912
k1	-	887	915	948	973	1024	1047
n	116	138	156	176	176	194	194
n1	97	110	118	126	126	135	135

Klemens Pozisyonları  
Terminal Box Positions  
Klemmenkasten Positionen

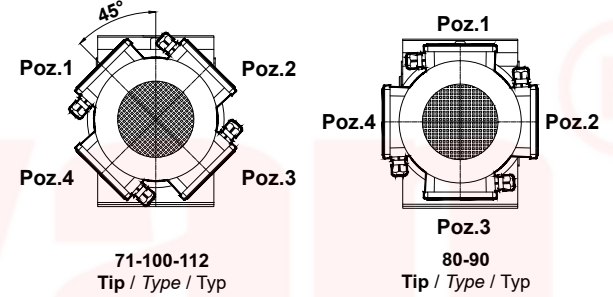

71-100-112  
Tip / Type / Typ

80-90  
Tip / Type / Typ

KR475.03  
KR476.03

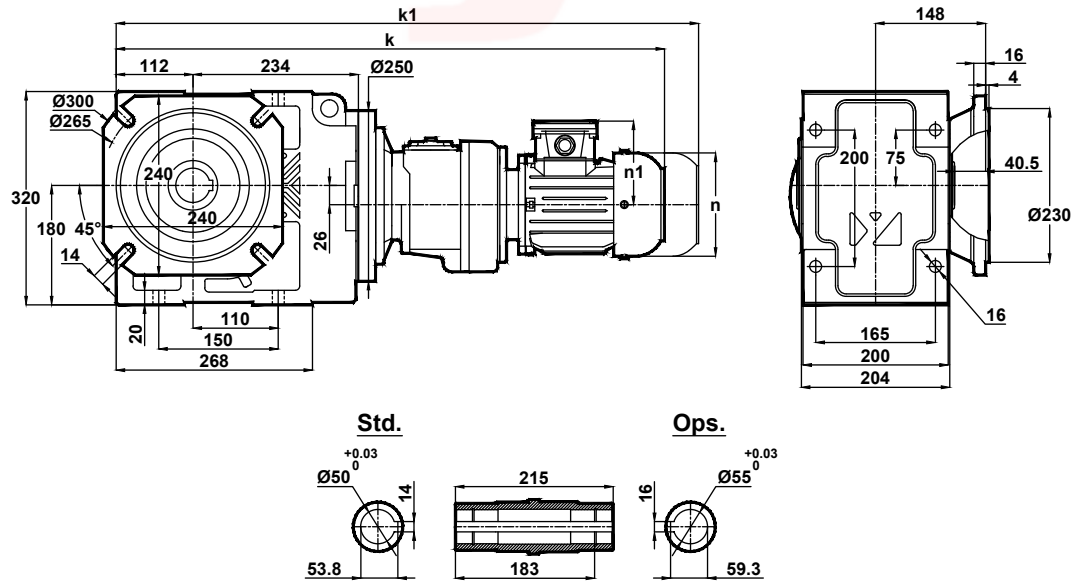

Std.

Ops.

	63	71	80	90S	90L	100L	112M
k	748	767	795	823	848	889	912
k1	-	887	915	948	973	1024	1047
n	116	138	156	176	176	194	194
n1	97	110	118	126	126	135	135



# Ölçü Sayfaları Dimension Pages Abmessungsseiten



-Mil ucu çekirme deliği DIN 332 sayfa 2 / Tapped center hole to DIN 332, sheet 2 / Zentrierung mit gewinde DIN 332, Blatt 2

KR475.04  
KR476.04

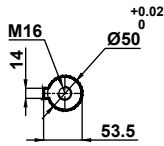
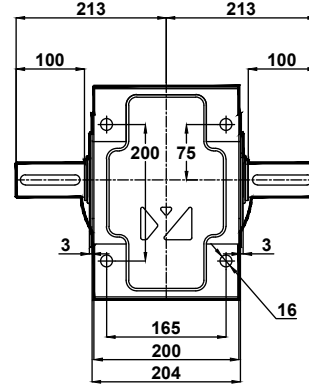
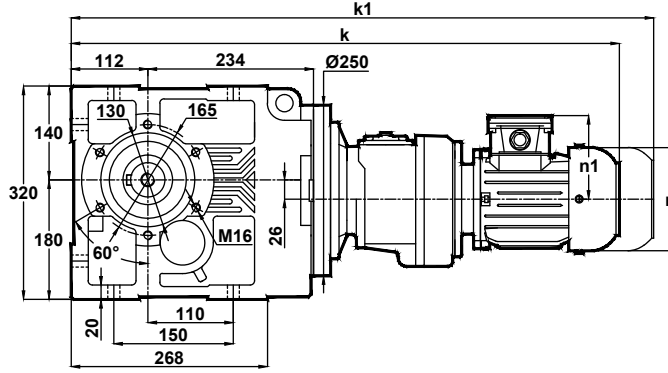

	63	71	80	90S	90L	100L	112M
k	748	767	795	823	848	889	912
k1	-	887	915	948	973	1024	1047
n	116	138	156	176	176	194	194
n1	97	110	118	126	126	135	135

Klemens Pozisyonları  
Terminal Box Positions  
Klemmenkasten Positionen

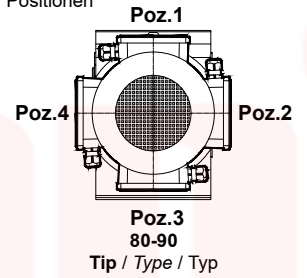
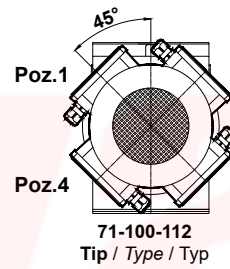

KR475.05  
KR476.05

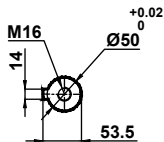
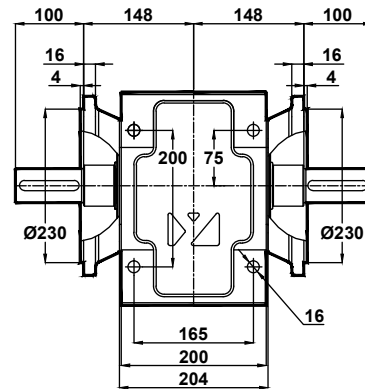
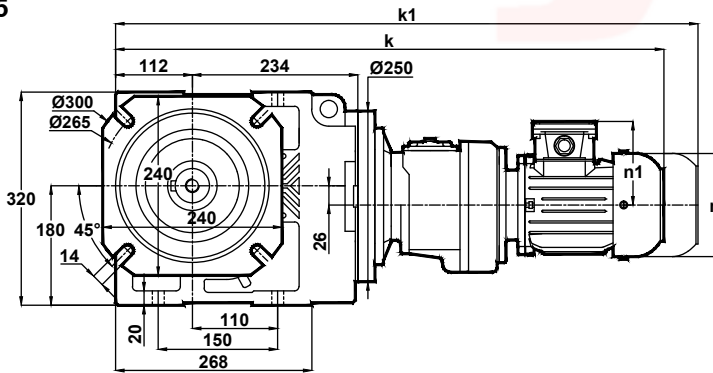

	63	71	80	90S	90L	100L	112M
k	748	767	795	823	848	889	912
k1	-	887	915	948	973	1024	1047
n	116	138	156	176	176	194	194
n1	97	110	118	126	126	135	135



# Ölçü Sayfaları Dimension Pages Abmessungsseiten



-Mil ucu çekirme deliği DIN 332 sayfa 2 / Tapped center hole to DIN 332, sheet 2 / Zentrierung mit gewinde DIN 332, Blatt 2

KR475.08  
KR476.08

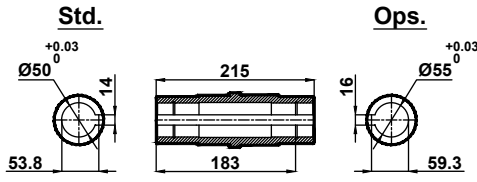
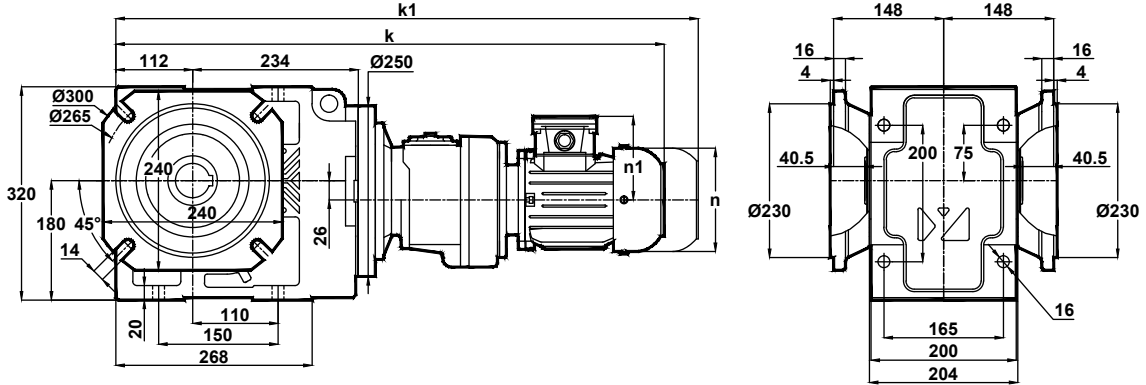

Klemens Pozisyonları  
Terminal Box Positions  
Klemmenkasten Positionen

	63	71	80	90S	90L	100L	112M
k	748	767	795	823	848	889	912
k1	-	887	915	948	973	1024	1047
n	116	138	156	176	176	194	194
n1	97	110	118	126	126	135	135

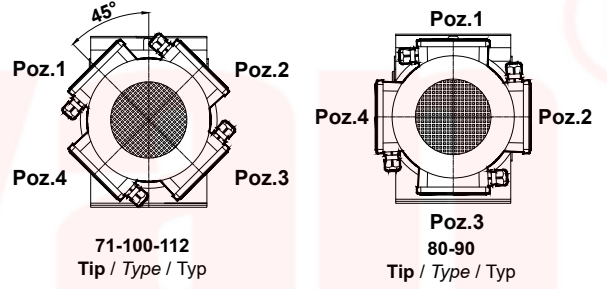



# Ölçü Sayfaları Dimension Pages Abmessungsseiten



-Mil ucu çekirme deliği DIN 332 sayfa 2 / Tapped center hole to DIN 332, sheet 2 / Zentrierung mit gewinde DIN 332, Blatt 2

## KR573.00

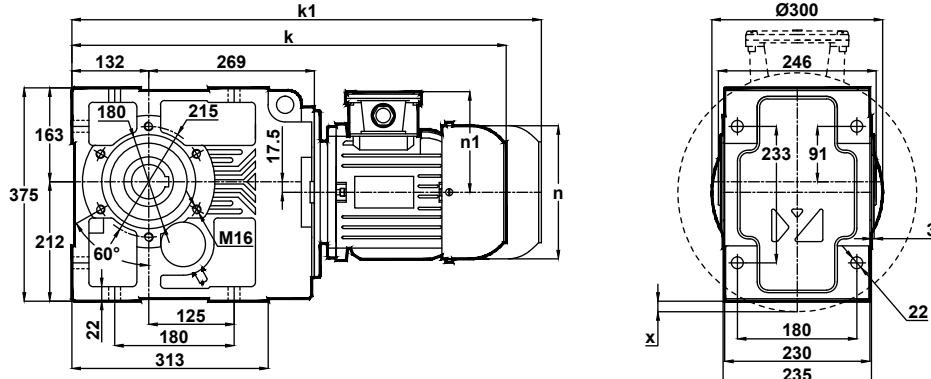

**Std.**

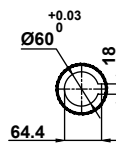

**Ops.**

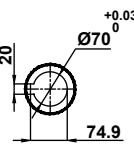

x: Motor Ayak bağlantı yüzeyinin altında ise  
x: If Motor is lower then foot mounting plane  
x: Wenn motor ist niedriger den die Anschlußplatte

**Klemens Pozisyonları**  
Terminal Box Positions  
Klemmenkasten Positionen

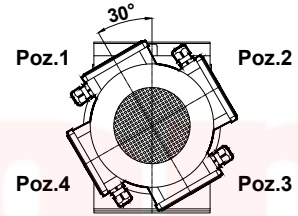

100-112-132-160-180-200  
Tip / Type / Typ

	100L	112M	132S	132M	160M	160L	180M	180L	200L
k	711.5	734.5	788.5	826.5	901.5	945.5	962	1000	1039
k1	846.5	869.5	933.5	971.5	1071.5	115.5	1132	1170	1239
n	194	218	258	258	310	310	348	348	390
n1	135	146	168	168	225	225	241	241	275
x	-	-	-	-	-	-	-	-	0.5

## KR573.01

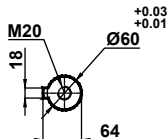
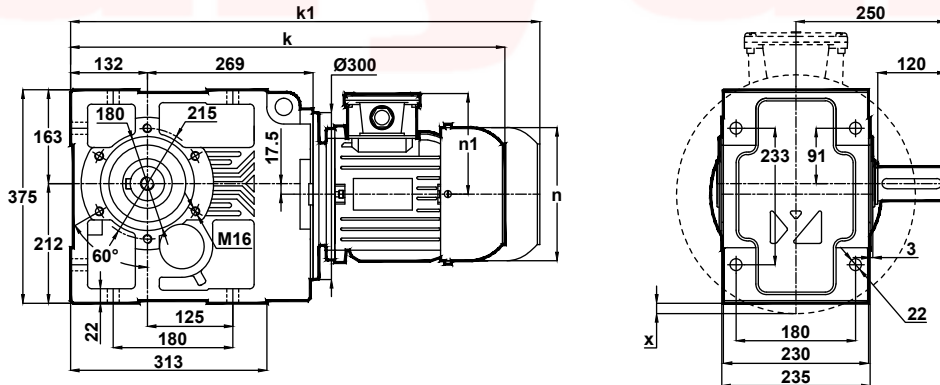

x: Motor Ayak bağlantı yüzeyinin altında ise  
x: If Motor is lower then foot mounting plane  
x: Wenn motor ist niedriger den die Anschlußplatte

	100L	112M	132S	132M	160M	160L	180M	180L	200L
k	711.5	734.5	788.5	826.5	901.5	945.5	962	1000	1039
k1	846.5	869.5	933.5	971.5	1071.5	115.5	1132	1170	1239
n	194	218	258	258	310	310	348	348	390
n1	135	146	168	168	225	225	241	241	275
x	-	-	-	-	-	-	-	-	0.5





# Ölçü Sayfaları Dimension Pages Abmessungsseiten



-Mil ucu çektirme deliği DIN 332 sayfa 2 / Tapped center hole to DIN 332, sheet 2 / Zentrierung mit gewinde DIN 332, Blatt 2

## KR573.02

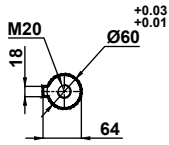
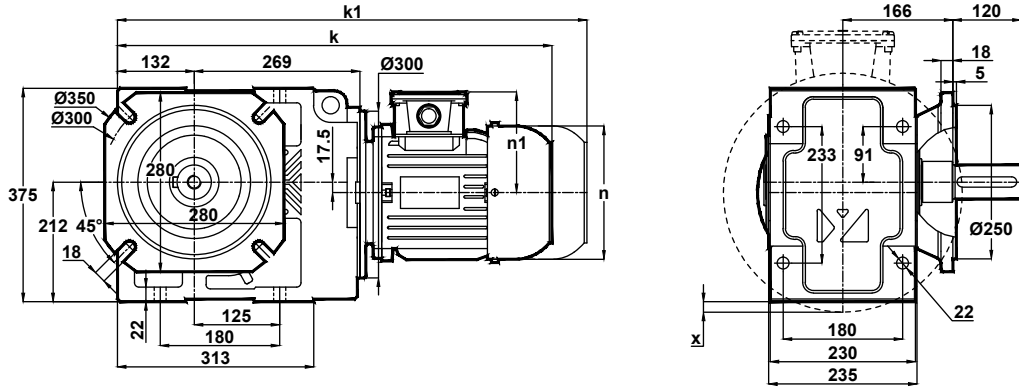

x: Motor Ayak bağlantı yüzeyinin altında ise  
x: If Motor is lower then foot mounting plane  
x: Wenn motor ist niedriger den die Anschlußplatte

**Klemens Pozisyonları**  
Terminal Box Positions  
Klemmenkasten Positionen

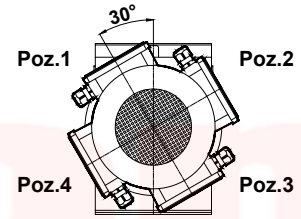

100-112-132-160-180-200  
Tip / Type / Typ

	100L	112M	132S	132M	160M	160L	180M	180L	200L
k	711.5	734.5	788.5	826.5	901.5	945.5	962	1000	1039
k1	846.5	869.5	933.5	971.5	1071.5	115.5	1132	1170	1239
n	194	218	258	258	310	310	348	348	390
n1	135	146	168	168	225	225	241	241	275
x	-	-	-	-	-	-	-	-	0.5

## KR573.03

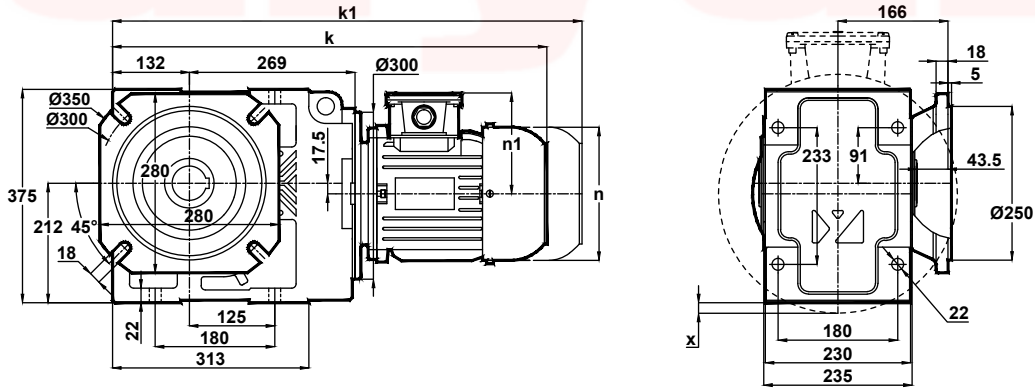

**Std.**

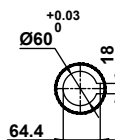

**Ops.**

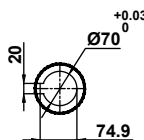

x: Motor Ayak bağlantı yüzeyinin altında ise  
x: If Motor is lower then foot mounting plane  
x: Wenn motor ist niedriger den die Anschlußplatte

	100L	112M	132S	132M	160M	160L	180M	180L	200L
k	711.5	734.5	788.5	826.5	901.5	945.5	962	1000	1039
k1	846.5	869.5	933.5	971.5	1071.5	115.5	1132	1170	1239
n	194	218	258	258	310	310	348	348	390
n1	135	146	168	168	225	225	241	241	275
x	-	-	-	-	-	-	-	-	0.5



# Ölçü Sayfaları Dimension Pages Abmessungsseiten



-Mil ucu çekirme deliği DIN 332 sayfa 2 / Tapped center hole to DIN 332, sheet 2 / Zentrierung mit gewinde DIN 332, Blatt 2

## KR573.04

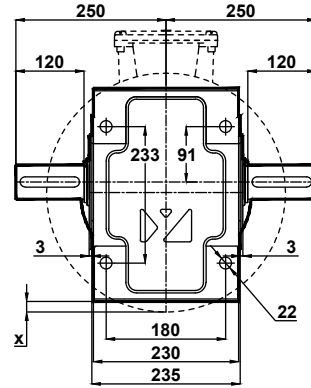
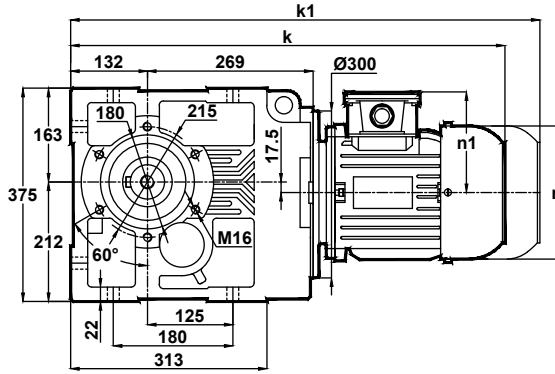

x: Motor Ayak bağlantı yüzeyinin altında ise  
x: If Motor is lower then foot mounting plane  
x: Wenn motor ist niedriger den die Anschlußplatte

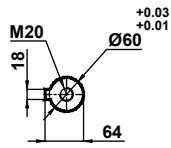

**Klemens Pozisyonları**  
Terminal Box Positions  
Klemmenkasten Positionen

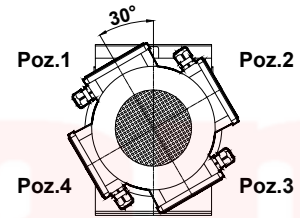

100-112-132-160-180-200  
Tip / Type / Typ

	100L	112M	132S	132M	160M	160L	180M	180L	200L
k	711.5	734.5	788.5	826.5	901.5	945.5	962	1000	1039
k1	846.5	869.5	933.5	971.5	1071.5	115.5	1132	1170	1239
n	194	218	258	258	310	310	348	348	390
n1	135	146	168	168	225	225	241	241	275
x	-	-	-	-	-	-	-	-	0.5

## KR573.05

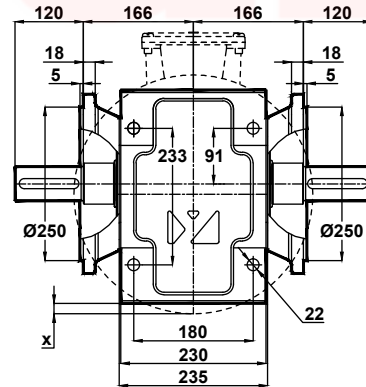
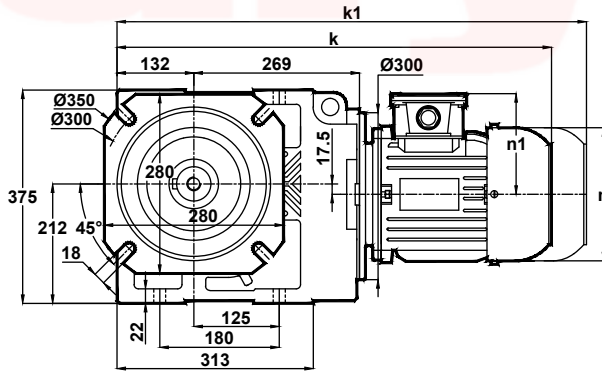

x: Motor Ayak bağlantı yüzeyinin altında ise  
x: If Motor is lower then foot mounting plane  
x: Wenn motor ist niedriger den die Anschlußplatte

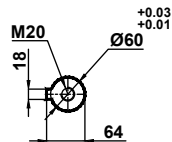

	100L	112M	132S	132M	160M	160L	180M	180L	200L
k	711.5	734.5	788.5	826.5	901.5	945.5	962	1000	1039
k1	846.5	869.5	933.5	971.5	1071.5	115.5	1132	1170	1239
n	194	218	258	258	310	310	348	348	390
n1	135	146	168	168	225	225	241	241	275
x	-	-	-	-	-	-	-	-	0.5



# Ölçü Sayfaları Dimension Pages Abmessungsseiten



-Mil ucu çektirme deliği DIN 332 sayfa 2 / Tapped center hole to DIN 332, sheet 2 / Zentrierung mit gewinde DIN 332, Blatt 2

KR573.08

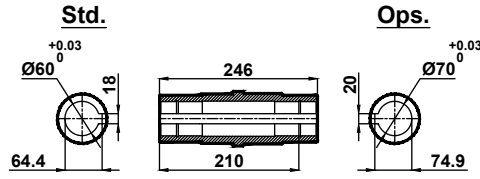
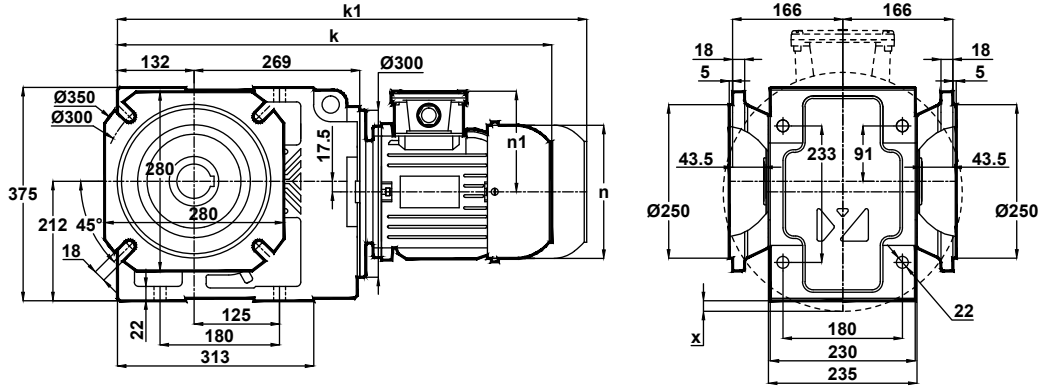

x: Motor Ayak bağlantı yüzeyinin altında ise  
x: If Motor is lower then foot mounting plane  
x: Wenn motor ist niedriger den die Anschlußplatte

	100L	112M	132S	132M	160M	160L	180M	180L	200L
k	711.5	734.5	788.5	826.5	901.5	945.5	962	1000	1039
k1	846.5	869.5	933.5	971.5	1071.5	115.5	1132	1170	1239
n	194	218	258	258	310	310	348	348	390
n1	135	146	168	168	225	225	241	241	275
x	-	-	-	-	-	-	-	-	0.5

Klemens Pozisyonları  
Terminal Box Positions  
Klemmenkasten Positionen

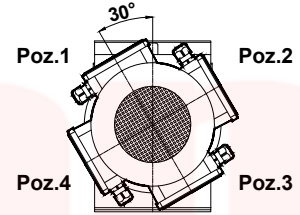

100-112-132-160-180-200  
Tip / Type / Typ





# Ölçü Sayfaları Dimension Pages Abmessungsseiten



-Mil ucu çektirme deliği DIN 332 sayfa 2 / Tapped center hole to DIN 332, sheet 2 / Zentrierung mit gewinde DIN 332, Blatt 2

## KR574.02

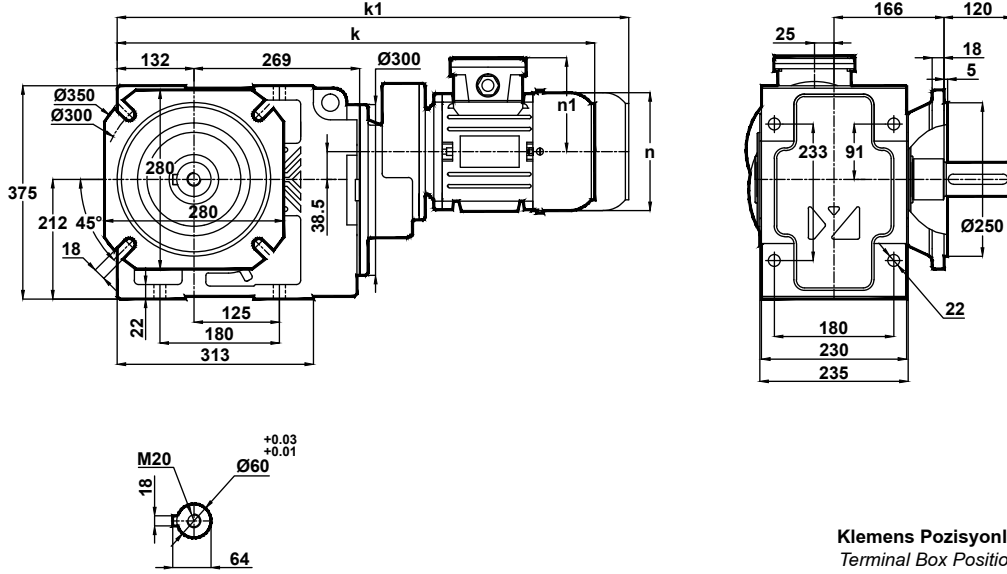

Klemens Pozisyonları  
Terminal Box Positions  
Klemmenkasten Positionen

	71	80	90S	90L	100L	112M	132S	132M
k	690	718	747	772	812	835	889	927
k1	810	838	872	897	947	970	1034	1072
n	138	156	176	176	194	218	258	258
n1	110	118	126	126	135	146	168	168

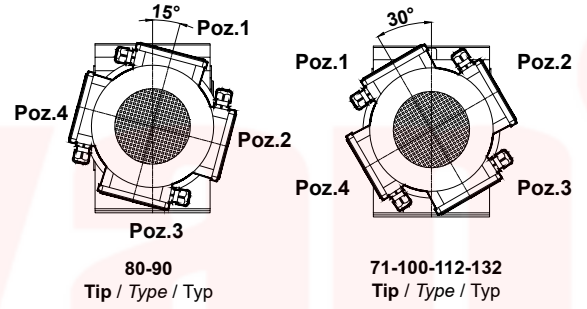

## KR574.03

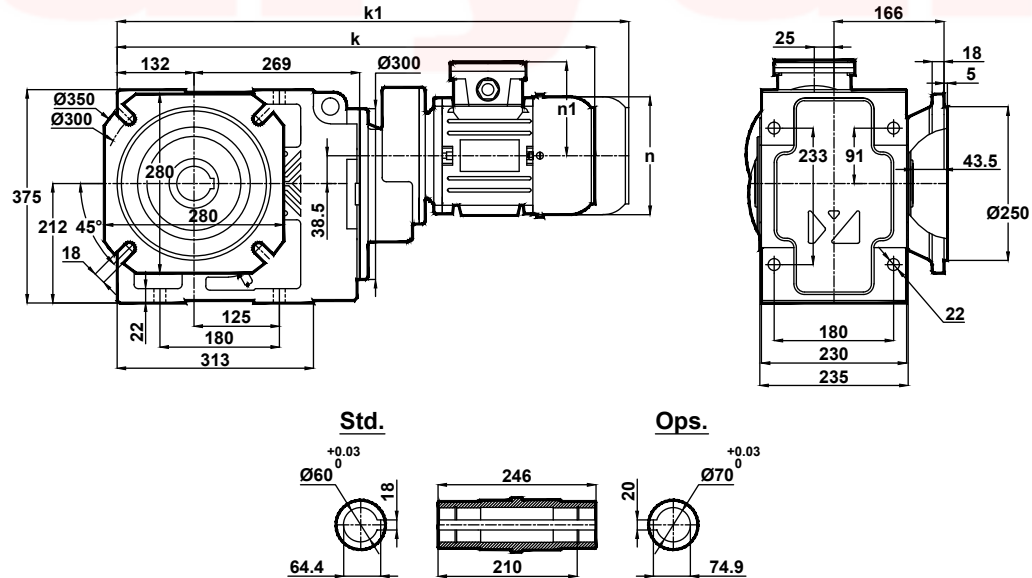

	71	80	90S	90L	100L	112M	132S	132M
k	690	718	747	772	812	835	889	927
k1	810	838	872	897	947	970	1034	1072
n	138	156	176	176	194	218	258	258
n1	110	118	126	126	135	146	168	168



# Ölçü Sayfaları Dimension Pages Abmessungsseiten



-Mil ucu çekirme deliği DIN 332 sayfa 2 / Tapped center hole to DIN 332, sheet 2 / Zentrierung mit gewinde DIN 332, Blatt 2

## KR574.04

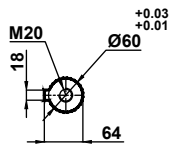
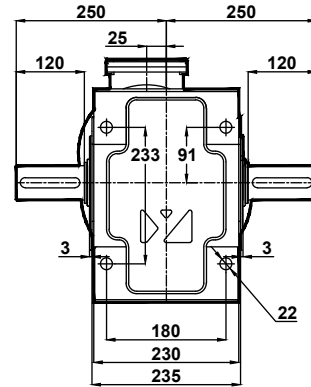
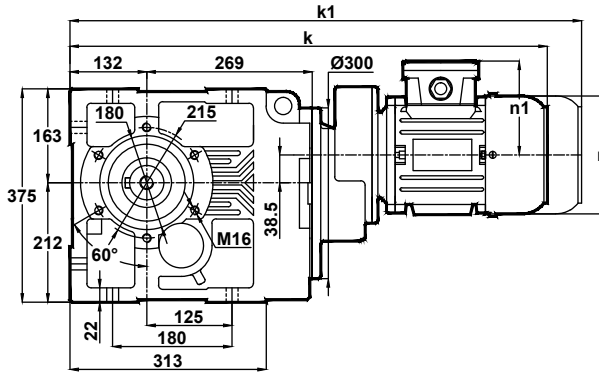

	71	80	90S	90L	100L	112M	132S	132M
k	690	718	747	772	812	835	889	927
k1	810	838	872	897	947	970	1034	1072
n	138	156	176	176	194	218	258	258
n1	110	118	126	126	135	146	168	168

### Klemens Pozisyonları Terminal Box Positions Klemmenkasten Positionen

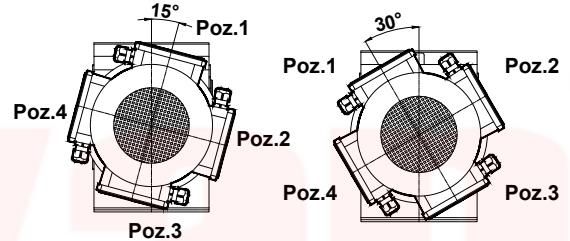

80-90  
Tip / Type / Typ

71-100-112-132  
Tip / Type / Typ

## KR574.05

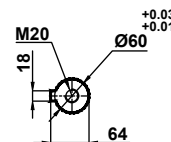
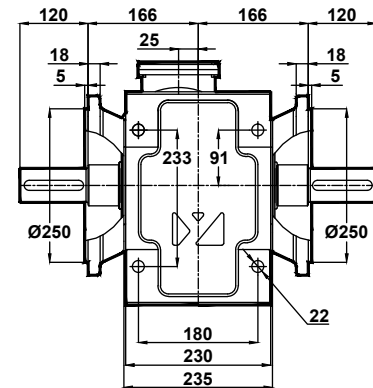
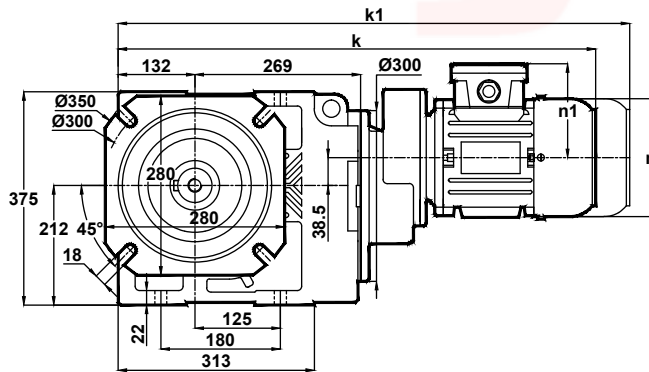

	71	80	90S	90L	100L	112M	132S	132M
k	690	718	747	772	812	835	889	927
k1	810	838	872	897	947	970	1034	1072
n	138	156	176	176	194	218	258	258
n1	110	118	126	126	135	146	168	168



# Ölçü Sayfaları Dimension Pages Abmessungsseiten



-Mil ucu çektirme deliği DIN 332 sayfa 2 / Tapped center hole to DIN 332, sheet 2 / Zentrierung mit gewinde DIN 332, Blatt 2

KR574.08

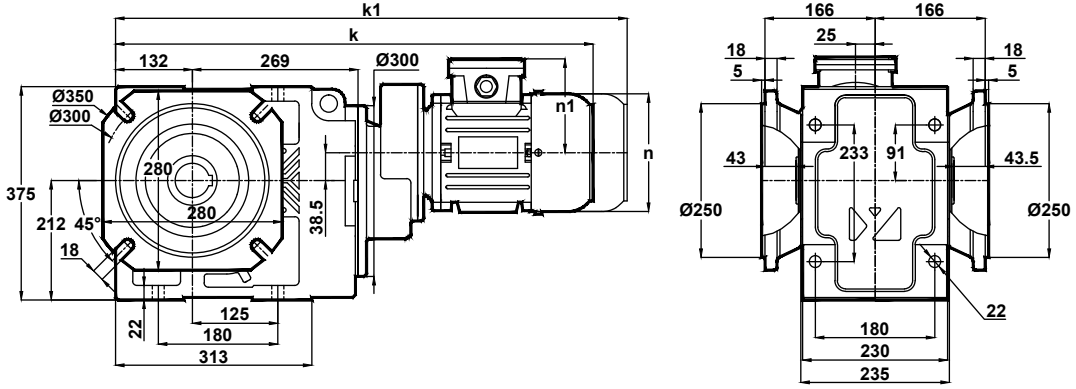

Std.

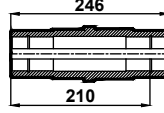
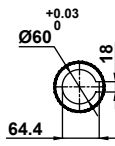

Ops.

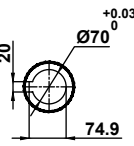

Klemens Pozisyonları  
Terminal Box Positions  
Klemmenkasten Positionen

	71	80	90S	90L	100L	112M	132S	132M
k	690	718	747	772	812	835	889	927
k1	810	838	872	897	947	970	1034	1072
n	138	156	176	176	194	218	258	258
n1	110	118	126	126	135	146	168	168

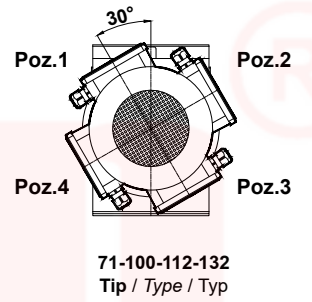
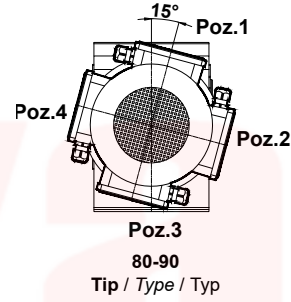



# Ölçü Sayfaları Dimension Pages Abmessungenseiten



-Mil ucu çekirme deliği DIN 332 sayfa 2 / Tapped center hole to DIN 332, sheet 2 / Zentrierung mit gewinde DIN 332, Blatt 2

KR575.00  
KR576.00

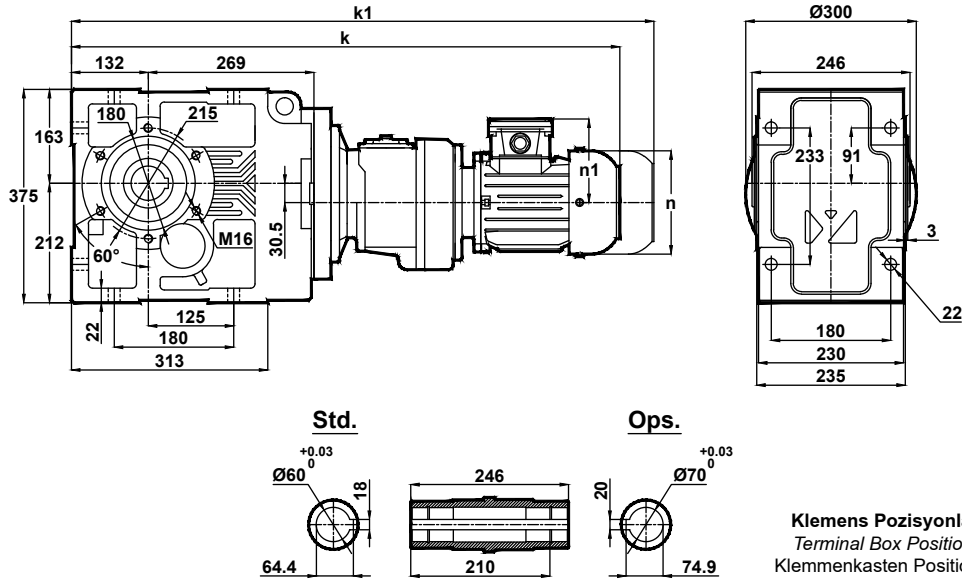

Klemens Pozisyonları  
Terminal Box Positions  
Klemmenkasten Positionen

	63	71	80	90S	90L	100L	112M
k	803	822	850	878	903	944	967
k1	-	942	970	1006	1028	1079	1102
n	116	138	156	176	176	194	218
n1	97	110	118	126	126	135	146

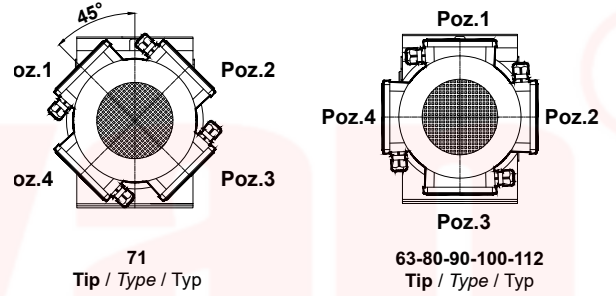

KR575.01  
KR576.01

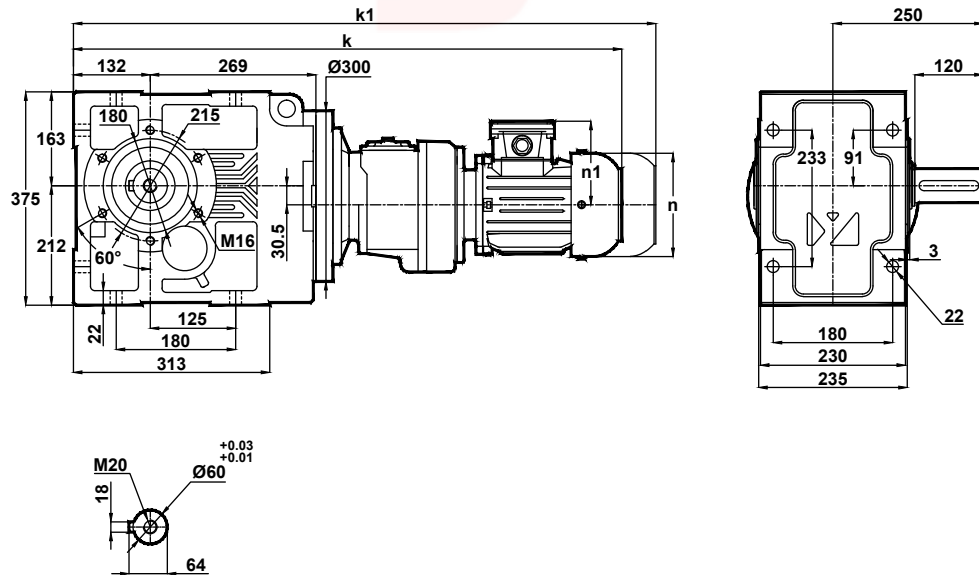

	63	71	80	90S	90L	100L	112M
k	803	822	850	878	903	944	967
k1	-	942	970	1006	1028	1079	1102
n	116	138	156	176	176	194	218
n1	97	110	118	126	126	135	146





# Ölçü Sayfaları Dimension Pages Abmessungsseiten



-Mil ucu çektirme deliği DIN 332 sayfa 2 / Tapped center hole to DIN 332, sheet 2 / Zentrierung mit gewinde DIN 332, Blatt 2

KR575.02  
KR576.02

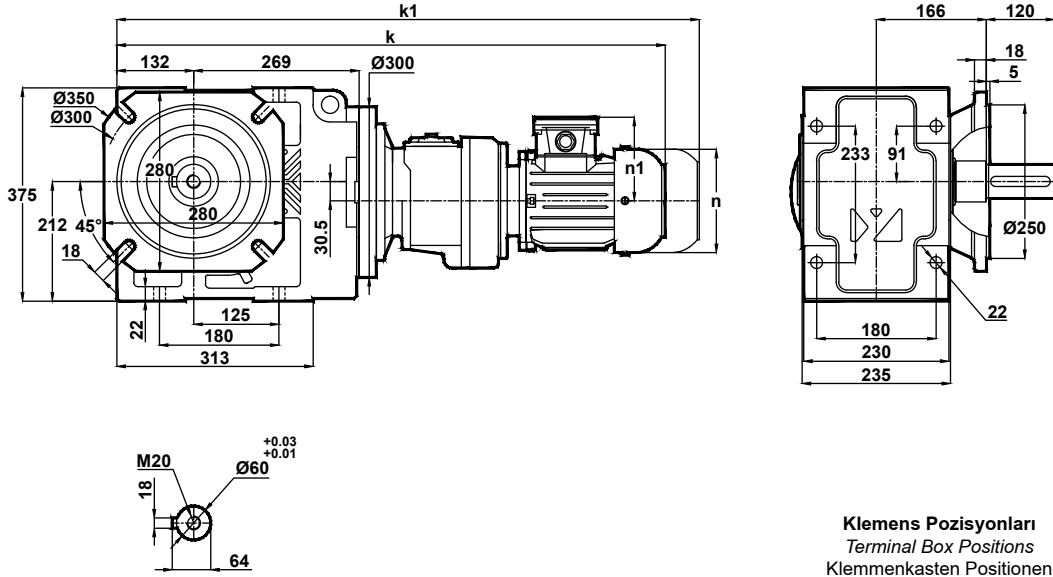

Klemens Pozisyonları  
Terminal Box Positions  
Klemmenkasten Positionen

	63	71	80	90S	90L	100L	112M
k	803	822	850	878	903	944	967
k1	-	942	970	1006	1028	1079	1102
n	116	138	156	176	176	194	218
n1	97	110	118	126	126	135	146

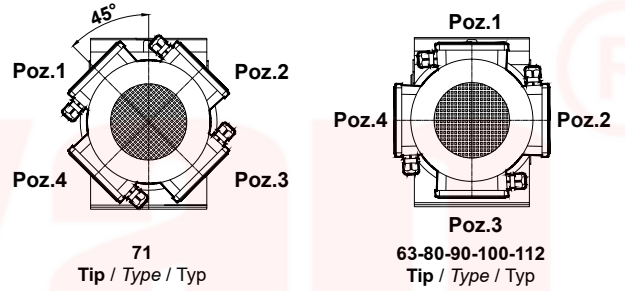

KR575.03  
KR576.03

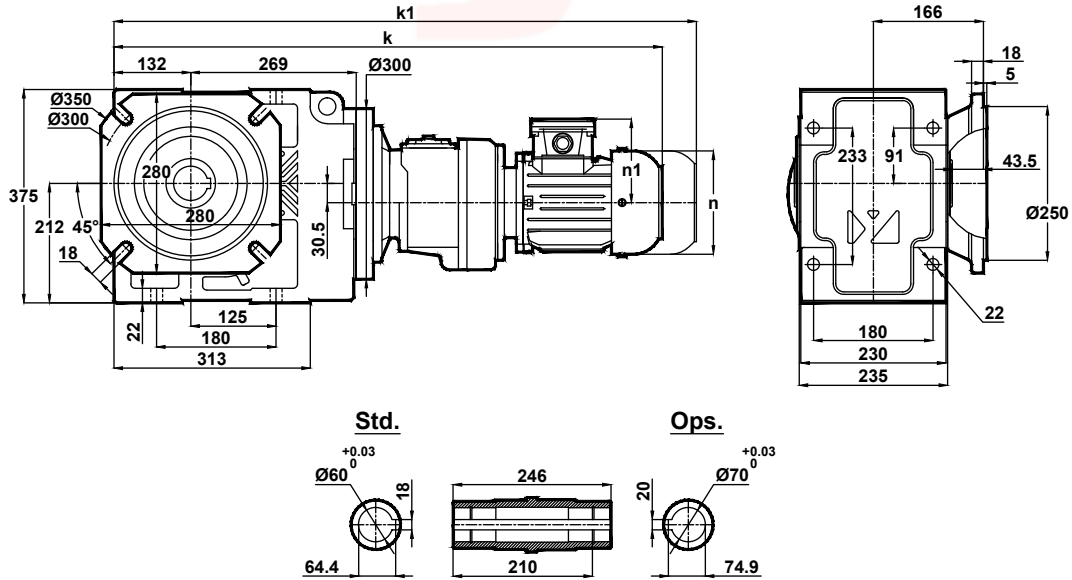

	63	71	80	90S	90L	100L	112M
k	803	822	850	878	903	944	967
k1	-	942	970	1006	1028	1079	1102
n	116	138	156	176	176	194	218
n1	97	110	118	126	126	135	146



# Ölçü Sayfaları Dimension Pages Abmessungenseiten



-Mil ucu çektirme deliği DIN 332 sayfa 2 / Tapped center hole to DIN 332, sheet 2 / Zentrierung mit gewinde DIN 332, Blatt 2

KR575.04  
KR576.04

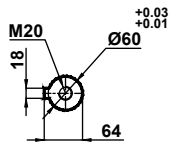
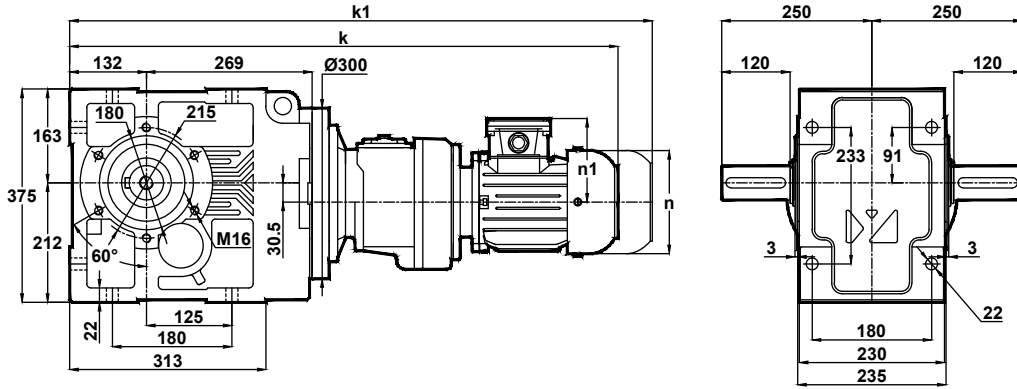

Klemens Pozisyonları  
Terminal Box Positions  
Klemmenkasten Positionen

	63	71	80	90S	90L	100L	112M
k	803	822	850	878	903	944	967
k1	-	942	970	1003	1028	1079	1102
n	116	138	156	176	176	194	218
n1	97	110	118	126	126	135	146

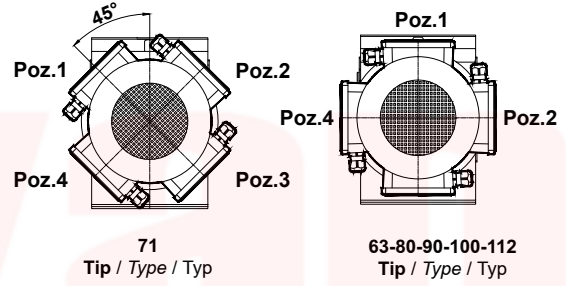

KR575.05  
KR576.05

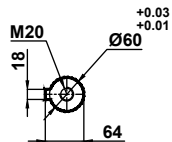
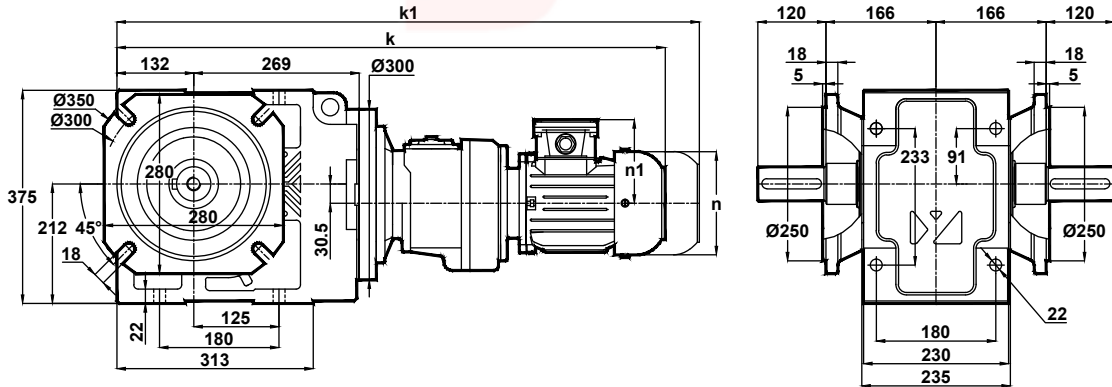

	63	71	80	90S	90L	100L	112M
k	803	821.5	850	877.5	902.5	943.5	966.5
k1	-	941.5	970	1002.5	1027.5	1078.5	1101.5
n	116	138	156	176	176	194	194
n1	97	110	118	126	126	135	135



# Ölçü Sayfaları Dimension Pages Abmessungsseiten



-Mil ucu çektirme deliği DIN 332 sayfa 2 / Tapped center hole to DIN 332, sheet 2 / Zentrierung mit gewinde DIN 332, Blatt 2

KR575.08  
KR576.08

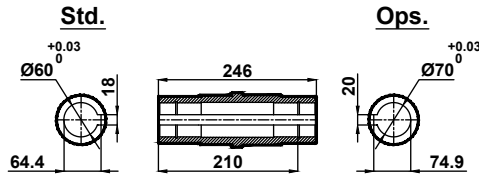
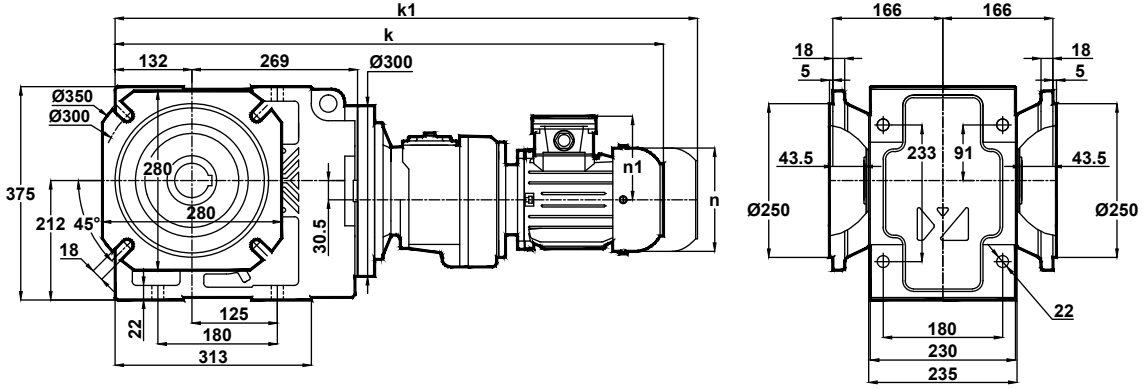

Klemens Pozisyonları  
Terminal Box Positions  
Klemmenkasten Positionen

	63	71	80	90S	90L	100L	112M
k	803	821.5	850	877.5	902.5	943.5	966.5
k1	-	941.5	970	1002.5	1027.5	1078.5	1101.5
n	116	138	156	176	176	194	194
n1	97	110	118	126	126	135	135

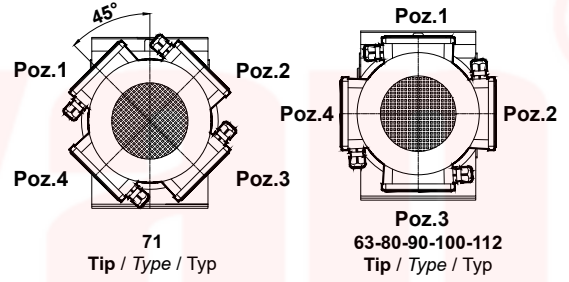





# Ölçü Sayfaları Dimension Pages Abmessungsseiten



-Mil ucu çektirme deliği DIN 332 sayfa 2 / Tapped center hole to DIN 332, sheet 2 / Zentrierung mit gewinde DIN 332, Blatt 2

## KR673.02

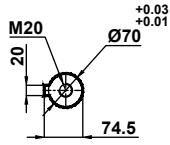
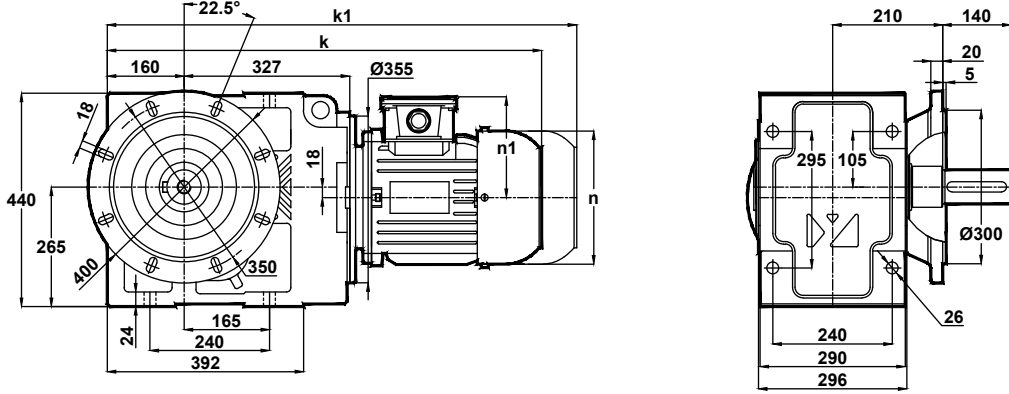

Klemens Pozisyonları  
Terminal Box Positions  
Klemmenkasten Positionen

	100L	112M	132S	132M	160M	160L	180M	180L	200L	225S	225M
k	704	813	867	905	979	1023	1037	1075	1117	1143	1168
k1	839	948	1012	1050	1149	1193	1207	1245	1317	-	-
n	194	218	258	258	310	310	348	348	390	433	433
n1	135	146	168	168	225	225	241	241	275	285	285

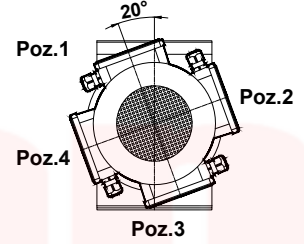

100-112-132-160-180-200-225  
Tip / Type / Typ

## KR673.03

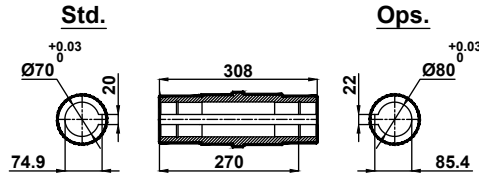
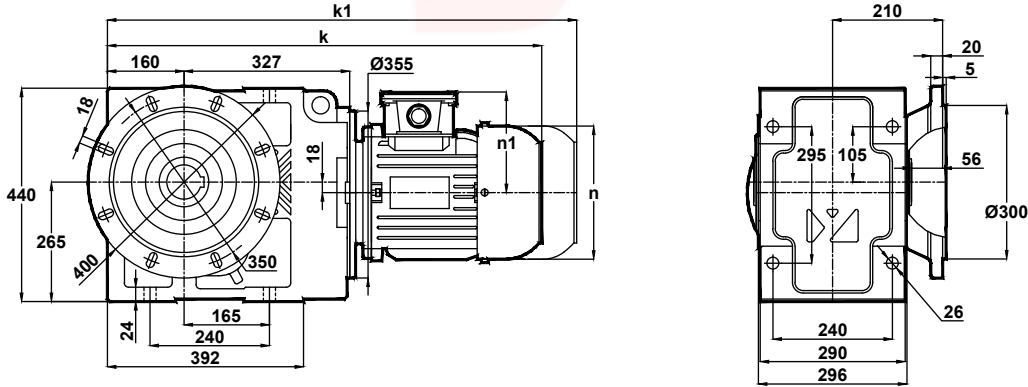

	100L	112M	132S	132M	160M	160L	180M	180L	200L	225S	225M
k	704	813	867	905	979	1023	1037	1075	1117	1143	1168
k1	839	948	1012	1050	1149	1193	1207	1245	1317	-	-
n	194	218	258	258	310	310	348	348	390	433	433
n1	135	146	168	168	225	225	241	241	275	285	285



# Ölçü Sayfaları Dimension Pages Abmessungsseiten



-Mil ucu çekirme deliği DIN 332 sayfa 2 / Tapped center hole to DIN 332, sheet 2 / Zentrierung mit gewinde DIN 332, Blatt 2

## KR673.04

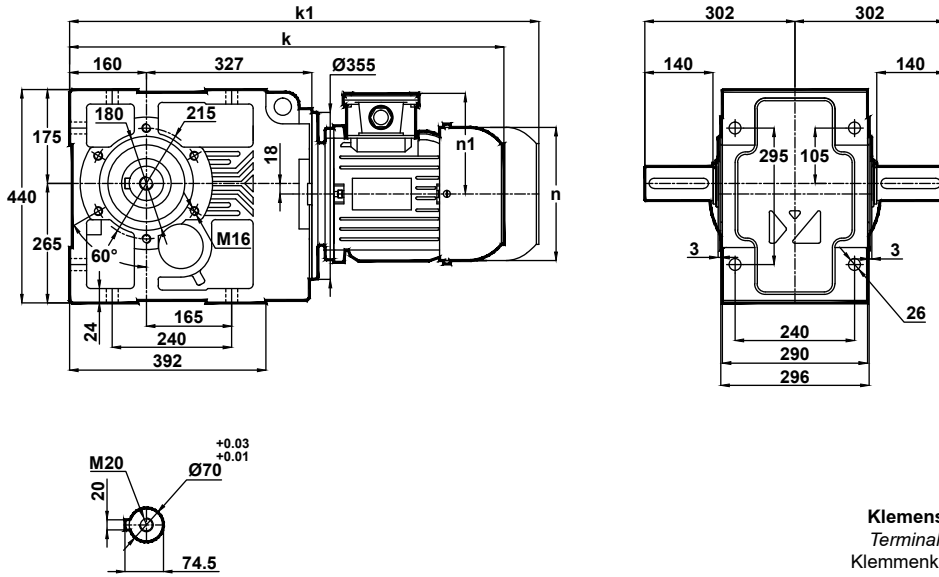

Klemens Pozisyonları  
Terminal Box Positions  
Klemmenkasten Positionen

	100L	112M	132S	132M	160M	160L	180M	180L	200L	225S	225M
k	704	813	867	905	979	1023	1037	1075	1117	1143	1168
k1	839	948	1012	1050	1149	1193	1207	1245	1317	-	-
n	194	218	258	258	310	310	348	348	390	433	433
n1	135	146	168	168	225	225	241	241	275	285	285

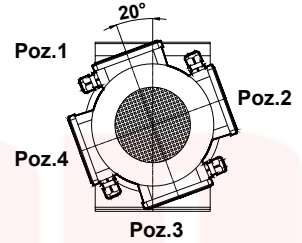

100-112-132-160-180-200-225  
Tip / Type / Typ

## KR673.05

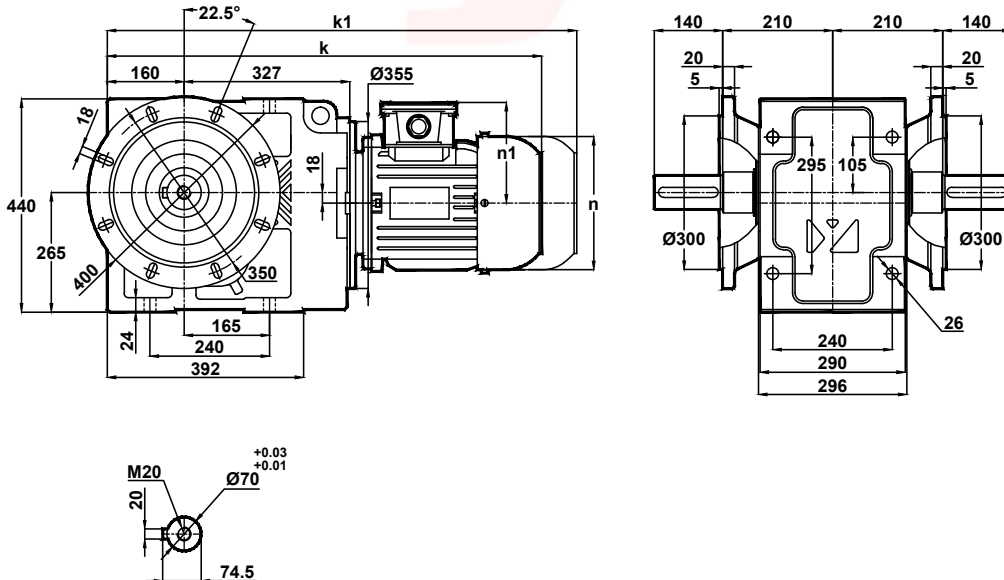

	100L	112M	132S	132M	160M	160L	180M	180L	200L	225S	225M
k	704	813	867	905	979	1023	1037	1075	1117	1143	1168
k1	839	948	1012	1050	1149	1193	1207	1245	1317	-	-
n	194	218	258	258	310	310	348	348	390	433	433
n1	135	146	168	168	225	225	241	241	275	285	285



# Ölçü Sayfaları Dimension Pages Abmessungsseiten



-Mil ucu çektirme deliği DIN 332 sayfa 2 / Tapped center hole to DIN 332, sheet 2 / Zentrierung mit gewinde DIN 332, Blatt 2

KR673.08

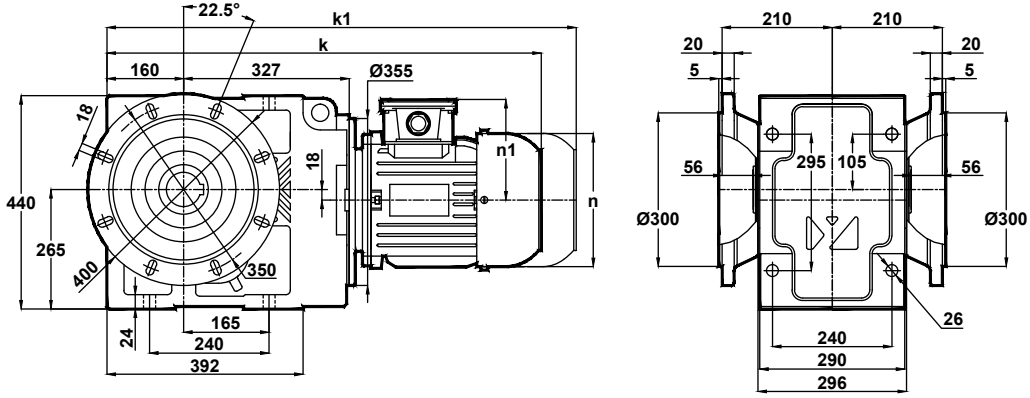

Std.

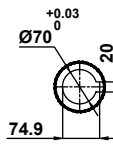

Ops.

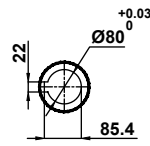

Klemens Pozisyonları  
Terminal Box Positions  
Klemmenkasten Positionen

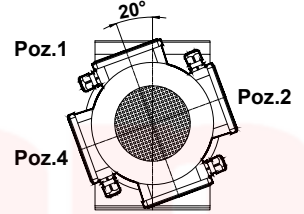

Poz.3  
100-112-132-160-180-200-225  
Tip / Type / Typ

	100L	112M	132S	132M	160M	160L	180M	180L	200L	225S	225M
k	704	813	867	905	979	1023	1037	1075	1117	1143	1168
k1	839	948	1012	1050	1149	1193	1207	1245	1317	-	-
n	194	218	258	258	310	310	348	348	390	433	433
n1	135	146	168	168	225	225	241	241	275	285	285



# Ölçü Sayfaları Dimension Pages Abmessungenseiten



-Mil ucu çekirme deliği DIN 332 sayfa 2 / Tapped center hole to DIN 332, sheet 2 / Zentrierung mit gewinde DIN 332, Blatt 2

## KR674.00

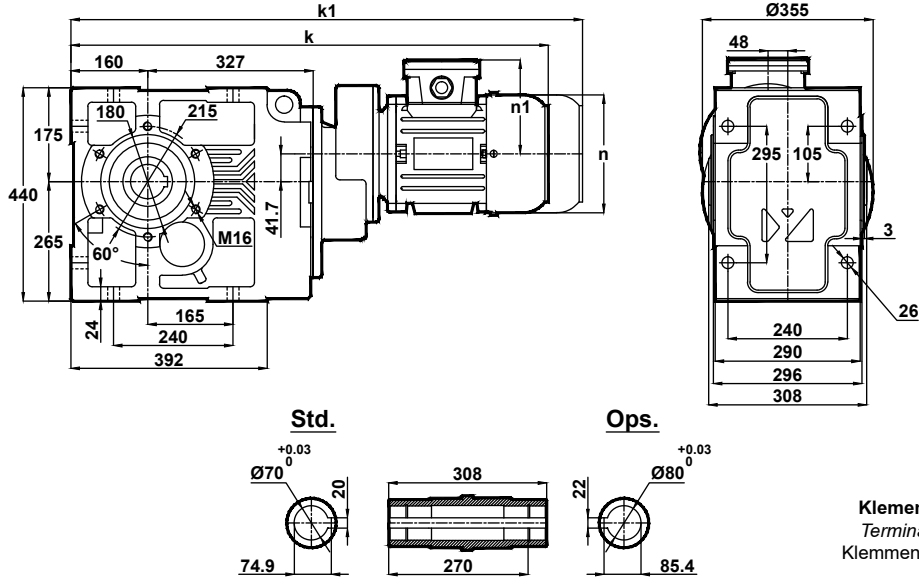

Std.

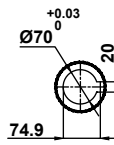

Ops.

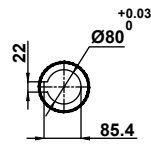

Klemens Pozisyonları  
Terminal Box Positions  
Klemmenkasten Positionen

	80	90S	90L	100L	112M	132S	132M	160M	160L	180M	180L
k	815	843	868	906	932	981	1019	1094	1138	1155	1193
k1	935	968	993	1041	1067	1126	1164	1264	1308	1325	1363
n	156	176	176	194	218	258	258	310	310	348	348
n1	118	126	126	135	146	168	168	225	225	241	241

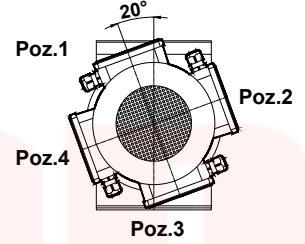

80-90-100-112-132-160-180  
Tip / Type / Typ

## KR674.01

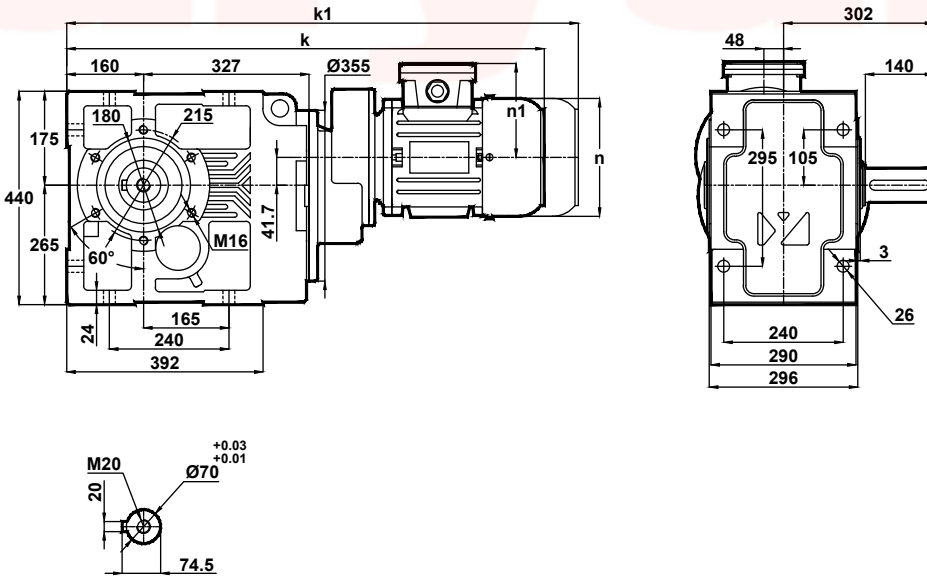

	80	90S	90L	100L	112M	132S	132M	160M	160L	180M	180L
k	815	843	868	906	932	981	1019	1094	1138	1155	1193
k1	935	968	993	1041	1067	1126	1164	1264	1308	1325	1363
n	156	176	176	194	218	258	258	310	310	348	348
n1	118	126	126	135	146	168	168	225	225	241	241





# Ölçü Sayfaları Dimension Pages Abmessungsseiten



-Mil ucu çektirme deliği DIN 332 sayfa 2 / Tapped center hole to DIN 332, sheet 2 / Zentrierung mit gewinde DIN 332, Blatt 2

## KR674.02

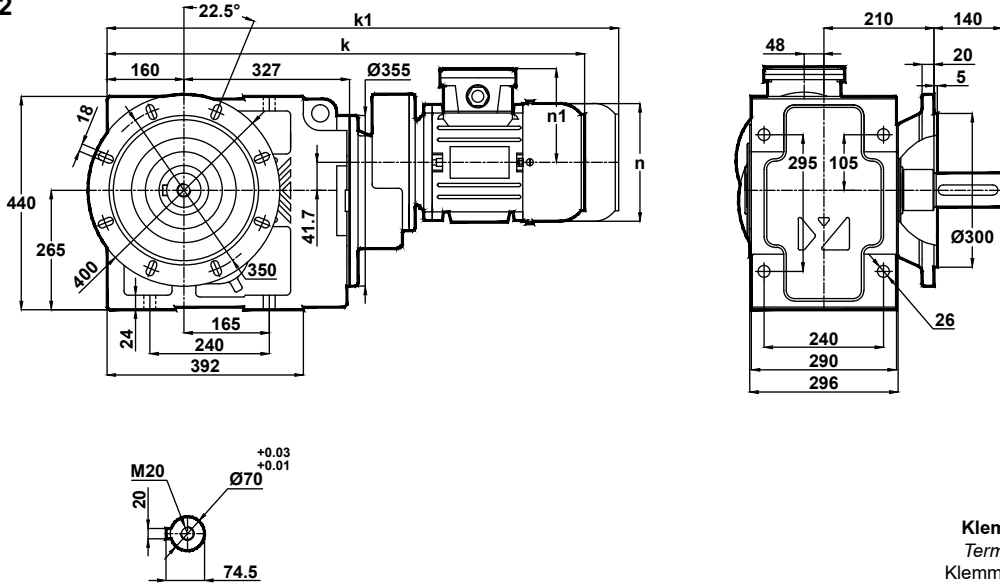

Klemens Pozisyonları  
Terminal Box Positions  
Klemmenkasten Positionen

	80	90S	90L	100L	112M	132S	132M	160M	160L	180M	180L
k	815	843	868	906	932	981	1019	1094	1138	1155	1193
k1	935	968	993	1041	1067	1126	1164	1264	1308	1325	1363
n	156	176	176	194	218	258	258	310	310	348	348
n1	118	126	126	135	146	168	168	225	225	241	241

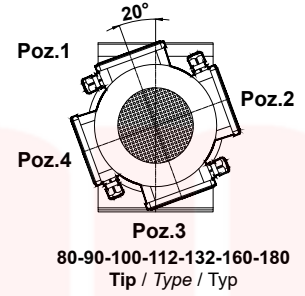

## KR674.03

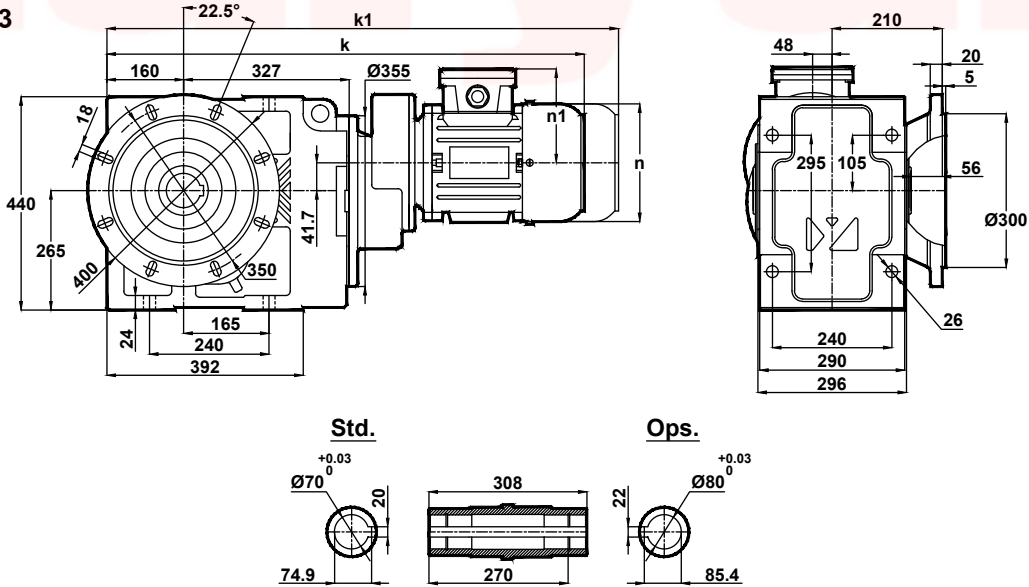

Std.

Ops.

	80	90S	90L	100L	112M	132S	132M	160M	160L	180M	180L
k	815	843	868	906	932	981	1019	1094	1138	1155	1193
k1	935	968	993	1041	1067	1126	1164	1264	1308	1325	1363
n	156	176	176	194	218	258	258	310	310	348	348
n1	118	126	126	135	146	168	168	225	225	241	241



# Ölçü Sayfaları Dimension Pages Abmessungenseiten



-Mil ucu çekirme deliği DIN 332 sayfa 2 / Tapped center hole to DIN 332, sheet 2 / Zentrierung mit gewinde DIN 332, Blatt 2

## KR674.04

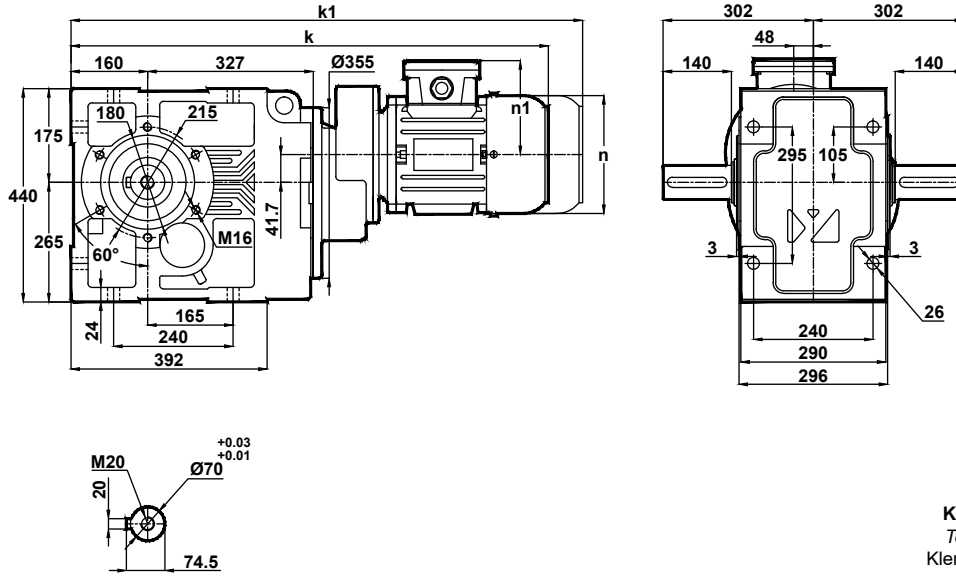

Klemens Pozisyonları  
Terminal Box Positions  
Klemmenkasten Positionen

	80	90S	90L	100L	112M	132S	132M	160M	160L	180M	180L
k	815	843	868	906	932	981	1019	1094	1138	1155	1193
k1	935	968	993	1041	1067	1126	1164	1264	1308	1325	1363
n	156	176	176	194	218	258	258	310	310	348	348
n1	118	126	126	135	146	168	168	225	225	241	241

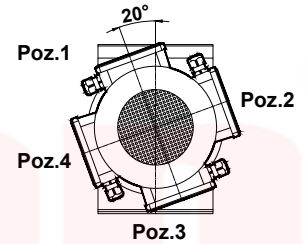

80-90-100-112-132-160-180  
Tip / Type / Typ

## KR674.05

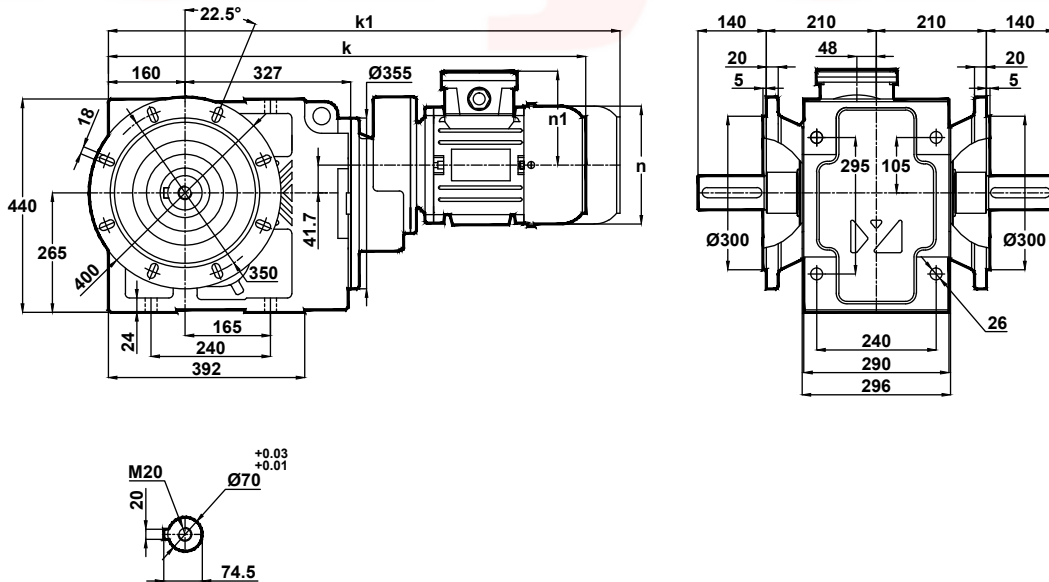

	80	90S	90L	100L	112M	132S	132M	160M	160L	180M	180L
k	815	843	868	906	932	981	1019	1094	1138	1155	1193
k1	935	968	993	1041	1067	1126	1164	1264	1308	1325	1363
n	156	176	176	194	218	258	258	310	310	348	348
n1	118	126	126	135	146	168	168	225	225	241	241



# Ölçü Sayfaları Dimension Pages Abmessungsseiten



-Mil ucu çektirme deliği DIN 332 sayfa 2 / Tapped center hole to DIN 332, sheet 2 / Zentrierung mit gewinde DIN 332, Blatt 2

KR674.08

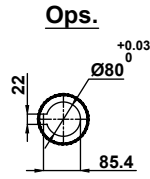
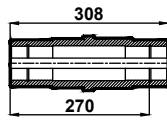
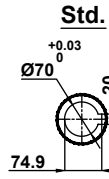
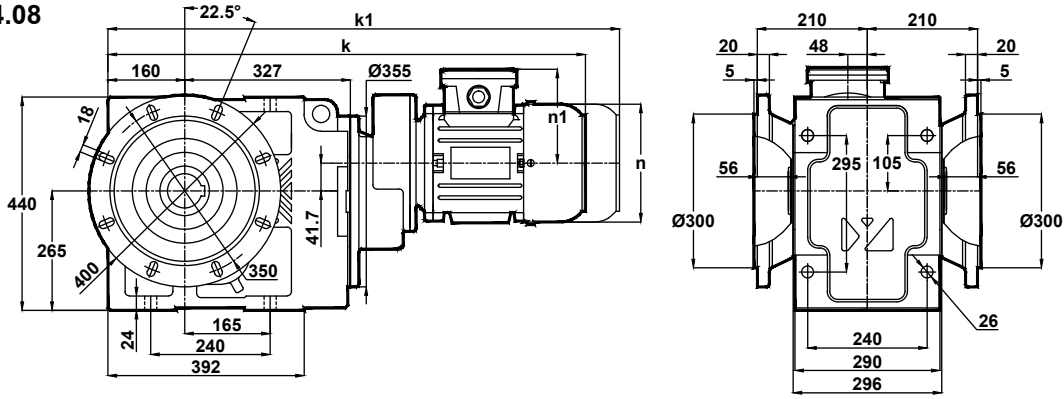

**Klemens Pozisyonları**  
Terminal Box Positions  
Klemmenkasten Positionen

	80	90S	90L	100L	112M	132S	132M	160M	160L	180M	180L
<b>k</b>	815	843	868	906	932	981	1019	1094	1138	1155	1193
<b>k1</b>	935	968	993	1041	1067	1126	1164	1264	1308	1325	1363
<b>n</b>	156	176	176	194	218	258	258	310	310	348	348
<b>n1</b>	118	126	126	135	146	168	168	225	225	241	241

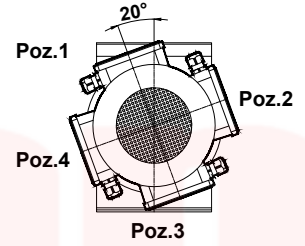

**80-90-100-112-132-160-180**  
Tip / Type / Typ



# Ölçü Sayfaları Dimension Pages Abmessungenseiten



-Mil ucu çektirme deliği DIN 332 sayfa 2 / Tapped center hole to DIN 332, sheet 2 / Zentrierung mit gewinde DIN 332, Blatt 2

KR675.00  
KR676.00

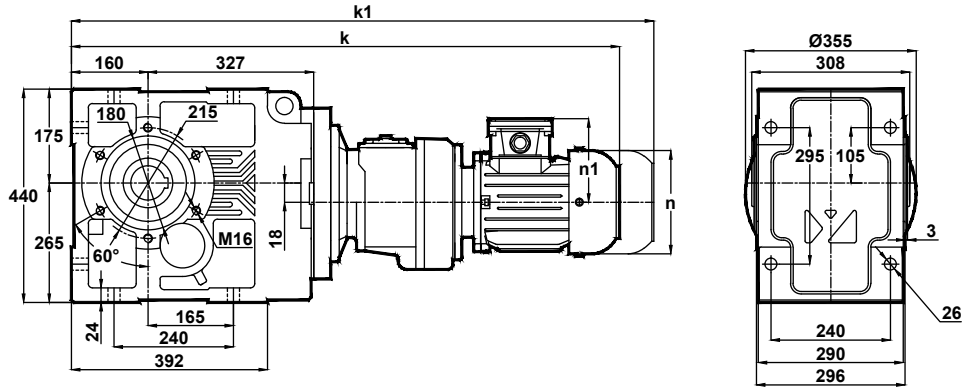

Std.

Ops.

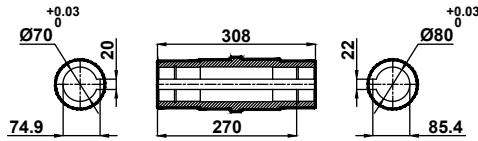

Klemens Pozisyonları  
Terminal Box Positions  
Klemmenkasten Positionen

	71	80	90S	90L	100L	112M	132S	132M
k	933	961	990	1015	1055	1078	1132	1170
k1	1053	1081	1115	1140	1190	1213	1277	1315
n	138	156	176	176	194	218	258	258
n1	110	118	126	126	135	146	168	168

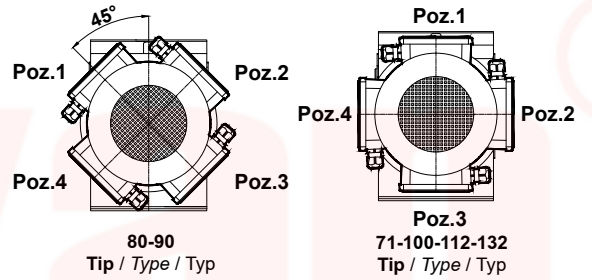

KR675.01  
KR676.01

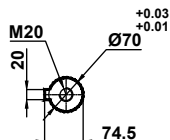
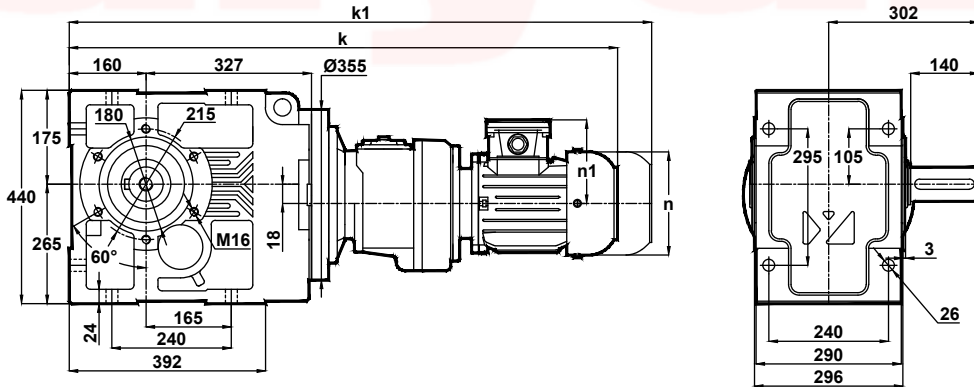

	71	80	90S	90L	100L	112M	132S	132M
k	933	961	990	1015	1055	1078	1132	1170
k1	1053	1081	1115	1140	1190	1213	1277	1315
n	138	156	176	176	194	218	258	258
n1	110	118	126	126	135	146	168	168



# Ölçü Sayfaları Dimension Pages Abmessungsseiten



-Mil ucu çekirme deliği DIN 332 sayfa 2 / Tapped center hole to DIN 332, sheet 2 / Zentrierung mit gewinde DIN 332, Blatt 2

KR675.02  
KR676.02

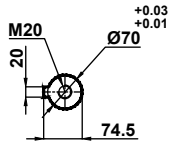
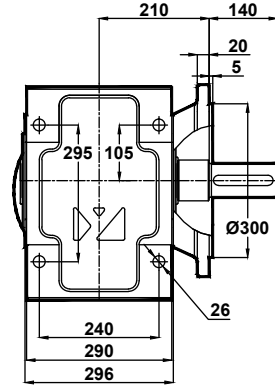
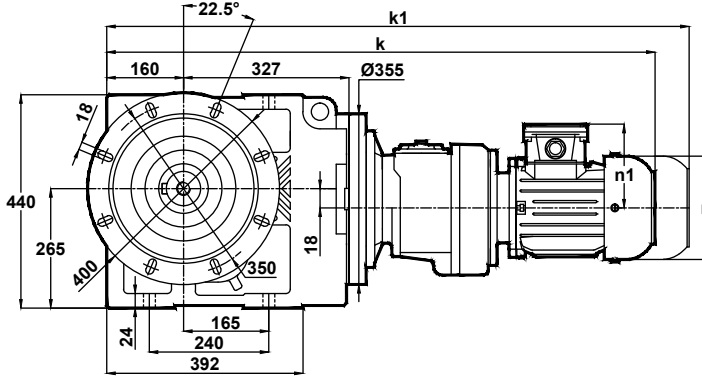

Klemens Pozisyonları  
Terminal Box Positions  
Klemmenkasten Positionen

	71	80	90S	90L	100L	112M	132S	132M
k	933	961	990	1015	1055	1078	1132	1170
k1	1053	1081	1115	1140	1190	1213	1277	1315
n	138	156	176	176	194	218	258	258
n1	110	118	126	126	135	146	168	168

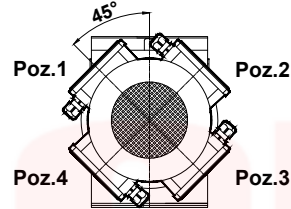

80-90  
Tip / Type / Typ

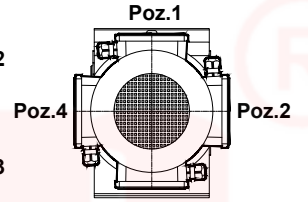

Poz.3  
71-100-112-132  
Tip / Type / Typ

KR675.03  
KR676.03

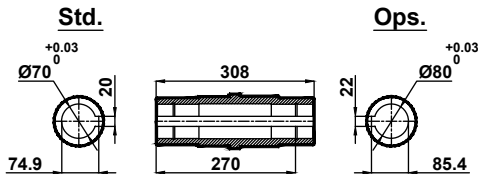
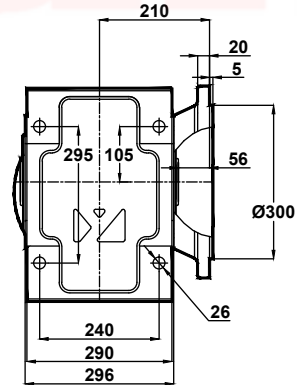
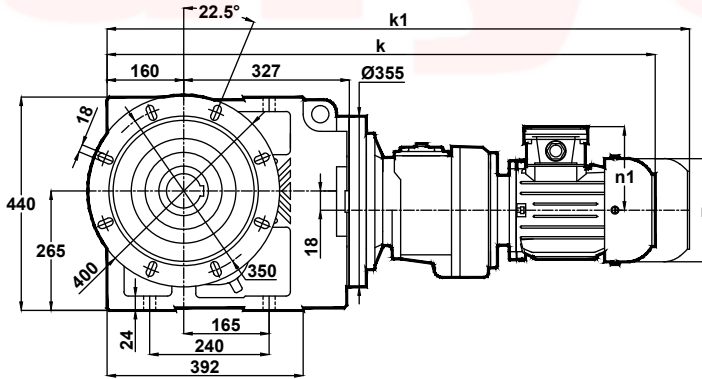

	71	80	90S	90L	100L	112M	132S	132M
k	933	961	990	1015	1055	1078	1132	1170
k1	1053	1081	1115	1140	1190	1213	1277	1315
n	138	156	176	176	194	218	258	258
n1	110	118	126	126	135	146	168	168



# Ölçü Sayfaları Dimension Pages Abmessungenseiten



-Mil ucu çektirme deliği DIN 332 sayfa 2 / Tapped center hole to DIN 332, sheet 2 / Zentrierung mit gewinde DIN 332, Blatt 2

KR675.04  
KR676.04

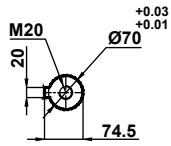
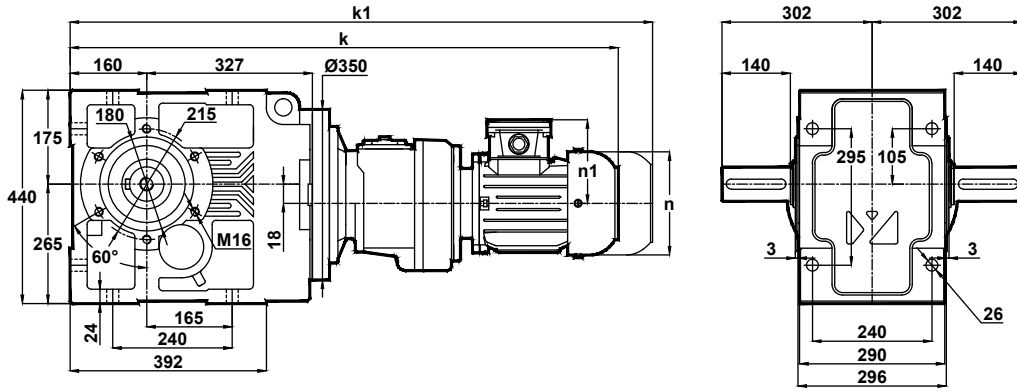

Klemens Pozisyonları  
Terminal Box Positions  
Klemmenkasten Positionen

	71	80	90S	90L	100L	112M	132S	132M
k	933	961	990	1015	1055	1078	1132	1170
k1	1053	1081	1115	1140	1190	1213	1277	1315
n	138	156	176	176	194	218	258	258
n1	110	118	126	126	135	146	168	168

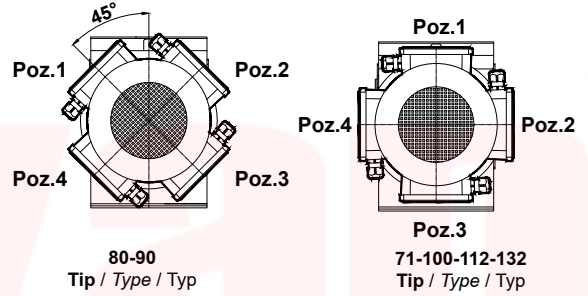

KR675.05  
KR676.05

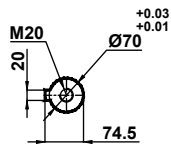
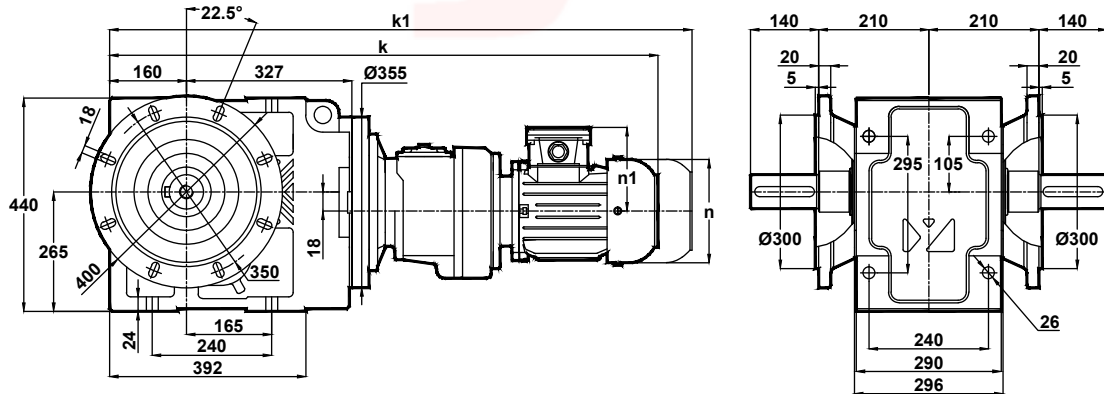

	71	80	90S	90L	100L	112M	132S	132M
k	933	961	990	1015	1055	1078	1132	1170
k1	1053	1081	1115	1140	1190	1213	1277	1315
n	138	156	176	176	194	218	258	258
n1	110	118	126	126	135	146	168	168



# Ölçü Sayfaları Dimension Pages Abmessungsseiten



-Mil ucu çektirme deliği DIN 332 sayfa 2 / Tapped center hole to DIN 332, sheet 2 / Zentrierung mit gewinde DIN 332, Blatt 2

KR675.08  
KR676.08

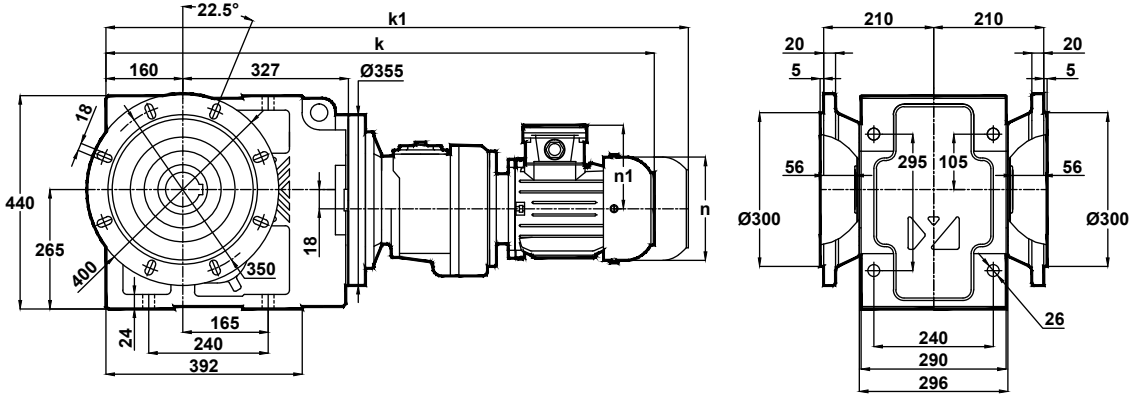

Std.

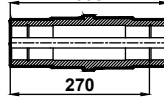
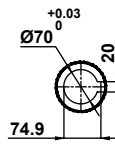

Ops.

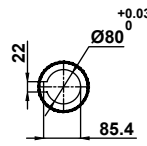

Klemens Pozisyonları  
Terminal Box Positions  
Klemmenkasten Positionen

	71	80	90S	90L	100L	112M	132S	132M
k	933	961	990	1015	1055	1078	1132	1170
k1	1053	1081	1115	1140	1190	1213	1277	1315
n	138	156	176	176	194	218	258	258
n1	110	118	126	126	135	146	168	168

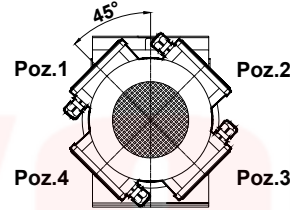

80-90  
Tip / Type / Typ

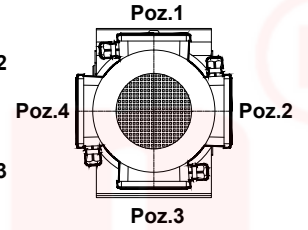

71-100-112-132  
Tip / Type / Typ



# Ölçü Sayfaları Dimension Pages Abmessungsseiten



-Mil ucu çektirme deliği DIN 332 sayfa 2 / Tapped center hole to DIN 332, sheet 2 / Zentrierung mit gewinde DIN 332, Blatt 2

## KR773.00

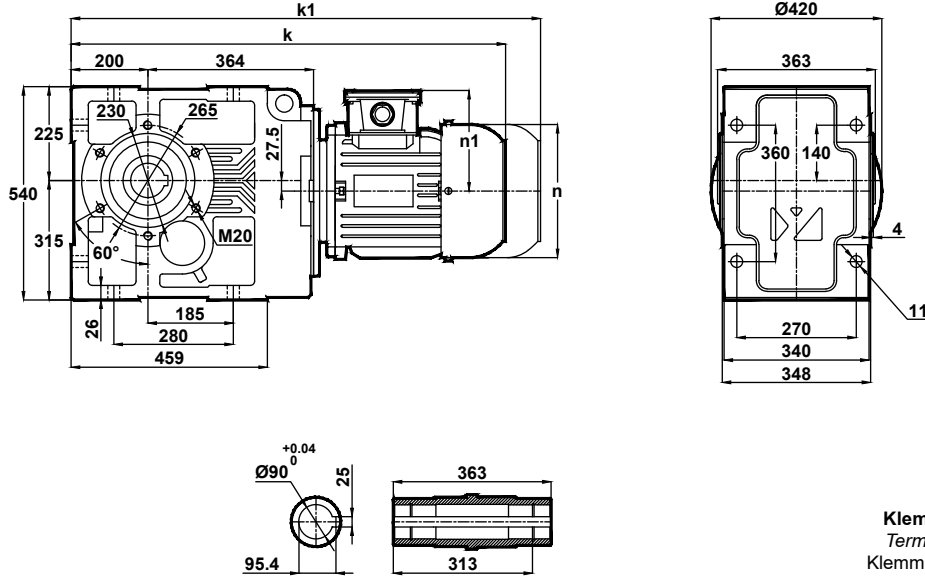

	132S	132M	160M	160L	180M	180L	200L	225S	225M	250M
k	938	976	1052	1096	1113	1151	1190	1217	1242	1346
k1	1083	1121	1222	1266	1283	1321	1390	-	-	-
n	258	258	310	310	348	348	390	433	433	480
n1	168	168	225	225	241	241	275	285	285	322

Klemens Pozisyonları  
Terminal Box Positions  
Klemmenkasten Positionen

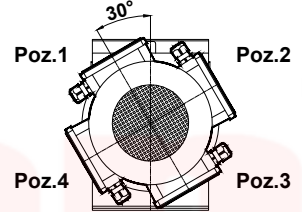

132-160-180-200-225-250  
Tip / Type / Typ

## KR773.01

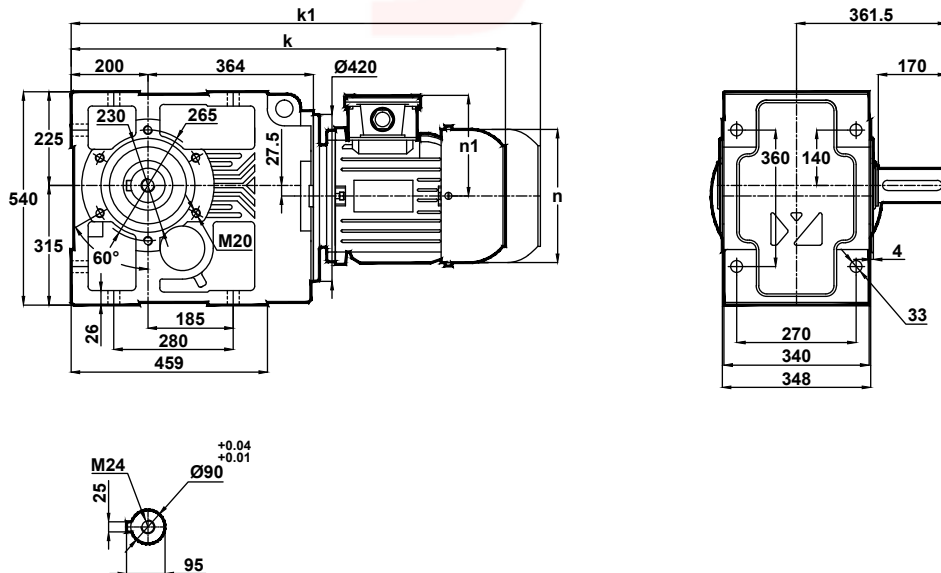

	132S	132M	160M	160L	180M	180L	200L	225S	225M	250M
k	938	976	1052	1096	1113	1151	1190	1217	1242	1346
k1	1083	11521	1222	1266	1283	1321	1390	-	-	-
n	258	258	310	310	348	348	390	433	433	480
n1	168	168	225	225	241	241	275	285	285	322





# Ölçü Sayfaları Dimension Pages Abmessungsseiten



-Mil ucu çektirme deliği DIN 332 sayfa 2 / Tapped center hole to DIN 332, sheet 2 / Zentrierung mit gewinde DIN 332, Blatt 2

## KR773.02

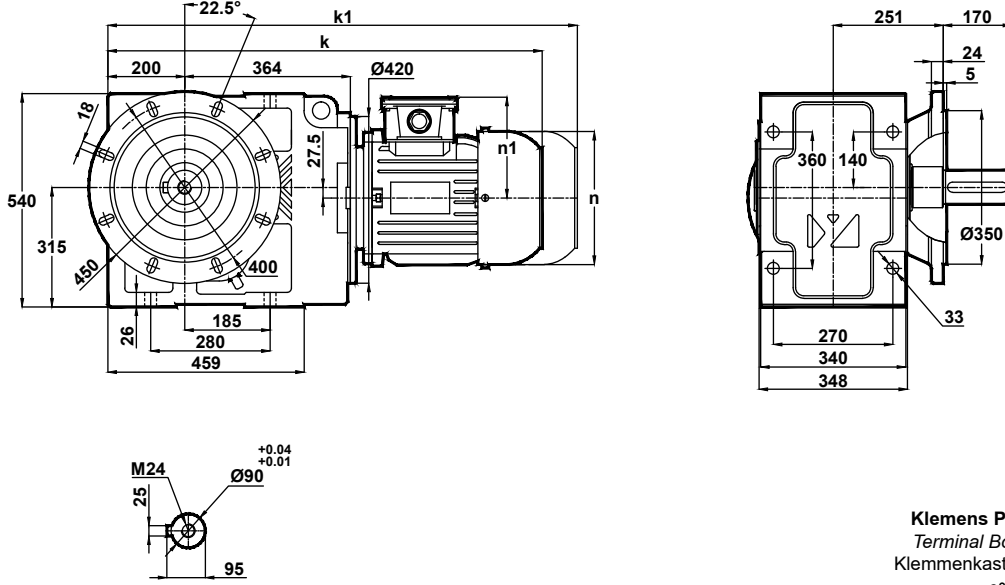

	132S	132M	160M	160L	180M	180L	200L	225S	225M	250M
k	938	976	1052	1096	1113	1151	1190	1217	1242	1346
k1	1083	1121	1222	1266	1283	1321	1390	-	-	-
n	258	258	310	310	348	348	390	433	433	480
n1	168	168	225	225	241	241	275	285	285	322

Klemens Pozisyonları  
Terminal Box Positions  
Klemmenkasten Positionen

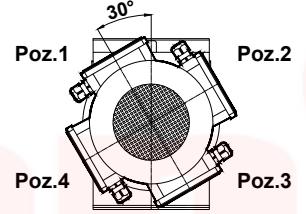

132-160-180-200-225-250  
Tip / Type / Typ

## KR773.03

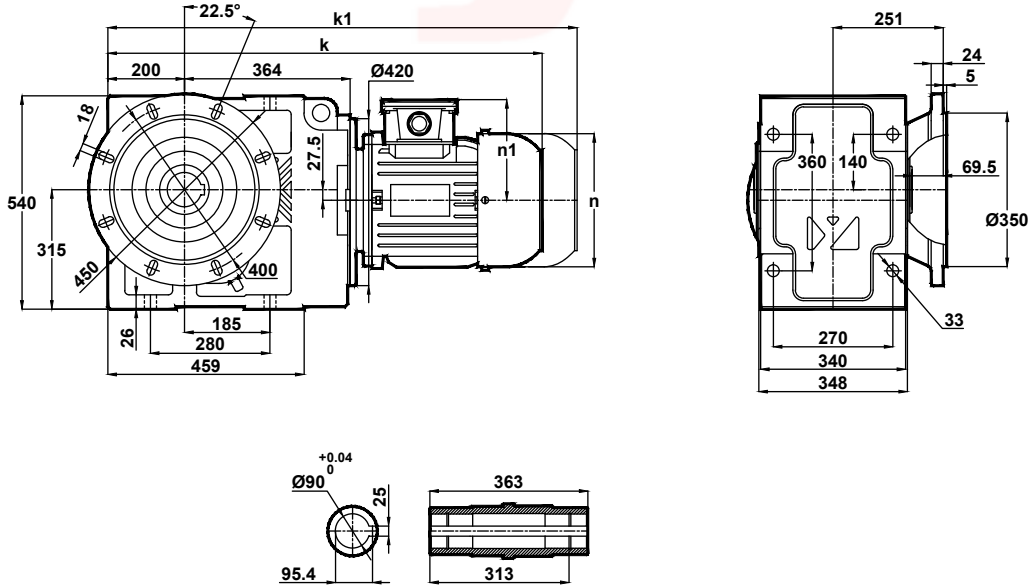

	132S	132M	160M	160L	180M	180L	200L	225S	225M	250M
k	938	976	1052	1096	1113	1151	1190	1217	1242	1346
k1	1083	1121	1222	1266	1283	1321	1390	-	-	-
n	258	258	310	310	348	348	390	433	433	480
n1	168	168	225	225	241	241	275	285	285	322



# Ölçü Sayfaları Dimension Pages Abmessungenseiten



-Mil ucu çekirme deliği DIN 332 sayfa 2 / Tapped center hole to DIN 332, sheet 2 / Zentrierung mit gewinde DIN 332, Blatt 2

## KR773.04

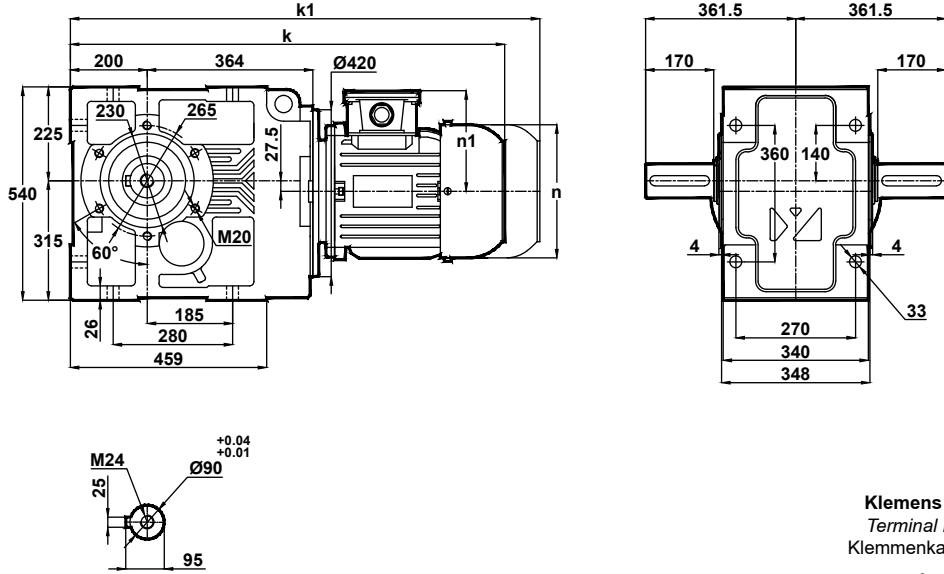

	132S	132M	160M	160L	180M	180L	200L	225S	225M	250M
k	938	976	1052	1096	1113	1151	1190	1217	1242	1346
k1	1083	1121	1222	1266	1283	1321	1390	-	-	-
n	258	258	310	310	348	348	390	433	433	480
n1	168	168	225	225	241	241	275	285	285	322

Klemens Pozisyonları  
Terminal Box Positions  
Klemmenkasten Positionen

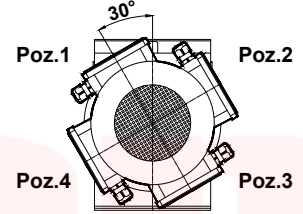

132-160-180-200-225-250  
Tip / Type / Typ

## KR773.05

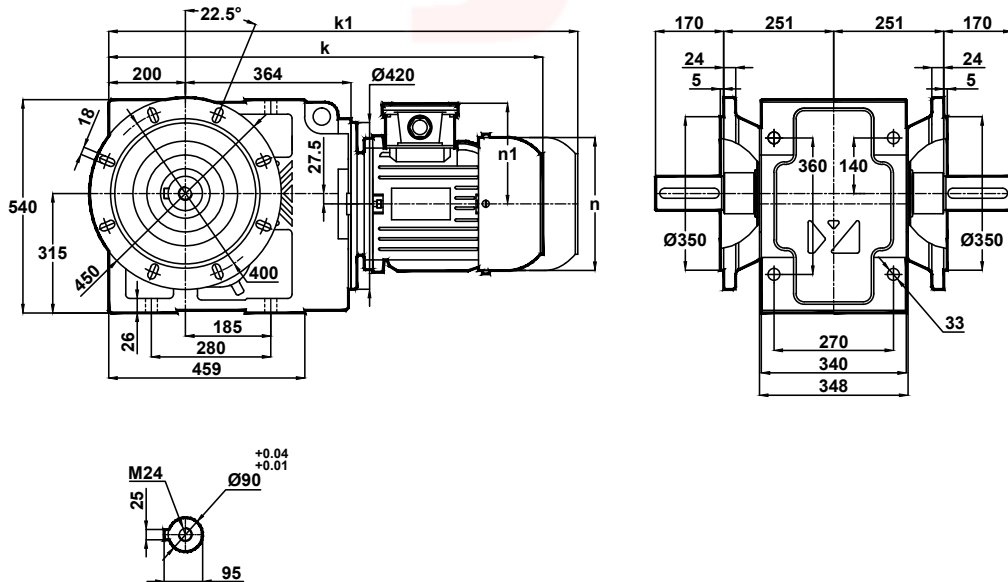

	132S	132M	160M	160L	180M	180L	200L	225S	225M	250M
k	938	976	1052	1096	1113	1151	1190	1217	1242	1346
k1	1083	1121	1222	1266	1283	1321	1390	-	-	-
n	258	258	310	310	348	348	390	433	433	480
n1	168	168	225	225	241	241	275	285	285	322



# Ölçü Sayfaları Dimension Pages Abmessungsseiten



-Mil ucu çektirme deliği DIN 332 sayfa 2 / Tapped center hole to DIN 332, sheet 2 / Zentrierung mit gewinde DIN 332, Blatt 2

KR773.08

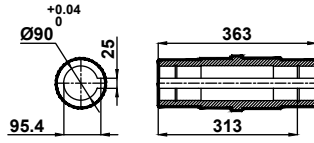
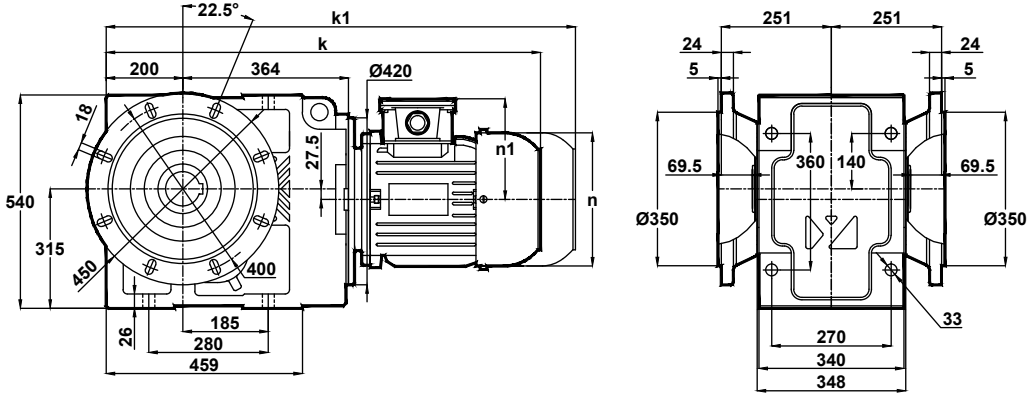

	132S	132M	160M	160L	180M	180L	200L	225S	225M	250M
k	938	976	1052	1096	1113	1151	1190	1217	1242	1346
k1	1083	1121	1222	1266	1283	1321	1390	-	-	-
n	258	258	310	310	348	348	390	433	433	480
n1	168	168	225	225	241	241	275	285	285	322

Klemens Pozisyonları  
Terminal Box Positions  
Klemmenkasten Positionen

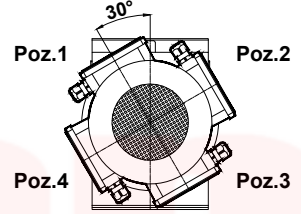

132-160-180-200-225-250  
Tip / Type / Typ



# Ölçü Sayfaları Dimension Pages Abmessungsseiten



-Mil ucu çekirme deliği DIN 332 sayfa 2 / Tapped center hole to DIN 332, sheet 2 / Zentrierung mit gewinde DIN 332, Blatt 2

## KR774.00

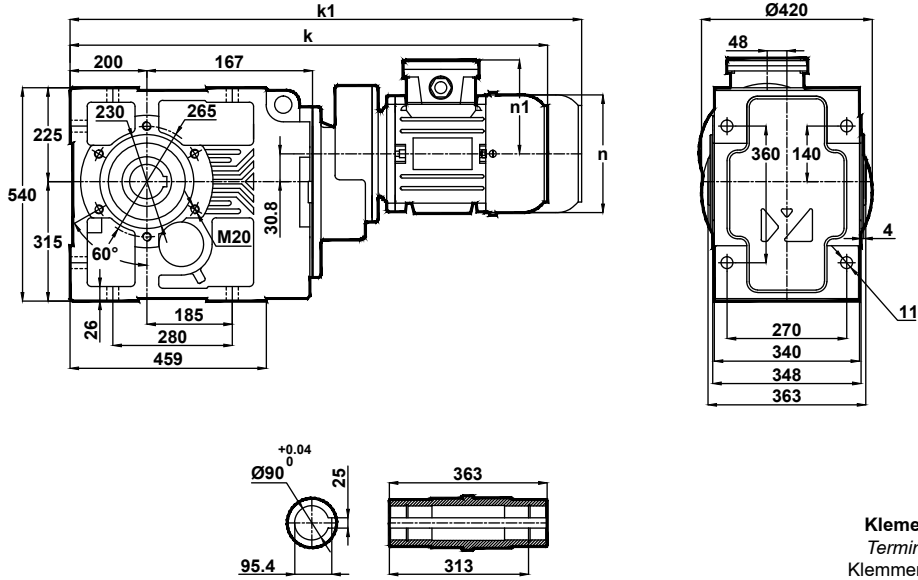

	90S	90L	100L	112M	132S	132M	160M	160L	180M	180L
k	908	945	971	1001	1046	1096	1158	1215	1227	1270
k1	1033	1070	1106	1136	1191	1241	1328	1385	1397	1440
n	176	176	194	218	258	258	310	310	348	348
n1	126	126	135	146	168	168	225	225	241	241

Klemens Pozisyonları  
Terminal Box Positions  
Klemmenkasten Positionen

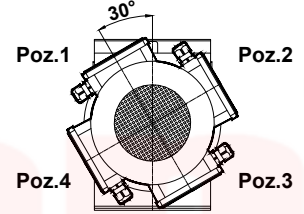

90-100-112-132-160-180  
Tip / Tvpe / Tvø

## KR774.01

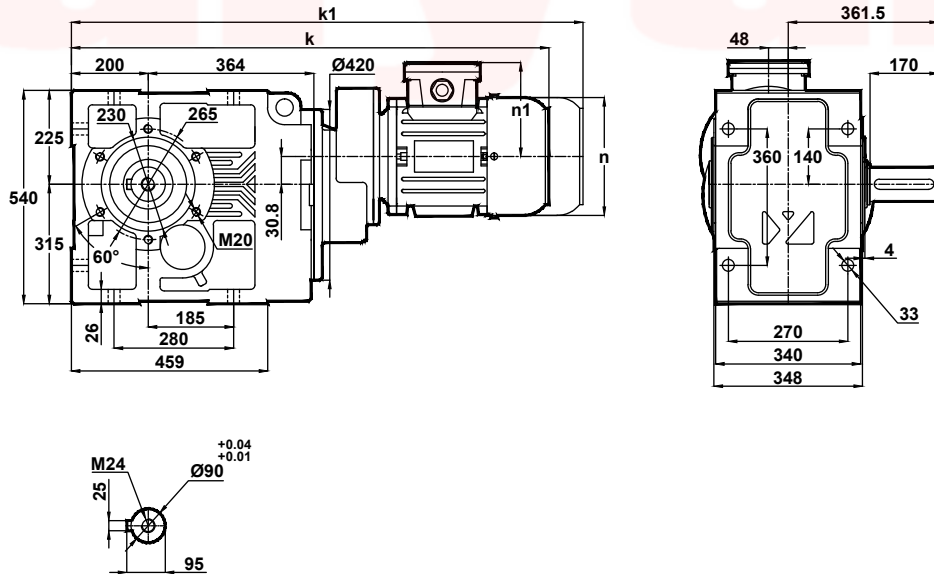

	90S	90L	100L	112M	132S	132M	160M	160L	180M	180L
k	908	945	971	1001	1046	1096	1158	1215	1227	1270
k1	1033	1070	1106	1136	1191	1241	1328	1385	1397	1440
n	176	176	194	218	258	258	310	310	348	348
n1	126	126	135	146	168	168	225	225	241	241



# Ölçü Sayfaları Dimension Pages Abmessungsseiten



-Mil ucu çektirme deliği DIN 332 sayfa 2 / Tapped center hole to DIN 332, sheet 2 / Zentrierung mit gewinde DIN 332, Blatt 2

## KR774.02

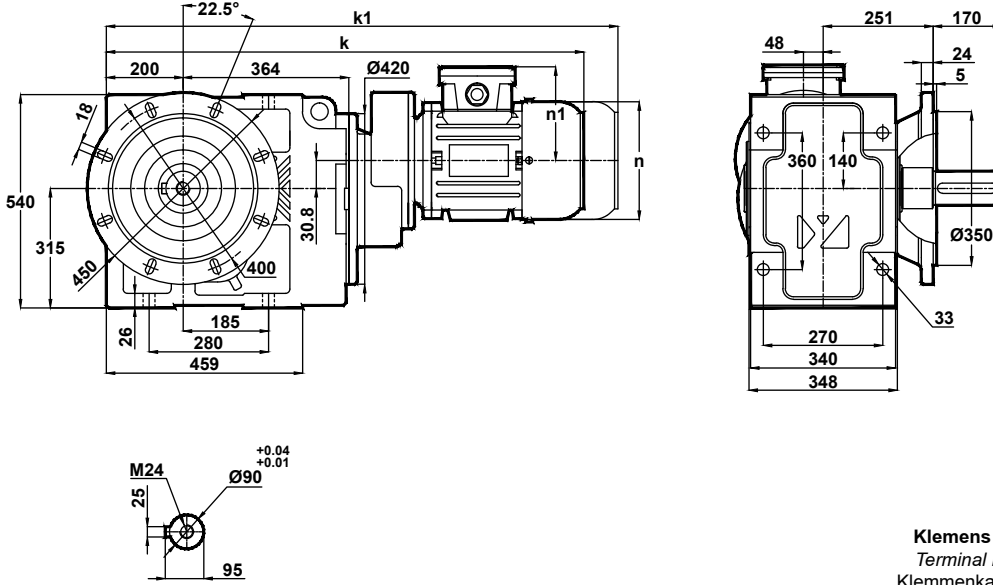

Klemens Pozisyonları  
Terminal Box Positions  
Klemmenkasten Positionen

	90S	90L	100L	112M	132S	132M	160M	160L	180M	180L
k	908	945	971	1001	1046	1096	1158	1215	1227	1270
k1	1033	1070	1106	1136	1191	1241	1328	1385	1397	1440
n	176	176	194	218	258	258	310	310	348	348
n1	126	126	135	146	168	168	225	225	241	241

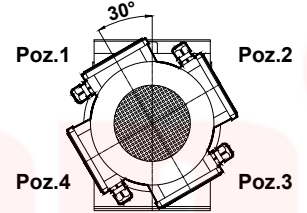

90-100-112-132-160-180  
Tip / Type / Typ

## KR774.03

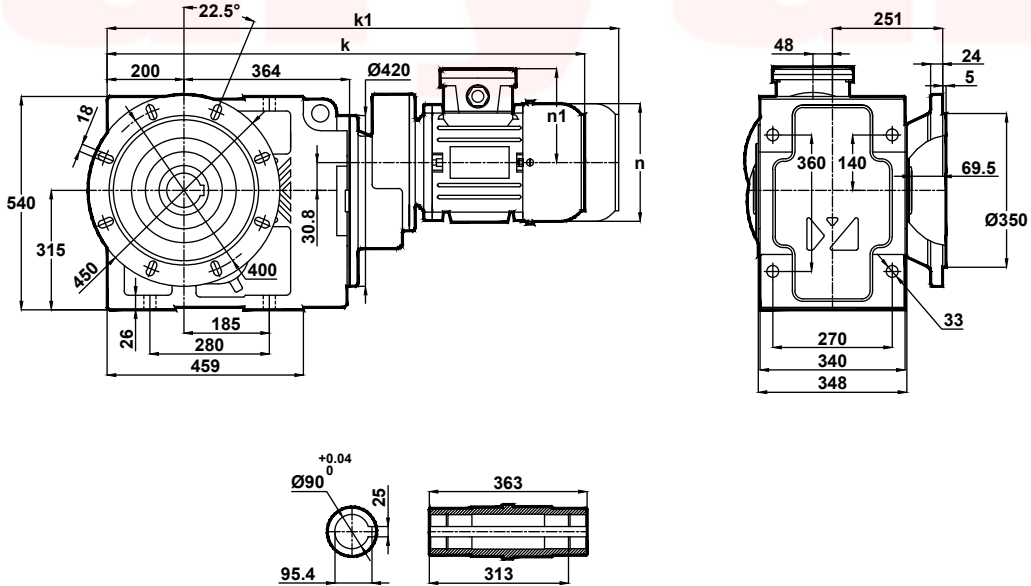

	90S	90L	100L	112M	132S	132M	160M	160L	180M	180L
k	908	945	971	1001	1046	1096	1158	1215	1227	1270
k1	1033	1070	1106	1136	1191	1241	1328	1385	1397	1440
n	176	176	194	218	258	258	310	310	348	348
n1	126	126	135	146	168	168	225	225	241	241



# Ölçü Sayfaları Dimension Pages Abmessungenseiten



-Mil ucu çekirme deliği DIN 332 sayfa 2 / Tapped center hole to DIN 332, sheet 2 / Zentrierung mit gewinde DIN 332, Blatt 2

## KR774.04

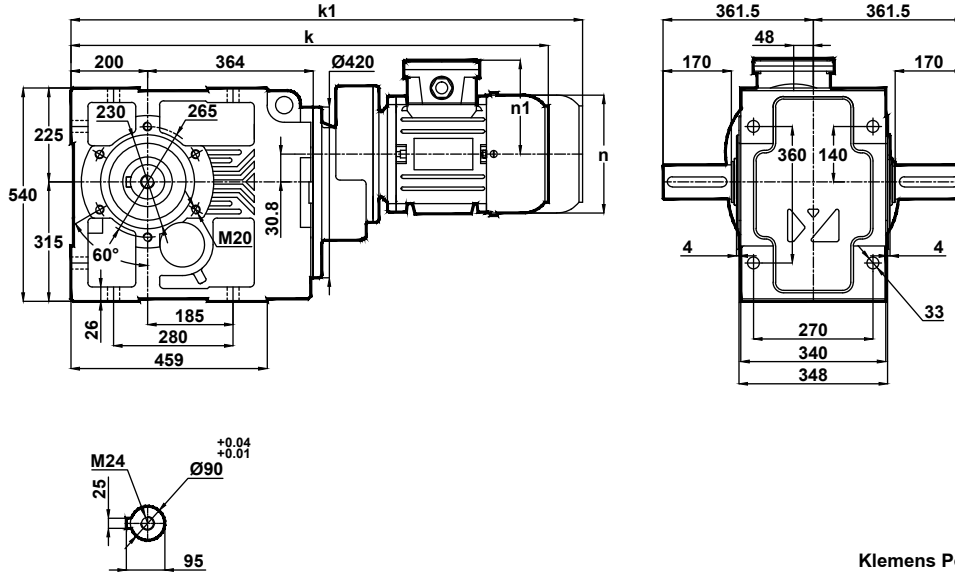

**Klemens Pozisyonları**  
Terminal Box Positions  
Klemmenkasten Positionen

	90S	90L	100L	112M	132S	132M	160M	160L	180M	180L
k	908	945	971	1001	1046	1096	1158	1215	1227	1270
k1	1033	1070	1106	1136	1191	1241	1328	1385	1397	1440
n	176	176	194	218	258	258	310	310	348	348
n1	126	126	135	146	168	168	225	225	241	241

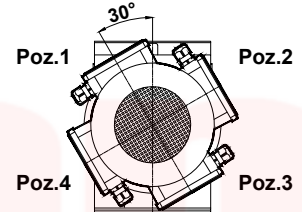

90-100-112-132-160-180  
Tip / Type / Typ

## KR774.05

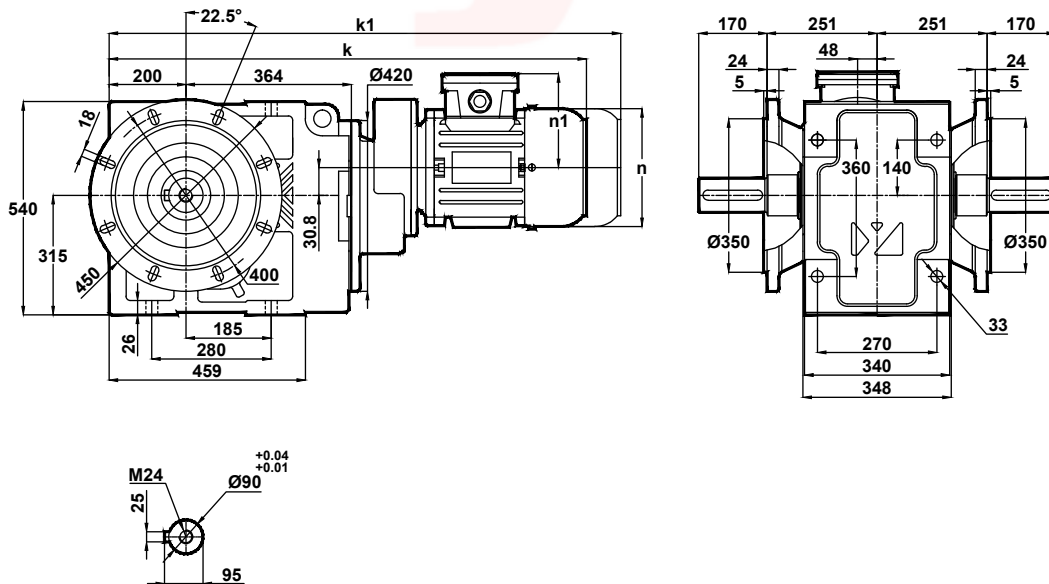

	90S	90L	100L	112M	132S	132M	160M	160L	180M	180L
k	908	945	971	1001	1046	1096	1158	1215	1227	1270
k1	1033	1070	1106	1136	1191	1241	1328	1385	1397	1440
n	176	176	194	218	258	258	310	310	348	348
n1	126	126	135	146	168	168	225	225	241	241



# Ölçü Sayfaları Dimension Pages Abmessungsseiten



-Mil ucu çektirme deliği DIN 332 sayfa 2 / Tapped center hole to DIN 332, sheet 2 / Zentrierung mit gewinde DIN 332, Blatt 2

KR774.08

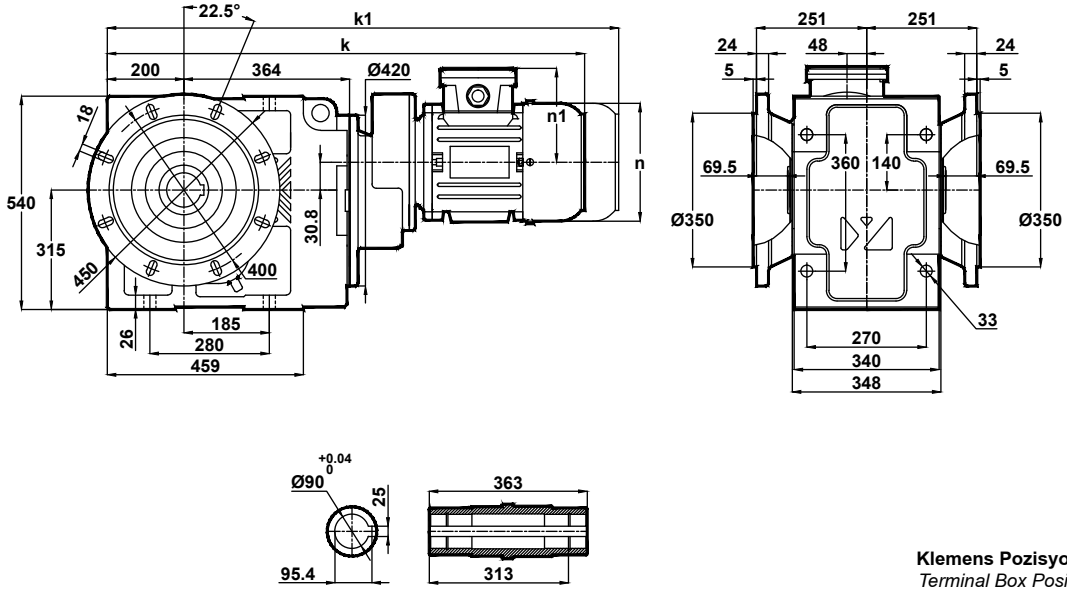

	90S	90L	100L	112M	132S	132M	160M	160L	180M	180L
k	908	945	971	1001	1046	1096	1158	1215	1227	1270
k1	1033	1070	1106	1136	1191	1241	1328	1385	1397	1440
n	176	176	194	218	258	258	310	310	348	348
n1	126	126	135	146	168	168	225	225	241	241

Klemens Pozisyonları  
Terminal Box Positions  
Klemmenkasten Positionen

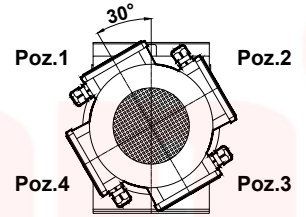

90-100-112-132-160-180-200  
Tip / Type / Typ



# Ölçü Sayfaları Dimension Pages Abmessungenseiten



-Mil ucu çekirme deliği DIN 332 sayfa 2 / Tapped center hole to DIN 332, sheet 2 / Zentrierung mit gewinde DIN 332, Blatt 2

KR775.00  
KR776.00

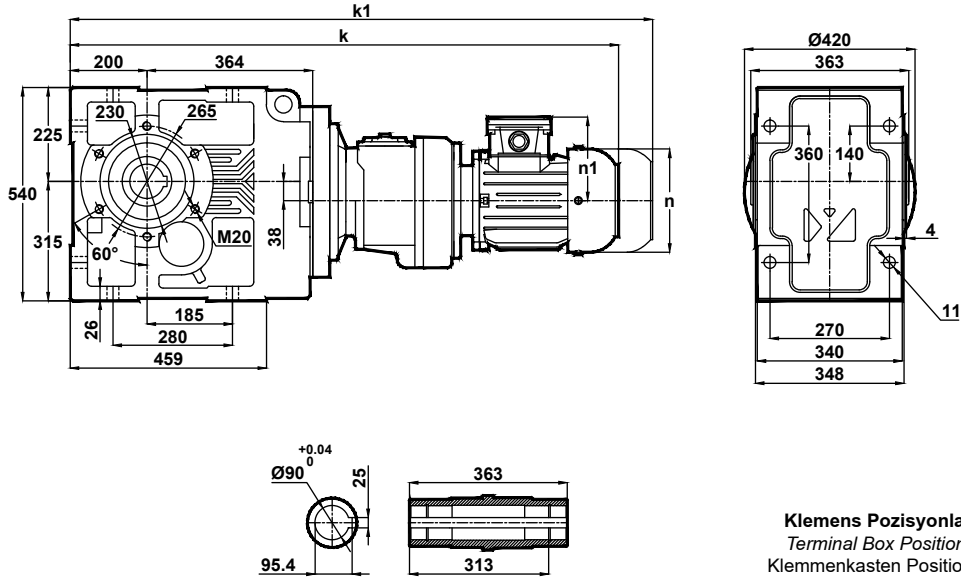

	71	80	90S	90L	100L	112M	132S	132M
k	1010	1038	1067	1092	1132	1155	1209	1247
k1	1130	1158	1192	1217	1267	1290	1354	1392
n	138	156	176	176	194	218	258	258
n1	110	118	126	126	135	146	168	168

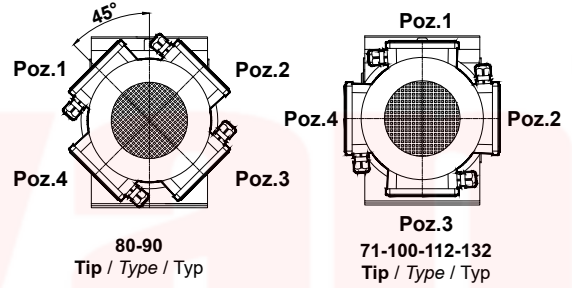

KR775.01  
KR776.01

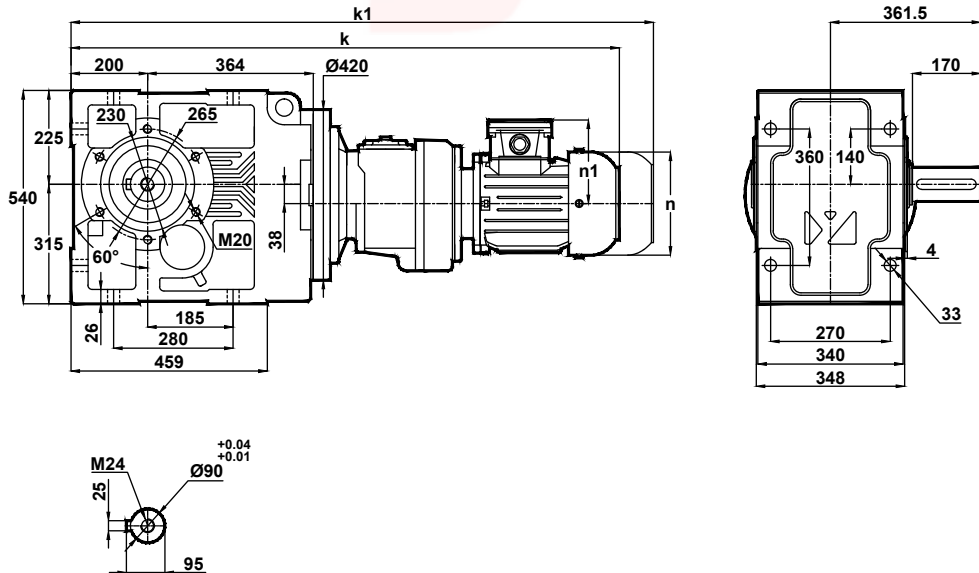

	71	80	90S	90L	100L	112M	132S	132M
k	1010	1038	1067	1092	1132	1155	1209	1247
k1	1130	1158	1192	1217	1267	1290	1354	1392
n	138	156	176	176	194	218	258	258
n1	110	118	126	126	135	146	168	168





# Ölçü Sayfaları Dimension Pages Abmessungsseiten



-Mil ucu çektirme deliği DIN 332 sayfa 2 / Tapped center hole to DIN 332, sheet 2 / Zentrierung mit gewinde DIN 332, Blatt 2

KR775.02  
KR776.02

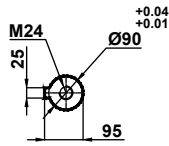
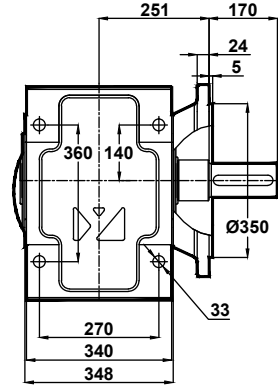
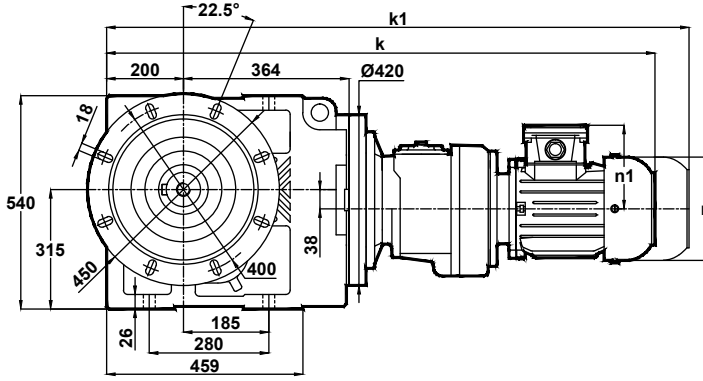

Klemens Pozisyonları  
Terminal Box Positions  
Klemmenkasten Positionen

	71	80	90S	90L	100L	112M	132S	132M
k	1010	1038	1067	1092	1132	1155	1209	1247
k1	1130	1158	1192	1217	1267	1290	1354	1392
n	138	156	176	176	194	218	258	258
n1	110	118	126	126	135	146	168	168

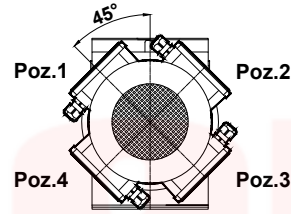

80-90  
Tip / Type / Typ

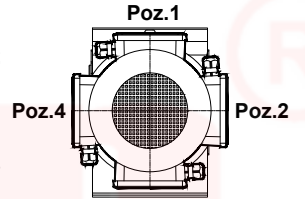

71-100-112-132  
Tip / Type / Typ

KR775.03  
KR776.03

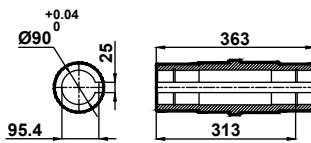
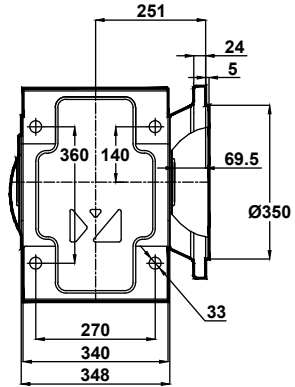
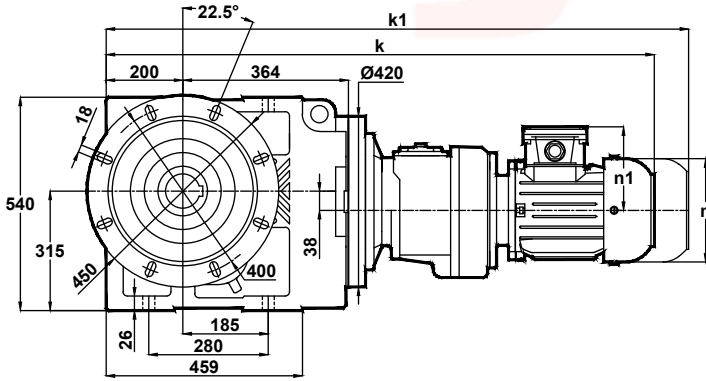

	71	80	90S	90L	100L	112M	132S	132M
k	1010	1038	1067	1092	1132	1155	1209	1247
k1	1130	1158	1192	1217	1267	1290	1354	1392
n	138	156	176	176	194	218	258	258
n1	110	118	126	126	135	146	168	168



# Ölçü Sayfaları Dimension Pages Abmessungsseiten



-Mil ucu çektirme deliği DIN 332 sayfa 2 / Tapped center hole to DIN 332, sheet 2 / Zentrierung mit gewinde DIN 332, Blatt 2

KR775.04  
KR776.04

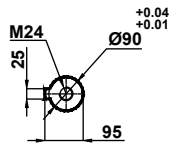
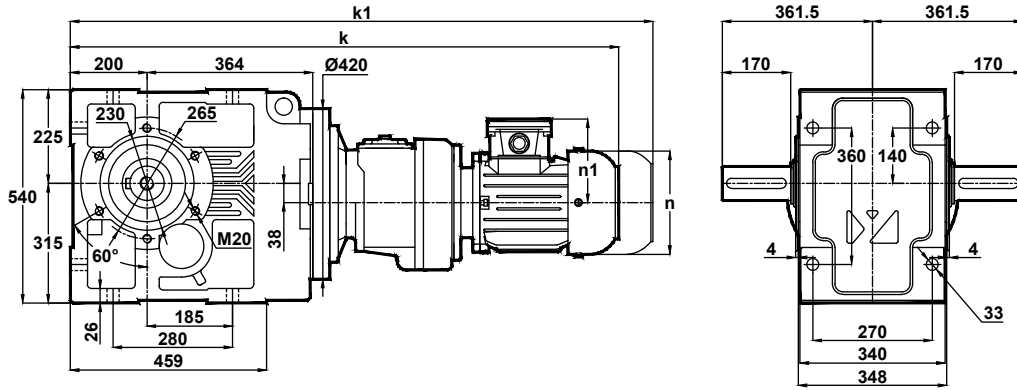

Klemens Pozisyonları  
Terminal Box Positions  
Klemmenkasten Positionen

	71	80	90S	90L	100L	112M	132S	132M
k	1010	1038	1067	1092	1132	1155	1209	1247
k1	1130	1158	1192	1217	1267	1290	1354	1392
n	138	156	176	176	194	218	258	258
n1	110	118	126	126	135	146	168	168

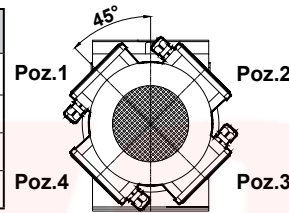

80-90  
Tip / Type / Typ

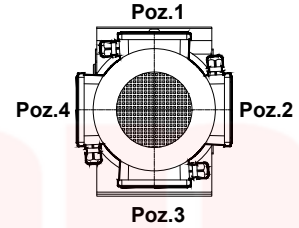

71-100-112-132  
Tip / Type / Typ

KR775.05  
KR776.05

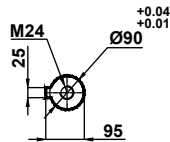
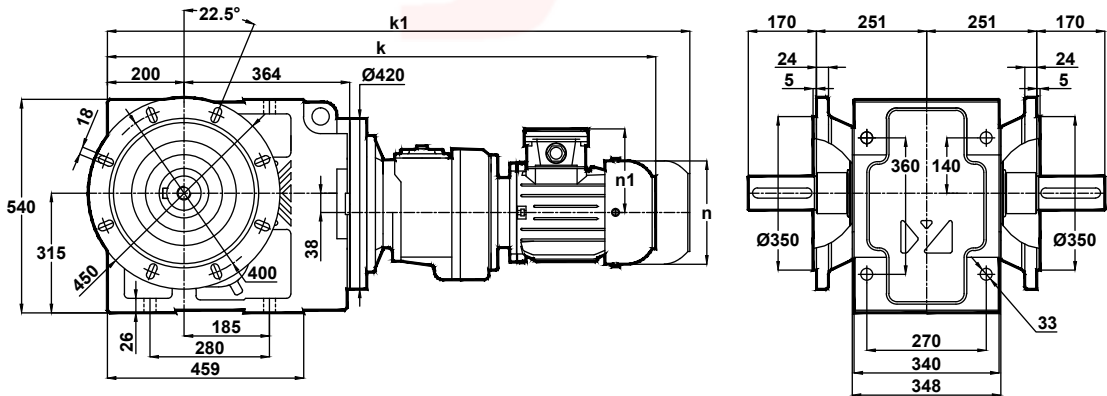

	71	80	90S	90L	100L	112M	132S	132M
k	1010	1038	1067	1092	1132	1155	1209	1247
k1	1130	1158	1192	1217	1267	1290	1354	1392
n	138	156	176	176	194	218	258	258
n1	110	118	126	126	135	146	168	168



# Ölçü Sayfaları Dimension Pages Abmessungenseiten



-Mil ucu çektirme deliği DIN 332 sayfa 2 / Tapped center hole to DIN 332, sheet 2 / Zentrierung mit gewinde DIN 332, Blatt 2

KR775.08  
KR776.08

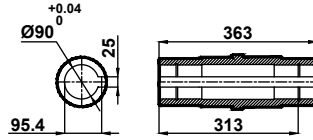
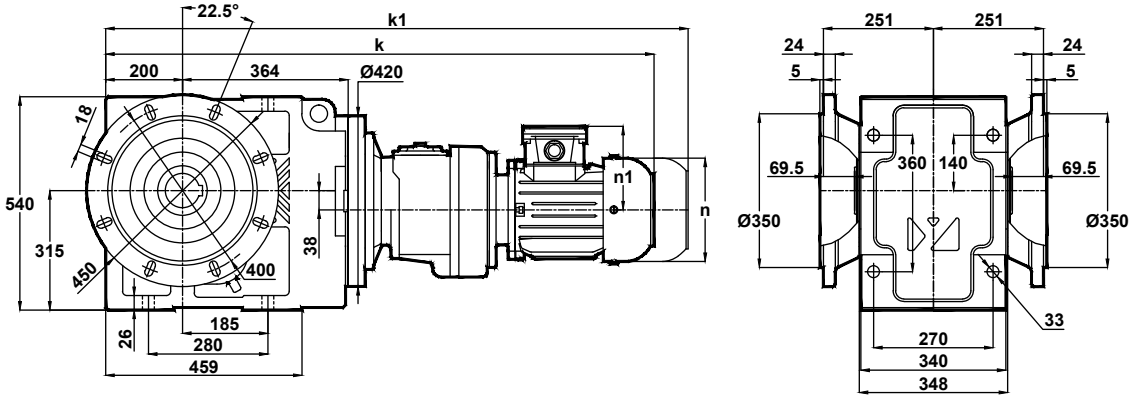

Klemens Pozisyonları  
Terminal Box Positions  
Klemmenkasten Positionen

	71	80	90S	90L	100L	112M	132S	132M
k	1010	1038	1067	1092	1132	1155	1209	1247
k1	1130	1158	1192	1217	1267	1290	1354	1392
n	138	156	176	176	194	218	258	258
n1	110	118	126	126	135	146	168	168

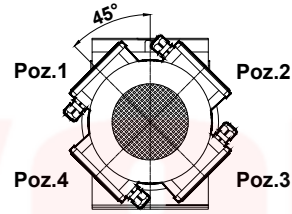

80-90  
Tip / Type / Typ

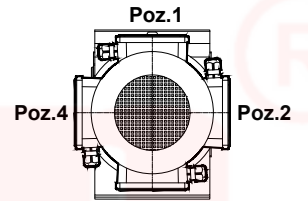

71-100-112-132  
Tip / Type / Typ



# Ölçü Sayfaları Dimension Pages Abmessungenseiten



-Mil ucu çekirme deliği DIN 332 sayfa 2 / Tapped center hole to DIN 332, sheet 2 / Zentrierung mit gewinde DIN 332, Blatt 2

## KR873.00

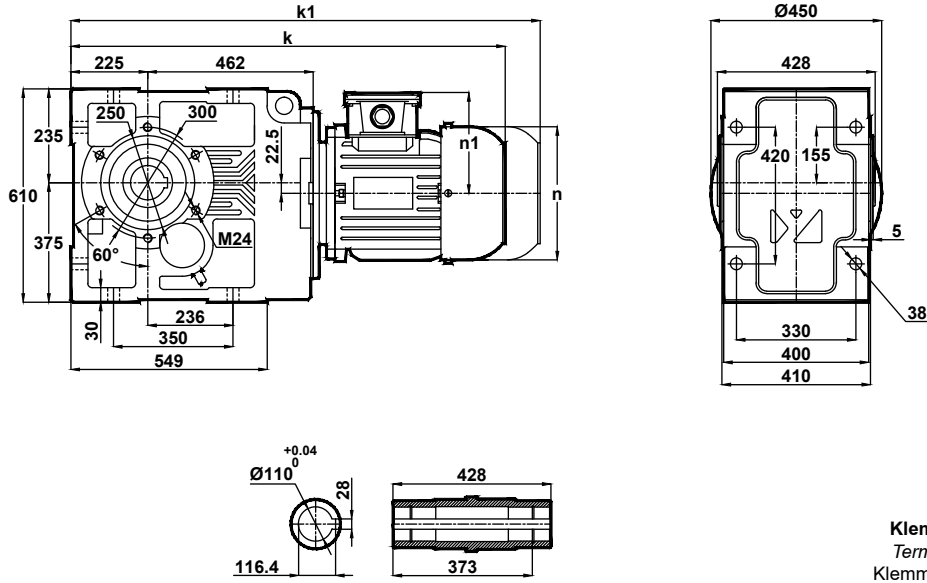

**Klemens Pozisyonları**  
Terminal Box Positions  
Klemmenkasten Positionen

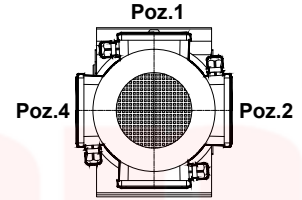

**Poz.3**  
132-160-180-200-225-250-280  
Tip / Type / Typ

	132S	132M	160M	160L	180M	180L	200L	225S	225M	250M	280S	280M
<b>k</b>	1050	1088	1156	1200	1216	1254	1293	1309	1334	1437	1498	1498
<b>k1</b>	1195	1233	1326	1370	1386	1424	1493	-	-	-	-	-
<b>n</b>	258	258	310	310	348	348	390	433	433	480	544	544
<b>n1</b>	168	168	225	225	241	241	275	285	285	322	350	350

## KR873.01

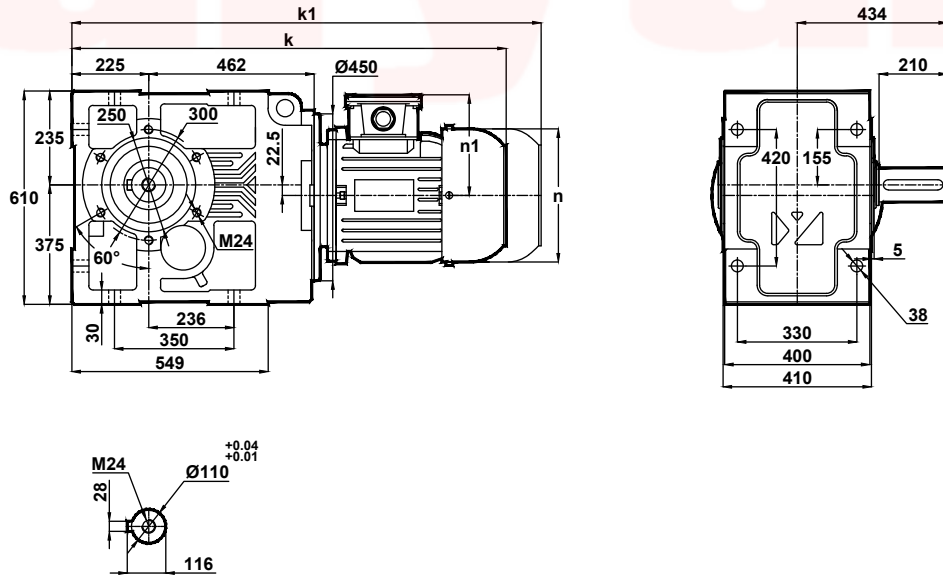

	132S	132M	160M	160L	180M	180L	200L	225S	225M	250M	280S	280M
<b>k</b>	1050	1088	1156	1200	1216	1254	1293	1309	1334	1437	1498	1498
<b>k1</b>	1195	1233	1326	1370	1386	1424	1493	-	-	-	-	-
<b>n</b>	258	258	310	310	348	348	390	433	433	480	544	544
<b>n1</b>	168	168	225	225	241	241	275	285	285	322	350	350



# Ölçü Sayfaları Dimension Pages Abmessungsseiten



-Mil ucu çektirme deliği DIN 332 sayfa 2 / Tapped center hole to DIN 332, sheet 2 / Zentrierung mit gewinde DIN 332, Blatt 2

## KR873.02

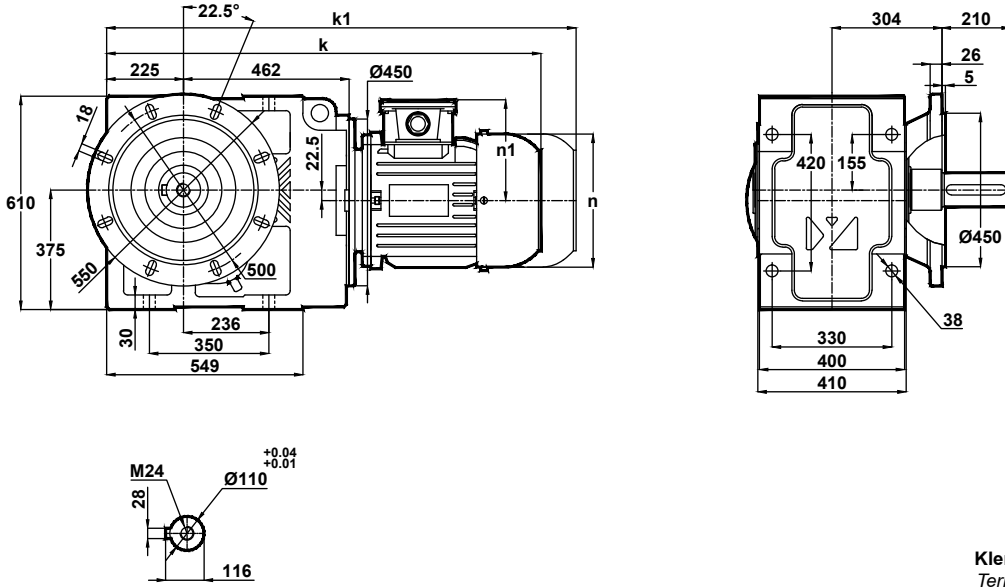

Klemens Pozisyonları  
Terminal Box Positions  
Klemmenkasten Positionen

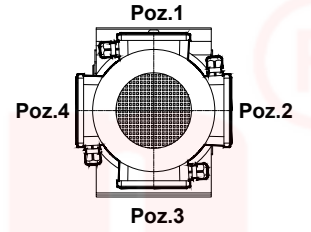

132-160-180-200-225-250-280  
Tip / Type / Typ

	132S	132M	160M	160L	180M	180L	200L	225S	225M	250M	280S	280M
k	1050	1088	1156	1200	1216	1254	1293	1309	1334	1437	1498	1498
k1	1195	1233	1326	1370	1386	1424	1493	-	-	-	-	-
n	258	258	310	310	348	348	390	433	433	480	544	544
n1	168	168	225	225	241	241	275	285	285	322	350	350

## KR873.03

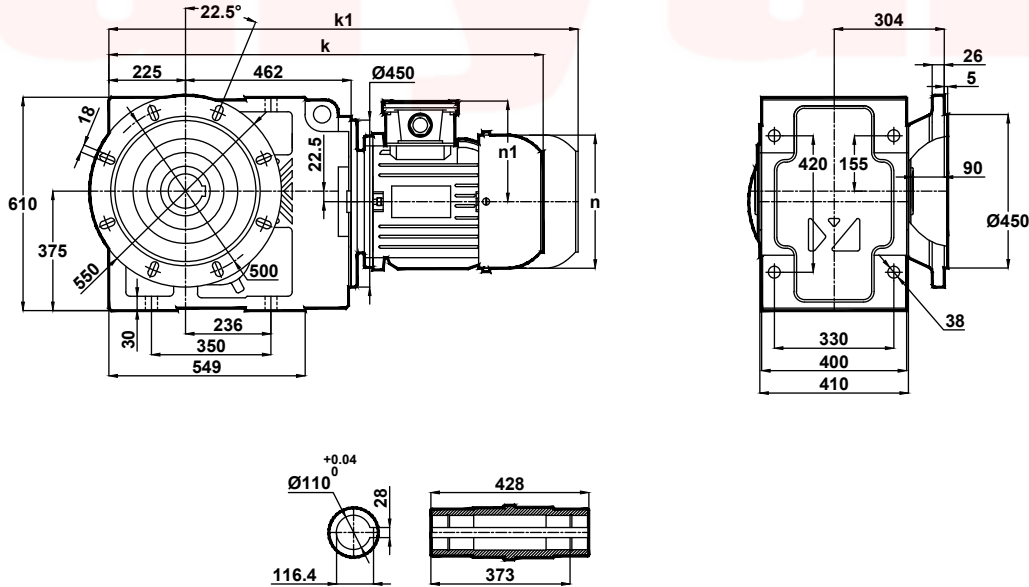

	132S	132M	160M	160L	180M	180L	200L	225S	225M	250M	280S	280M
k	1050	1088	1156	1200	1216	1254	1293	1309	1334	1437	1498	1498
k1	1195	1233	1326	1370	1386	1424	1493	-	-	-	-	-
n	258	258	310	310	348	348	390	433	433	480	544	544
n1	168	168	225	225	241	241	275	285	285	322	350	350



# Ölçü Sayfaları Dimension Pages Abmessungsseiten



-Mil ucu çekirme deliği DIN 332 sayfa 2 / Tapped center hole to DIN 332, sheet 2 / Zentrierung mit gewinde DIN 332, Blatt 2

## KR873.04

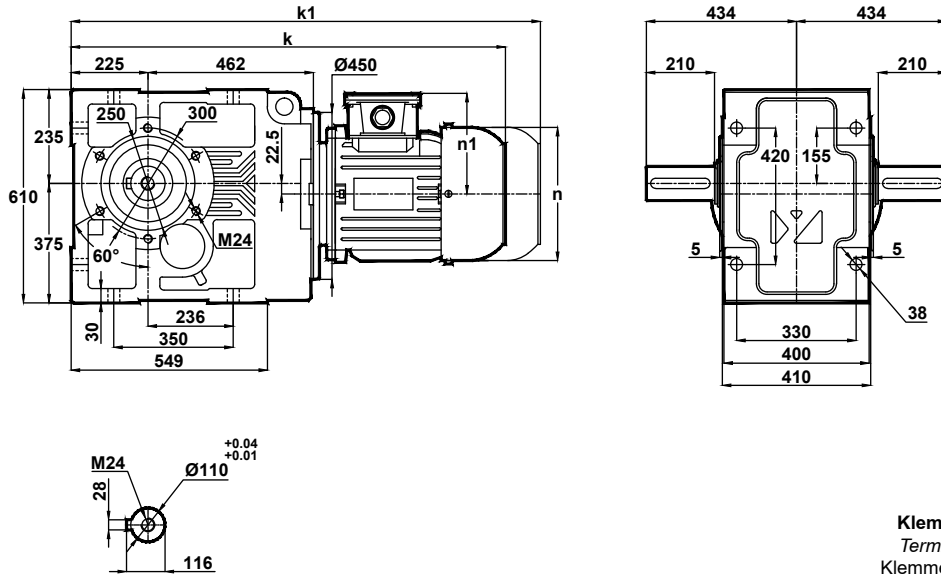

Klemens Pozisyonları  
Terminal Box Positions  
Klemmenkasten Positionen

	132S	132M	160M	160L	180M	180L	200L	225S	225M	250M	280S	280M
k	1050	1088	1156	1200	1216	1254	1293	1309	1334	1437	1498	1498
k1	1195	1233	1326	1370	1386	1424	1493	-	-	-	-	-
n	258	258	310	310	348	348	390	433	433	480	544	544
n1	168	168	225	225	241	241	275	285	285	322	350	350

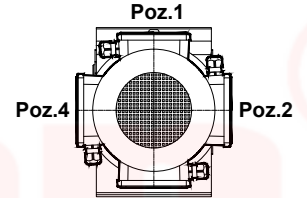

Poz.1  
Poz.2  
Poz.3  
Poz.4  
132-160-180-200-225-250-280  
Tip / Type / Typ

## KR873.05

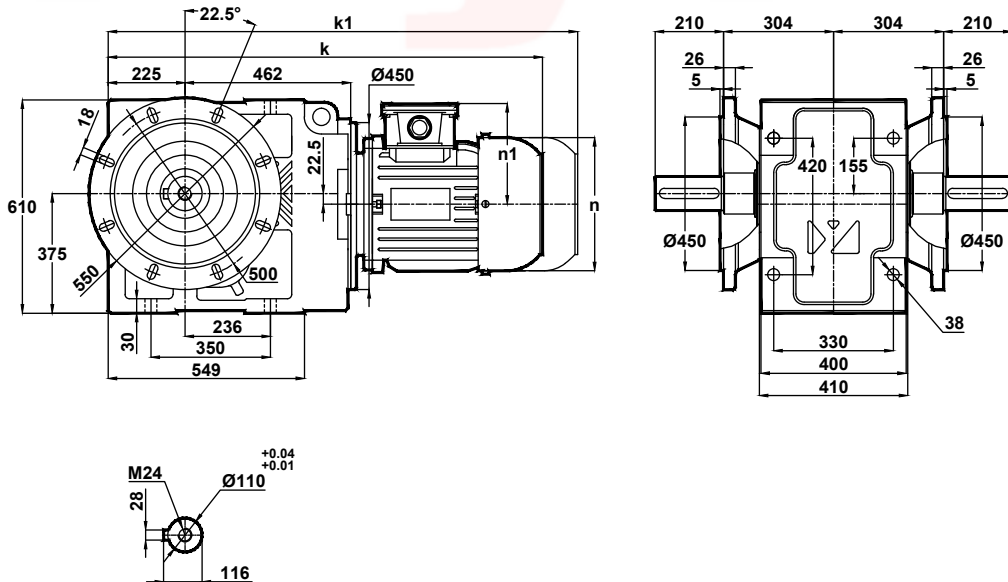

	132S	132M	160M	160L	180M	180L	200L	225S	225M	250M	280S	280M
k	1050	1088	1156	1200	1216	1254	1293	1309	1334	1437	1498	1498
k1	1195	1233	1326	1370	1386	1424	1493	-	-	-	-	-
n	258	258	310	310	348	348	390	433	433	480	544	544
n1	168	168	225	225	241	241	275	285	285	322	350	350



# Ölçü Sayfaları Dimension Pages Abmessungenseiten



-Mil ucu çektirme deliği DIN 332 sayfa 2 / Tapped center hole to DIN 332, sheet 2 / Zentrierung mit gewinde DIN 332, Blatt 2

KR873.08

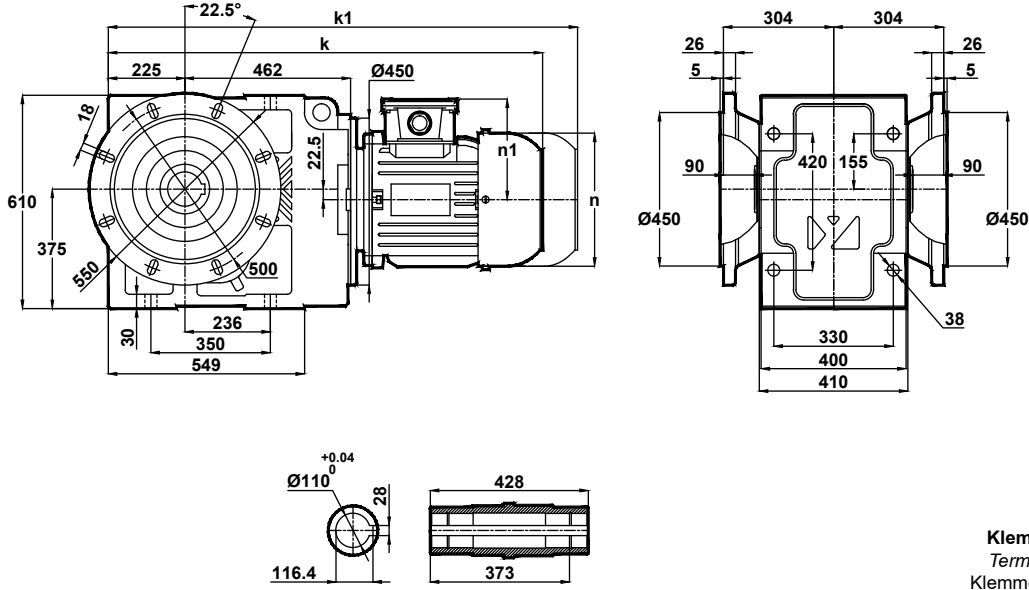

Klemens Pozisyonları  
Terminal Box Positions  
Klemmenkasten Positionen

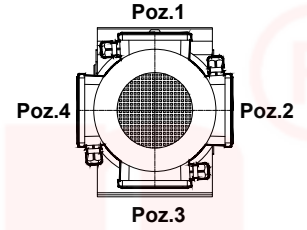

132-160-180-200-225-250-280  
Tip / Type / Typ

	132S	132M	160M	160L	180M	180L	200L	225S	225M	250M	280S	280M
k	1050	1088	1156	1200	1216	1254	1293	1309	1334	1437	1498	1498
k1	1195	1233	1326	1370	1386	1424	1493	-	-	-	-	-
n	258	258	310	310	348	348	390	433	433	480	544	544
n1	168	168	225	225	241	241	275	285	285	322	350	350



# Ölçü Sayfaları Dimension Pages Abmessungenseiten



-Mil ucu çekirme deliği DIN 332 sayfa 2 / Tapped center hole to DIN 332, sheet 2 / Zentrierung mit gewinde DIN 332, Blatt 2

## KR874.00

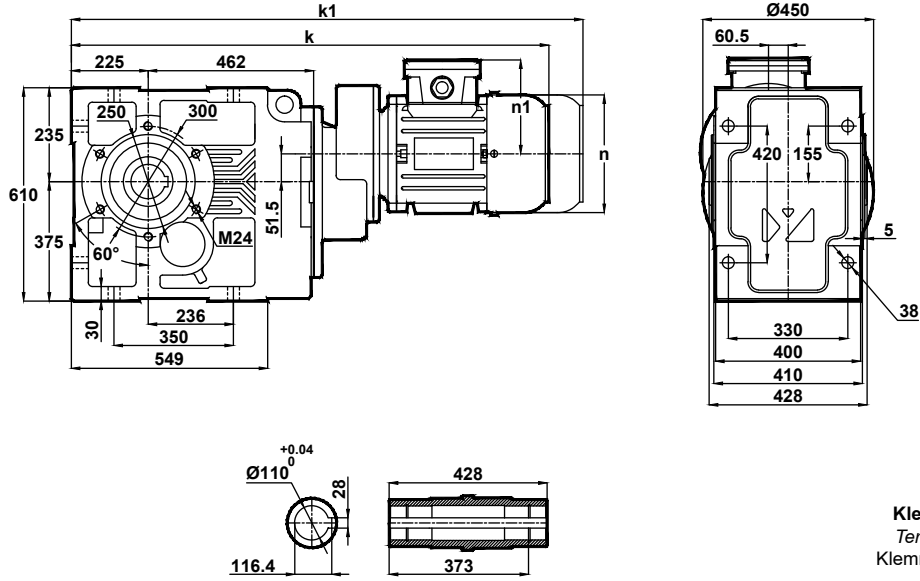

	100L	112M	132S	132M	160M	160L	180M	180L	200L
k	1115.5	1138.5	1192.5	1230.5	1305.5	1349.5	1366	1404	1443
k1	1250.5	1273.5	1337.5	1375.5	1475.5	1519.5	1536	1574	1643
n	194	218	258	258	310	310	348	348	390
n1	135	146	168	168	225	225	241	241	275

Klemens Pozisyonları  
Terminal Box Positions  
Klemmenkasten Positionen

Poz.1

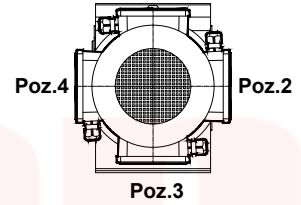

Poz.3

100-112-132-160-180-200  
Tip / Type / Typ

## KR874.01

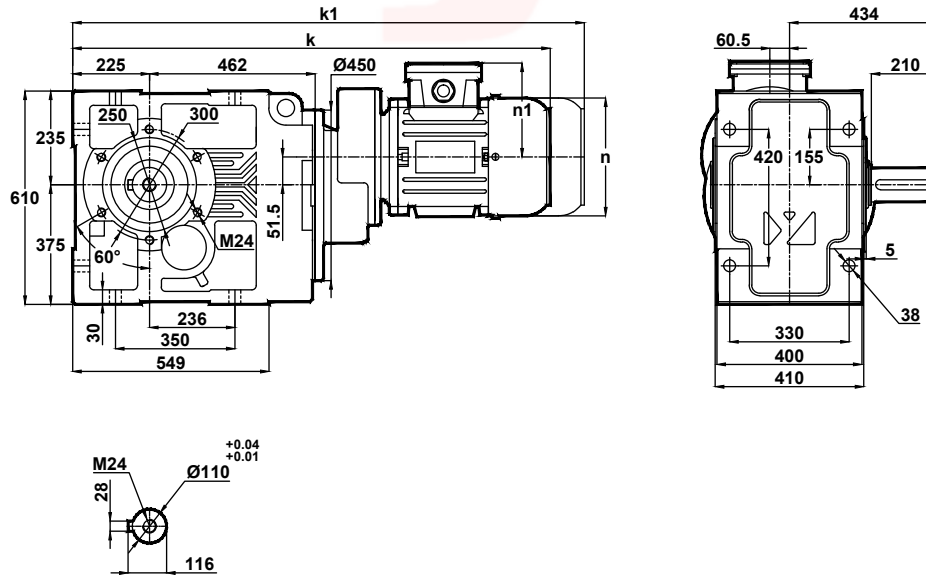

	100L	112M	132S	132M	160M	160L	180M	180L	200L
k	1115.5	1138.5	1192.5	1230.5	1305.5	1349.5	1366	1404	1443
k1	1250.5	1273.5	1337.5	1375.5	1475.5	1519.5	1536	1574	1643
n	194	218	258	258	310	310	348	348	390
n1	135	146	168	168	225	225	241	241	275





# Ölçü Sayfaları Dimension Pages Abmessungsseiten



-Mil ucu çektirme deliği DIN 332 sayfa 2 / Tapped center hole to DIN 332, sheet 2 / Zentrierung mit gewinde DIN 332, Blatt 2

## KR874.02

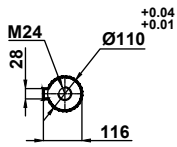
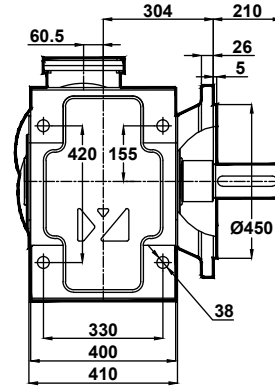
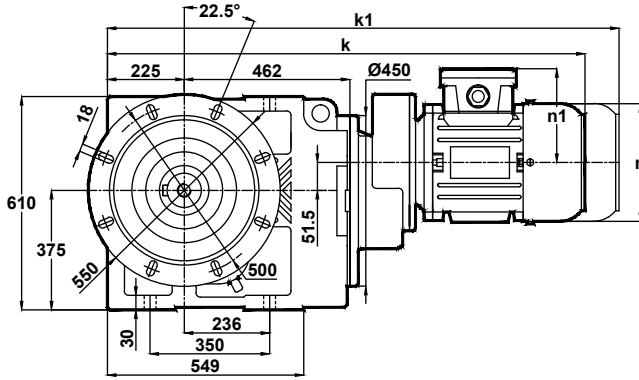

	100L	112M	132S	132M	160M	160L	180M	180L	200L
k	1115.5	1138.5	1192.5	1230.5	1305.5	1349.5	1366	1404	1443
k1	1250.5	1273.5	1337.5	1375.5	1475.5	1519.5	1536	1574	1643
n	194	218	258	258	310	310	348	348	390
n1	135	146	168	168	225	225	241	241	275

Klemens Pozisyonları  
Terminal Box Positions  
Klemmenkasten Positionen

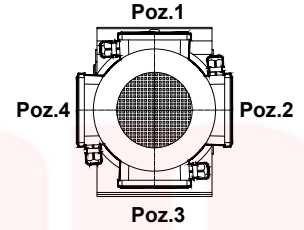

100-112-132-160-180-200  
Tip / Type / Typ

## KR874.03

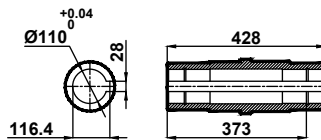
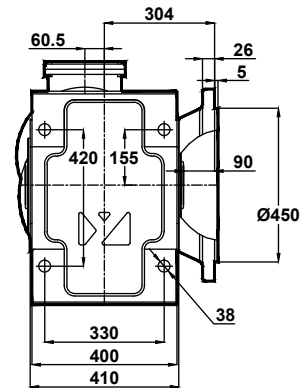
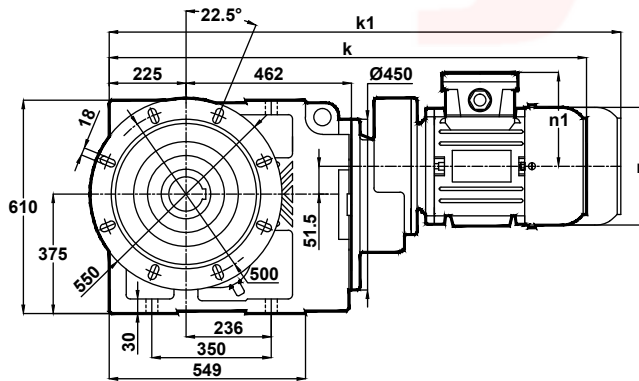

	100L	112M	132S	132M	160M	160L	180M	180L	200L
k	1115.5	1138.5	1192.5	1230.5	1305.5	1349.5	1366	1404	1443
k1	1250.5	1273.5	1337.5	1375.5	1475.5	1519.5	1536	1574	1643
n	194	218	258	258	310	310	348	348	390
n1	135	146	168	168	225	225	241	241	275



# Ölçü Sayfaları Dimension Pages Abmessungenseiten



-Mil ucu çekirme deliği DIN 332 sayfa 2 / Tapped center hole to DIN 332, sheet 2 / Zentrierung mit gewinde DIN 332, Blatt 2

## KR874.04

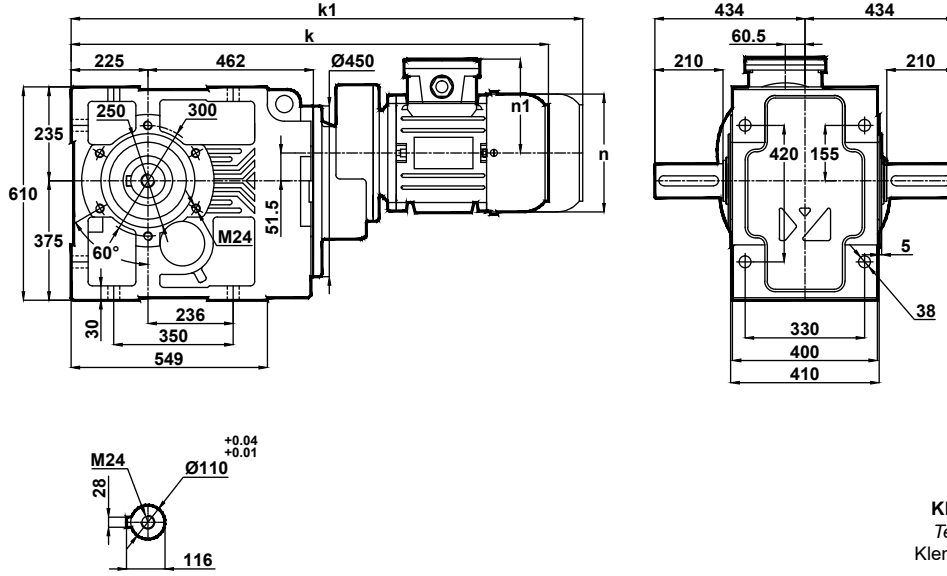

	100L	112M	132S	132M	160M	160L	180M	180L	200L
k	1115.5	1138.5	1192.5	1230.5	1305.5	1349.5	1366	1404	1443
k1	1250.5	1273.5	1337.5	1375.5	1475.5	1519.5	1536	1574	1643
n	194	218	258	258	310	310	348	348	390
n1	135	146	168	168	225	225	241	241	275

Klemens Pozisyonları  
Terminal Box Positions  
Klemmenkasten Positionen

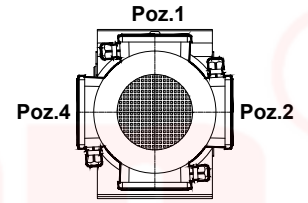

Poz.3  
100-112-132-160-180-200  
Tip / Type / Typ

## KR874.05

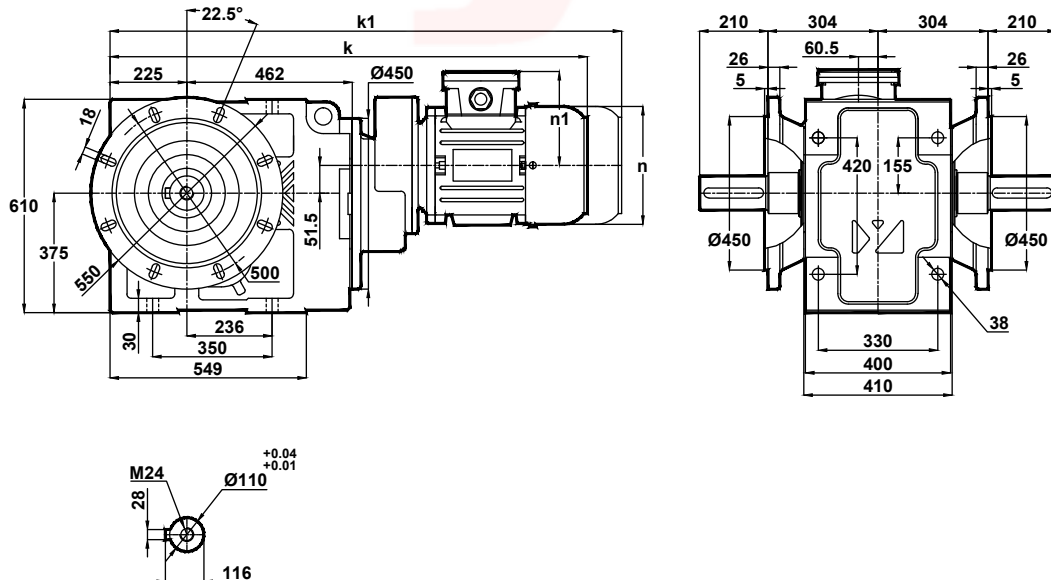

	100L	112M	132S	132M	160M	160L	180M	180L	200L
k	1115.5	1138.5	1192.5	1230.5	1305.5	1349.5	1366	1404	1443
k1	1250.5	1273.5	1337.5	1375.5	1475.5	1519.5	1536	1574	1643
n	194	218	258	258	310	310	348	348	390
n1	135	146	168	168	225	225	241	241	275



# Ölçü Sayfaları

## Dimension Pages

### Abmessungsseiten



-Mil ucu çektirme deliği DIN 332 sayfa 2 / Tapped center hole to DIN 332, sheet 2 / Zentrierung mit gewinde DIN 332, Blatt 2

KR874.08

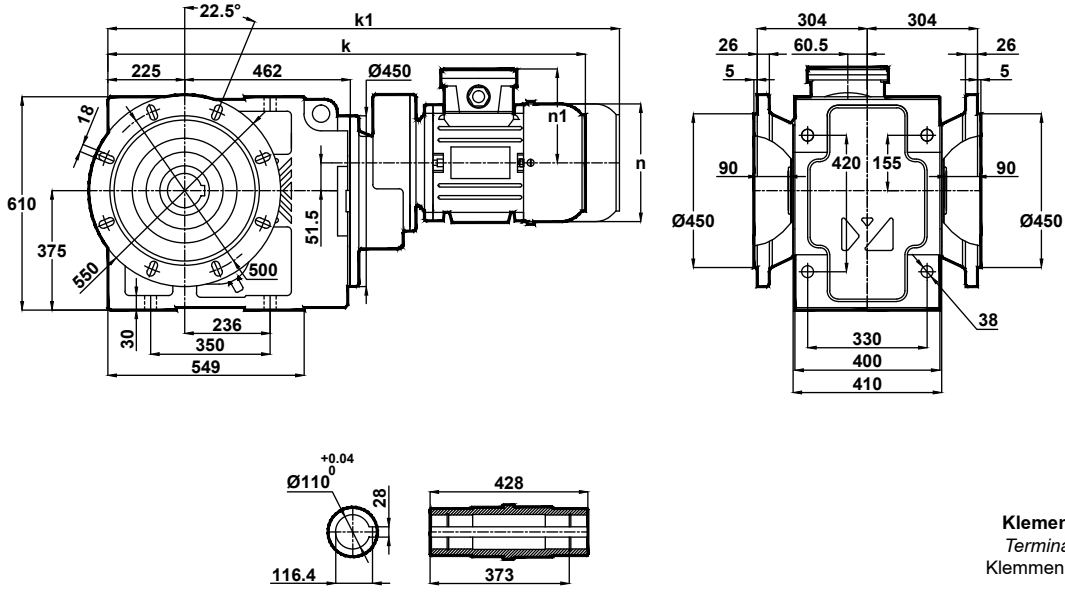

Klemens Pozisyonları  
Terminal Box Positions  
Klemmenkasten Positionen

	100L	112M	132S	132M	160M	160L	180M	180L	200L
k	1115.5	1138.5	1192.5	1230.5	1305.5	1349.5	1366	1404	1443
k1	1250.5	1273.5	1337.5	1375.5	1475.5	1519.5	1536	1574	1643
n	194	218	258	258	310	310	348	348	390
n1	135	146	168	168	225	225	241	241	275

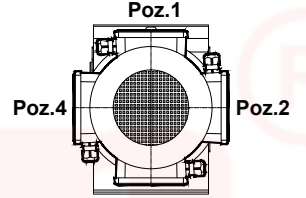

Poz.1  
Poz.2  
Poz.3  
Poz.4  
100-112-132-160-180-200  
Tip / Type / Typ



# Ölçü Sayfaları Dimension Pages Abmessungenseiten



-Mil ucu çektirme deliği DIN 332 sayfa 2 / Tapped center hole to DIN 332, sheet 2 / Zentrierung mit gewinde DIN 332, Blatt 2

KR875.00  
KR876.00

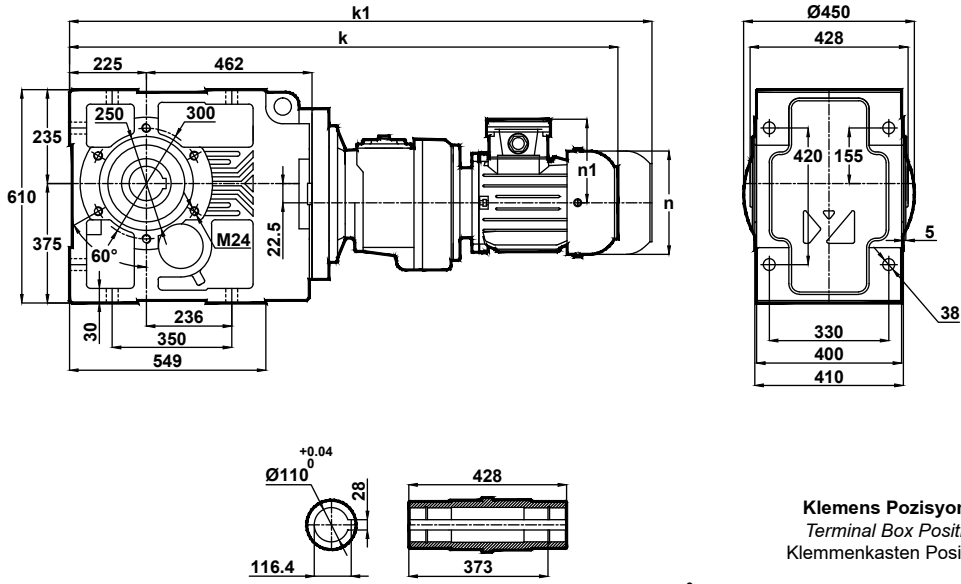

Klemens Pozisyonları  
Terminal Box Positions  
Klemmenkasten Positionen

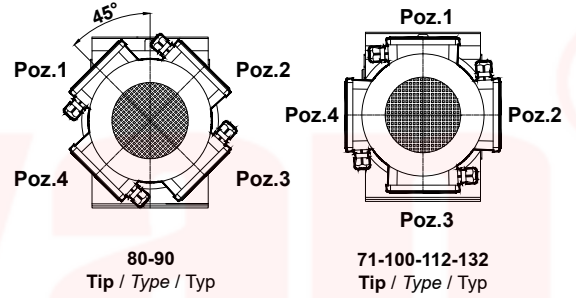

	71	80	90S	90L	100L	112M	132S	132M
k	1133	1161	1190	1215	1255	1278	1332	1370
k1	1255	1281	1315	1340	1390	1413	1477	1515
n	138	156	176	176	194	218	258	258
n1	110	118	126	126	135	146	168	168

KR875.01  
KR876.01

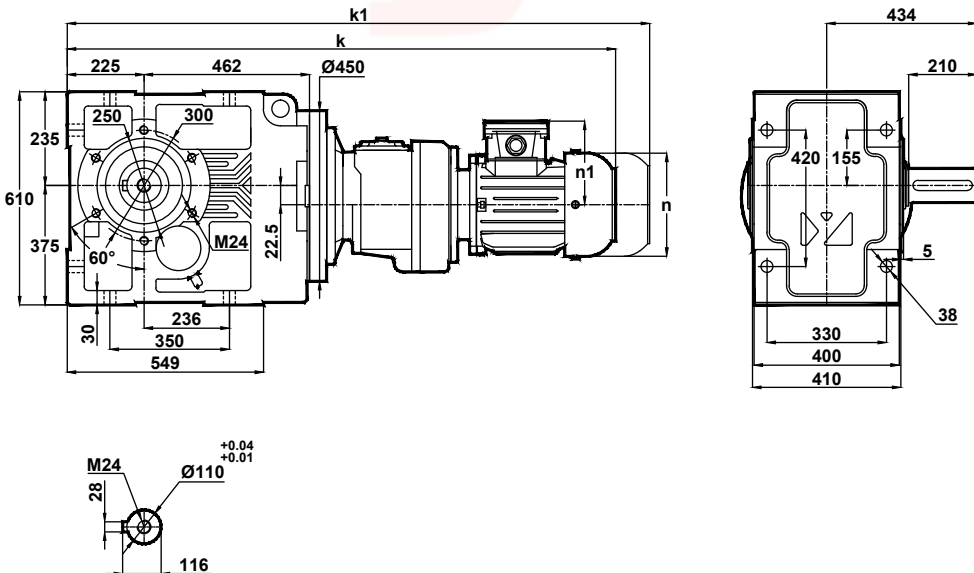

	71	80	90S	90L	100L	112M	132S	132M
k	1133	1161	1190	1215	1255	1278	1332	1370
k1	1255	1281	1315	1340	1390	1413	1477	1515
n	138	156	176	176	194	218	258	258
n1	110	118	126	126	135	146	168	168



# Ölçü Sayfaları

## Dimension Pages

### Abmessungsseiten



-Mil ucu çektirme deliği DIN 332 sayfa 2 / Tapped center hole to DIN 332, sheet 2 / Zentrierung mit gewinde DIN 332, Blatt 2

KR875.02  
KR876.02

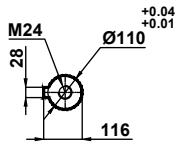
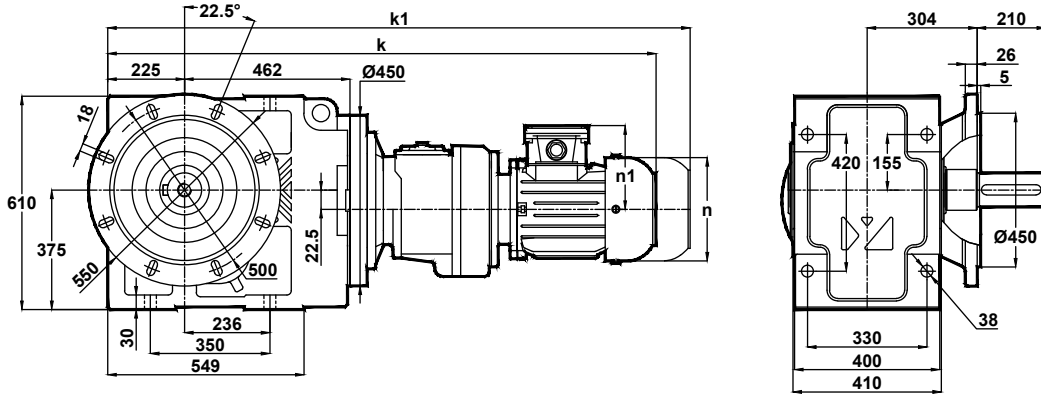

	71	80	90S	90L	100L	112M	132S	132M
k	1133	1161	1190	1215	1255	1278	1332	1370
k1	1255	1281	1315	1340	1390	1413	1477	1515
n	138	156	176	176	194	218	258	258
n1	110	118	126	126	135	146	168	168

Klemens Pozisyonları  
Terminal Box Positions  
Klemmenkasten Positionen

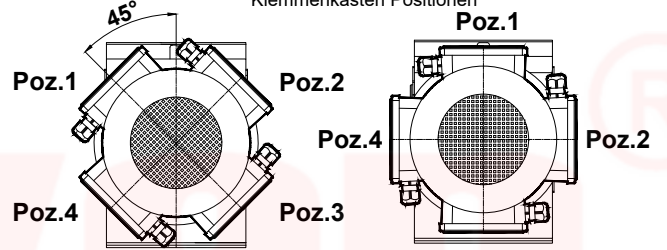

80-90  
Tip / Type / Typ

Poz.3  
71-100-112-132  
Tip / Type / Typ

KR875.03  
KR876.03

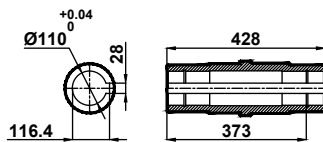
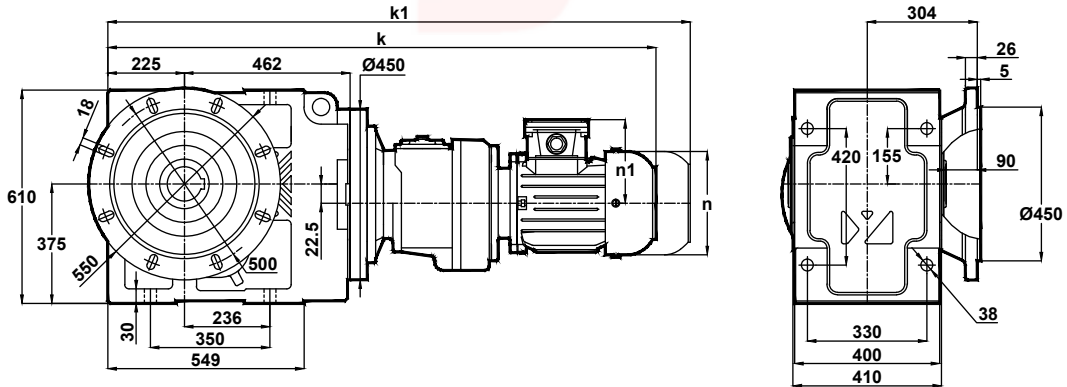

	71	80	90S	90L	100L	112M	132S	132M
k	1133	1161	1190	1215	1255	1278	1332	1370
k1	1255	1281	1315	1340	1390	1413	1477	1515
n	138	156	176	176	194	218	258	258
n1	110	118	126	126	135	146	168	168



# Ölçü Sayfaları Dimension Pages Abmessungenseiten



-Mil ucu çekirme deliği DIN 332 sayfa 2 / Tapped center hole to DIN 332, sheet 2 / Zentrierung mit gewinde DIN 332, Blatt 2

KR875.04  
KR876.04

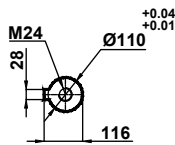
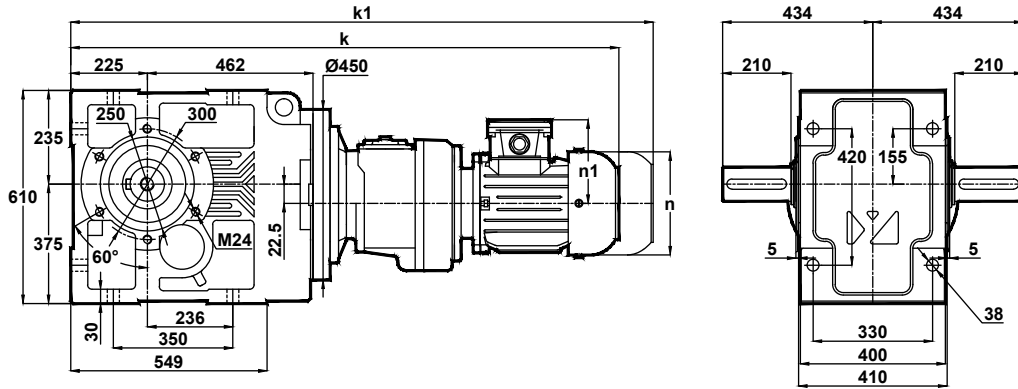

	71	80	90S	90L	100L	112M	132S	132M
k	1133	1161	1190	1215	1255	1278	1332	1370
k1	1255	1281	1315	1340	1390	1413	1477	1515
n	138	156	176	176	194	218	258	258
n1	110	118	126	126	135	146	168	168

Klemens Pozisyonları  
Terminal Box Positions  
Klemmenkasten Positionen

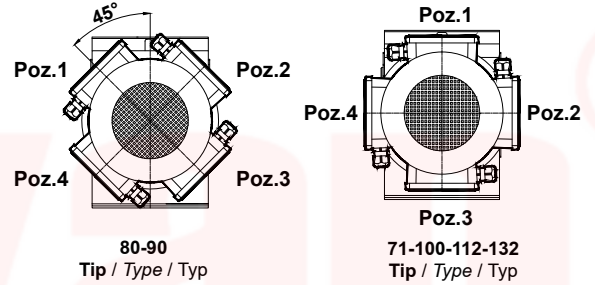

KR875.05  
KR876.05

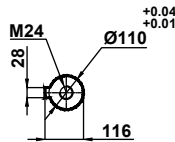
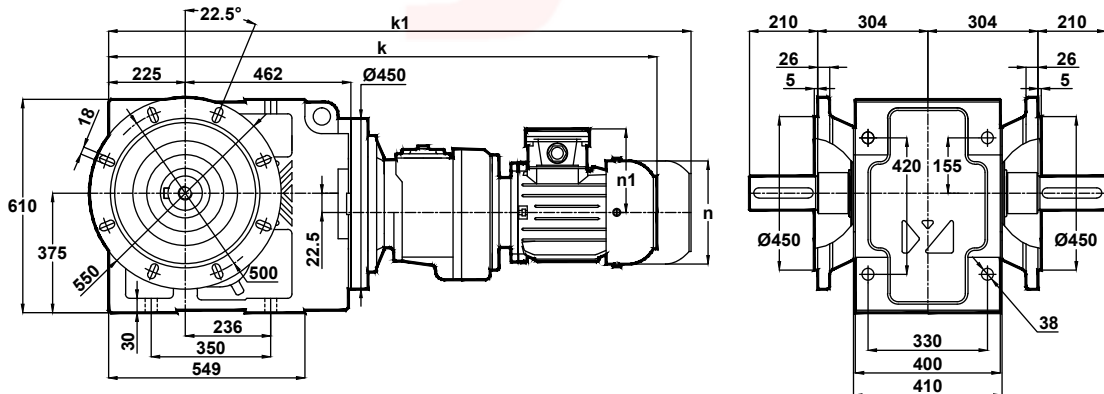

	71	80	90S	90L	100L	112M	132S	132M
k	1133	1161	1190	1215	1255	1278	1332	1370
k1	1255	1281	1315	1340	1390	1413	1477	1515
n	138	156	176	176	194	218	258	258
n1	110	118	126	126	135	146	168	168



# Ölçü Sayfaları Dimension Pages Abmessungsseiten



-Mil ucu çektirme deliği DIN 332 sayfa 2 / Tapped center hole to DIN 332, sheet 2 / Zentrierung mit gewinde DIN 332, Blatt 2

KR875.08  
KR876.08

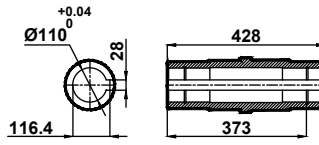
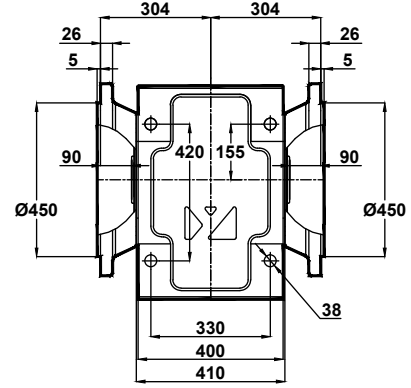
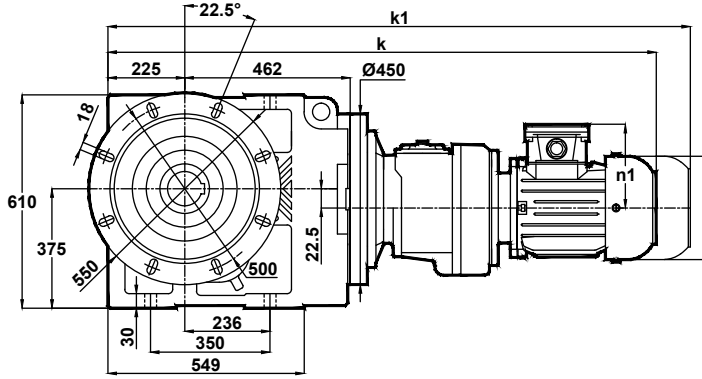

Klemens Pozisyonları  
Terminal Box Positions  
Klemmenkasten Positionen

	71	80	90S	90L	100L	112M	132S	132M
k	1133	1161	1190	1215	1255	1278	1332	1370
k1	1255	1281	1315	1340	1390	1413	1477	1515
n	138	156	176	176	194	218	258	258
n1	110	118	126	126	135	146	168	168

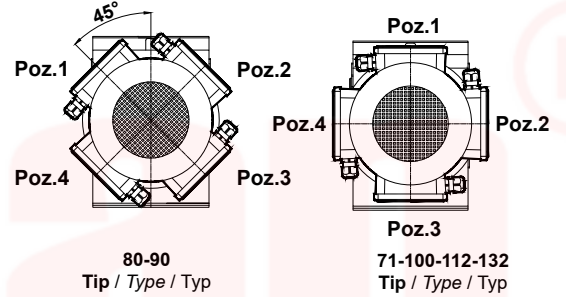



# Ölçü Sayfaları Dimension Pages Abmessungenseiten



-Mil ucu çekirme deliği DIN 332 sayfa 2 / Tapped center hole to DIN 332, sheet 2 / Zentrierung mit gewinde DIN 332, Blatt 2

## KN273.00

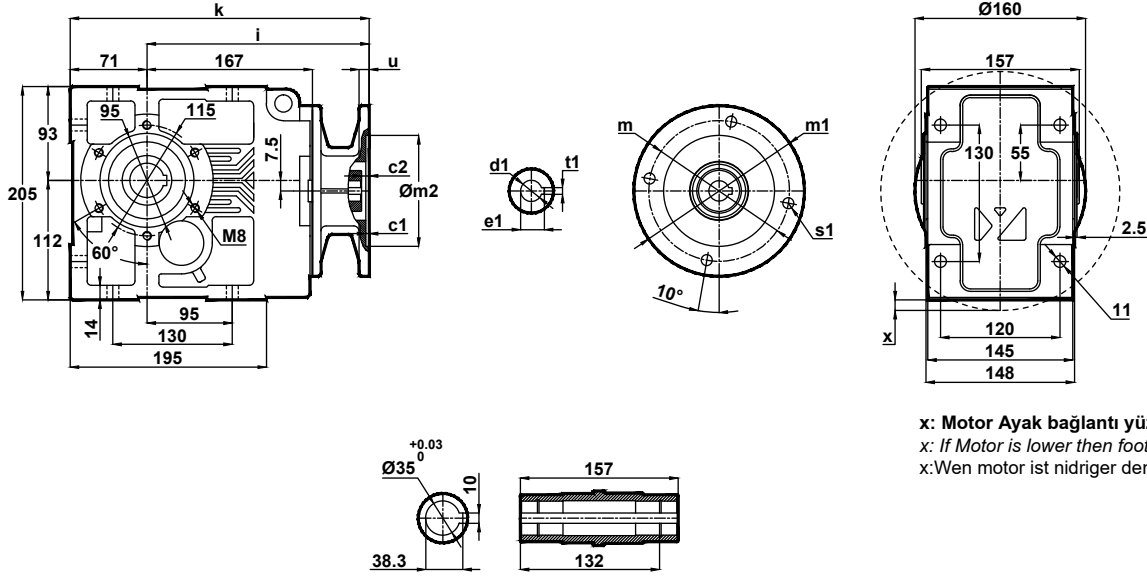

x: Motor Ayak bağlantı yüzeyinin altında ise  
x: If Motor is lower then foot mounting plane  
x: Wenn motor ist niedriger den die Anschlußplatte

	c1	c2	s1	m	m1	m2	i1	u	k	d1	t1	e1	x
63/B5	4	8	9	115	140	95	74	12	356	11	4	12.8	-
71/B5	4	8.5	11	130	160	110	45	12	327	14	5	16.3	-
80/B5	4	5	13	165	200	130	74	12	356	19	6	21.8	-
90/B5	4	5	13	165	200	130	74	12	356	24	8	27.3	-
100/B5	4	5.5	15	215	250	180	67	12	349	28	8	31.3	20.5
112/B5	4	5.5	15	215	250	180	67	12	349	28	8	31.3	20.5

## KN273.01

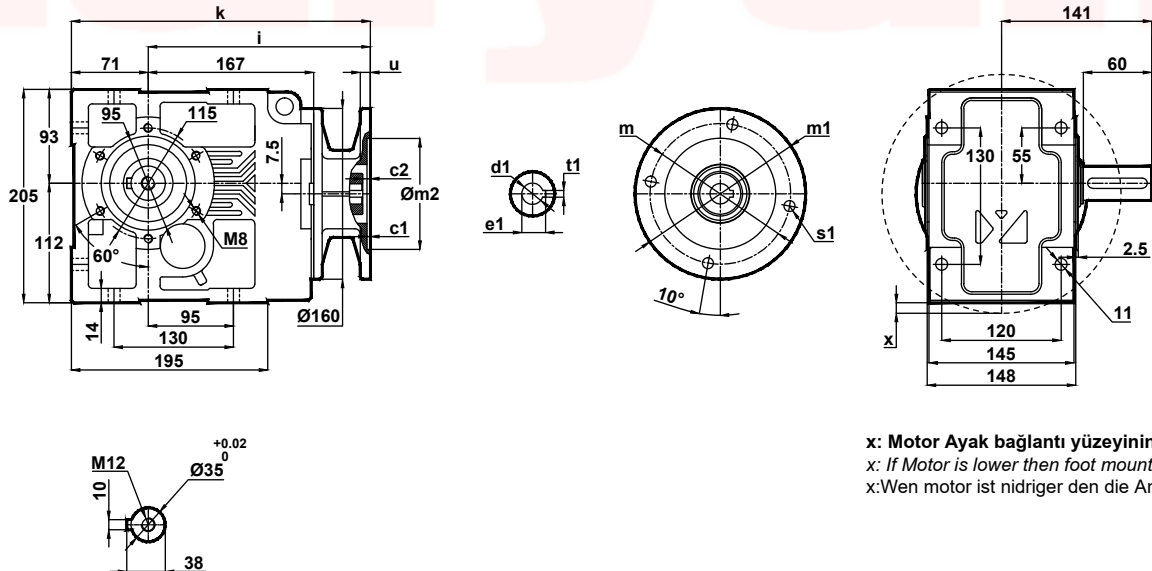

x: Motor Ayak bağlantı yüzeyinin altında ise  
x: If Motor is lower then foot mounting plane  
x: Wenn motor ist niedriger den die Anschlußplatte

	c1	c2	s1	m	m1	m2	i1	u	k	d1	t1	e1	x
63/B5	4	8	9	115	140	95	74	12	356	11	4	12.8	-
71/B5	4	8.5	11	130	160	110	45	12	327	14	5	16.3	-
80/B5	4	5	13	165	200	130	74	12	356	19	6	21.8	-
90/B5	4	5	13	165	200	130	74	12	356	24	8	27.3	-
100/B5	4	5.5	15	215	250	180	67	12	349	28	8	31.3	20.5
112/B5	4	5.5	15	215	250	180	67	12	349	28	8	31.3	20.5





# Ölçü Sayfaları Dimension Pages Abmessungsseiten



-Mil ucu çektirme deliği DIN 332 sayfa 2 / Tapped center hole to DIN 332, sheet 2 / Zentrierung mit gewinde DIN 332, Blatt 2

## KN273.02

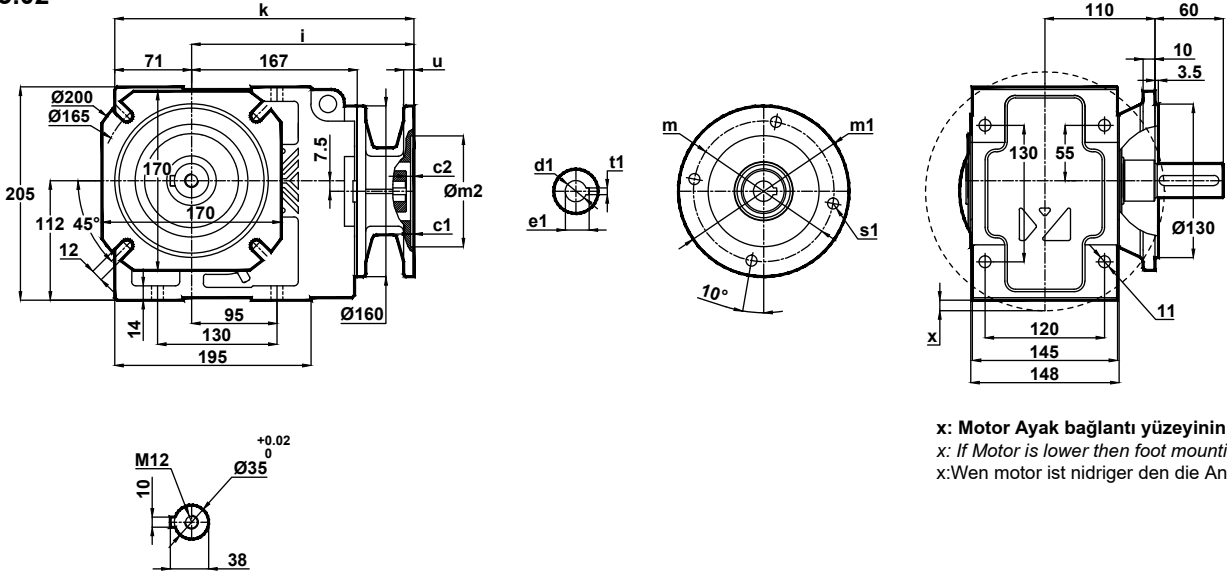

x: Motor Ayak bağlantı yüzeyinin altında ise  
x: If Motor is lower then foot mounting plane  
x: Wenn motor ist niedriger den die Anschlußplatte

	c1	c2	s1	m	m1	m2	i1	u	k	d1	t1	e1	x
63/B5	4	8	9	115	140	95	74	12	356	11	4	12.8	-
71/B5	4	8.5	11	130	160	110	45	12	327	14	5	16.3	-
80/B5	4	5	13	165	200	130	74	12	356	19	6	21.8	-
90/B5	4	5	13	165	200	130	74	12	356	24	8	27.3	-
100/B5	4	5.5	15	215	250	180	67	12	349	28	8	31.3	20.5
112/B5	4	5.5	15	215	250	180	67	12	349	28	8	31.3	20.5

## KN273.03

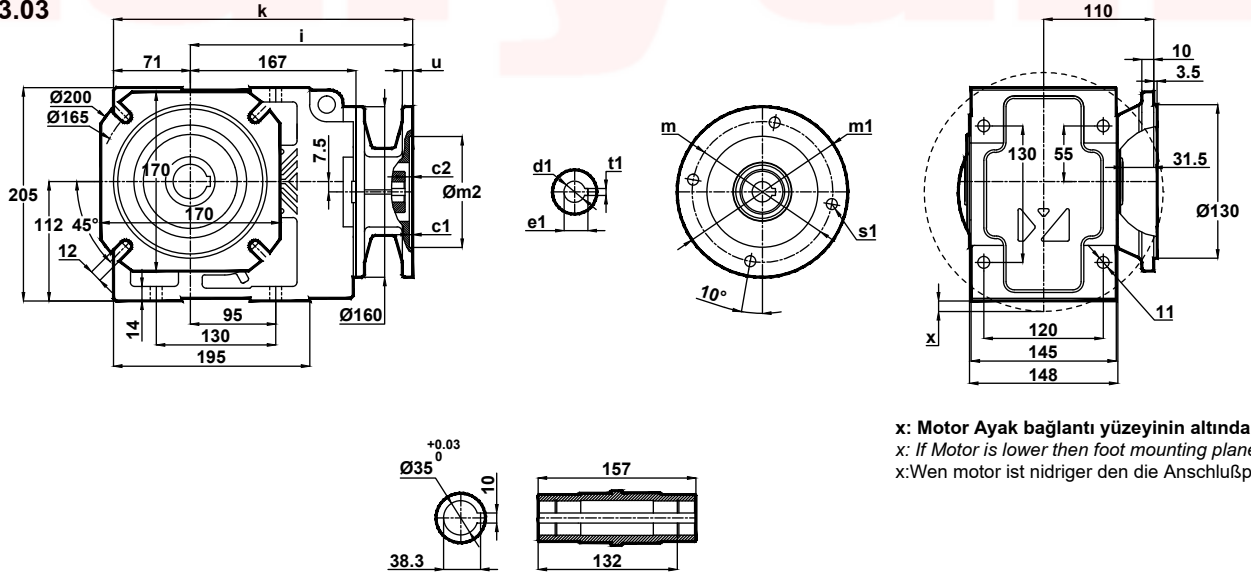

x: Motor Ayak bağlantı yüzeyinin altında ise  
x: If Motor is lower then foot mounting plane  
x: Wenn motor ist niedriger den die Anschlußplatte

	c1	c2	s1	m	m1	m2	i1	u	k	d1	t1	e1	x
63/B5	4	8	9	115	140	95	74	12	356	11	4	12.8	-
71/B5	4	8.5	11	130	160	110	45	12	327	14	5	16.3	-
80/B5	4	5	13	165	200	130	74	12	356	19	6	21.8	-
90/B5	4	5	13	165	200	130	74	12	356	24	8	27.3	-
100/B5	4	5.5	15	215	250	180	67	12	349	28	8	31.3	20.5
112/B5	4	5.5	15	215	250	180	67	12	349	28	8	31.3	20.5



# Ölçü Sayfaları

## Dimension Pages

### Abmessungsseiten



-Mil ucu çekirme deliği DIN 332 sayfa 2 / Tapped center hole to DIN 332, sheet 2 / Zentrierung mit gewinde DIN 332, Blatt 2

#### KN273.04

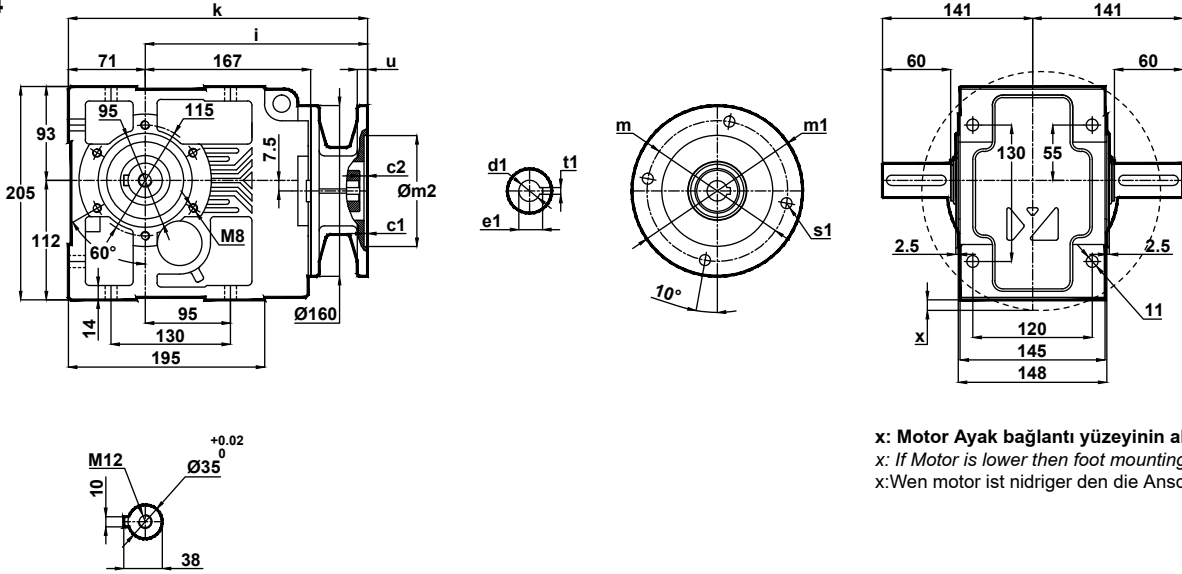

**x: Motor Ayak bağlantı yüzeyinin altında ise**  
*x: If Motor is lower then foot mounting plane*  
*x: Wenn motor ist niedriger den die Anschlußplatte*

	c1	c2	s1	m	m1	m2	i1	u	k	d1	t1	e1	x
63/B5	4	8	9	115	140	95	74	12	356	11	4	12.8	-
71/B5	4	8.5	11	130	160	110	45	12	327	14	5	16.3	-
80/B5	4	5	13	165	200	130	74	12	356	19	6	21.8	-
90/B5	4	5	13	165	200	130	74	12	356	24	8	27.3	-
100/B5	4	5.5	15	215	250	180	67	12	349	28	8	31.3	20.5
112/B5	4	5.5	15	215	250	180	67	12	349	28	8	31.3	20.5

#### KN273.05

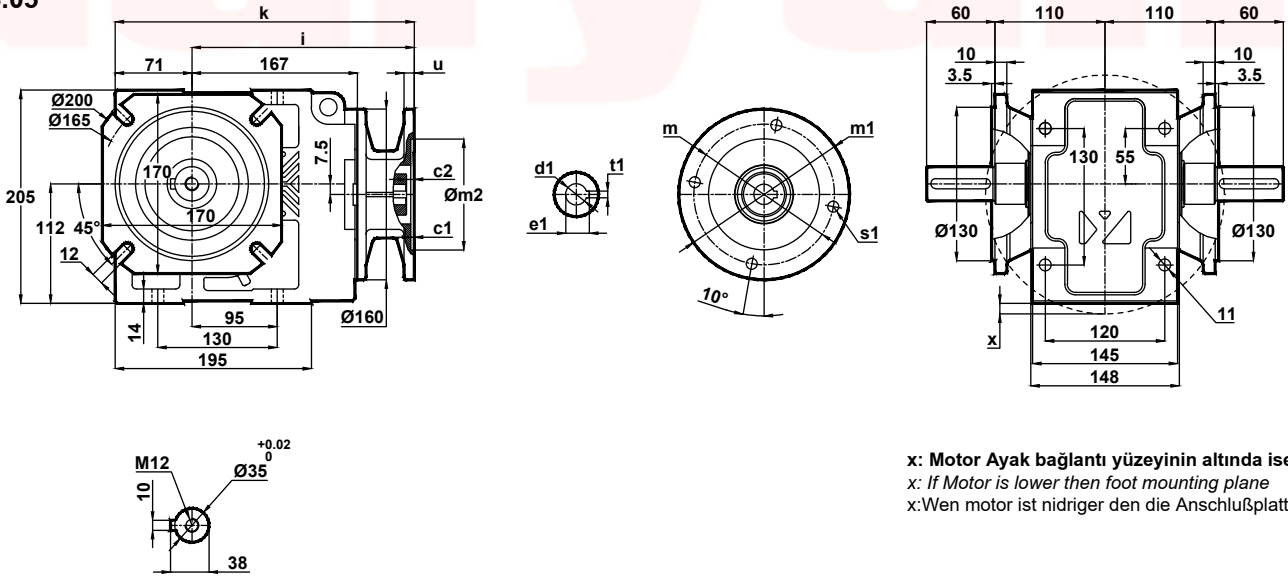

**x: Motor Ayak bağlantı yüzeyinin altında ise**  
*x: If Motor is lower then foot mounting plane*  
*x: Wenn motor ist niedriger den die Anschlußplatte*

	c1	c2	s1	m	m1	m2	i1	u	k	d1	t1	e1	x
63/B5	4	8	9	115	140	95	74	12	356	11	4	12.8	-
71/B5	4	8.5	11	130	160	110	45	12	327	14	5	16.3	-
80/B5	4	5	13	165	200	130	74	12	356	19	6	21.8	-
90/B5	4	5	13	165	200	130	74	12	356	24	8	27.3	-
100/B5	4	5.5	15	215	250	180	67	12	349	28	8	31.3	20.5
112/B5	4	5.5	15	215	250	180	67	12	349	28	8	31.3	20.5



# Ölçü Sayfaları Dimension Pages Abmessungsseiten



-Mil ucu çekirme deliği DIN 332 sayfa 2 / Tapped center hole to DIN 332, sheet 2 / Zentrierung mit gewinde DIN 332, Blatt 2

KN273.08

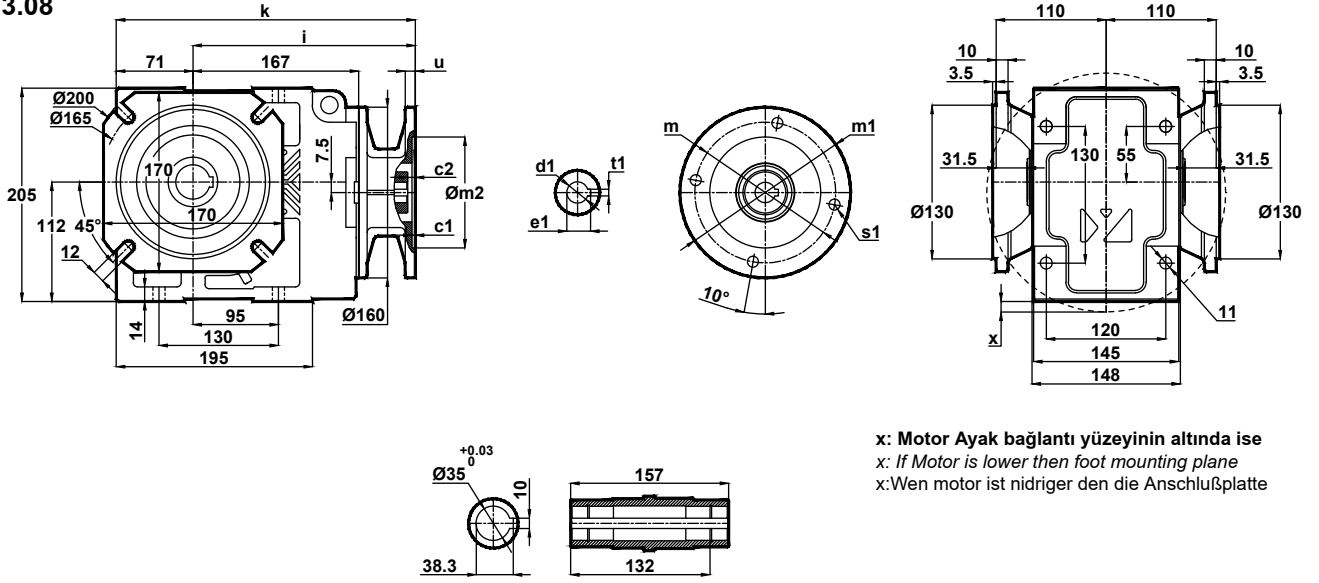

x: Motor Ayak bağlantı yüzeyinin altında ise  
x: If Motor is lower then foot mounting plane  
x: Wenn motor ist niedriger den die Anschlußplatte

	c1	c2	s1	m	m1	m2	i1	u	k	d1	t1	e1	x
63/B5	4	8	9	115	140	95	74	12	356	11	4	12.8	-
71/B5	4	8.5	11	130	160	110	45	12	327	14	5	16.3	-
80/B5	4	5	13	165	200	130	74	12	356	19	6	21.8	-
90/B5	4	5	13	165	200	130	74	12	356	24	8	27.3	-
100/B5	4	5.5	15	215	250	180	67	12	349	28	8	31.3	20.5
112/B5	4	5.5	15	215	250	180	67	12	349	28	8	31.3	20.5



# Ölçü Sayfaları

## Dimension Pages

### Abmessungsseiten



-Mil ucu çekirme deliği DIN 332 sayfa 2 / Tapped center hole to DIN 332, sheet 2 / Zentrierung mit gewinde DIN 332, Blatt 2

KN275.00  
KN276.00

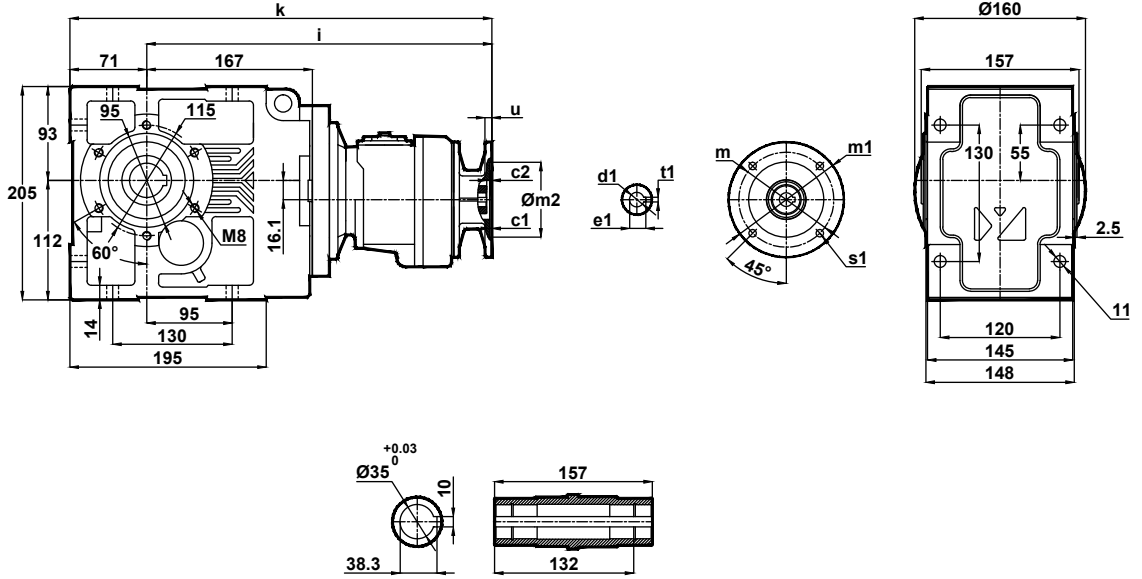

	c1	c2	s1	m	m1	m2	i1	u	k	d1	t1	e1
63/B5	3.5	5	10	115	140	95	356	10	427	11	4	12.8
71/B5	4	4.5	11	130	160	110	358	12	429	14	5	16.3
80/B5	4	5	13	165	200	130	373	12	444	19	6	21.8
90/B5	4	5	13	165	200	130	373	12	444	24	8	27.3

KN275.01  
KN276.01

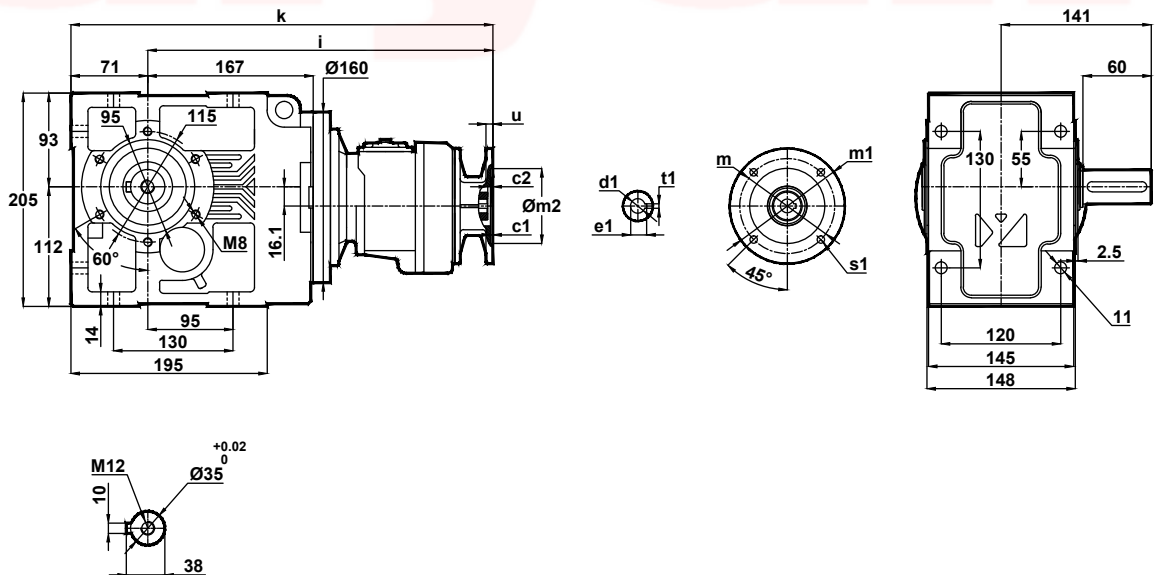

	c1	c2	s1	m	m1	m2	i1	u	k	d1	t1	e1
63/B5	3.5	5	10	115	140	95	356	10	427	11	4	12.8
71/B5	4	4.5	11	130	160	110	358	12	429	14	5	16.3
80/B5	4	5	13	165	200	130	373	12	444	19	6	21.8
90/B5	4	5	13	165	200	130	373	12	444	24	8	27.3



# Ölçü Sayfaları Dimension Pages Abmessungsseiten



-Mil ucu çekirme deliği DIN 332 sayfa 2 / Tapped center hole to DIN 332, sheet 2 / Zentrierung mit gewinde DIN 332, Blatt 2

KN275.02  
KN276.02

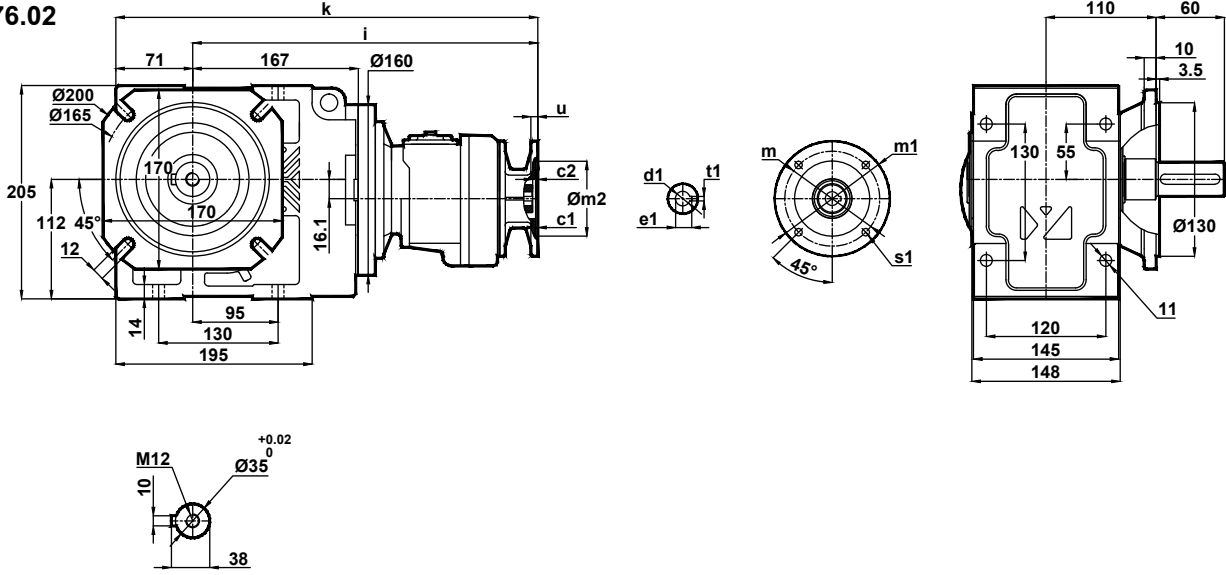

	c1	c2	s1	m	m1	m2	i1	u	k	d1	t1	e1
63/B5	3.5	5	10	115	140	95	356	10	427	11	4	12.8
71/B5	4	4.5	11	130	160	110	358	12	429	14	5	16.3
80/B5	4	5	13	165	200	130	373	12	444	19	6	21.8
90/B5	4	5	13	165	200	130	373	12	444	24	8	27.3

KN275.03  
KN276.03

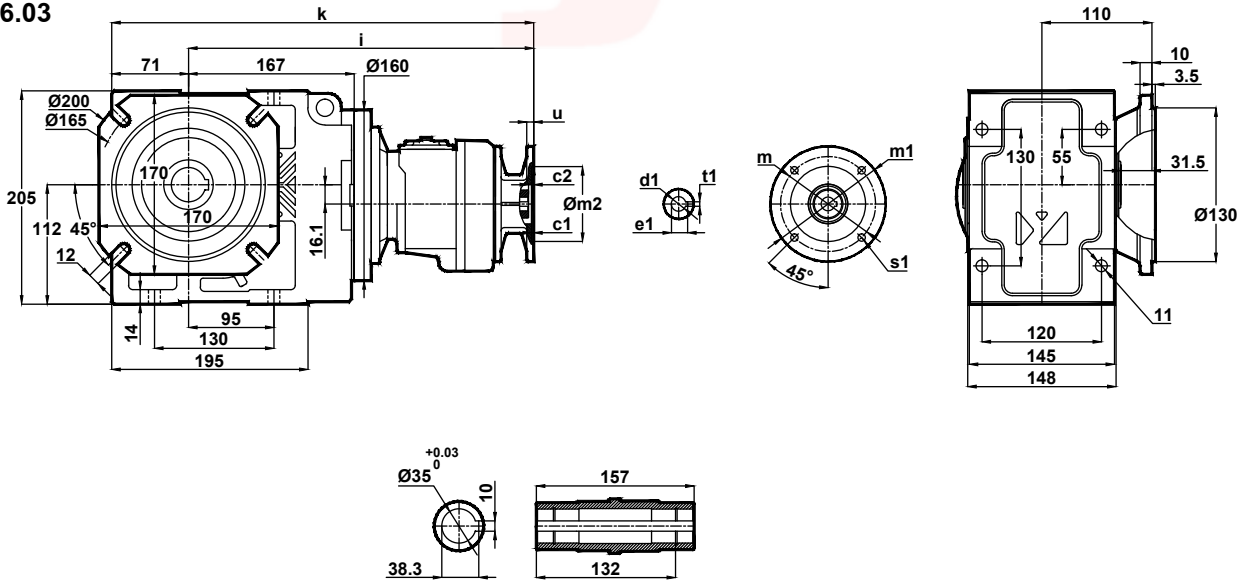

	c1	c2	s1	m	m1	m2	i1	u	k	d1	t1	e1
63/B5	3.5	5	10	115	140	95	356	10	427	11	4	12.8
71/B5	4	4.5	11	130	160	110	358	12	429	14	5	16.3
80/B5	4	5	13	165	200	130	373	12	444	19	6	21.8
90/B5	4	5	13	165	200	130	373	12	444	24	8	27.3



# Ölçü Sayfaları

## Dimension Pages

## Abmessungsseiten



-Mil ucu çektirme deliği DIN 332 sayfa 2 / Tapped center hole to DIN 332, sheet 2 / Zentrierung mit gewinde DIN 332, Blatt 2

KN275.04  
KN276.04

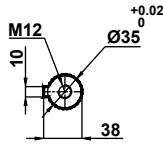
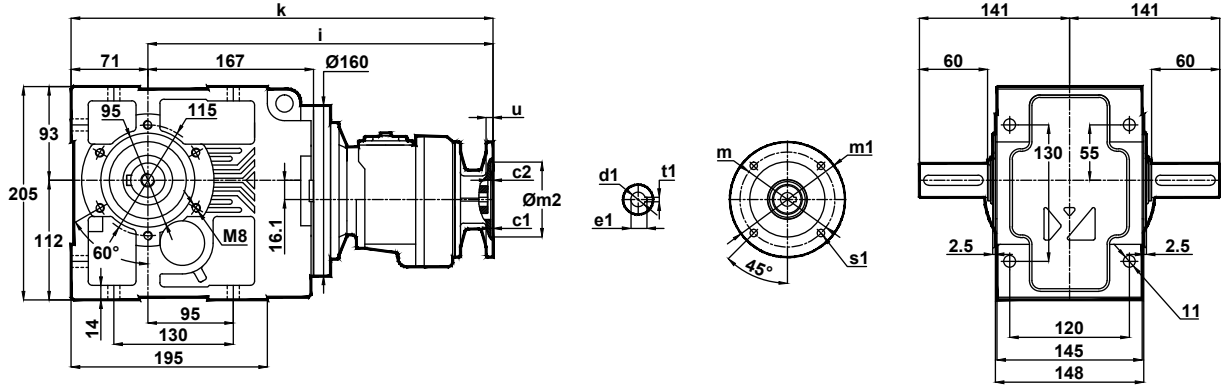

	c1	c2	s1	m	m1	m2	i1	u	k	d1	t1	e1
63/B5	3.5	5	10	115	140	95	356	10	427	11	4	12.8
71/B5	4	4.5	11	130	160	110	358	12	429	14	5	16.3
80/B5	4	5	13	165	200	130	373	12	444	19	6	21.8
90/B5	4	5	13	165	200	130	373	12	444	24	8	27.3

KN275.05  
KN276.05

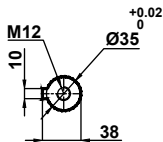
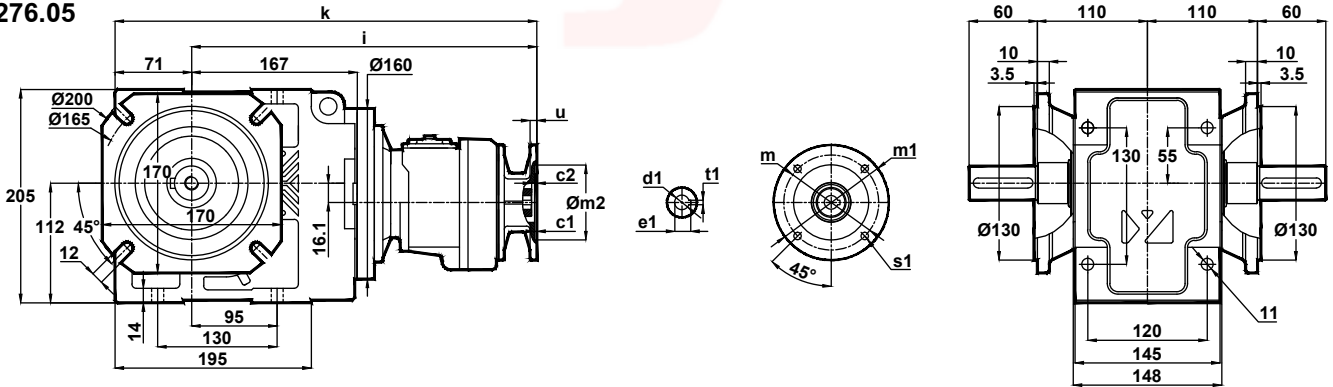

	c1	c2	s1	m	m1	m2	i1	u	k	d1	t1	e1
63/B5	3.5	5	10	115	140	95	356	10	427	11	4	12.8
71/B5	4	4.5	11	130	160	110	358	12	429	14	5	16.3
80/B5	4	5	13	165	200	130	373	12	444	19	6	21.8
90/B5	4	5	13	165	200	130	373	12	444	24	8	27.3



# Ölçü Sayfaları Dimension Pages Abmessungenseiten



-Mil ucu çekirtme deliği DIN 332 sayfa 2 / Tapped center hole to DIN 332, sheet 2 / Zentrierung mit gewinde DIN 332, Blatt 2

KN275.08  
KN276.08

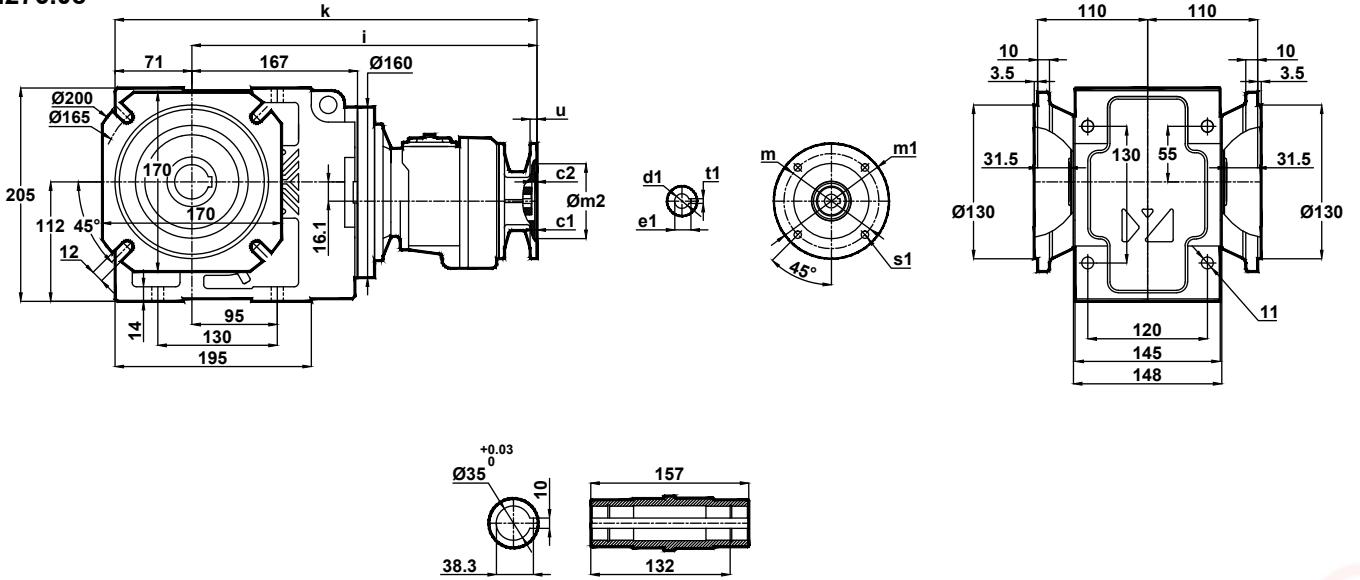

	c1	c2	s1	m	m1	m2	i1	u	k	d1	t1	e1
63/B5	3.5	5	10	115	140	95	356	10	427	11	4	12.8
71/B5	4	4.5	11	130	160	110	358	12	429	14	5	16.3
80/B5	4	5	13	165	200	130	373	12	444	19	6	21.8
90/B5	4	5	13	165	200	130	373	12	444	24	8	27.3



# Ölçü Sayfaları Dimension Pages Abmessungsseiten



-Mil ucu çektirme deliği DIN 332 sayfa 2 / Tapped center hole to DIN 332, sheet 2 / Zentrierung mit gewinde DIN 332, Blatt 2

## KN373.00

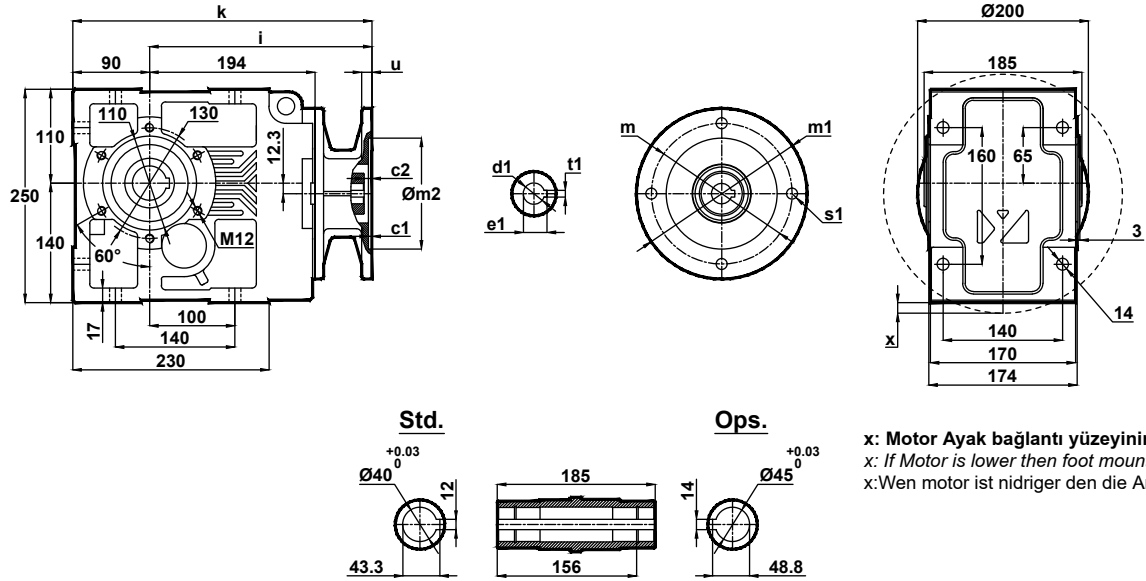

	c1	c2	s1	m	m1	m2	i1	u	k	d1	t1	e1	x
71/B5	4	9	11	130	160	110	67	12	417	14	5	16.3	-
80/B5	4	9	13	165	200	130	67	12	417	19	6	21.8	-
90/B5	4	9	13	165	200	130	67	12	417	24	8	27.3	-
100/B5	4.5	9	15	215	250	180	84	15	434	28	8	31.3	-
112/B5	4.5	9	15	215	250	180	84	15	434	28	8	31.3	-
132/B5	4.5	7	15	265	300	230	104	15	454	38	10	41.3	22.3

## KN373.01

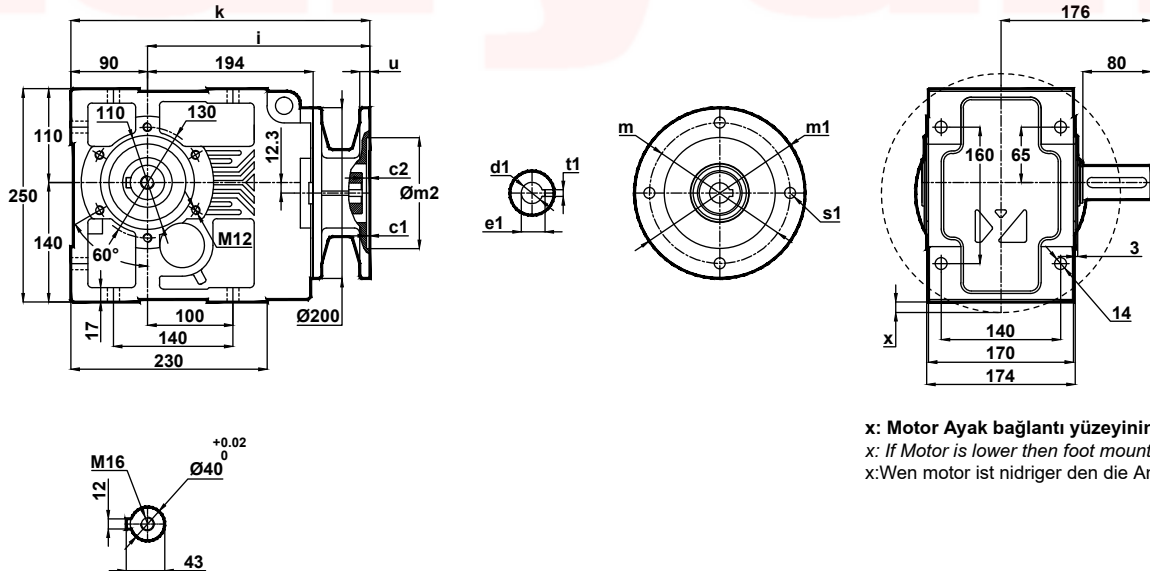

	c1	c2	s1	m	m1	m2	i1	u	k	d1	t1	e1	x
71/B5	4	9	11	130	160	110	67	12	417	14	5	16.3	-
80/B5	4	9	13	165	200	130	67	12	417	19	6	21.8	-
90/B5	4	9	13	165	200	130	67	12	417	24	8	27.3	-
100/B5	4.5	9	15	215	250	180	84	15	434	28	8	31.3	-
112/B5	4.5	9	15	215	250	180	84	15	434	28	8	31.3	-
132/B5	4.5	7	15	265	300	230	104	15	454	38	10	41.3	22.3





# Ölçü Sayfaları Dimension Pages Abmessungsseiten



-Mil ucu çektirme deliği DIN 332 sayfa 2 / Tapped center hole to DIN 332, sheet 2 / Zentrierung mit gewinde DIN 332, Blatt 2

## KN373.02

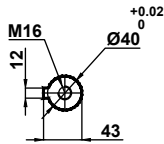
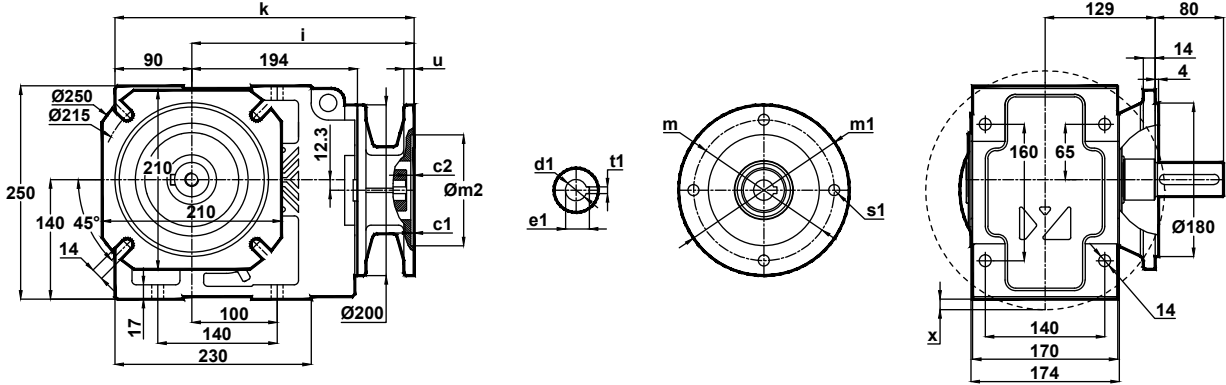

x: Motor Ayak bağlantı yüzeyinin altında ise  
x: If Motor is lower then foot mounting plane  
x:Wen motor ist nidriger den die Anschlußplatte

	c1	c2	s1	m	m1	m2	i1	u	k	d1	t1	e1	x
71/B5	4	9	11	130	160	110	67	12	417	14	5	16.3	-
80/B5	4	9	13	165	200	130	67	12	417	19	6	21.8	-
90/B5	4	9	13	165	200	130	67	12	417	24	8	27.3	-
100/B5	4.5	9	15	215	250	180	84	15	434	28	8	31.3	-
112/B5	4.5	9	15	215	250	180	84	15	434	28	8	31.3	-
132/B5	4.5	7	15	265	300	230	104	15	454	38	10	41.3	22.3

## KN373.03

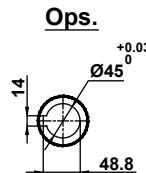
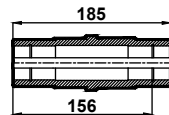
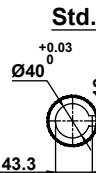
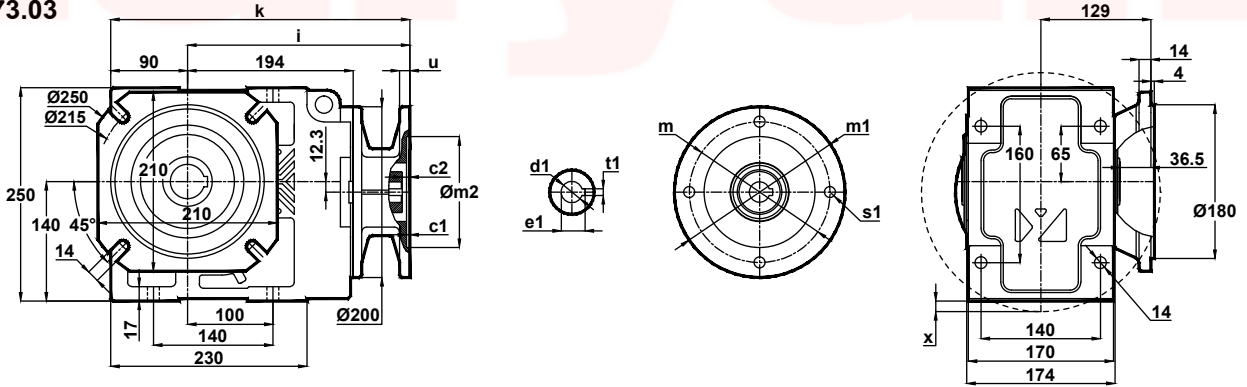

x: Motor Ayak bağlantı yüzeyinin altında ise  
x: If Motor is lower then foot mounting plane  
x:Wen motor ist nidriger den die Anschlußplatte

	c1	c2	s1	m	m1	m2	i1	u	k	d1	t1	e1	x
71/B5	4	9	11	130	160	110	67	12	417	14	5	16.3	-
80/B5	4	9	13	165	200	130	67	12	417	19	6	21.8	-
90/B5	4	9	13	165	200	130	67	12	417	24	8	27.3	-
100/B5	4.5	9	15	215	250	180	84	15	434	28	8	31.3	-
112/B5	4.5	9	15	215	250	180	84	15	434	28	8	31.3	-
132/B5	4.5	7	15	265	300	230	104	15	454	38	10	41.3	22.3



# Ölçü Sayfaları Dimension Pages Abmessungsseiten



-Mil ucu çektirme deliği DIN 332 sayfa 2 / Tapped center hole to DIN 332, sheet 2 / Zentrierung mit gewinde DIN 332, Blatt 2

## KN373.04

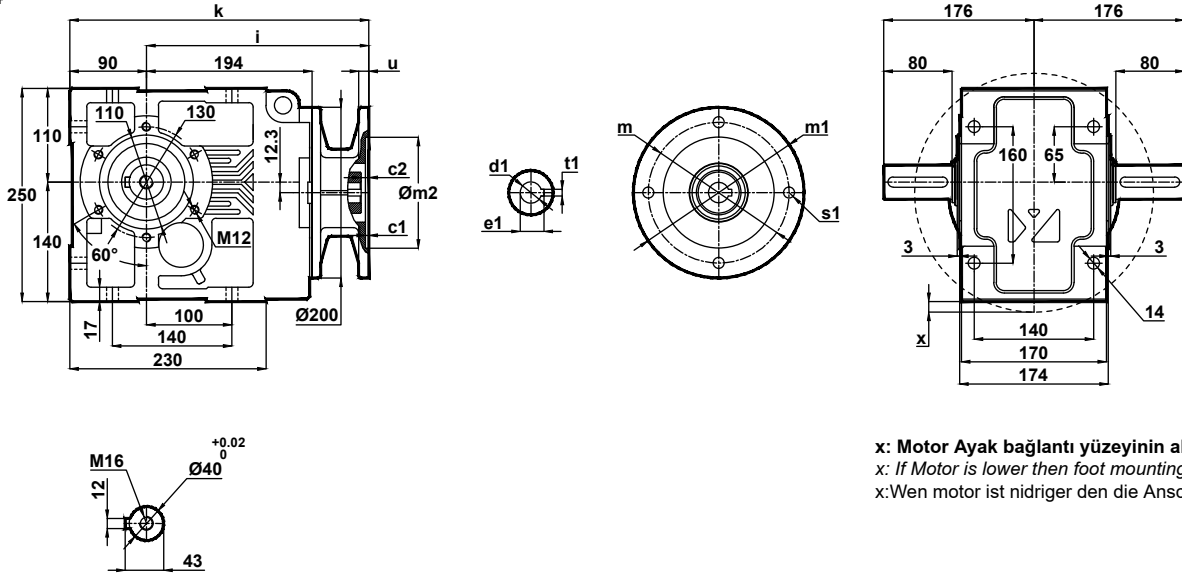

x: Motor ayak bağlantı yüzeyinin altında ise  
x: If Motor is lower then foot mounting plane  
x: Wenn motor ist niedriger den die Anschlußplatte

	c1	c2	s1	m	m1	m2	i1	u	k	d1	t1	e1	x
71/B5	4	9	11	130	160	110	67	12	417	14	5	16.3	-
80/B5	4	9	13	165	200	130	67	12	417	19	6	21.8	-
90/B5	4	9	13	165	200	130	67	12	417	24	8	27.3	-
100/B5	4.5	9	15	215	250	180	84	15	434	28	8	31.3	-
112/B5	4.5	9	15	215	250	180	84	15	434	28	8	31.3	-
132/B5	4.5	7	15	265	300	230	104	15	454	38	10	41.3	22.3

## KN373.05

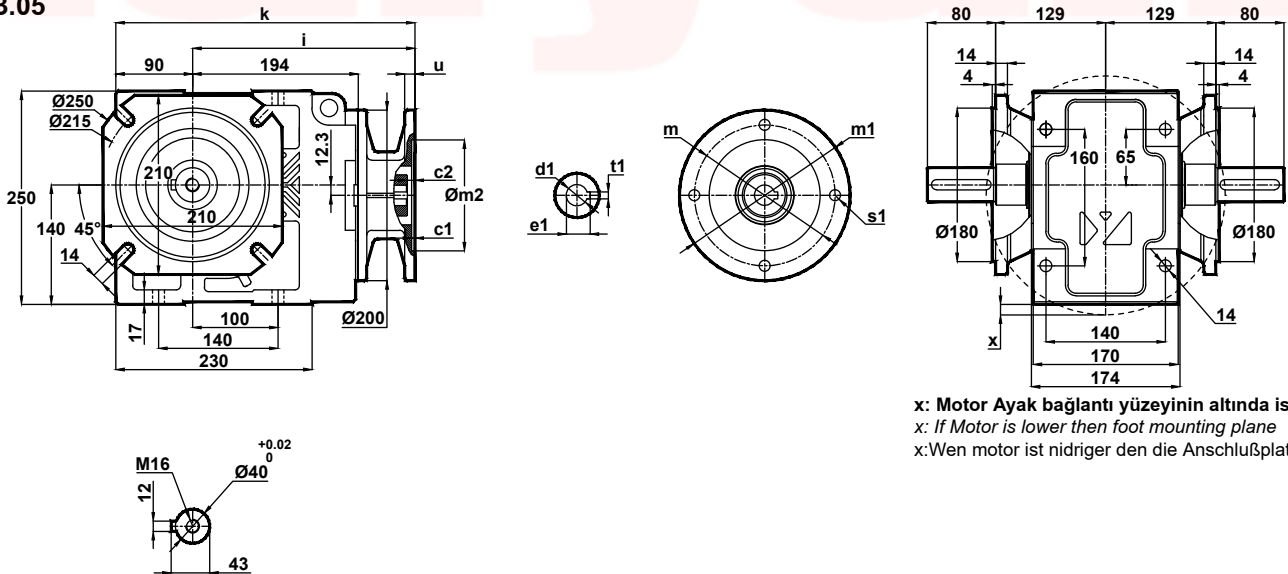

x: Motor ayak bağlantı yüzeyinin altında ise  
x: If Motor is lower then foot mounting plane  
x: Wenn motor ist niedriger den die Anschlußplatte

	c1	c2	s1	m	m1	m2	i1	u	k	d1	t1	e1	x
71/B5	4	9	11	130	160	110	67	12	417	14	5	16.3	-
80/B5	4	9	13	165	200	130	67	12	417	19	6	21.8	-
90/B5	4	9	13	165	200	130	67	12	417	24	8	27.3	-
100/B5	4.5	9	15	215	250	180	84	15	434	28	8	31.3	-
112/B5	4.5	9	15	215	250	180	84	15	434	28	8	31.3	-
132/B5	4.5	7	15	265	300	230	104	15	454	38	10	41.3	22.3



# Ölçü Sayfaları Dimension Pages Abmessungsseiten



-Mil ucu çektirme deliği DIN 332 sayfa 2 / Tapped center hole to DIN 332, sheet 2 / Zentrierung mit gewinde DIN 332, Blatt 2

KN373.08

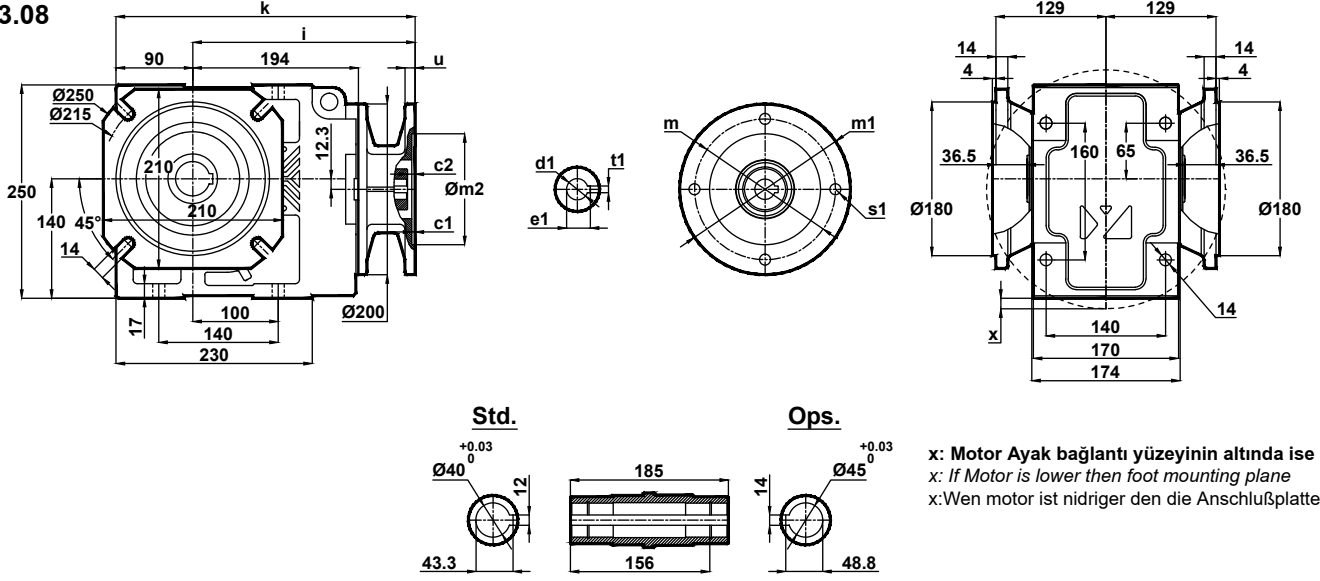

	c1	c2	s1	m	m1	m2	i1	u	k	d1	t1	e1	x
71/B5	4	9	11	130	160	110	67	12	417	14	5	16.3	-
80/B5	4	9	13	165	200	130	67	12	417	19	6	21.8	-
90/B5	4	9	13	165	200	130	67	12	417	24	8	27.3	-
100/B5	4.5	9	15	215	250	180	84	15	434	28	8	31.3	-
112/B5	4.5	9	15	215	250	180	84	15	434	28	8	31.3	-
132/B5	4.5	7	15	265	300	230	104	15	454	38	10	41.3	22.3



# Ölçü Sayfaları

## Dimension Pages

### Abmessungsseiten



-Mil ucu çektirme deliği DIN 332 sayfa 2 / Tapped center hole to DIN 332, sheet 2 / Zentrierung mit gewinde DIN 332, Blatt 2

#### KN374.00

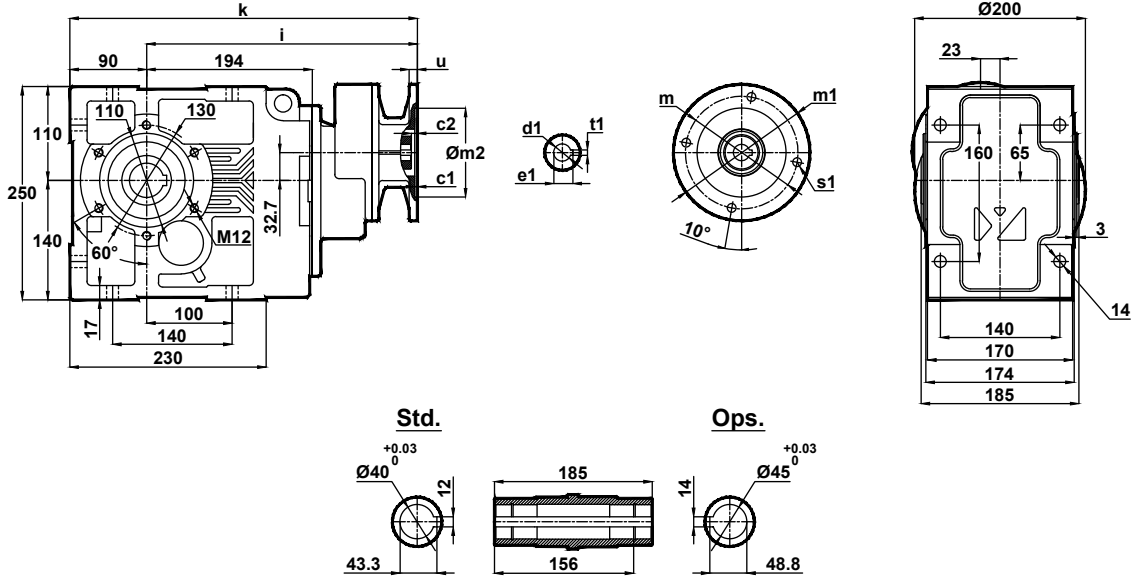

	c1	c2	s1	m	m1	m2	i1	u	k	d1	t1	e1
63/B5	4	8	9	115	140	95	338	12	356	11	4	12.8
71/B5	4	8.5	11	130	160	110	309	12	327	14	5	16.3
80/B5	4	5	13	165	200	130	338	12	356	19	6	21.8
90/B5	4	5	13	165	200	130	338	12	356	24	8	27.3
100/B5	4	5.5	15	215	250	180	331	12	349	28	8	31.3
112/B5	4	5.5	15	215	250	180	331	12	349	28	8	31.3

#### KN374.01

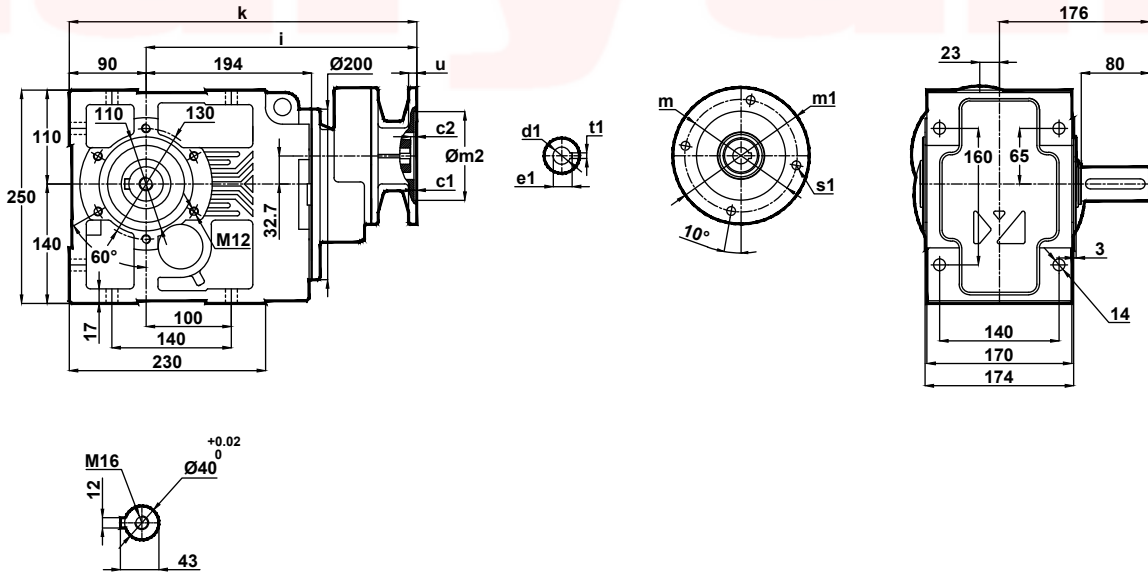

	c1	c2	s1	m	m1	m2	i1	u	k	d1	t1	e1
63/B5	4	8	9	115	140	95	338	12	356	11	4	12.8
71/B5	4	8.5	11	130	160	110	309	12	327	14	5	16.3
80/B5	4	5	13	165	200	130	338	12	356	19	6	21.8
90/B5	4	5	13	165	200	130	338	12	356	24	8	27.3
100/B5	4	5.5	15	215	250	180	331	12	349	28	8	31.3
112/B5	4	5.5	15	215	250	180	331	12	349	28	8	31.3



# Ölçü Sayfaları Dimension Pages Abmessungsseiten



-Mil ucu çekirme deliği DIN 332 sayfa 2 / Tapped center hole to DIN 332, sheet 2 / Zentrierung mit gewinde DIN 332, Blatt 2

## KN374.02

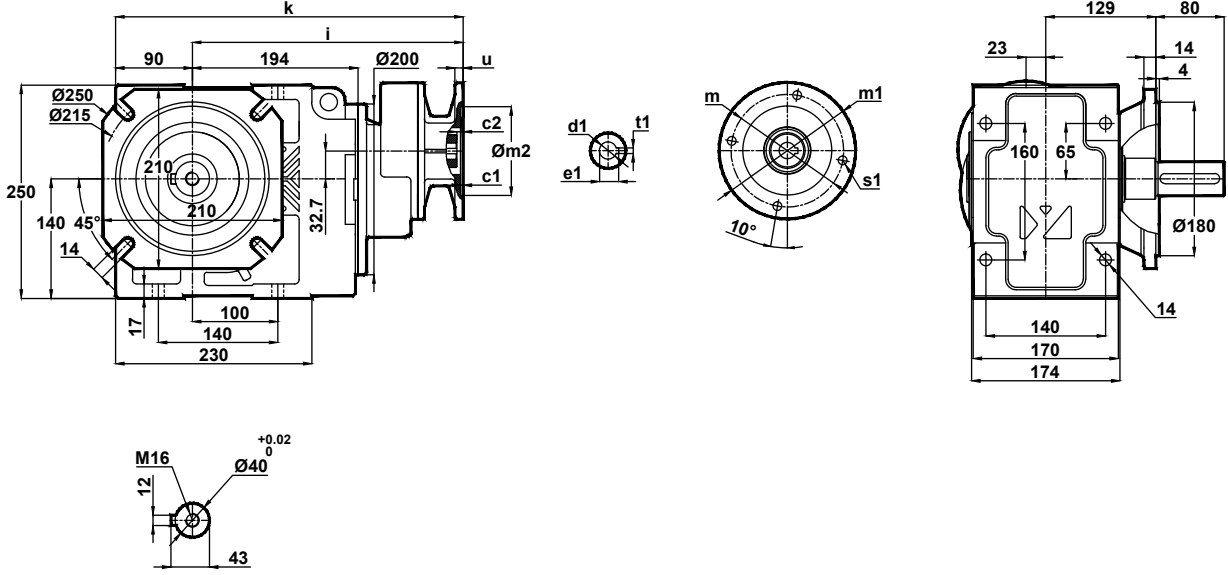

	c1	c2	s1	m	m1	m2	i1	u	k	d1	t1	e1
63/B5	4	8	9	115	140	95	338	12	356	11	4	12.8
71/B5	4	8.5	11	130	160	110	309	12	327	14	5	16.3
80/B5	4	5	13	165	200	130	338	12	356	19	6	21.8
90/B5	4	5	13	165	200	130	338	12	356	24	8	27.3
100/B5	4	5.5	15	215	250	180	331	12	349	28	8	31.3
112/B5	4	5.5	15	215	250	180	331	12	349	28	8	31.3

## KN374.03

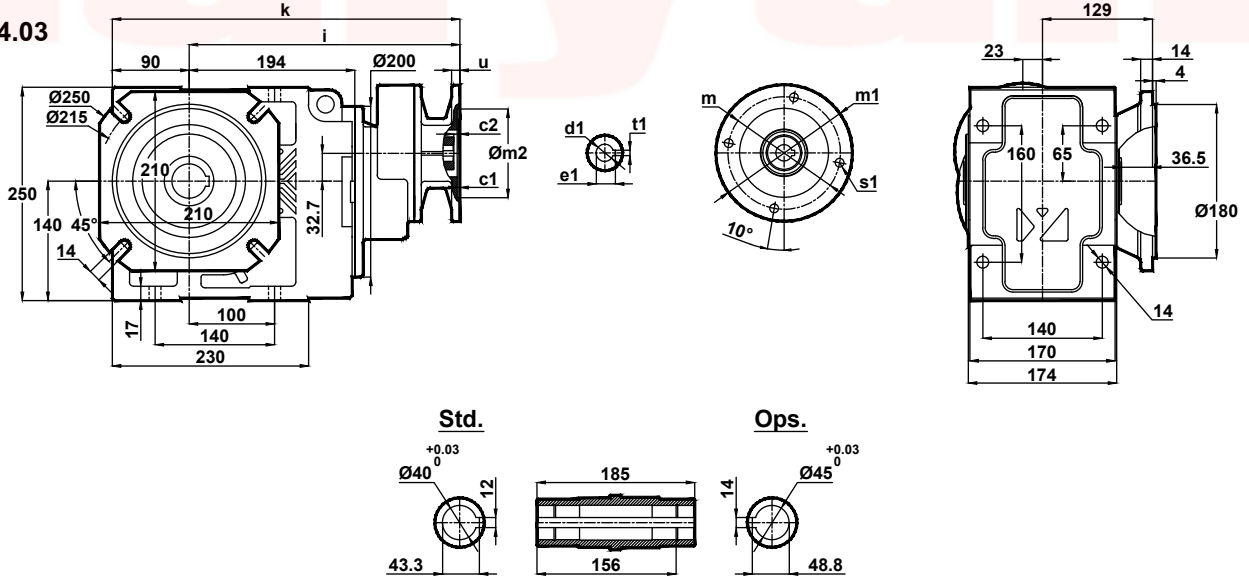

	c1	c2	s1	m	m1	m2	i1	u	k	d1	t1	e1
63/B5	4	8	9	115	140	95	338	12	356	11	4	12.8
71/B5	4	8.5	11	130	160	110	309	12	327	14	5	16.3
80/B5	4	5	13	165	200	130	338	12	356	19	6	21.8
90/B5	4	5	13	165	200	130	338	12	356	24	8	27.3
100/B5	4	5.5	15	215	250	180	331	12	349	28	8	31.3
112/B5	4	5.5	15	215	250	180	331	12	349	28	8	31.3



# Ölçü Sayfaları

## Dimension Pages

### Abmessungsseiten



-Mil ucu çektirme deliği DIN 332 sayfa 2 / Tapped center hole to DIN 332, sheet 2 / Zentrierung mit gewinde DIN 332, Blatt 2

#### KN374.04

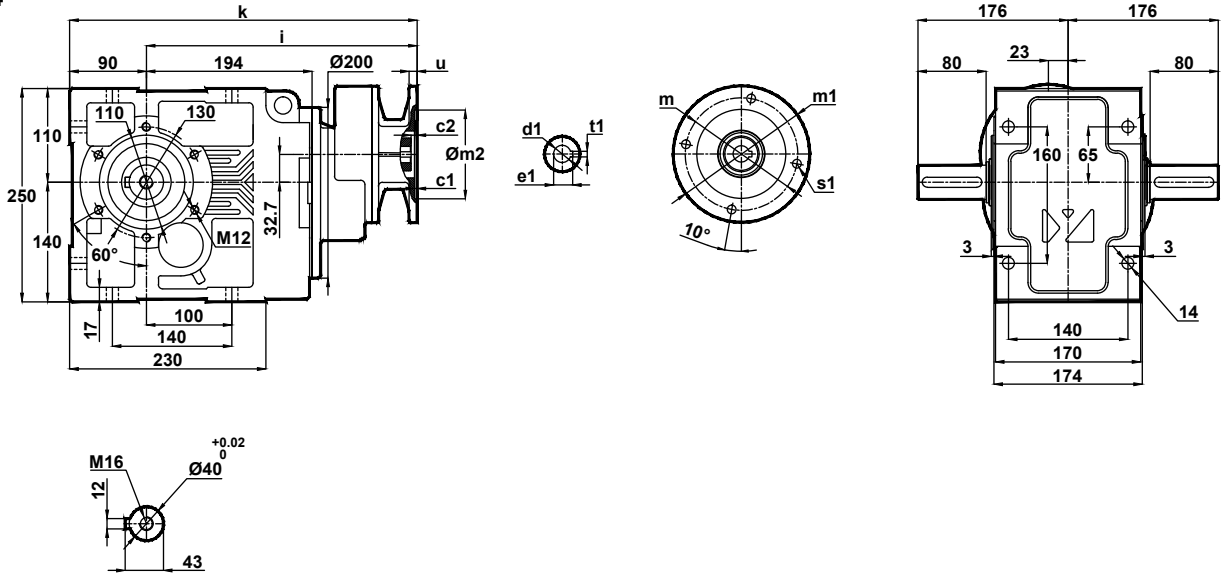

	c1	c2	s1	m	m1	m2	i1	u	k	d1	t1	e1
63/B5	4	8	9	115	140	95	338	12	356	11	4	12.8
71/B5	4	8.5	11	130	160	110	309	12	327	14	5	16.3
80/B5	4	5	13	165	200	130	338	12	356	19	6	21.8
90/B5	4	5	13	165	200	130	338	12	356	24	8	27.3
100/B5	4	5.5	15	215	250	180	331	12	349	28	8	31.3
112/B5	4	5.5	15	215	250	180	331	12	349	28	8	31.3

#### KN374.05

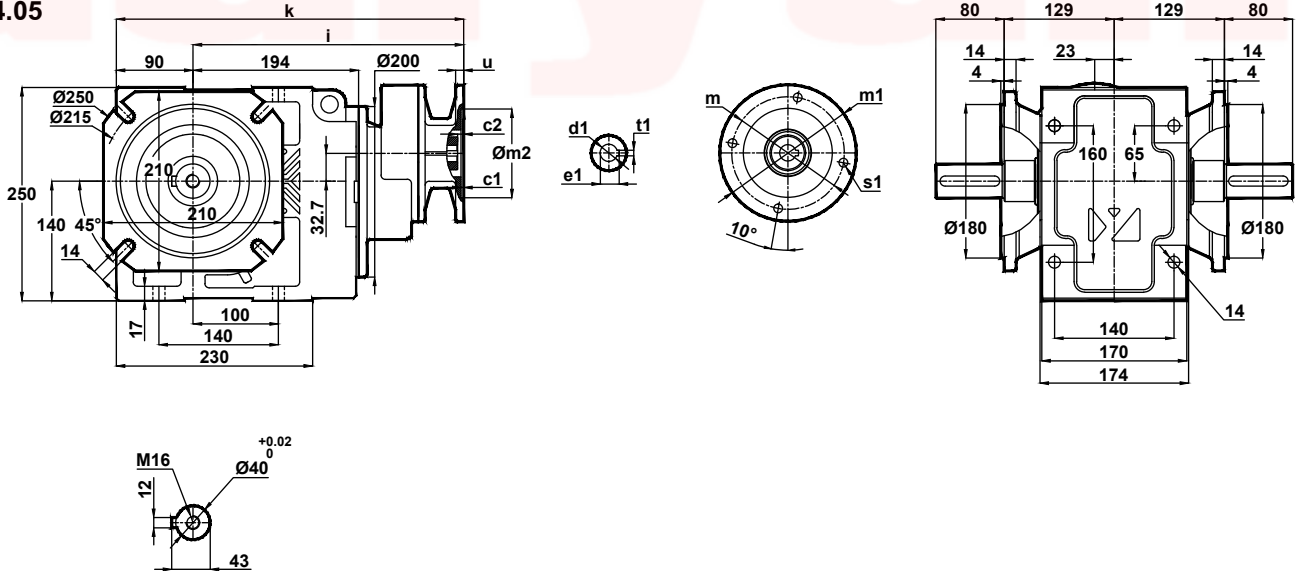

	c1	c2	s1	m	m1	m2	i1	u	k	d1	t1	e1
63/B5	4	8	9	115	140	95	338	12	356	11	4	12.8
71/B5	4	8.5	11	130	160	110	309	12	327	14	5	16.3
80/B5	4	5	13	165	200	130	338	12	356	19	6	21.8
90/B5	4	5	13	165	200	130	338	12	356	24	8	27.3
100/B5	4	5.5	15	215	250	180	331	12	349	28	8	31.3
112/B5	4	5.5	15	215	250	180	331	12	349	28	8	31.3



# Ölçü Sayfaları Dimension Pages Abmessungenseiten



-Mil ucu çekirme deliği DIN 332 sayfa 2 / Tapped center hole to DIN 332, sheet 2 / Zentrierung mit gewinde DIN 332, Blatt 2

KN374.08

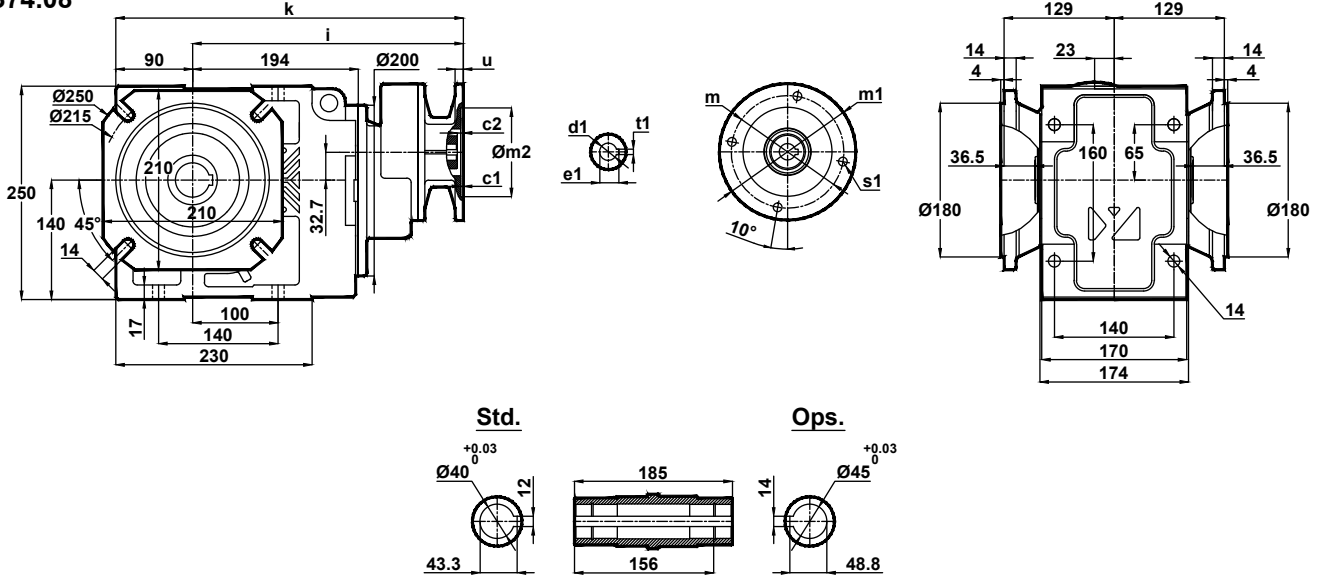

	c1	c2	s1	m	m1	m2	i1	u	k	d1	t1	e1
63/B5	4	8	9	115	140	95	338	12	356	11	4	12.8
71/B5	4	8.5	11	130	160	110	309	12	327	14	5	16.3
80/B5	4	5	13	165	200	130	338	12	356	19	6	21.8
90/B5	4	5	13	165	200	130	338	12	356	24	8	27.3
100/B5	4	5.5	15	215	250	180	331	12	349	28	8	31.3
112/B5	4	5.5	15	215	250	180	331	12	349	28	8	31.3



# Ölçü Sayfaları

## Dimension Pages

### Abmessungsseiten



-Mil ucu çekirme deliği DIN 332 sayfa 2 / Tapped center hole to DIN 332, sheet 2 / Zentrierung mit gewinde DIN 332, Blatt 2

KN375.00  
KN376.00

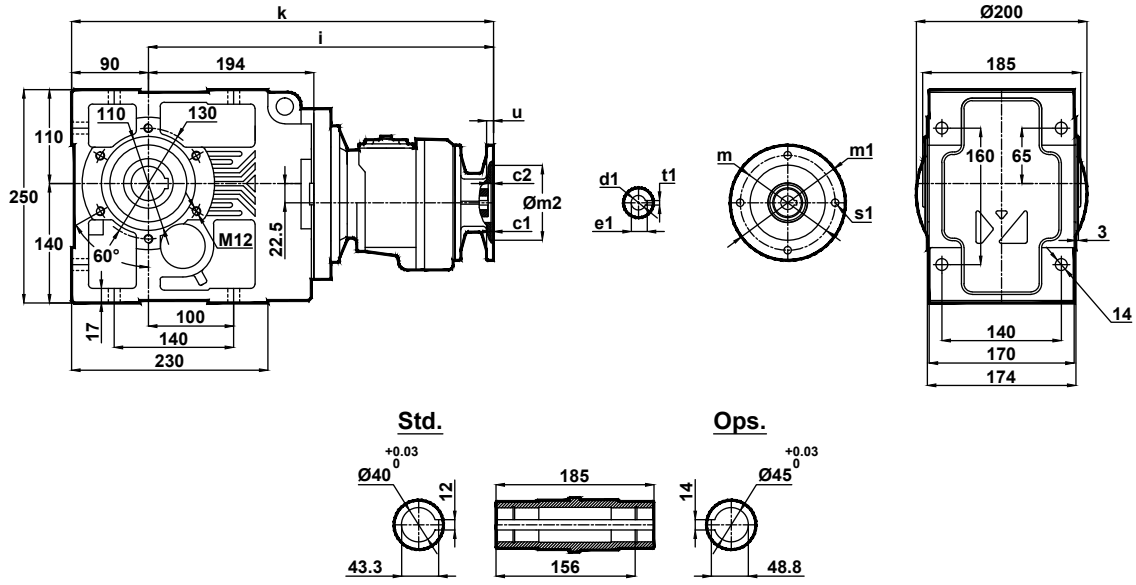

	c1	c2	s1	m	m1	m2	i1	u	k	d1	t1	e1
63/B5	3.5	5	10	115	140	95	405	10	495	11	4	12.8
71/B5	4	4.5	11	130	160	110	405	12	495	14	5	16.3
80/B5	4	5	13	165	200	130	420	12	510	19	6	21.8
90/B5	4	5	13	165	200	130	420	12	510	24	8	27.3

KN375.01  
KN376.01

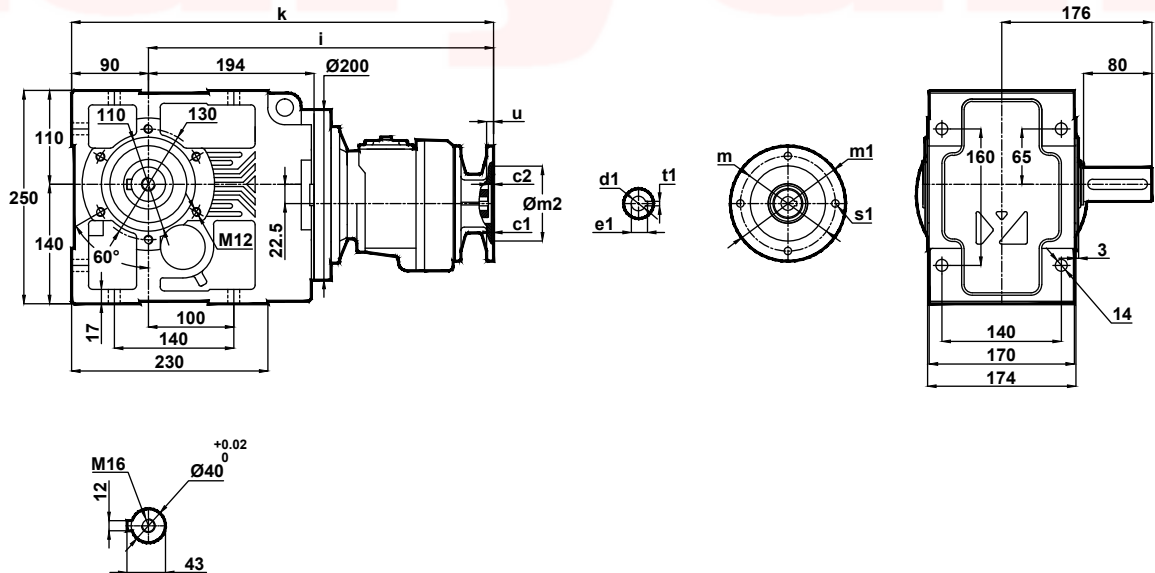

	c1	c2	s1	m	m1	m2	i1	u	k	d1	t1	e1
63/B5	3.5	5	10	115	140	95	405	10	495	11	4	12.8
71/B5	4	4.5	11	130	160	110	405	12	495	14	5	16.3
80/B5	4	5	13	165	200	130	420	12	510	19	6	21.8
90/B5	4	5	13	165	200	130	420	12	510	24	8	27.3





# Ölçü Sayfaları

## Dimension Pages

### Abmessungsseiten



-Mil ucu çekirme deliği DIN 332 sayfa 2 / Tapped center hole to DIN 332, sheet 2 / Zentrierung mit gewinde DIN 332, Blatt 2

KN375.02  
KN376.02

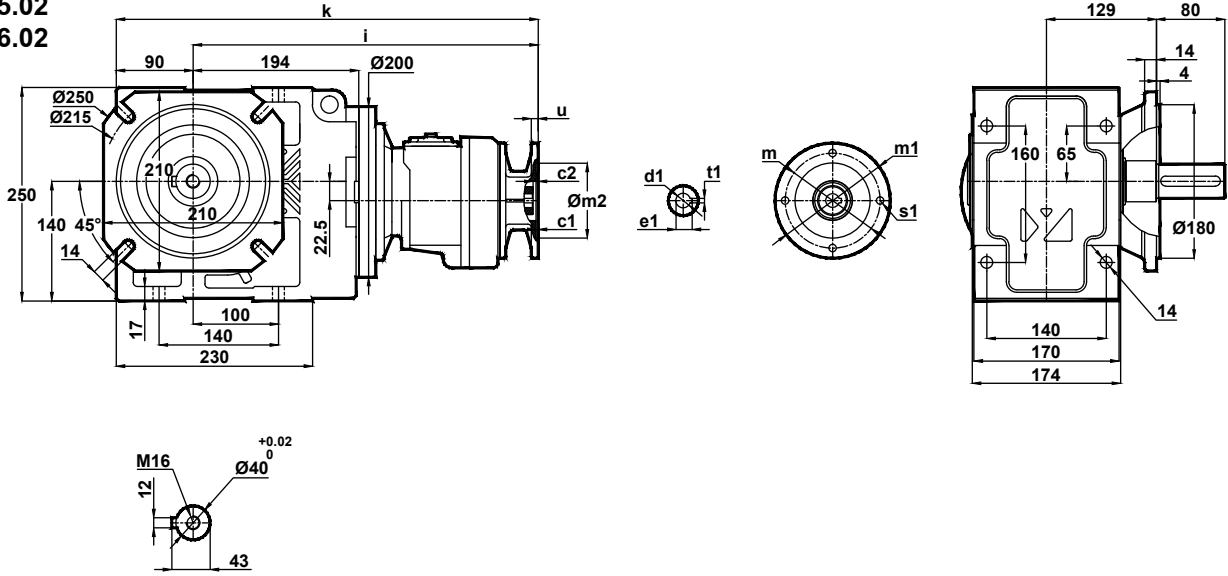

	c1	c2	s1	m	m1	m2	i1	u	k	d1	t1	e1
63/B5	3.5	5	10	115	140	95	405	10	495	11	4	12.8
71/B5	4	4.5	11	130	160	110	405	12	495	14	5	16.3
80/B5	4	5	13	165	200	130	420	12	510	19	6	21.8
90/B5	4	5	13	165	200	130	420	12	510	24	8	27.3

KN375.03  
KN376.03

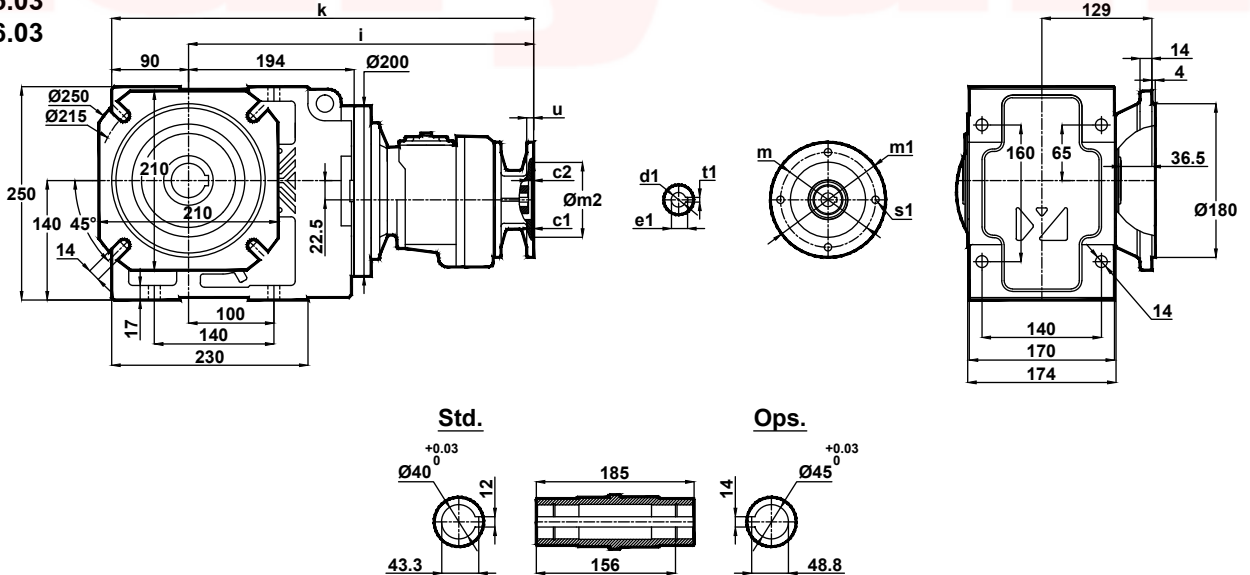

	c1	c2	s1	m	m1	m2	i1	u	k	d1	t1	e1
63/B5	3.5	5	10	115	140	95	405	10	495	11	4	12.8
71/B5	4	4.5	11	130	160	110	405	12	495	14	5	16.3
80/B5	4	5	13	165	200	130	420	12	510	19	6	21.8
90/B5	4	5	13	165	200	130	420	12	510	24	8	27.3



# Ölçü Sayfaları Dimension Pages Abmessungsseiten



-Mil ucu çekirme deliği DIN 332 sayfa 2 / Tapped center hole to DIN 332, sheet 2 / Zentrierung mit gewinde DIN 332, Blatt 2

KN375.04  
KN376.04

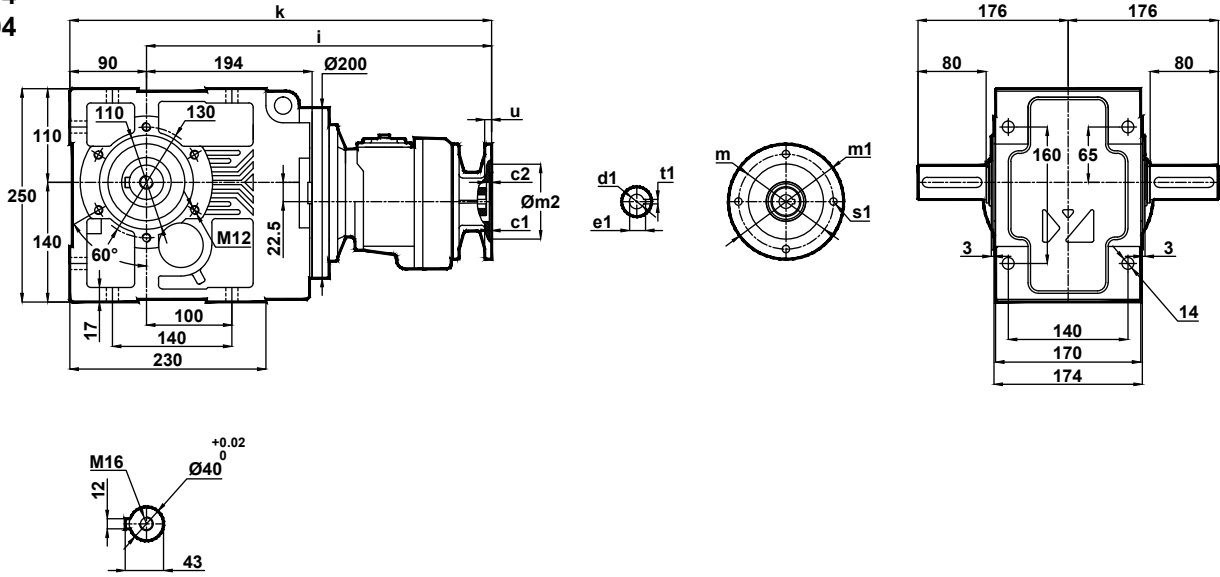

	c1	c2	s1	m	m1	m2	i1	u	k	d1	t1	e1
63/B5	3.5	5	10	115	140	95	405	10	495	11	4	12.8
71/B5	4	4.5	11	130	160	110	405	12	495	14	5	16.3
80/B5	4	5	13	165	200	130	420	12	510	19	6	21.8
90/B5	4	5	13	165	200	130	420	12	510	24	8	27.3

KN375.05  
KN376.05

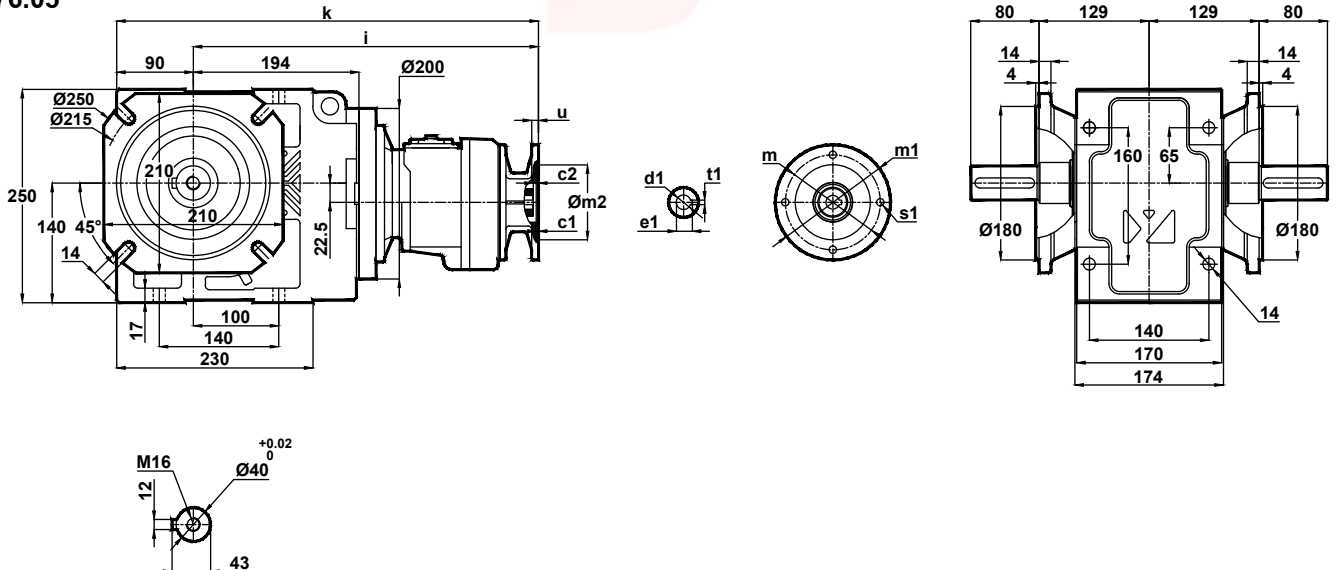

	c1	c2	s1	m	m1	m2	i1	u	k	d1	t1	e1
63/B5	3.5	5	10	115	140	95	405	10	495	11	4	12.8
71/B5	4	4.5	11	130	160	110	405	12	495	14	5	16.3
80/B5	4	5	13	165	200	130	420	12	510	19	6	21.8
90/B5	4	5	13	165	200	130	420	12	510	24	8	27.3



# Ölçü Sayfaları Dimension Pages Abmessungenseiten



-Mil ucu çektirme deliği DIN 332 sayfa 2 / Tapped center hole to DIN 332, sheet 2 / Zentrierung mit gewinde DIN 332, Blatt 2

KN375.08  
KN376.08

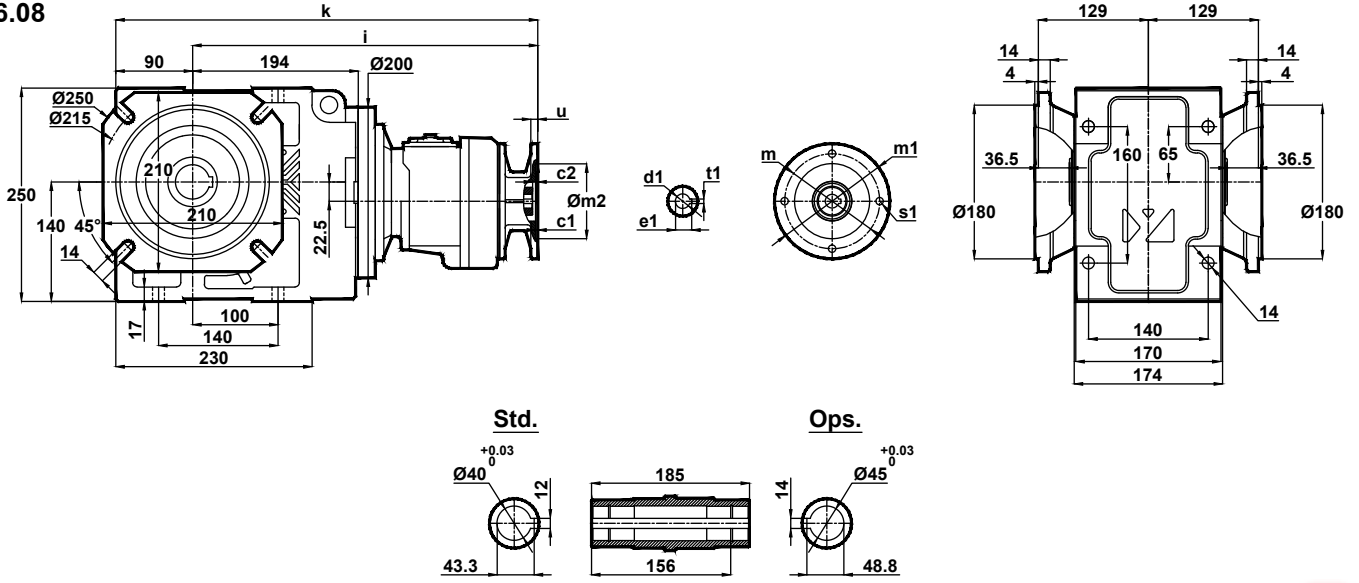

	c1	c2	s1	m	m1	m2	i1	u	k	d1	t1	e1
63/B5	3.5	5	10	115	140	95	405	10	495	11	4	12.8
71/B5	4	4.5	11	130	160	110	405	12	495	14	5	16.3
80/B5	4	5	13	165	200	130	420	12	510	19	6	21.8
90/B5	4	5	13	165	200	130	420	12	510	24	8	27.3



# Ölçü Sayfaları

## Dimension Pages

### Abmessungsseiten



-Mil ucu çekirme deliği DIN 332 sayfa 2 / Tapped center hole to DIN 332, sheet 2 / Zentrierung mit gewinde DIN 332, Blatt 2

#### KN473.00

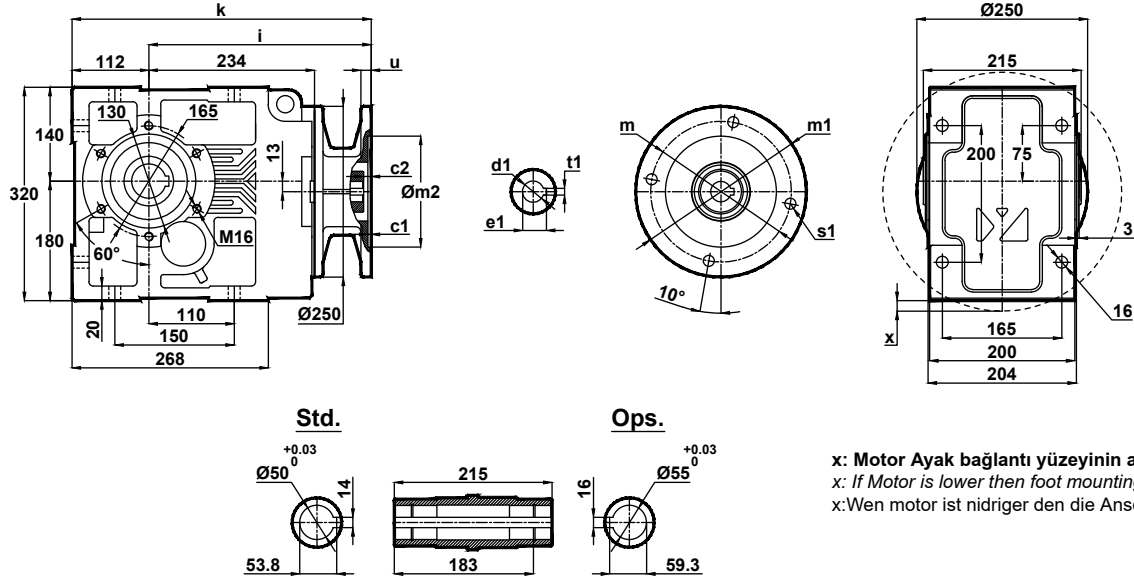

	c1	c2	s1	m	m1	m2	i1	u	k	d1	t1	e1	x
80/B5	4	5	12	162	200	130	57	12	459	19	6	21.8	-
90/B5	4	5	13	165	200	130	57	12	459	24	8	27.3	-
100/B5	4.5	9	15	215	250	180	75	15	478	28	8	31.3	-
112/B5	4.5	9	15	215	250	180	75	15	478	28	8	31.3	-
132/B5	4.5	6	15	265	300	230	94	15	496	38	10	41.3	-
160/B5	5.5	10	19	300	350	250	173	20	576	42	12	45.3	8
180/B5	5.5	10	19	300	350	250	173	20	576	48	14	51.8	8

#### KN473.01

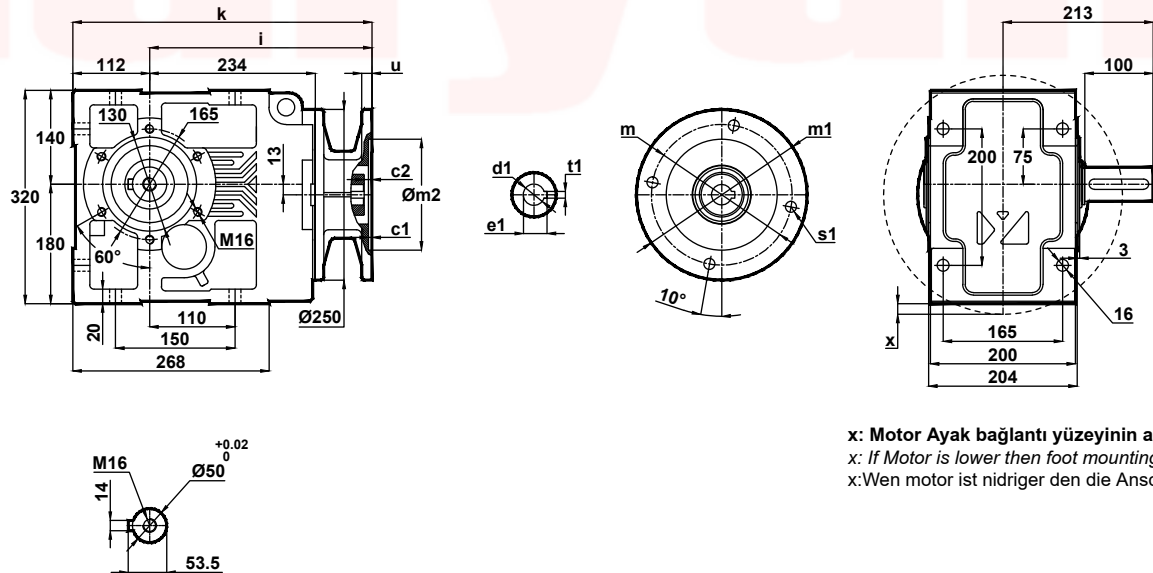

	c1	c2	s1	m	m1	m2	i1	u	k	d1	t1	e1	x
80/B5	4	5	12	162	200	130	57	12	459	19	6	21.8	-
90/B5	4	5	13	165	200	130	57	12	459	24	8	27.3	-
100/B5	4.5	9	15	215	250	180	75	15	478	28	8	31.3	-
112/B5	4.5	9	15	215	250	180	75	15	478	28	8	31.3	-
132/B5	4.5	6	15	265	300	230	94	15	496	38	10	41.3	-
160/B5	5.5	10	19	300	350	250	173	20	576	42	12	45.3	8
180/B5	5.5	10	19	300	350	250	173	20	576	48	14	51.8	8



# Ölçü Sayfaları

## Dimension Pages

### Abmessungsseiten



-Mil ucu çektirme deliği DIN 332 sayfa 2 / Tapped center hole to DIN 332, sheet 2 / Zentrierung mit gewinde DIN 332, Blatt 2

#### KN473.02

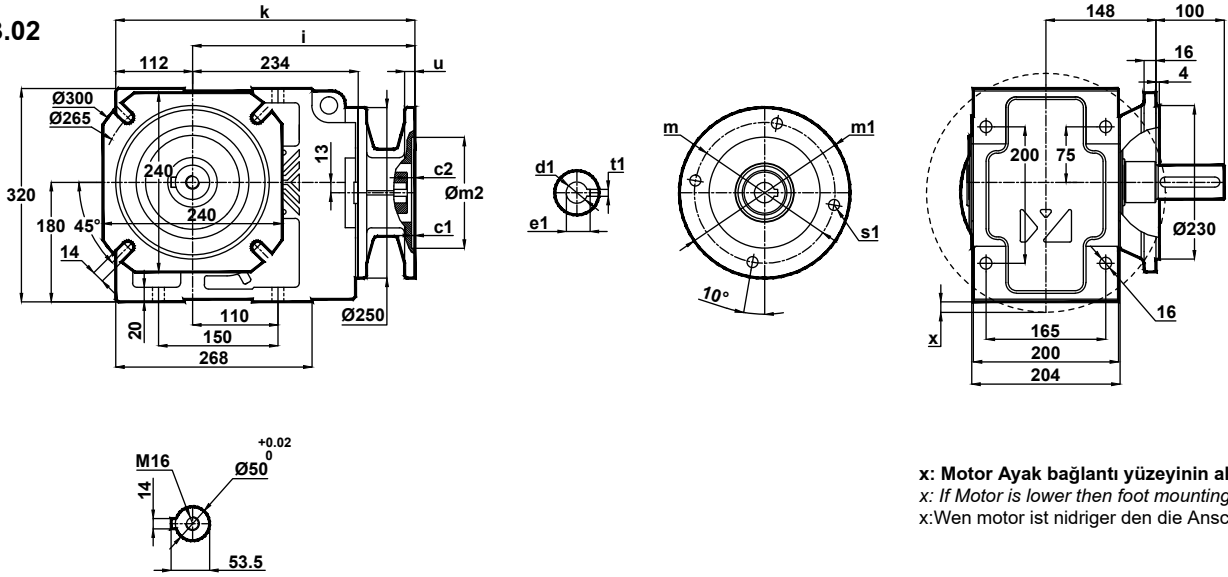

x: Motor Ayak bağlantı yüzeyinin altında ise  
x: If Motor is lower then foot mounting plane  
x: Wenn motor ist niedriger den die Anschlußplatte

	c1	c2	s1	m	m1	m2	i1	u	k	d1	t1	e1	x
80/B5	4	5	12	162	200	130	57	12	459	19	6	21.8	-
90/B5	4	5	13	165	200	130	57	12	459	24	8	27.3	-
100/B5	4.5	9	15	215	250	180	75	15	478	28	8	31.3	-
112/B5	4.5	9	15	215	250	180	75	15	478	28	8	31.3	-
132/B5	4.5	6	15	265	300	230	94	15	496	38	10	41.3	-
160/B5	5.5	10	19	300	350	250	173	20	576	42	12	45.3	8
180/B5	5.5	10	19	300	350	250	173	20	576	48	14	51.8	8

#### KN473.03

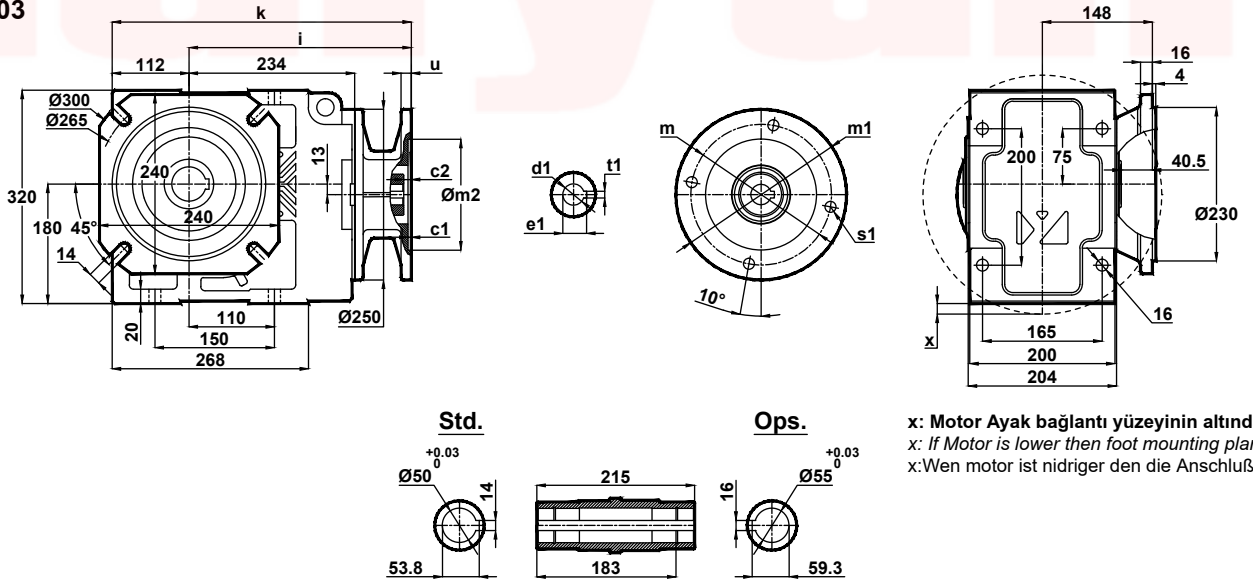

x: Motor Ayak bağlantı yüzeyinin altında ise  
x: If Motor is lower then foot mounting plane  
x: Wenn motor ist niedriger den die Anschlußplatte

	c1	c2	s1	m	m1	m2	i1	u	k	d1	t1	e1	x
80/B5	4	5	12	162	200	130	57	12	459	19	6	21.8	-
90/B5	4	5	13	165	200	130	57	12	459	24	8	27.3	-
100/B5	4.5	9	15	215	250	180	75	15	478	28	8	31.3	-
112/B5	4.5	9	15	215	250	180	75	15	478	28	8	31.3	-
132/B5	4.5	6	15	265	300	230	94	15	496	38	10	41.3	-
160/B5	5.5	10	19	300	350	250	173	20	576	42	12	45.3	8
180/B5	5.5	10	19	300	350	250	173	20	576	48	14	51.8	8



# Ölçü Sayfaları

## Dimension Pages

### Abmessungsseiten



-Mil ucu çekirme deliği DIN 332 sayfa 2 / Tapped center hole to DIN 332, sheet 2 / Zentrierung mit gewinde DIN 332, Blatt 2

#### KN473.04

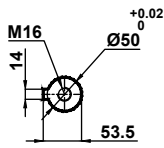
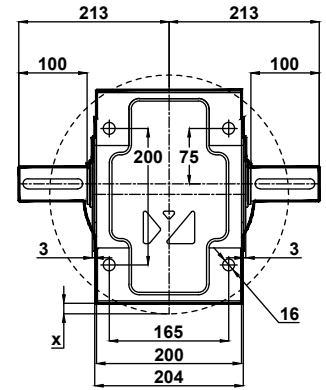
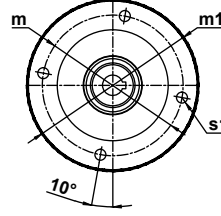
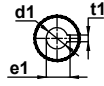
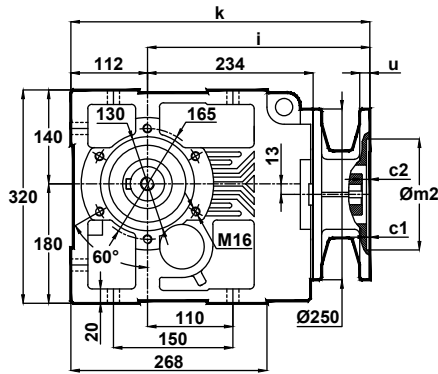

x: Motor Ayak bağlantı yüzeyinin altında ise  
x: If Motor is lower then foot mounting plane  
x: Wenn motor ist niedriger den die Anschlußplatte

	c1	c2	s1	m	m1	m2	i1	u	k	d1	t1	e1	x
80/B5	4	5	12	162	200	130	57	12	459	19	6	21.8	-
90/B5	4	5	13	165	200	130	57	12	459	24	8	27.3	-
100/B5	4.5	9	15	215	250	180	75	15	478	28	8	31.3	-
112/B5	4.5	9	15	215	250	180	75	15	478	28	8	31.3	-
132/B5	4.5	6	15	265	300	230	94	15	496	38	10	41.3	-
160/B5	5.5	10	19	300	350	250	173	20	576	42	12	45.3	8
180/B5	5.5	10	19	300	350	250	173	20	576	48	14	51.8	8

#### KN473.05

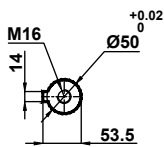
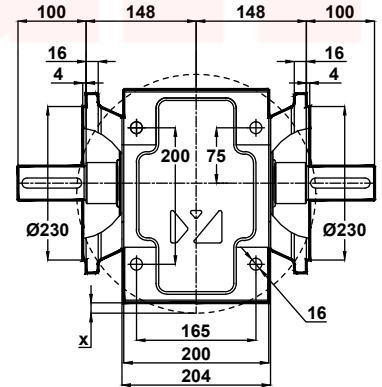
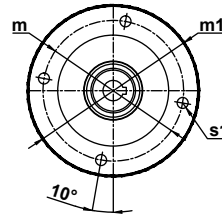
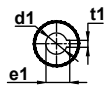
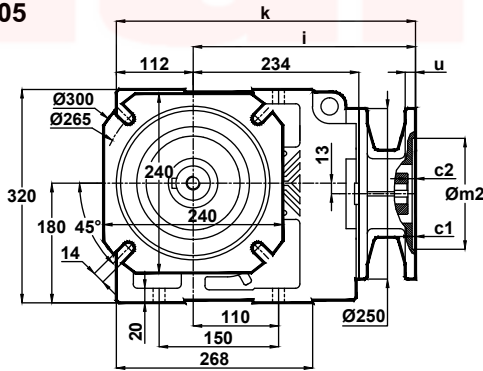

x: Motor Ayak bağlantı yüzeyinin altında ise  
x: If Motor is lower then foot mounting plane  
x: Wenn motor ist niedriger den die Anschlußplatte

	c1	c2	s1	m	m1	m2	i1	u	k	d1	t1	e1	x
80/B5	4	5	12	162	200	130	57	12	459	19	6	21.8	-
90/B5	4	5	13	165	200	130	57	12	459	24	8	27.3	-
100/B5	4.5	9	15	215	250	180	75	15	478	28	8	31.3	-
112/B5	4.5	9	15	215	250	180	75	15	478	28	8	31.3	-
132/B5	4.5	6	15	265	300	230	94	15	496	38	10	41.3	-
160/B5	5.5	10	19	300	350	250	173	20	576	42	12	45.3	8
180/B5	5.5	10	19	300	350	250	173	20	576	48	14	51.8	8



# Ölçü Sayfaları Dimension Pages Abmessungsseiten



-Mil ucu çektirme deliği DIN 332 sayfa 2 / Tapped center hole to DIN 332, sheet 2 / Zentrierung mit gewinde DIN 332, Blatt 2

KN473.08

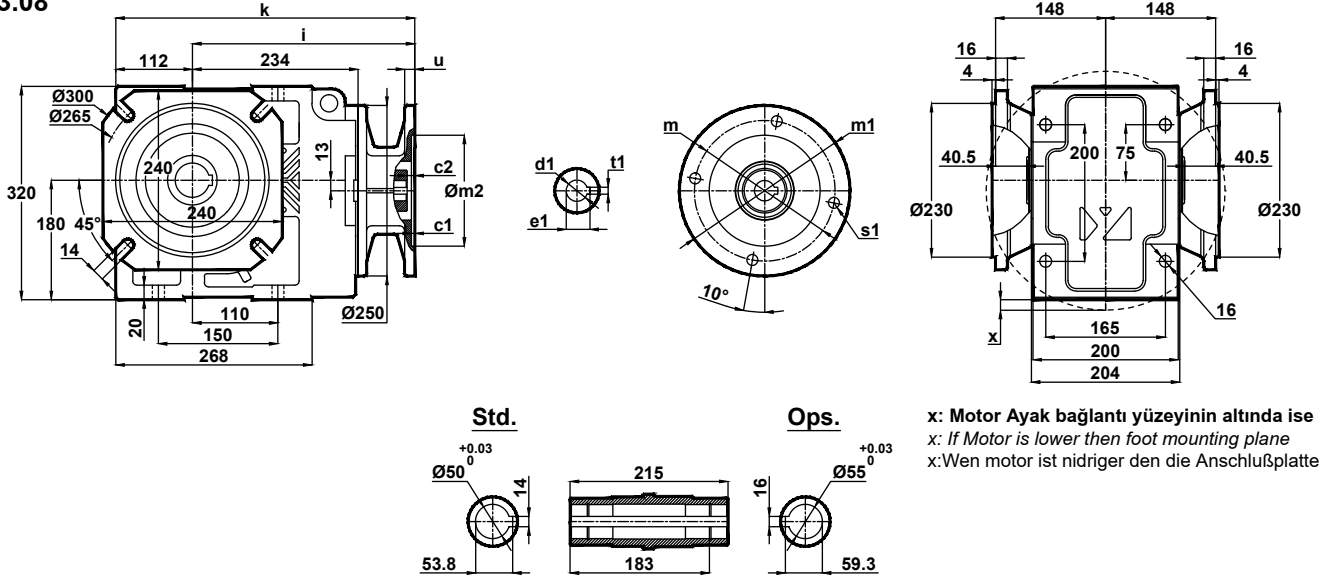

x: Motor Ayak bağlantı yüzeyinin altında ise  
x: If Motor is lower then foot mounting plane  
x: Wenn motor ist niedriger den die Anschlussplatte

	c1	c2	s1	m	m1	m2	i1	u	k	d1	t1	e1	x
80/B5	4	5	12	162	200	130	57	12	459	19	6	21.8	-
90/B5	4	5	13	165	200	130	57	12	459	24	8	27.3	-
100/B5	4.5	9	15	215	250	180	75	15	478	28	8	31.3	-
112/B5	4.5	9	15	215	250	180	75	15	478	28	8	31.3	-
132/B5	4.5	6	15	265	300	230	94	15	496	38	10	41.3	-
160/B5	5.5	10	19	300	350	250	173	20	576	42	12	45.3	8
180/B5	5.5	10	19	300	350	250	173	20	576	48	14	51.8	8



# Ölçü Sayfaları Dimension Pages Abmessungenseiten



-Mil ucu çektirme deliği DIN 332 sayfa 2 / Tapped center hole to DIN 332, sheet 2 / Zentrierung mit gewinde DIN 332, Blatt 2

## KN474.00

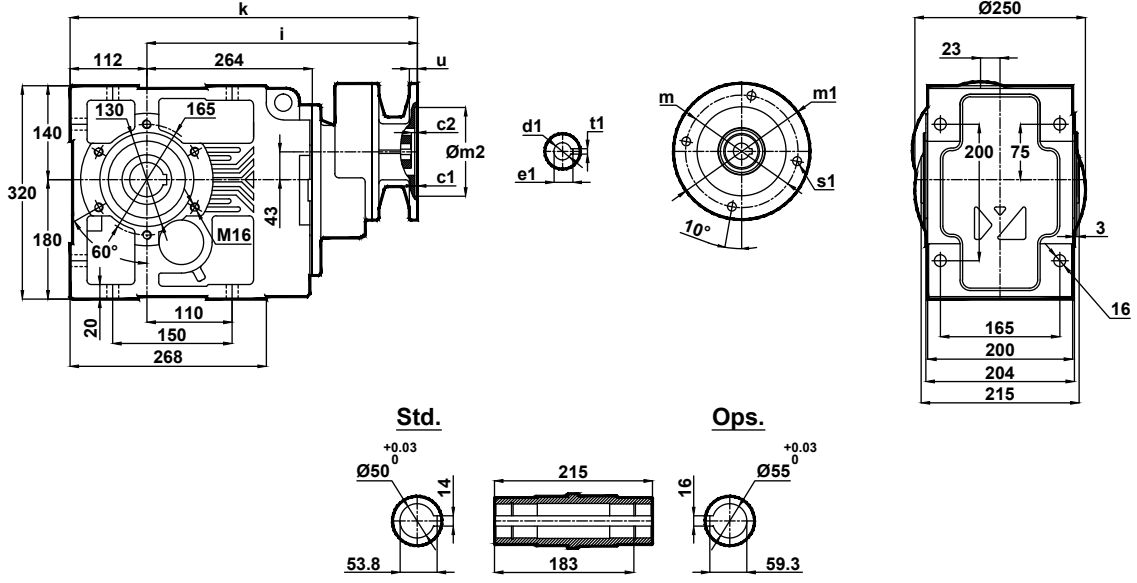

	c1	c2	s1	m	m1	m2	i1	u	k	d1	t1	e1
71/B5	4	9	11	130	160	110	389	12	417	14	5	16.3
80/B5	4	9	13	165	200	130	389	12	417	19	6	21.8
90/B5	4	9	13	165	200	130	389	12	417	24	8	27.3
100/B5	4.5	9	15	215	250	180	406	15	434	28	8	31.3
112/B5	4.5	9	15	215	250	180	406	15	434	28	8	31.3
132/B5	4.5	7	15	265	300	230	426	15	454	38	10	41.3

## KN474.01

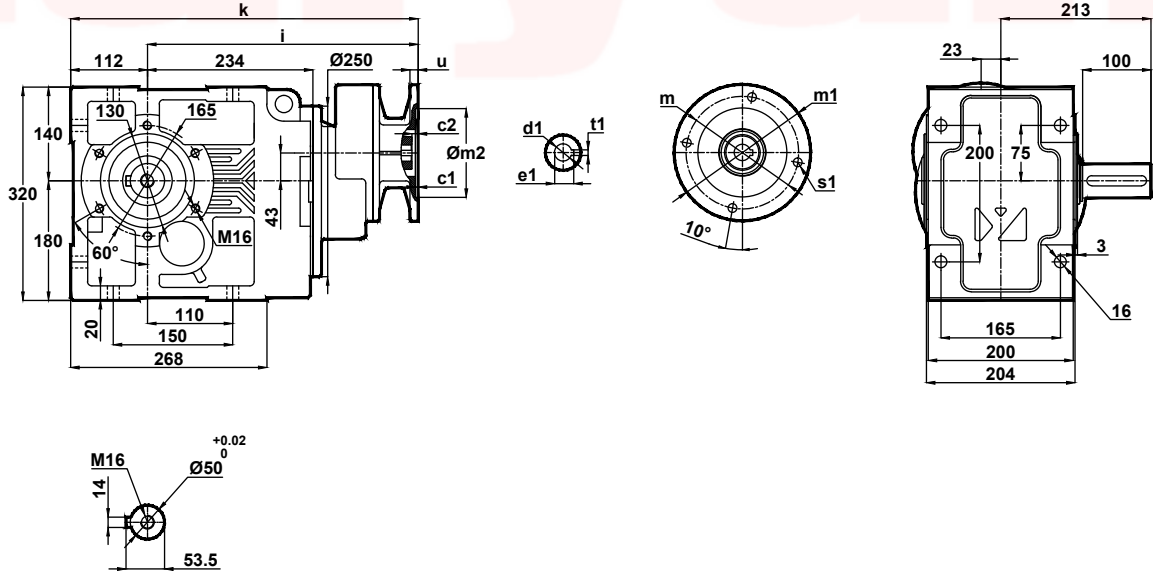

	c1	c2	s1	m	m1	m2	i1	u	k	d1	t1	e1
71/B5	4	9	11	130	160	110	389	12	417	14	5	16.3
80/B5	4	9	13	165	200	130	389	12	417	19	6	21.8
90/B5	4	9	13	165	200	130	389	12	417	24	8	27.3
100/B5	4.5	9	15	215	250	180	406	15	434	28	8	31.3
112/B5	4.5	9	15	215	250	180	406	15	434	28	8	31.3
132/B5	4.5	7	15	265	300	230	426	15	454	38	10	41.3





# Ölçü Sayfaları

## Dimension Pages

### Abmessungsseiten



-Mil ucu çekirme deliği DIN 332 sayfa 2 / Tapped center hole to DIN 332, sheet 2 / Zentrierung mit gewinde DIN 332, Blatt 2

#### KN474.02

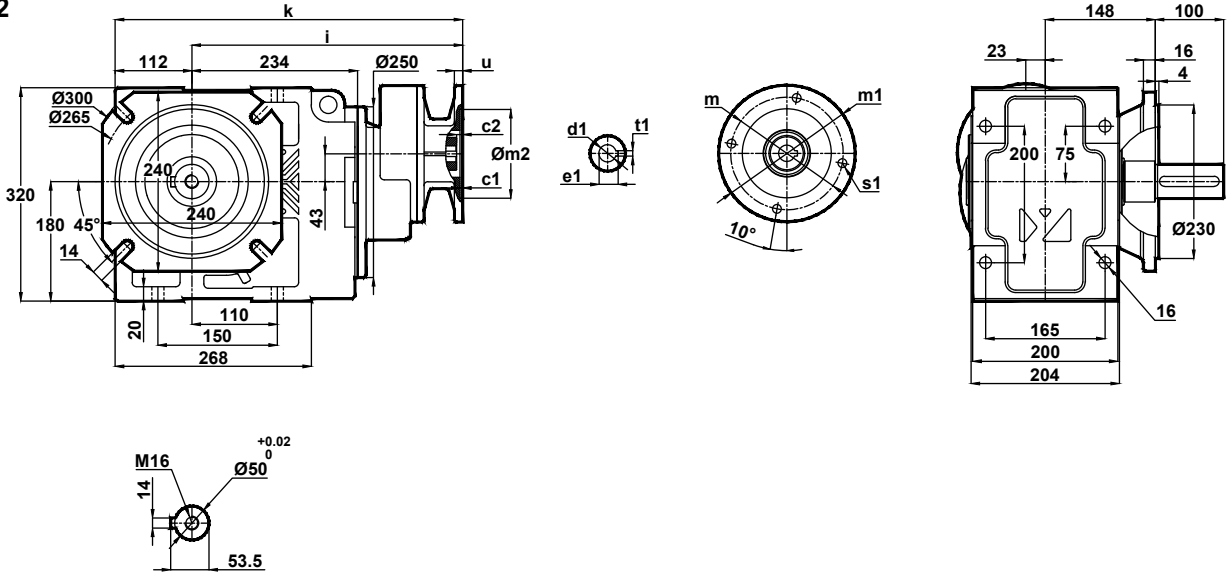

	c1	c2	s1	m	m1	m2	i1	u	k	d1	t1	e1
71/B5	4	9	11	130	160	110	389	12	417	14	5	16.3
80/B5	4	9	13	165	200	130	389	12	417	19	6	21.8
90/B5	4	9	13	165	200	130	389	12	417	24	8	27.3
100/B5	4.5	9	15	215	250	180	406	15	434	28	8	31.3
112/B5	4.5	9	15	215	250	180	406	15	434	28	8	31.3
132/B5	4.5	7	15	265	300	230	426	15	454	38	10	41.3

#### KN474.03

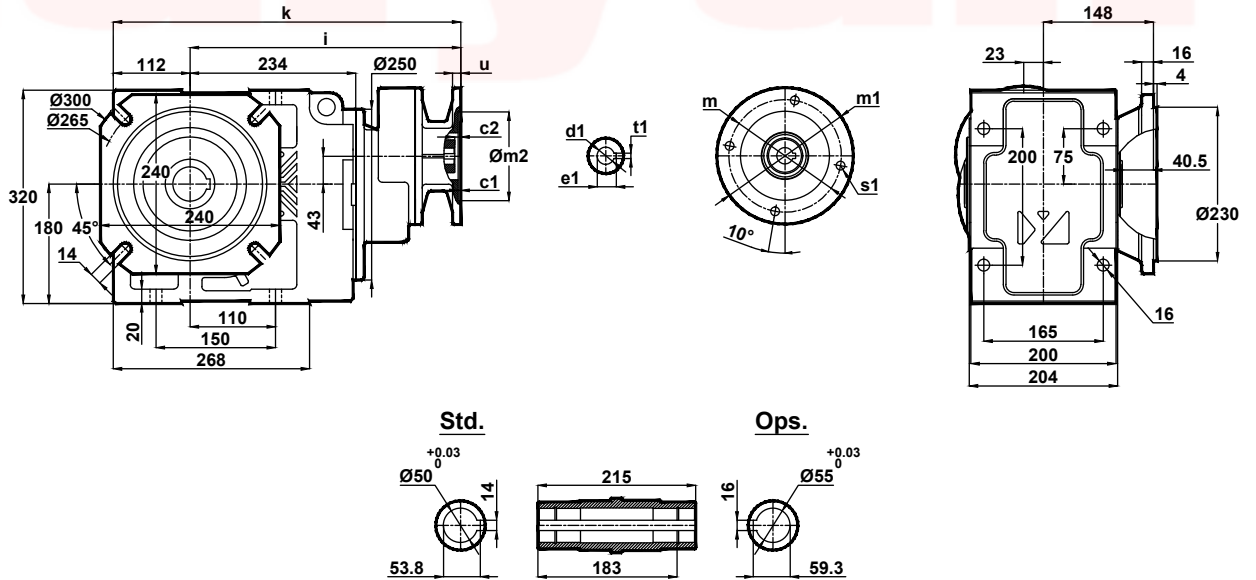

	c1	c2	s1	m	m1	m2	i1	u	k	d1	t1	e1
71/B5	4	9	11	130	160	110	389	12	417	14	5	16.3
80/B5	4	9	13	165	200	130	389	12	417	19	6	21.8
90/B5	4	9	13	165	200	130	389	12	417	24	8	27.3
100/B5	4.5	9	15	215	250	180	406	15	434	28	8	31.3
112/B5	4.5	9	15	215	250	180	406	15	434	28	8	31.3
132/B5	4.5	7	15	265	300	230	426	15	454	38	10	41.3



# Ölçü Sayfaları

## Dimension Pages

### Abmessungsseiten



-Mil ucu çekirme deliği DIN 332 sayfa 2 / Tapped center hole to DIN 332, sheet 2 / Zentrierung mit gewinde DIN 332, Blatt 2

#### KN474.04

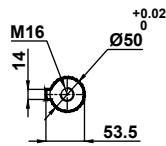
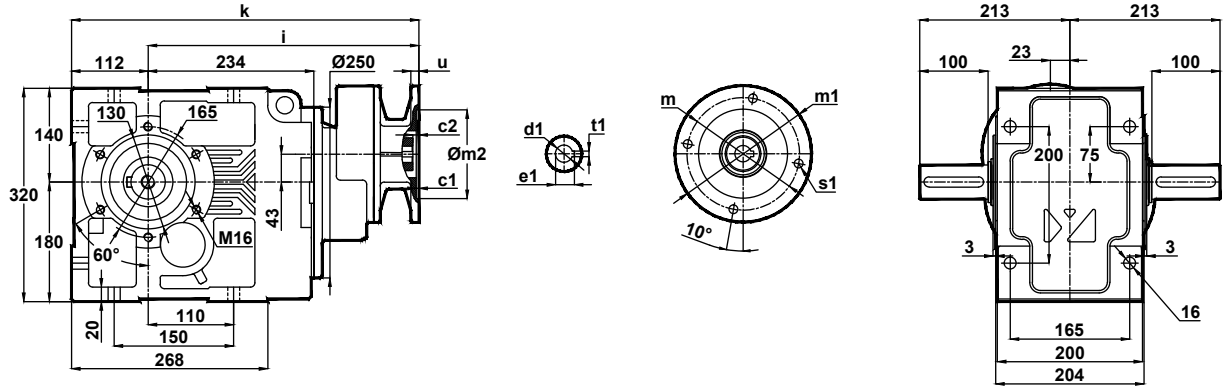

	c1	c2	s1	m	m1	m2	i1	u	k	d1	t1	e1
71/B5	4	9	11	130	160	110	389	12	417	14	5	16.3
80/B5	4	9	13	165	200	130	389	12	417	19	6	21.8
90/B5	4	9	13	165	200	130	389	12	417	24	8	27.3
100/B5	4.5	9	15	215	250	180	406	15	434	28	8	31.3
112/B5	4.5	9	15	215	250	180	406	15	434	28	8	31.3
132/B5	4.5	7	15	265	300	230	426	15	454	38	10	41.3

#### KN474.05

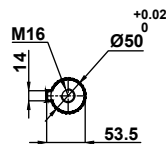
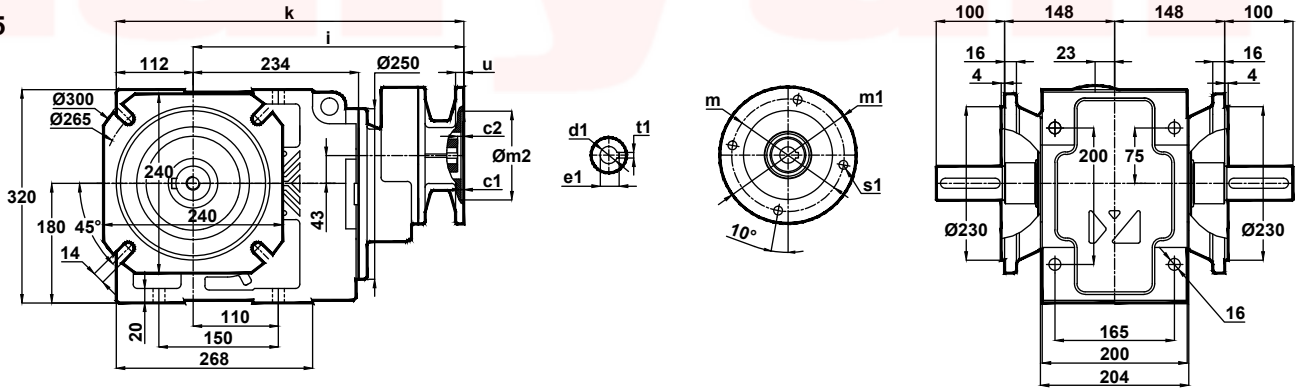

	c1	c2	s1	m	m1	m2	i1	u	k	d1	t1	e1
71/B5	4	9	11	130	160	110	389	12	417	14	5	16.3
80/B5	4	9	13	165	200	130	389	12	417	19	6	21.8
90/B5	4	9	13	165	200	130	389	12	417	24	8	27.3
100/B5	4.5	9	15	215	250	180	406	15	434	28	8	31.3
112/B5	4.5	9	15	215	250	180	406	15	434	28	8	31.3
132/B5	4.5	7	15	265	300	230	426	15	454	38	10	41.3



# Ölçü Sayfaları Dimension Pages Abmessungenseiten



-Mil ucu çekirme deliği DIN 332 sayfa 2 / Tapped center hole to DIN 332, sheet 2 / Zentrierung mit gewinde DIN 332, Blatt 2

KN474.08

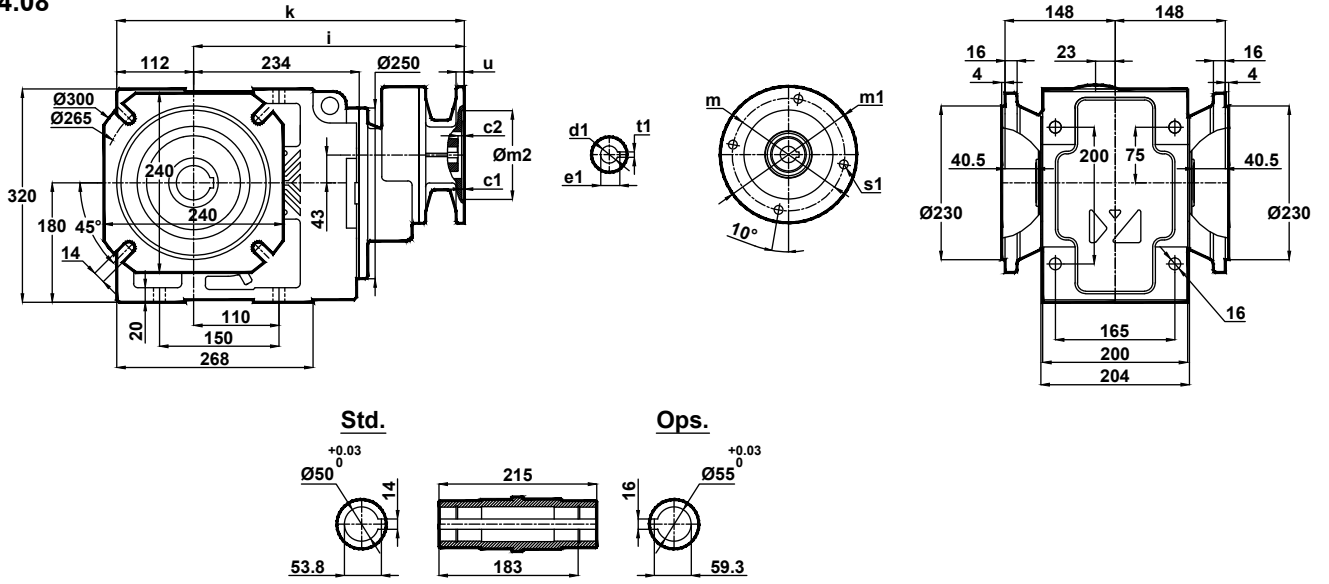

	c1	c2	s1	m	m1	m2	i1	u	k	d1	t1	e1
71/B5	4	9	11	130	160	110	389	12	417	14	5	16.3
80/B5	4	9	13	165	200	130	389	12	417	19	6	21.8
90/B5	4	9	13	165	200	130	389	12	417	24	8	27.3
100/B5	4.5	9	15	215	250	180	406	15	434	28	8	31.3
112/B5	4.5	9	15	215	250	180	406	15	434	28	8	31.3
132/B5	4.5	7	15	265	300	230	426	15	454	38	10	41.3



# Ölçü Sayfaları

## Dimension Pages

### Abmessungsseiten



-Mil ucu çekirme deliği DIN 332 sayfa 2 / Tapped center hole to DIN 332, sheet 2 / Zentrierung mit gewinde DIN 332, Blatt 2

KN475.00  
KN476.00

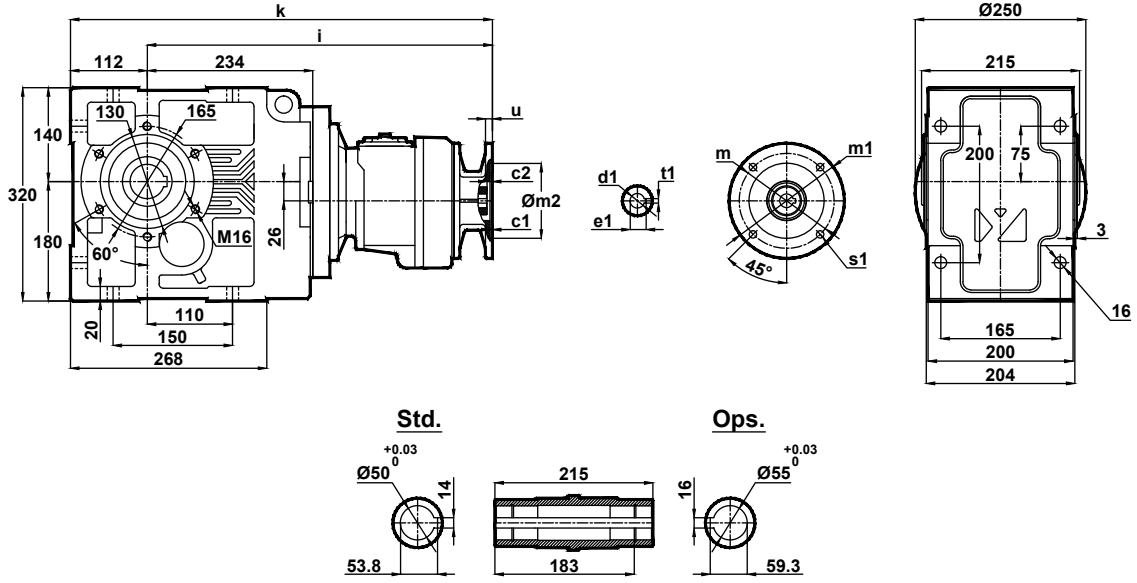

	c1	c2	s1	m	m1	m2	i1	u	k	d1	t1	e1
63/B5	4	8	9	115	140	95	517	12	629	11	4	12.8
71/B5	4	8.5	11	130	160	110	488	12	600	14	5	16.3
80/B5	4	5	13	165	200	130	517	12	629	19	6	21.8
90/B5	4	5	13	165	200	130	517	12	629	24	8	27.3
100/B5	4	5.5	15	215	250	180	510	12	622	28	8	31.3
112/B5	4	5.5	15	215	250	180	510	12	622	28	8	31.3

KN475.01  
KN476.01

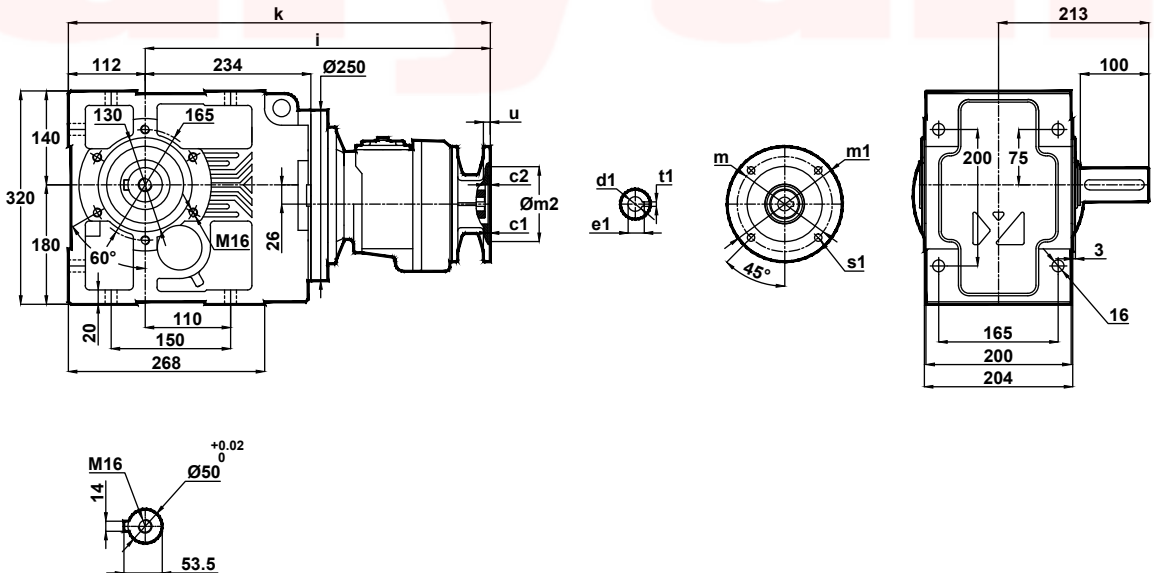

	c1	c2	s1	m	m1	m2	i1	u	k	d1	t1	e1
63/B5	4	8	9	115	140	95	517	12	629	11	4	12.8
71/B5	4	8.5	11	130	160	110	488	12	600	14	5	16.3
80/B5	4	5	13	165	200	130	517	12	629	19	6	21.8
90/B5	4	5	13	165	200	130	517	12	629	24	8	27.3
100/B5	4	5.5	15	215	250	180	510	12	622	28	8	31.3
112/B5	4	5.5	15	215	250	180	510	12	622	28	8	31.3



# Ölçü Sayfaları Dimension Pages Abmessungsseiten



-Mil ucu çekirme deliği DIN 332 sayfa 2 / Tapped center hole to DIN 332, sheet 2 / Zentrierung mit gewinde DIN 332, Blatt 2

KN475.02  
KN476.02

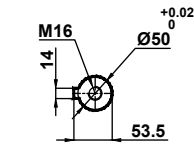
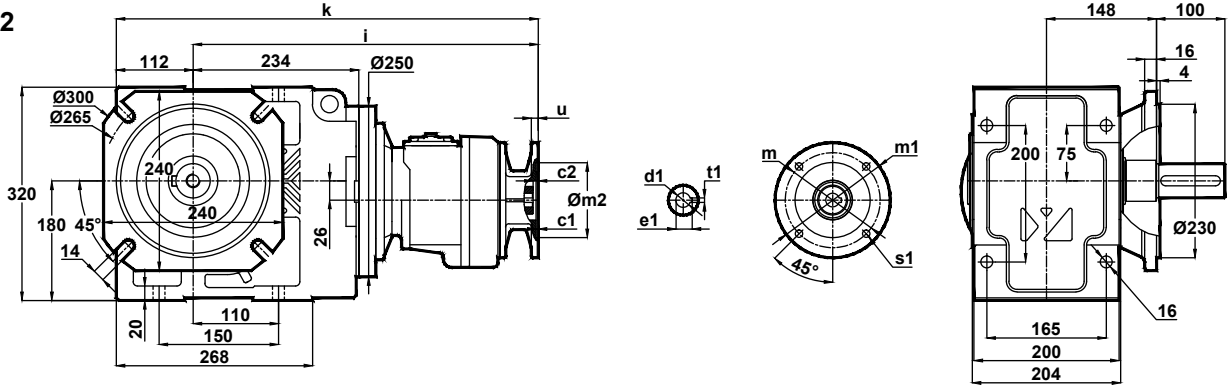

	c1	c2	s1	m	m1	m2	i1	u	k	d1	t1	e1
63/B5	4	8	9	115	140	95	517	12	629	11	4	12.8
71/B5	4	8.5	11	130	160	110	488	12	600	14	5	16.3
80/B5	4	5	13	165	200	130	517	12	629	19	6	21.8
90/B5	4	5	13	165	200	130	517	12	629	24	8	27.3
100/B5	4	5.5	15	215	250	180	510	12	622	28	8	31.3
112/B5	4	5.5	15	215	250	180	510	12	622	28	8	31.3

KN475.03  
KN476.03

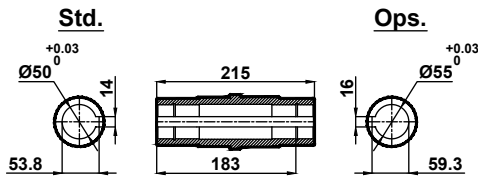
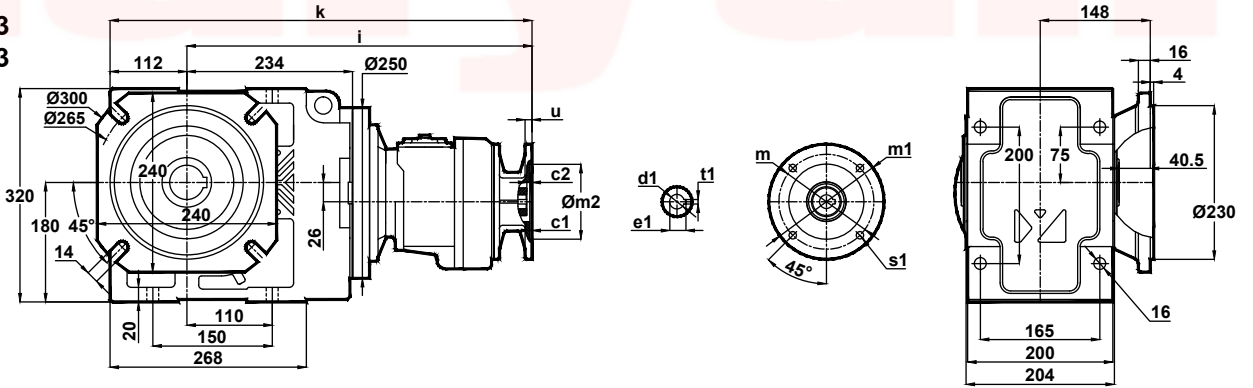

	c1	c2	s1	m	m1	m2	i1	u	k	d1	t1	e1
63/B5	4	8	9	115	140	95	517	12	629	11	4	12.8
71/B5	4	8.5	11	130	160	110	488	12	600	14	5	16.3
80/B5	4	5	13	165	200	130	517	12	629	19	6	21.8
90/B5	4	5	13	165	200	130	517	12	629	24	8	27.3
100/B5	4	5.5	15	215	250	180	510	12	622	28	8	31.3
112/B5	4	5.5	15	215	250	180	510	12	622	28	8	31.3



# Ölçü Sayfaları Dimension Pages Abmessungsseiten



-Mil ucu çekirme deliği DIN 332 sayfa 2 / Tapped center hole to DIN 332, sheet 2 / Zentrierung mit gewinde DIN 332, Blatt 2

KN475.04  
KN476.04

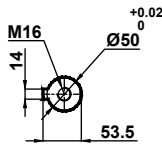
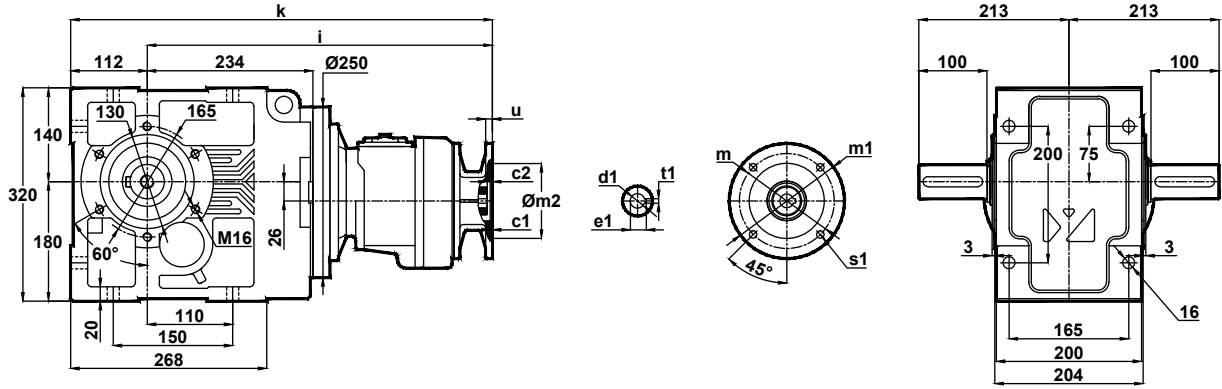

	c1	c2	s1	m	m1	m2	i1	u	k	d1	t1	e1
63/B5	4	8	9	115	140	95	517	12	629	11	4	12.8
71/B5	4	8.5	11	130	160	110	488	12	600	14	5	16.3
80/B5	4	5	13	165	200	130	517	12	629	19	6	21.8
90/B5	4	5	13	165	200	130	517	12	629	24	8	27.3
100/B5	4	5.5	15	215	250	180	510	12	622	28	8	31.3
112/B5	4	5.5	15	215	250	180	510	12	622	28	8	31.3

KN475.05  
KN476.05

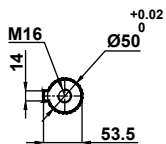
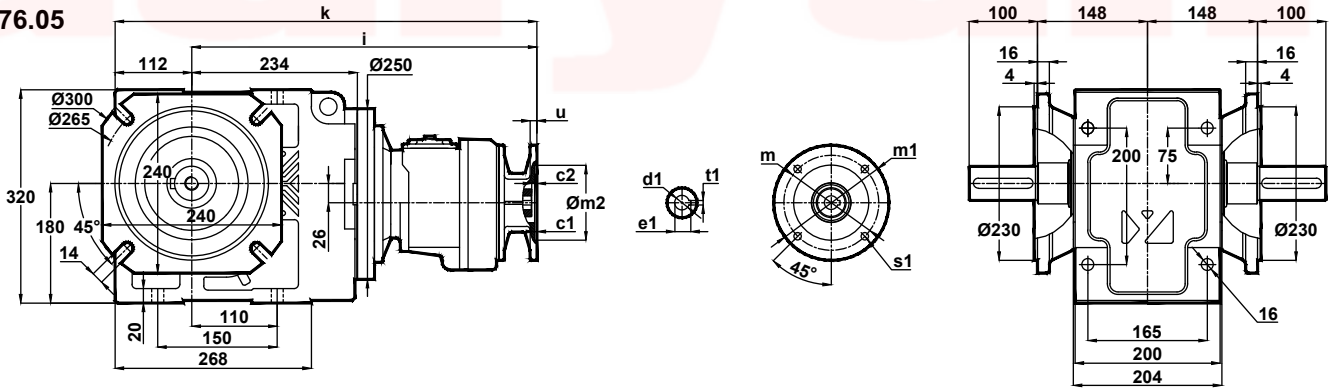

	c1	c2	s1	m	m1	m2	i1	u	k	d1	t1	e1
63/B5	4	8	9	115	140	95	517	12	629	11	4	12.8
71/B5	4	8.5	11	130	160	110	488	12	600	14	5	16.3
80/B5	4	5	13	165	200	130	517	12	629	19	6	21.8
90/B5	4	5	13	165	200	130	517	12	629	24	8	27.3
100/B5	4	5.5	15	215	250	180	510	12	622	28	8	31.3
112/B5	4	5.5	15	215	250	180	510	12	622	28	8	31.3



# Ölçü Sayfaları Dimension Pages Abmessungsseiten



-Mil ucu çekirme deliği DIN 332 sayfa 2 / Tapped center hole to DIN 332, sheet 2 / Zentrierung mit gewinde DIN 332, Blatt 2

KN475.08  
KN476.08

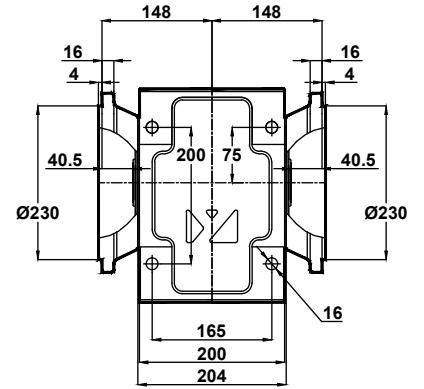
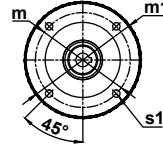
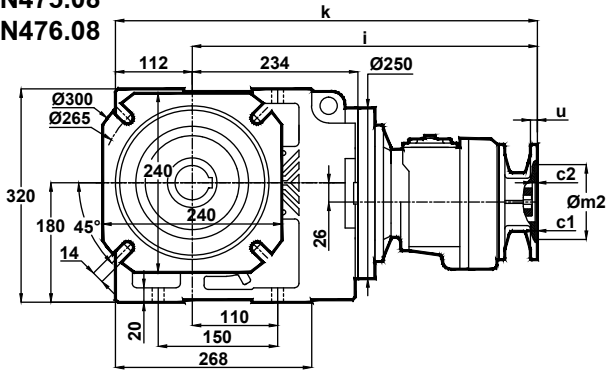

Std.

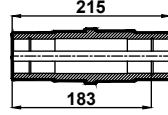
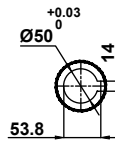

Ops.

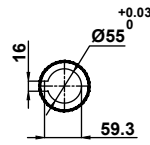

	c1	c2	s1	m	m1	m2	i1	u	k	d1	t1	e1
63/B5	4	8	9	115	140	95	517	12	629	11	4	12.8
71/B5	4	8.5	11	130	160	110	488	12	600	14	5	16.3
80/B5	4	5	13	165	200	130	517	12	629	19	6	21.8
90/B5	4	5	13	165	200	130	517	12	629	24	8	27.3
100/B5	4	5.5	15	215	250	180	510	12	622	28	8	31.3
112/B5	4	5.5	15	215	250	180	510	12	622	28	8	31.3



# Ölçü Sayfaları

## Dimension Pages

### Abmessungsseiten



-Mil ucu çektirme deliği DIN 332 sayfa 2 / Tapped center hole to DIN 332, sheet 2 / Zentrierung mit gewinde DIN 332, Blatt 2

#### KN573.00

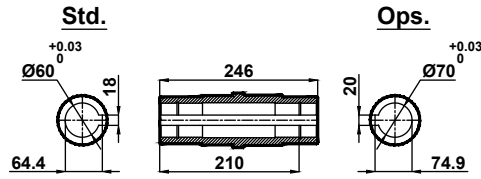
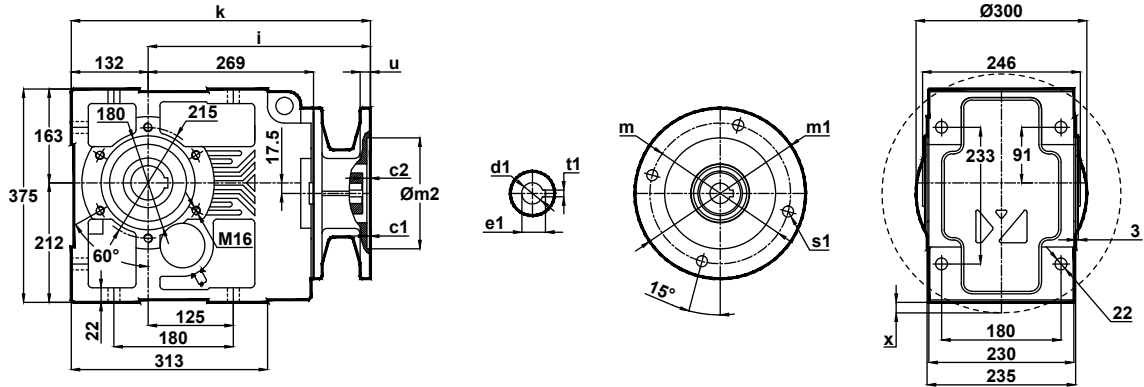

x: Motor Ayak bağlantı yüzeyinin altında ise  
x: If Motor is lower then foot mounting plane  
x: Wenn motor ist niedriger den die Anschlußplatte

	c1	c2	s1	m	m1	m2	i1	u	k	d1	t1	e1	x
100/B5	4.5	20	15	215	250	180	73	15	546	28	8	31.3	-
112/B5	4.5	20	15	215	250	180	73	15	546	28	8	31.3	-
132/B5	4.5	9	15	265	300	230	94	15	567	38	10	41.3	-
160/B5	5.5	10	19	300	350	250	169	18	643	42	12	45.3	-
180/B5	5.5	10	19	300	350	250	169	18	643	48	14	51.8	-
200/B5	5.5	10	19	350	400	300	189	22	663	55	16	59.3	5.5

#### KN573.01

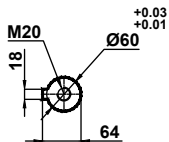
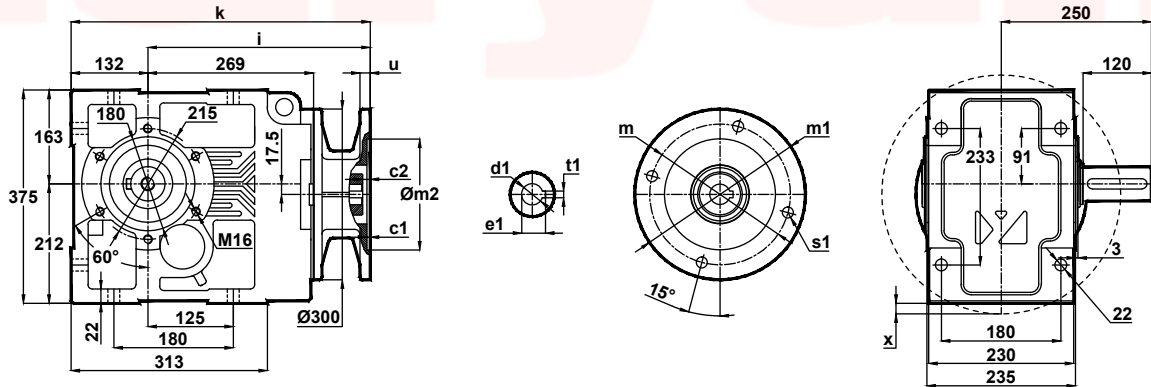

x: Motor Ayak bağlantı yüzeyinin altında ise  
x: If Motor is lower then foot mounting plane  
x: Wenn motor ist niedriger den die Anschlußplatte

	c1	c2	s1	m	m1	m2	i1	u	k	d1	t1	e1	x
100/B5	4.5	20	15	215	250	180	73	15	546	28	8	31.3	-
112/B5	4.5	20	15	215	250	180	73	15	546	28	8	31.3	-
132/B5	4.5	9	15	265	300	230	94	15	567	38	10	41.3	-
160/B5	5.5	10	19	300	350	250	169	18	643	42	12	45.3	-
180/B5	5.5	10	19	300	350	250	169	18	643	48	14	51.8	-
200/B5	5.5	10	19	350	400	300	189	22	663	55	16	59.3	5.5





# Ölçü Sayfaları Dimension Pages Abmessungsseiten



-Mil ucu çektirme deliği DIN 332 sayfa 2 / Tapped center hole to DIN 332, sheet 2 / Zentrierung mit gewinde DIN 332, Blatt 2

## KN573.02

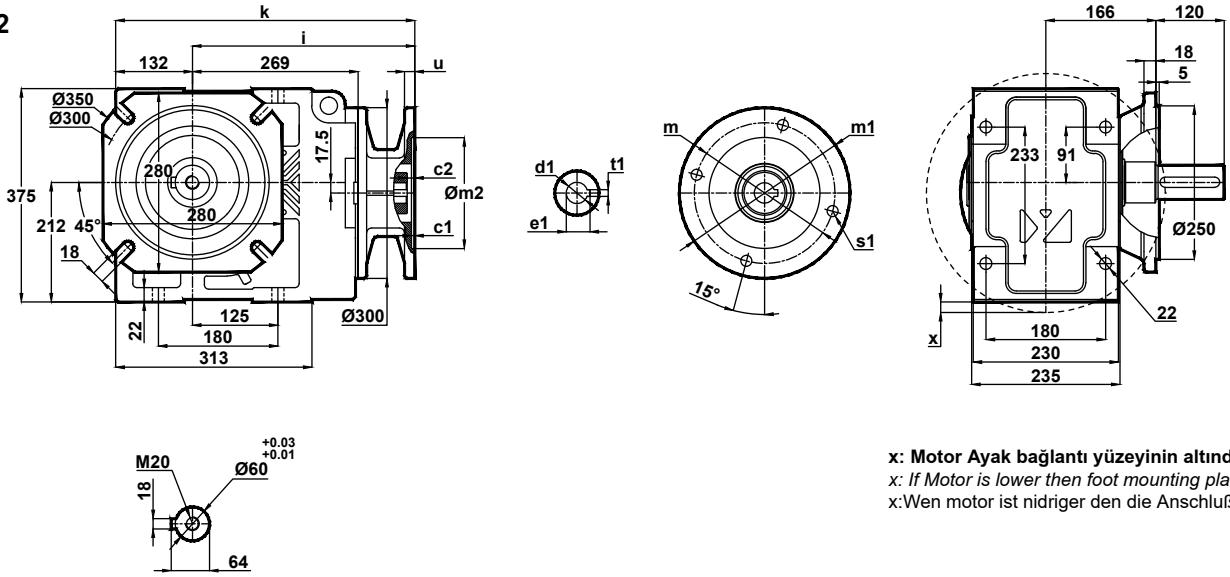

x: Motor Ayak bağlantı yüzeyinin altında ise  
x: If Motor is lower then foot mounting plane  
x: Wenn motor ist niedriger den die Anschlussplatte

	c1	c2	s1	m	m1	m2	i1	u	k	d1	t1	e1	x
100/B5	4.5	20	15	215	250	180	73	15	546	28	8	31.3	-
112/B5	4.5	20	15	215	250	180	73	15	546	28	8	31.3	-
132/B5	4.5	9	15	265	300	230	94	15	567	38	10	41.3	-
160/B5	5.5	10	19	300	350	250	169	18	643	42	12	45.3	-
180/B5	5.5	10	19	300	350	250	169	18	643	48	14	51.8	-
200/B5	5.5	10	19	350	400	300	189	22	663	55	16	59.3	5.5

## KN573.03

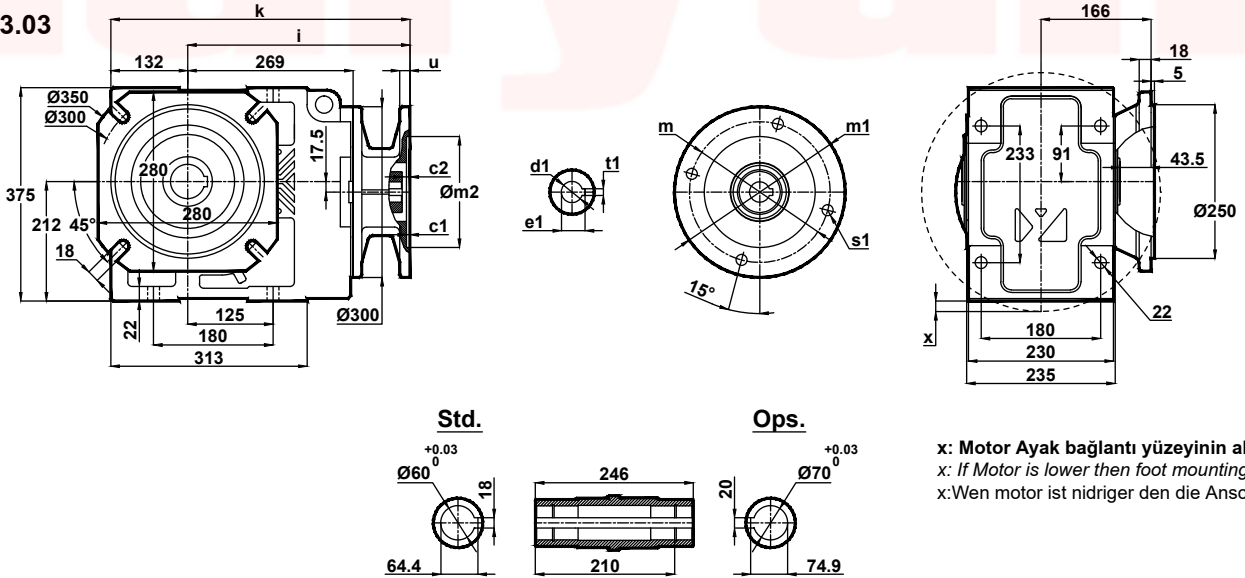

x: Motor Ayak bağlantı yüzeyinin altında ise  
x: If Motor is lower then foot mounting plane  
x: Wenn motor ist niedriger den die Anschlussplatte

	c1	c2	s1	m	m1	m2	i1	u	k	d1	t1	e1	x
100/B5	4.5	20	15	215	250	180	73	15	546	28	8	31.3	-
112/B5	4.5	20	15	215	250	180	73	15	546	28	8	31.3	-
132/B5	4.5	9	15	265	300	230	94	15	567	38	10	41.3	-
160/B5	5.5	10	19	300	350	250	169	18	643	42	12	45.3	-
180/B5	5.5	10	19	300	350	250	169	18	643	48	14	51.8	-
200/B5	5.5	10	19	350	400	300	189	22	663	55	16	59.3	5.5



# Ölçü Sayfaları Dimension Pages Abmessungsseiten



-Mil ucu çektirme deliği DIN 332 sayfa 2 / Tapped center hole to DIN 332, sheet 2 / Zentrierung mit gewinde DIN 332, Blatt 2

## KN573.04

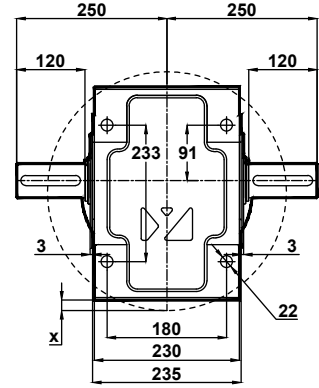
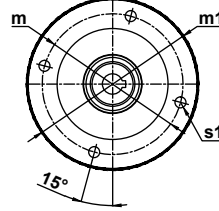
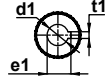
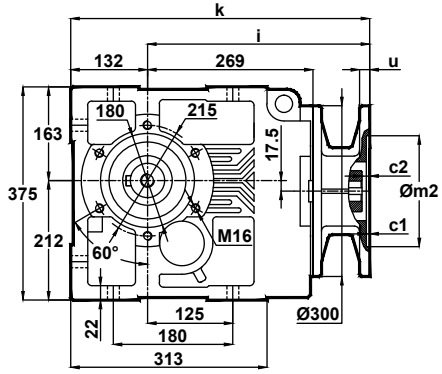

x: Motor ayak bağlantı yüzeyinin altında ise  
x: If Motor is lower then foot mounting plane  
x: Wenn motor ist niedriger den die Anschlußplatte

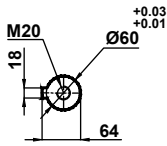

	c1	c2	s1	m	m1	m2	i1	u	k	d1	t1	e1	x
100/B5	4.5	20	15	215	250	180	73	15	546	28	8	31.3	-
112/B5	4.5	20	15	215	250	180	73	15	546	28	8	31.3	-
132/B5	4.5	9	15	265	300	230	94	15	567	38	10	41.3	-
160/B5	5.5	10	19	300	350	250	169	18	643	42	12	45.3	-
180/B5	5.5	10	19	300	350	250	169	18	643	48	14	51.8	-
200/B5	5.5	10	19	350	400	300	189	22	663	55	16	59.3	5.5

## KN573.05

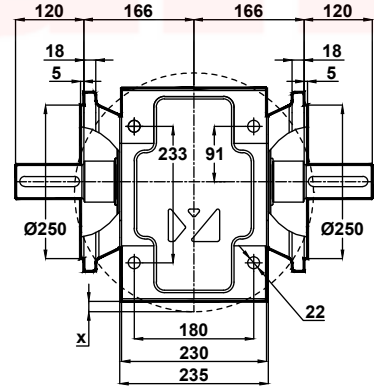
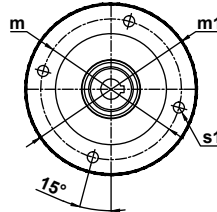
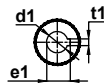
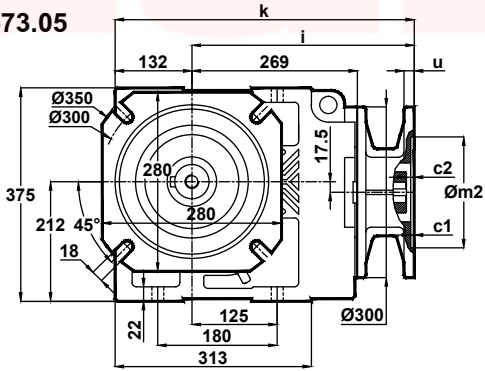

x: Motor ayak bağlantı yüzeyinin altında ise  
x: If Motor is lower then foot mounting plane  
x: Wenn motor ist niedriger den die Anschlußplatte

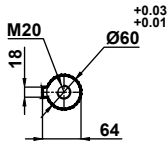

	c1	c2	s1	m	m1	m2	i1	u	k	d1	t1	e1	x
100/B5	4.5	20	15	215	250	180	73	15	546	28	8	31.3	-
112/B5	4.5	20	15	215	250	180	73	15	546	28	8	31.3	-
132/B5	4.5	9	15	265	300	230	94	15	567	38	10	41.3	-
160/B5	5.5	10	19	300	350	250	169	18	643	42	12	45.3	-
180/B5	5.5	10	19	300	350	250	169	18	643	48	14	51.8	-
200/B5	5.5	10	19	350	400	300	189	22	663	55	16	59.3	5.5



# Ölçü Sayfaları Dimension Pages Abmessungsseiten



-Mil ucu çekirme deliği DIN 332 sayfa 2 / Tapped center hole to DIN 332, sheet 2 / Zentrierung mit gewinde DIN 332, Blatt 2

KN573.08

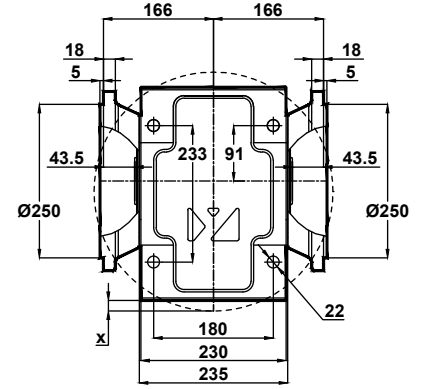
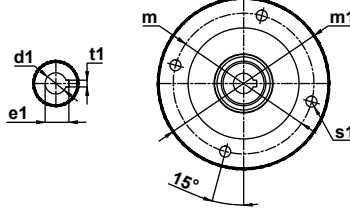
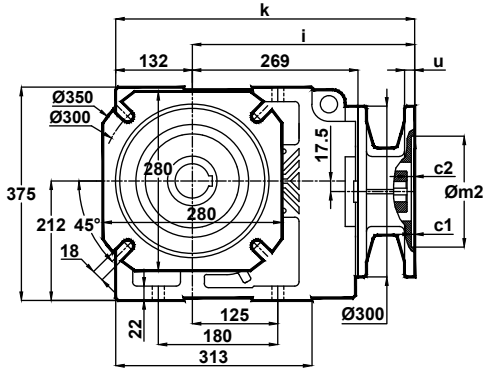

Std.

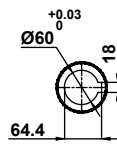

Ops.

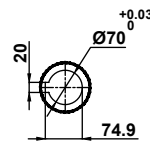

x: Motor Ayak bağlantı yüzeyinin altında ise  
x: If Motor is lower then foot mounting plane  
x: Wenn motor ist niedriger den die Anschlußplatte

	c1	c2	s1	m	m1	m2	i1	u	k	d1	t1	e1	x
100/B5	4.5	20	15	215	250	180	73	15	546	28	8	31.3	-
112/B5	4.5	20	15	215	250	180	73	15	546	28	8	31.3	-
132/B5	4.5	9	15	265	300	230	94	15	567	38	10	41.3	-
160/B5	5.5	10	19	300	350	250	169	18	643	42	12	45.3	-
180/B5	5.5	10	19	300	350	250	169	18	643	48	14	51.8	-
200/B5	5.5	10	19	350	400	300	189	22	663	55	16	59.3	5.5



# Ölçü Sayfaları

## Dimension Pages

### Abmessungsseiten



-Mil ucu çekirme deliği DIN 332 sayfa 2 / Tapped center hole to DIN 332, sheet 2 / Zentrierung mit gewinde DIN 332, Blatt 2

#### KN574.00

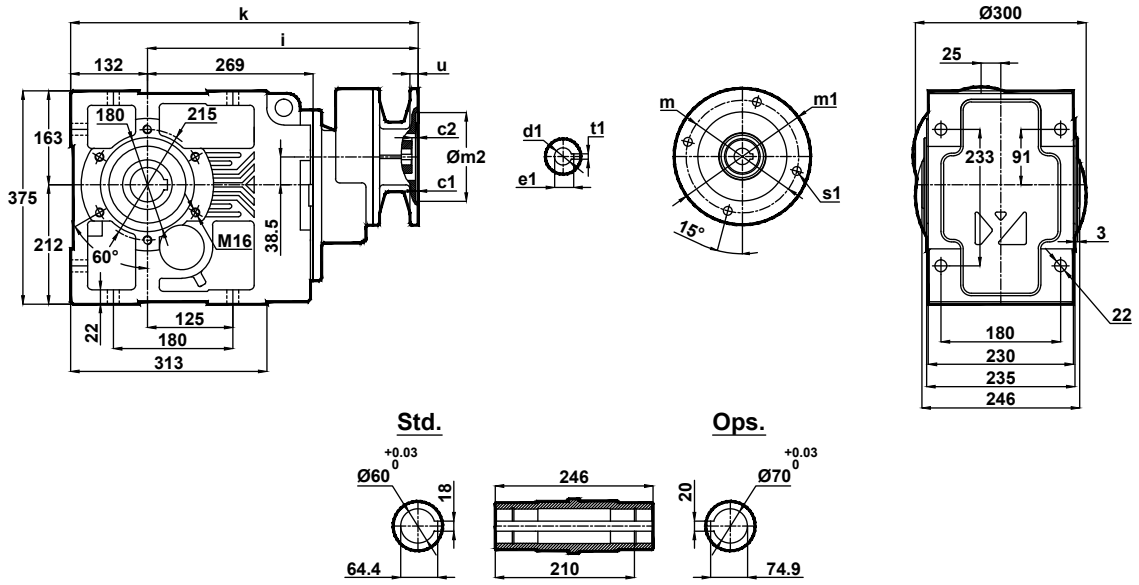

	c1	c2	s1	m	m1	m2	i1	u	k	d1	t1	e1
71/B5	4	9	11	130	160	110	422	12	469	14	5	16.3
80/B5	4	9	13	165	200	130	422	12	469	19	6	21.8
90/B5	4	9	13	165	200	130	422	12	469	24	8	27.3
100/B5	4.5	9	15	215	250	180	439	15	489	28	8	31.3
112/B5	4.5	9	15	215	250	180	439	15	489	28	8	31.3
132/B5	4.5	7	15	265	300	230	459	15	506	38	10	41.3

#### KN574.01

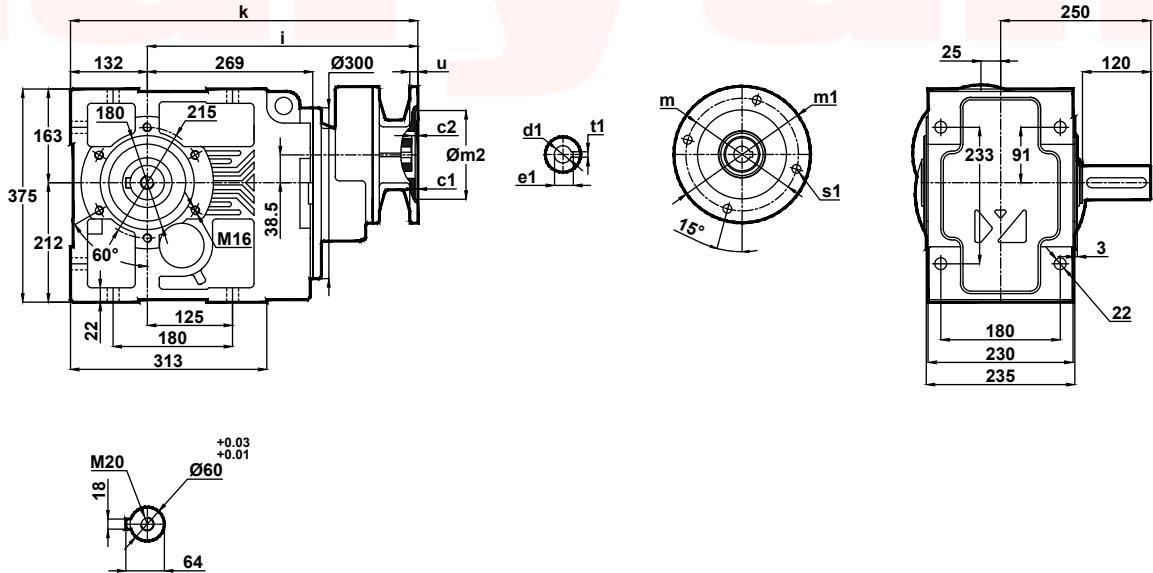

	c1	c2	s1	m	m1	m2	i1	u	k	d1	t1	e1
71/B5	4	9	11	130	160	110	422	12	469	14	5	16.3
80/B5	4	9	13	165	200	130	422	12	469	19	6	21.8
90/B5	4	9	13	165	200	130	422	12	469	24	8	27.3
100/B5	4.5	9	15	215	250	180	439	15	489	28	8	31.3
112/B5	4.5	9	15	215	250	180	439	15	489	28	8	31.3
132/B5	4.5	7	15	265	300	230	459	15	506	38	10	41.3



# Ölçü Sayfaları Dimension Pages Abmessungsseiten



-Mil ucu çekirme deliği DIN 332 sayfa 2 / Tapped center hole to DIN 332, sheet 2 / Zentrierung mit gewinde DIN 332, Blatt 2

## KN574.02

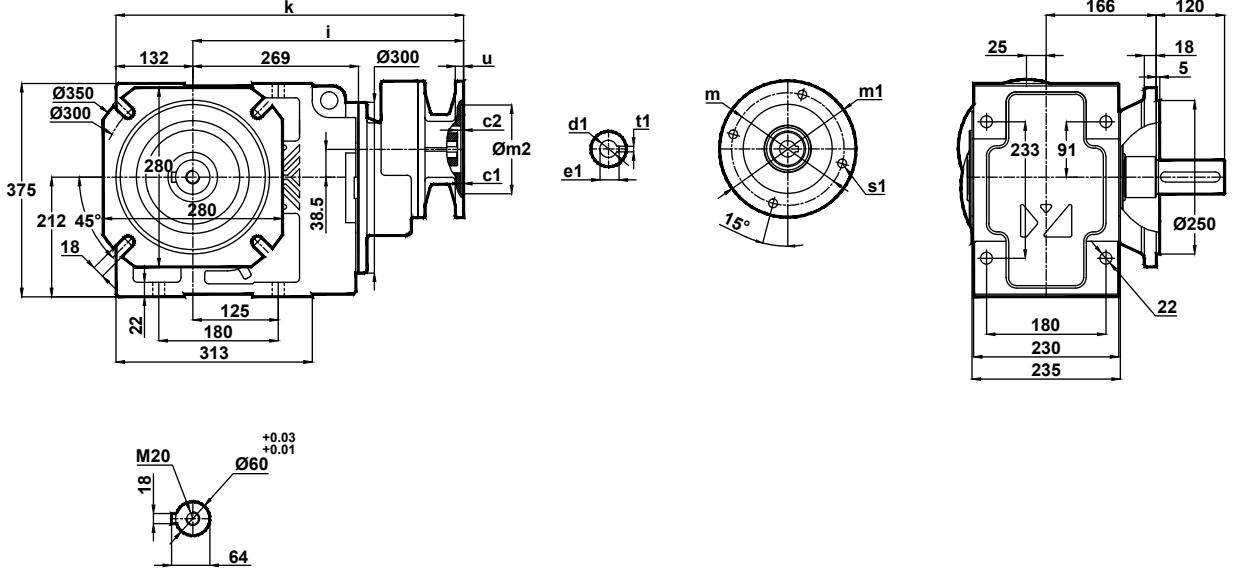

	c1	c2	s1	m	m1	m2	i1	u	k	d1	t1	e1
71/B5	4	9	11	130	160	110	422	12	469	14	5	16.3
80/B5	4	9	13	165	200	130	422	12	469	19	6	21.8
90/B5	4	9	13	165	200	130	422	12	469	24	8	27.3
100/B5	4.5	9	15	215	250	180	439	15	489	28	8	31.3
112/B5	4.5	9	15	215	250	180	439	15	489	28	8	31.3
132/B5	4.5	7	15	265	300	230	459	15	506	38	10	41.3

## KN574.03

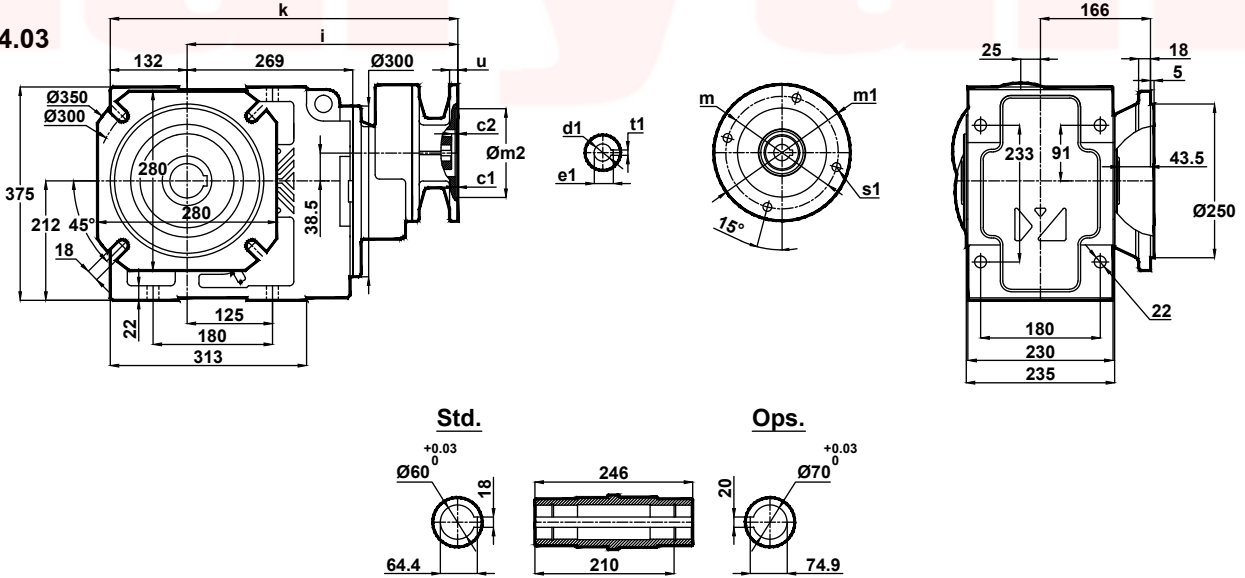

	c1	c2	s1	m	m1	m2	i1	u	k	d1	t1	e1
71/B5	4	9	11	130	160	110	422	12	469	14	5	16.3
80/B5	4	9	13	165	200	130	422	12	469	19	6	21.8
90/B5	4	9	13	165	200	130	422	12	469	24	8	27.3
100/B5	4.5	9	15	215	250	180	439	15	489	28	8	31.3
112/B5	4.5	9	15	215	250	180	439	15	489	28	8	31.3
132/B5	4.5	7	15	265	300	230	459	15	506	38	10	41.3



# Ölçü Sayfaları

## Dimension Pages

### Abmessungsseiten



-Mil ucu çekirme deliği DIN 332 sayfa 2 / Tapped center hole to DIN 332, sheet 2 / Zentrierung mit gewinde DIN 332, Blatt 2

#### KN574.04

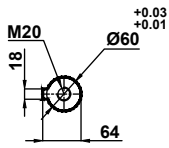
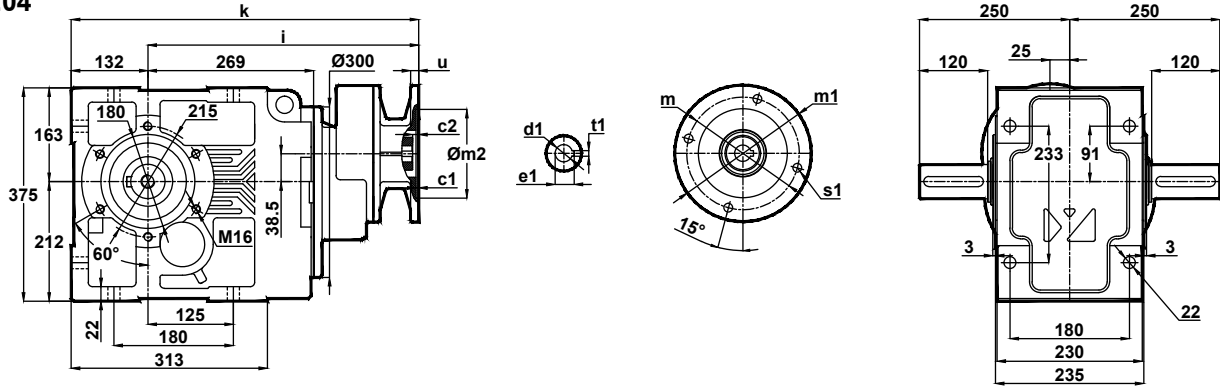

	c1	c2	s1	m	m1	m2	i1	u	k	d1	t1	e1
71/B5	4	9	11	130	160	110	422	12	469	14	5	16.3
80/B5	4	9	13	165	200	130	422	12	469	19	6	21.8
90/B5	4	9	13	165	200	130	422	12	469	24	8	27.3
100/B5	4.5	9	15	215	250	180	439	15	489	28	8	31.3
112/B5	4.5	9	15	215	250	180	439	15	489	28	8	31.3
132/B5	4.5	7	15	265	300	230	459	15	506	38	10	41.3

#### KN574.05

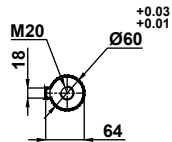
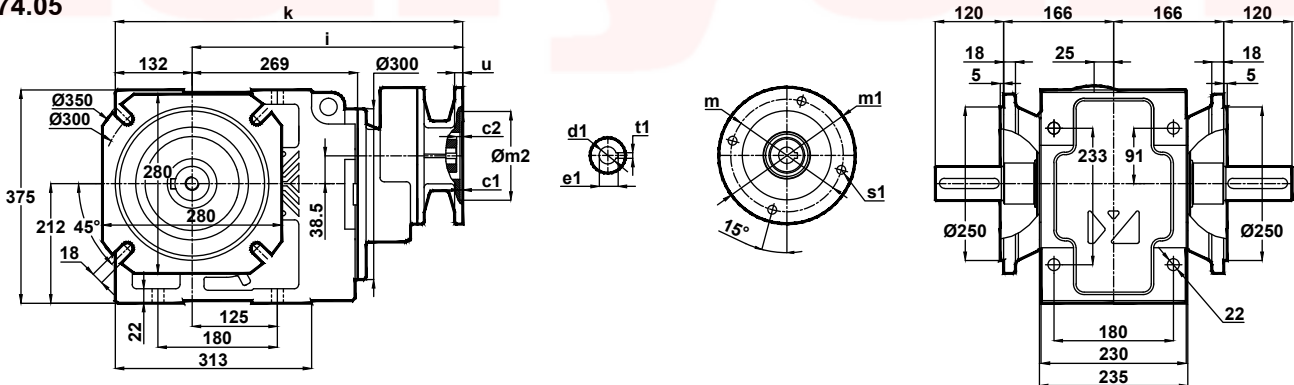

	c1	c2	s1	m	m1	m2	i1	u	k	d1	t1	e1
71/B5	4	9	11	130	160	110	422	12	469	14	5	16.3
80/B5	4	9	13	165	200	130	422	12	469	19	6	21.8
90/B5	4	9	13	165	200	130	422	12	469	24	8	27.3
100/B5	4.5	9	15	215	250	180	439	15	489	28	8	31.3
112/B5	4.5	9	15	215	250	180	439	15	489	28	8	31.3
132/B5	4.5	7	15	265	300	230	459	15	506	38	10	41.3



# Ölçü Sayfaları Dimension Pages Abmessungenseiten



-Mil ucu çekirme deliği DIN 332 sayfa 2 / Tapped center hole to DIN 332, sheet 2 / Zentrierung mit gewinde DIN 332, Blatt 2

KN574.08

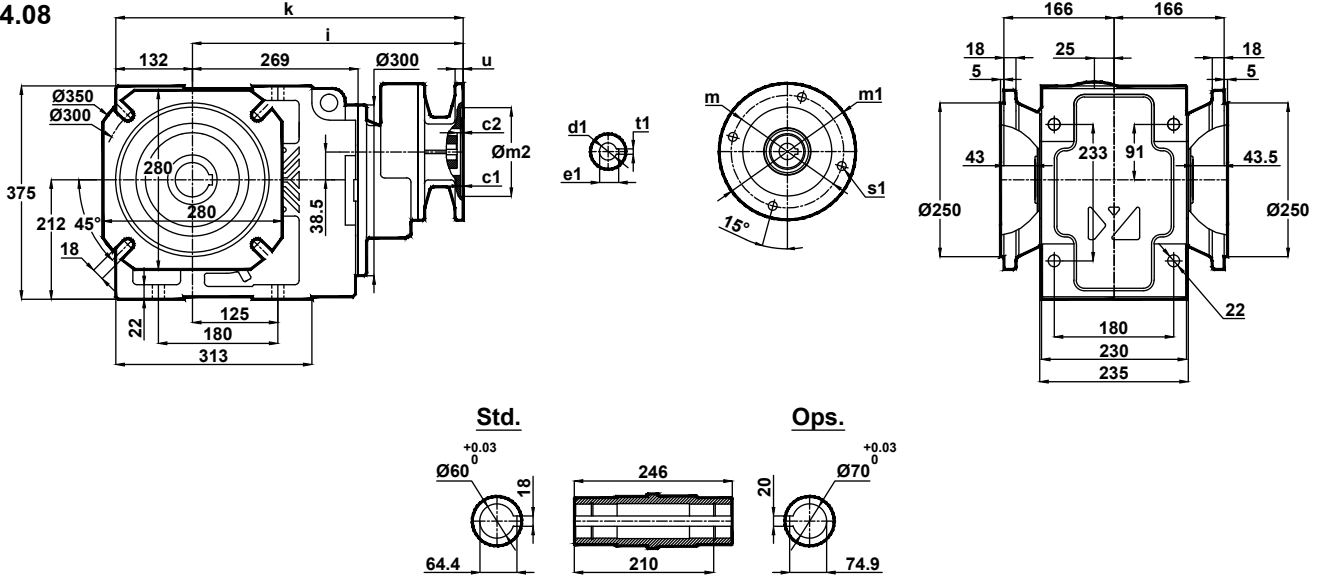

	c1	c2	s1	m	m1	m2	i1	u	k	d1	t1	e1
71/B5	4	9	11	130	160	110	422	12	469	14	5	16.3
80/B5	4	9	13	165	200	130	422	12	469	19	6	21.8
90/B5	4	9	13	165	200	130	422	12	469	24	8	27.3
100/B5	4.5	9	15	215	250	180	439	15	489	28	8	31.3
112/B5	4.5	9	15	215	250	180	439	15	489	28	8	31.3
132/B5	4.5	7	15	265	300	230	459	15	506	38	10	41.3



# Ölçü Sayfaları

## Dimension Pages

### Abmessungsseiten



-Mil ucu çekirme deliği DIN 332 sayfa 2 / Tapped center hole to DIN 332, sheet 2 / Zentrierung mit gewinde DIN 332, Blatt 2

KN575.00  
KN576.00

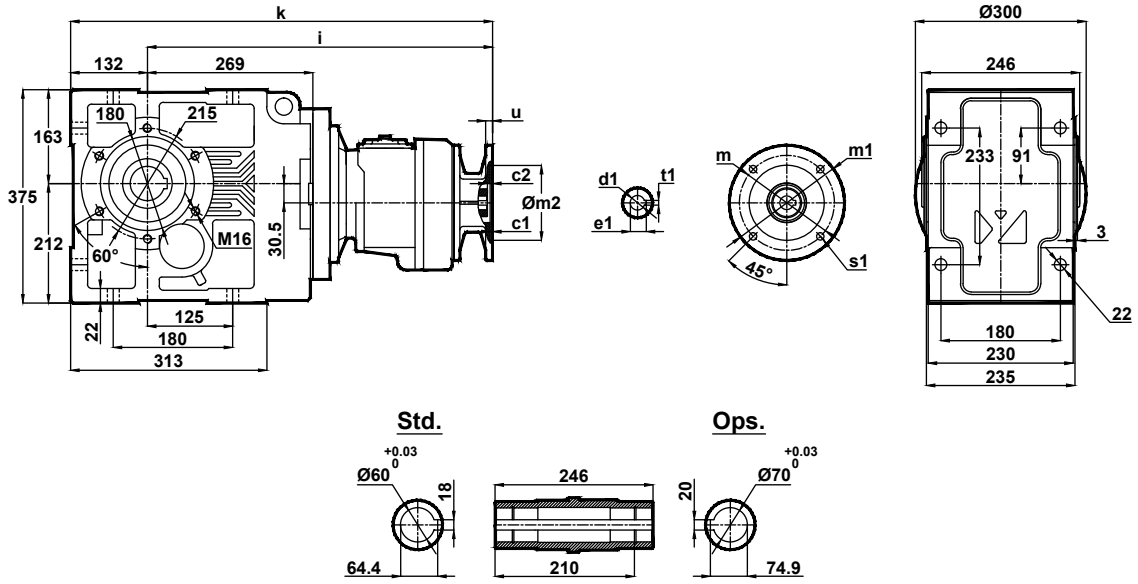

	c1	c2	s1	m	m1	m2	i1	u	k	d1	t1	e1
63/B5	4	8	9	115	140	95	637	12	684	11	4	12.8
71/B5	4	8.5	11	130	160	110	637	12	655	14	5	16.3
80/B5	4	5	13	165	200	130	637	12	684	19	6	21.8
90/B5	4	5	13	165	200	130	654	12	684	24	8	27.3
100/B5	4	5.5	15	215	250	180	654	12	677	28	8	31.3
112/B5	4	5.5	15	215	250	180	674	12	677	28	8	31.3

KN575.01  
KN576.01

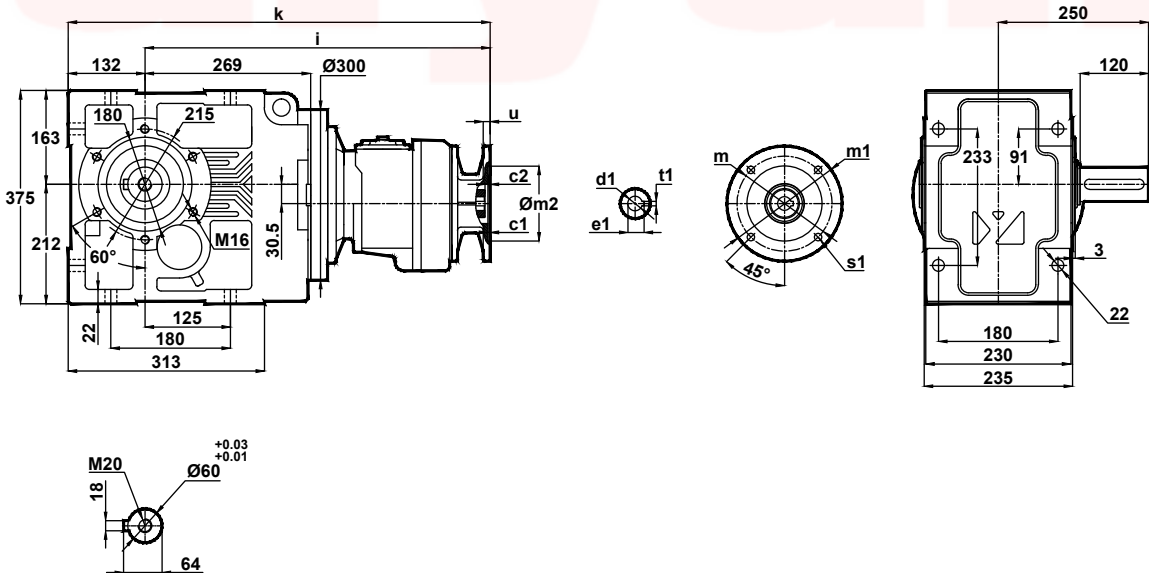

	c1	c2	s1	m	m1	m2	i1	u	k	d1	t1	e1
63/B5	4	8	9	115	140	95	637	12	684	11	4	12.8
71/B5	4	8.5	11	130	160	110	637	12	655	14	5	16.3
80/B5	4	5	13	165	200	130	637	12	684	19	6	21.8
90/B5	4	5	13	165	200	130	654	12	684	24	8	27.3
100/B5	4	5.5	15	215	250	180	654	12	677	28	8	31.3
112/B5	4	5.5	15	215	250	180	674	12	677	28	8	31.3





# Ölçü Sayfaları

## Dimension Pages

### Abmessungsseiten



-Mil ucu çekirme deliği DIN 332 sayfa 2 / Tapped center hole to DIN 332, sheet 2 / Zentrierung mit gewinde DIN 332, Blatt 2

KN575.02  
KN576.02

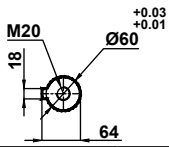
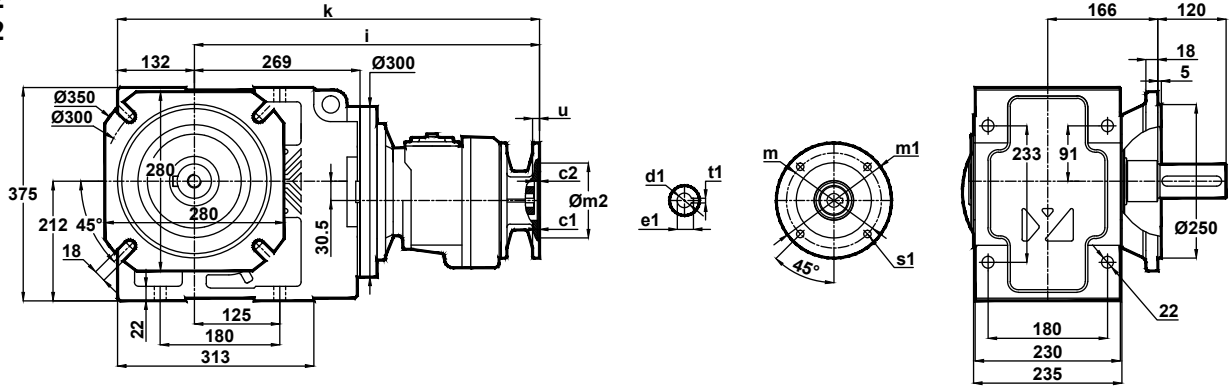

	c1	c2	s1	m	m1	m2	i1	u	k	d1	t1	e1
63/B5	4	8	9	115	140	95	637	12	684	11	4	12.8
71/B5	4	8.5	11	130	160	110	637	12	655	14	5	16.3
80/B5	4	5	13	165	200	130	637	12	684	19	6	21.8
90/B5	4	5	13	165	200	130	654	12	684	24	8	27.3
100/B5	4	5.5	15	215	250	180	654	12	677	28	8	31.3
112/B5	4	5.5	15	215	250	180	674	12	677	28	8	31.3

KN575.03  
KN576.03

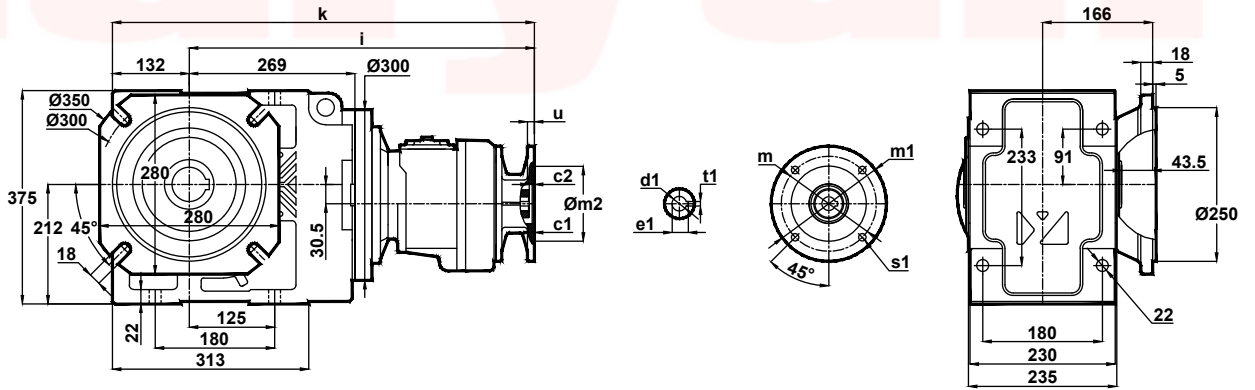

Std.

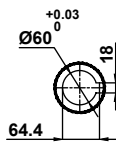

Ops.

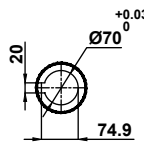

	c1	c2	s1	m	m1	m2	i1	u	k	d1	t1	e1
63/B5	4	8	9	115	140	95	637	12	684	11	4	12.8
71/B5	4	8.5	11	130	160	110	637	12	655	14	5	16.3
80/B5	4	5	13	165	200	130	637	12	684	19	6	21.8
90/B5	4	5	13	165	200	130	654	12	684	24	8	27.3
100/B5	4	5.5	15	215	250	180	654	12	677	28	8	31.3
112/B5	4	5.5	15	215	250	180	674	12	677	28	8	31.3



# Ölçü Sayfaları

## Dimension Pages

### Abmessungsseiten



-Mil ucu çekirme deliği DIN 332 sayfa 2 / Tapped center hole to DIN 332, sheet 2 / Zentrierung mit gewinde DIN 332, Blatt 2

KN575.04  
KN576.04

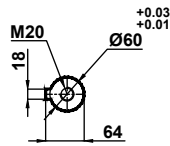
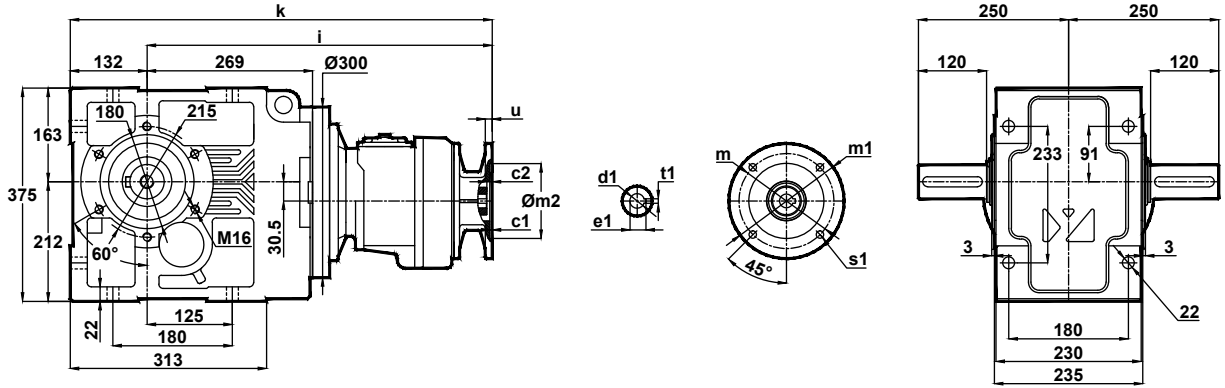

	c1	c2	s1	m	m1	m2	i1	u	k	d1	t1	e1
63/B5	4	8	9	115	140	95	637	12	684	11	4	12.8
71/B5	4	8.5	11	130	160	110	637	12	655	14	5	16.3
80/B5	4	5	13	165	200	130	637	12	684	19	6	21.8
90/B5	4	5	13	165	200	130	654	12	684	24	8	27.3
100/B5	4	5.5	15	215	250	180	654	12	677	28	8	31.3
112/B5	4	5.5	15	215	250	180	674	12	677	28	8	31.3

KN575.05  
KN576.05

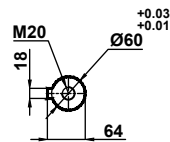
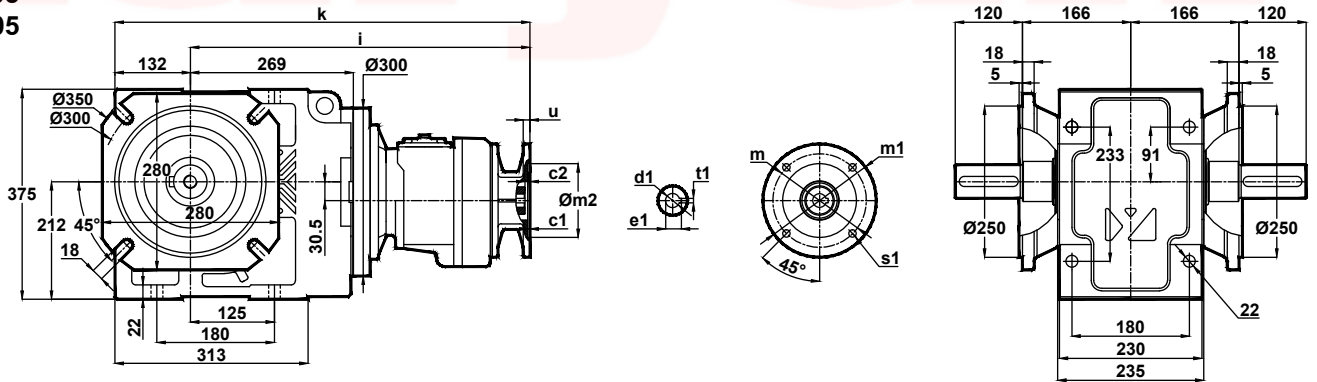

	c1	c2	s1	m	m1	m2	i1	u	k	d1	t1	e1
63/B5	4	8	9	115	140	95	637	12	684	11	4	12.8
71/B5	4	8.5	11	130	160	110	637	12	655	14	5	16.3
80/B5	4	5	13	165	200	130	637	12	684	19	6	21.8
90/B5	4	5	13	165	200	130	654	12	684	24	8	27.3
100/B5	4	5.5	15	215	250	180	654	12	677	28	8	31.3
112/B5	4	5.5	15	215	250	180	674	12	677	28	8	31.3



# Ölçü Sayfaları Dimension Pages Abmessungenseiten



-Mil ucu çekirme deliği DIN 332 sayfa 2 / Tapped center hole to DIN 332, sheet 2 / Zentrierung mit gewinde DIN 332, Blatt 2

KN575.08  
KN576.08

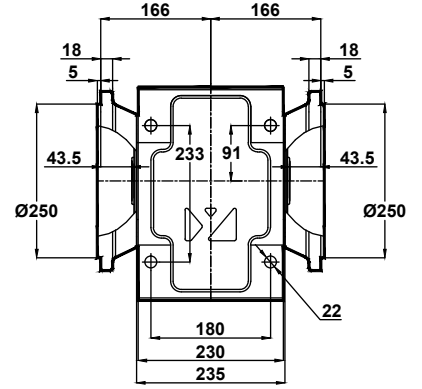
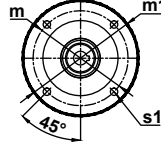
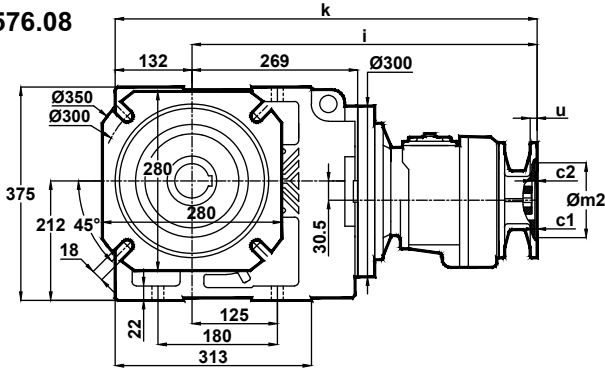

Std.

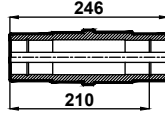
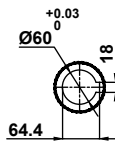

Ops.

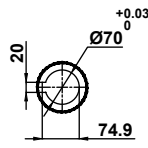

	c1	c2	s1	m	m1	m2	i1	u	k	d1	t1	e1
63/B5	4	8	9	115	140	95	637	12	684	11	4	12.8
71/B5	4	8.5	11	130	160	110	637	12	655	14	5	16.3
80/B5	4	5	13	165	200	130	637	12	684	19	6	21.8
90/B5	4	5	13	165	200	130	654	12	684	24	8	27.3
100/B5	4	5.5	15	215	250	180	654	12	677	28	8	31.3
112/B5	4	5.5	15	215	250	180	674	12	677	28	8	31.3



# Ölçü Sayfaları

## Dimension Pages

### Abmessungsseiten



-Mil ucu çekirme deliği DIN 332 sayfa 2 / Tapped center hole to DIN 332, sheet 2 / Zentrierung mit gewinde DIN 332, Blatt 2

#### KN673.00

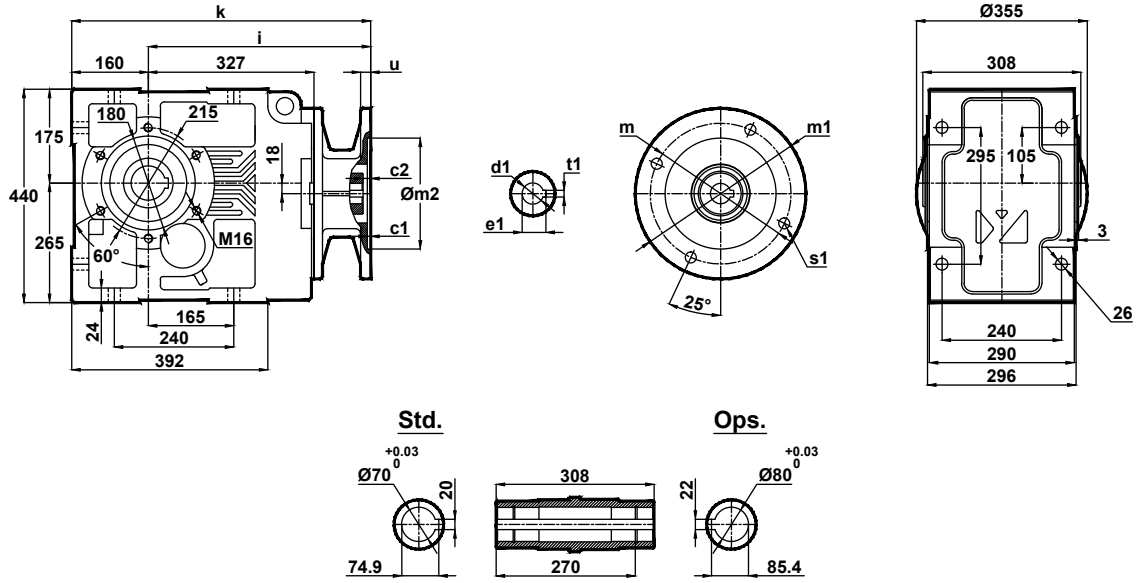

	c1	c2	s1	m	m1	m2	i1	u	k	d1	t1	e1
100/B5	4.5	14.5	15	215	250	180	69	15	624	28	8	31.3
112/B5	4.5	14.5	15	215	250	180	69	15	624	28	8	31.3
132/B5	4.5	9	15	265	300	230	84	15	639	38	10	41.3
160/B5	5.5	10	19	300	350	250	159	20	714	42	12	45.3
180/B5	5.5	10	19	300	350	250	159	20	714	48	14	51.8
200/B5	5.5	10	19	350	400	300	179	22	827	55	16	59.3
225/B5	5.5	10	19	400	450	350	232	24	880	60	18	64.4

#### KN673.01

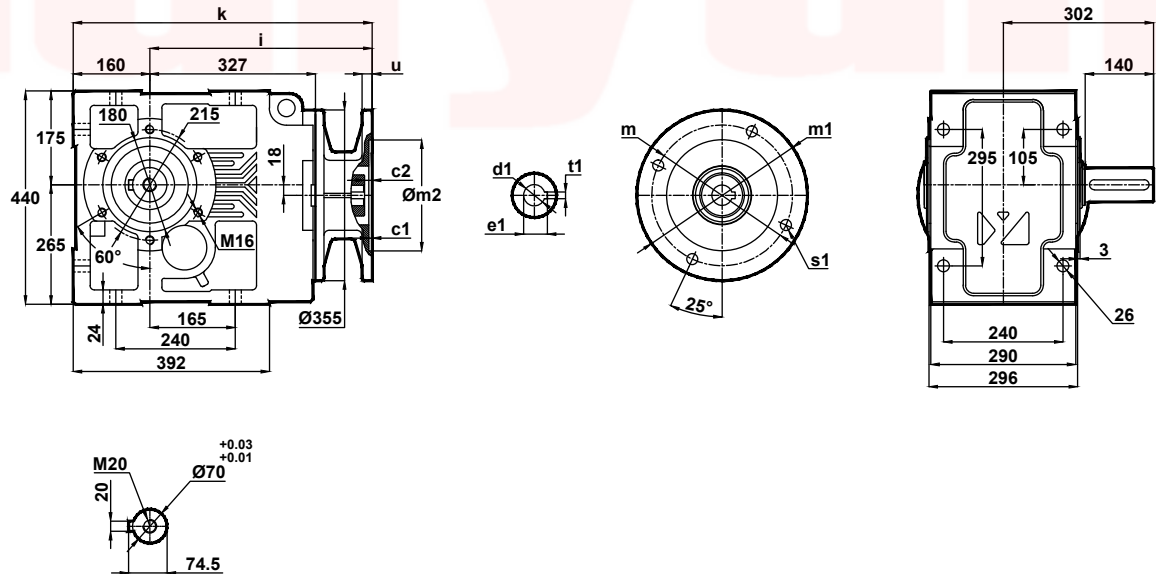

	c1	c2	s1	m	m1	m2	i1	u	k	d1	t1	e1
100/B5	4.5	14.5	15	215	250	180	69	15	624	28	8	31.3
112/B5	4.5	14.5	15	215	250	180	69	15	624	28	8	31.3
132/B5	4.5	9	15	265	300	230	84	15	639	38	10	41.3
160/B5	5.5	10	19	300	350	250	159	20	714	42	12	45.3
180/B5	5.5	10	19	300	350	250	159	20	714	48	14	51.8
200/B5	5.5	10	19	350	400	300	179	22	827	55	16	59.3
225/B5	5.5	10	19	400	450	350	232	24	880	60	18	64.4



# Ölçü Sayfaları Dimension Pages Abmessungsseiten



-Mil ucu çekirme deliği DIN 332 sayfa 2 / Tapped center hole to DIN 332, sheet 2 / Zentrierung mit gewinde DIN 332, Blatt 2

## KN673.02

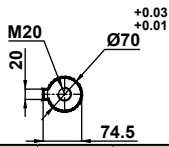
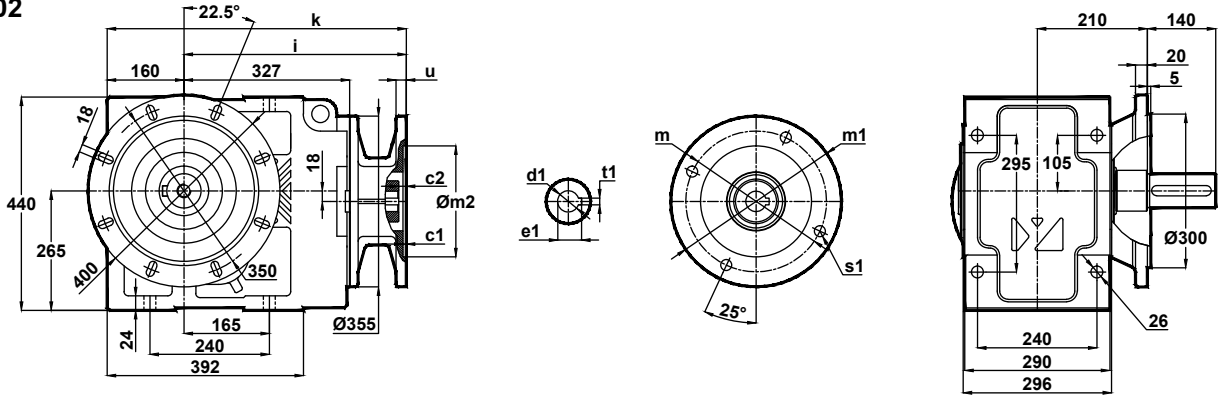

	c1	c2	s1	m	m1	m2	i1	u	k	d1	t1	e1
100/B5	4.5	14.5	15	215	250	180	69	15	624	28	8	31.3
112/B5	4.5	14.5	15	215	250	180	69	15	624	28	8	31.3
132/B5	4.5	9	15	265	300	230	84	15	639	38	10	41.3
160/B5	5.5	10	19	300	350	250	159	20	714	42	12	45.3
180/B5	5.5	10	19	300	350	250	159	20	714	48	14	51.8
200/B5	5.5	10	19	350	400	300	179	22	827	55	16	59.3
225/B5	5.5	10	19	400	450	350	232	24	880	60	18	64.4

## KN673.03

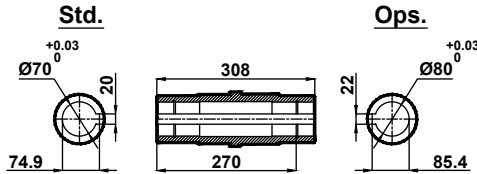
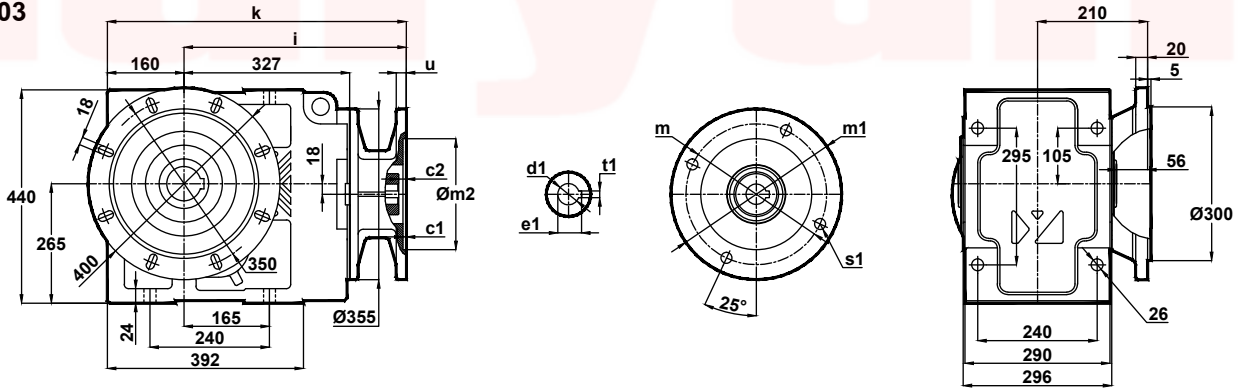

	c1	c2	s1	m	m1	m2	i1	u	k	d1	t1	e1
100/B5	4.5	14.5	15	215	250	180	69	15	624	28	8	31.3
112/B5	4.5	14.5	15	215	250	180	69	15	624	28	8	31.3
132/B5	4.5	9	15	265	300	230	84	15	639	38	10	41.3
160/B5	5.5	10	19	300	350	250	159	20	714	42	12	45.3
180/B5	5.5	10	19	300	350	250	159	20	714	48	14	51.8
200/B5	5.5	10	19	350	400	300	179	22	827	55	16	59.3
225/B5	5.5	10	19	400	450	350	232	24	880	60	18	64.4



# Ölçü Sayfaları

## Dimension Pages

### Abmessungsseiten



-Mil ucu çekirme deliği DIN 332 sayfa 2 / Tapped center hole to DIN 332, sheet 2 / Zentrierung mit gewinde DIN 332, Blatt 2

#### KN673.04

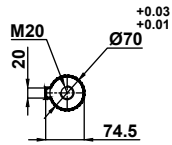
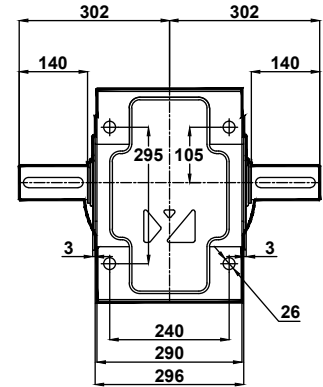
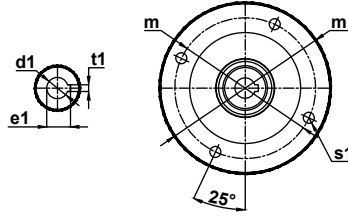
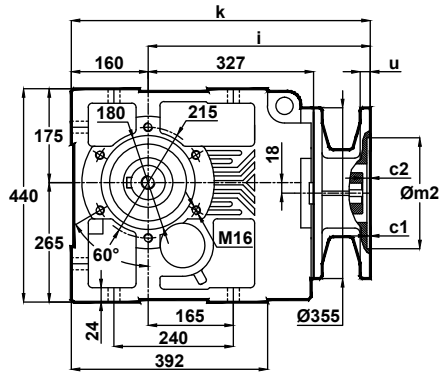

	c1	c2	s1	m	m1	m2	i1	u	k	d1	t1	e1
100/B5	4.5	14.5	15	215	250	180	69	15	624	28	8	31.3
112/B5	4.5	14.5	15	215	250	180	69	15	624	28	8	31.3
132/B5	4.5	9	15	265	300	230	84	15	639	38	10	41.3
160/B5	5.5	10	19	300	350	250	159	20	714	42	12	45.3
180/B5	5.5	10	19	300	350	250	159	20	714	48	14	51.8
200/B5	5.5	10	19	350	400	300	179	22	827	55	16	59.3
225/B5	5.5	10	19	400	450	350	232	24	880	60	18	64.4

#### KN673.05

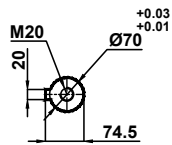
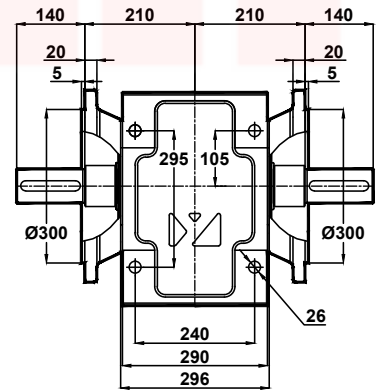
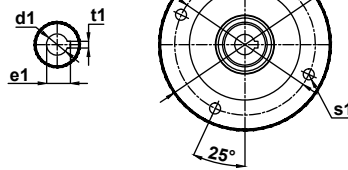
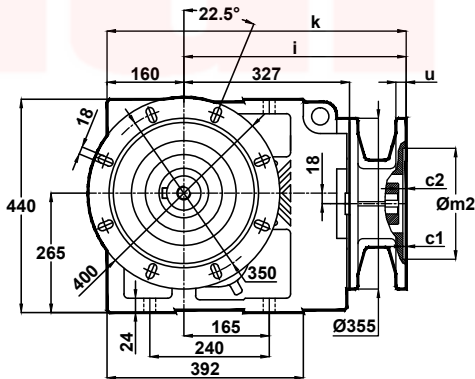

	c1	c2	s1	m	m1	m2	i1	u	k	d1	t1	e1
100/B5	4.5	14.5	15	215	250	180	69	15	624	28	8	31.3
112/B5	4.5	14.5	15	215	250	180	69	15	624	28	8	31.3
132/B5	4.5	9	15	265	300	230	84	15	639	38	10	41.3
160/B5	5.5	10	19	300	350	250	159	20	714	42	12	45.3
180/B5	5.5	10	19	300	350	250	159	20	714	48	14	51.8
200/B5	5.5	10	19	350	400	300	179	22	827	55	16	59.3
225/B5	5.5	10	19	400	450	350	232	24	880	60	18	64.4



# Ölçü Sayfaları Dimension Pages Abmessungenseiten



-Mil ucu çekirme deliği DIN 332 sayfa 2 / Tapped center hole to DIN 332, sheet 2 / Zentrierung mit gewinde DIN 332, Blatt 2

KN673.08

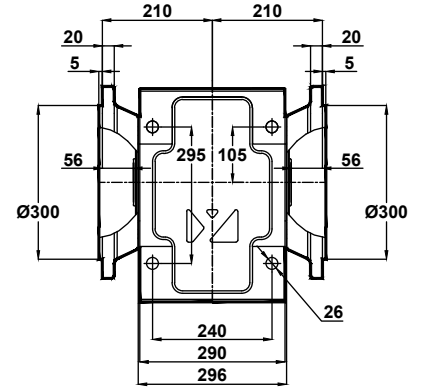
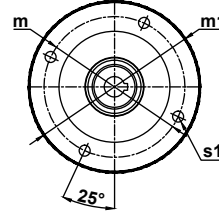
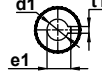
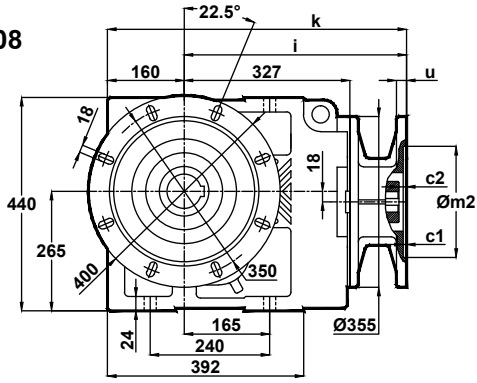

Std.

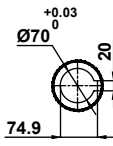

Ops.

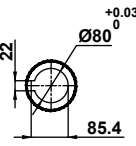
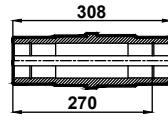

	c1	c2	s1	m	m1	m2	i1	u	k	d1	t1	e1
100/B5	4.5	14.5	15	215	250	180	69	15	624	28	8	31.3
112/B5	4.5	14.5	15	215	250	180	69	15	624	28	8	31.3
132/B5	4.5	9	15	265	300	230	84	15	639	38	10	41.3
160/B5	5.5	10	19	300	350	250	159	20	714	42	12	45.3
180/B5	5.5	10	19	300	350	250	159	20	714	48	14	51.8
200/B5	5.5	10	19	350	400	300	179	22	827	55	16	59.3
225/B5	5.5	10	19	400	450	350	232	24	880	60	18	64.4



# Ölçü Sayfaları

## Dimension Pages

### Abmessungsseiten



-Mil ucu çekirme deliği DIN 332 sayfa 2 / Tapped center hole to DIN 332, sheet 2 / Zentrierung mit gewinde DIN 332, Blatt 2

#### KN674.00

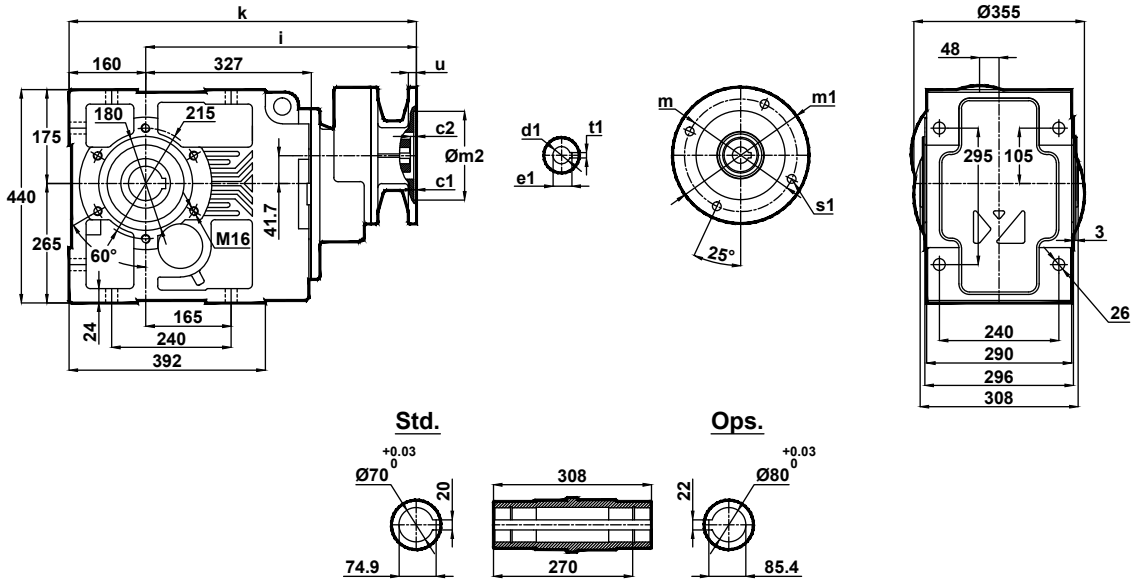

	c1	c2	s1	m	m1	m2	i1	u	k	d1	t1	e1
80/B5	4	5	12	162	200	130	486	12	576	19	6	21.8
90/B5	4	5	13	165	200	130	486	12	576	24	8	27.3
100/B5	4.5	9	15	215	250	180	504	15	594	28	8	31.3
112/B5	4.5	9	15	215	250	180	504	15	594	28	8	31.3
132/B5	4.5	6	15	265	300	230	523	15	613	38	10	41.3
160/B5	5.5	10	19	300	350	250	602	20	692	42	12	45.3
180/B5	5.5	10	19	300	350	250	602	20	692	48	14	51.8

#### KN674.01

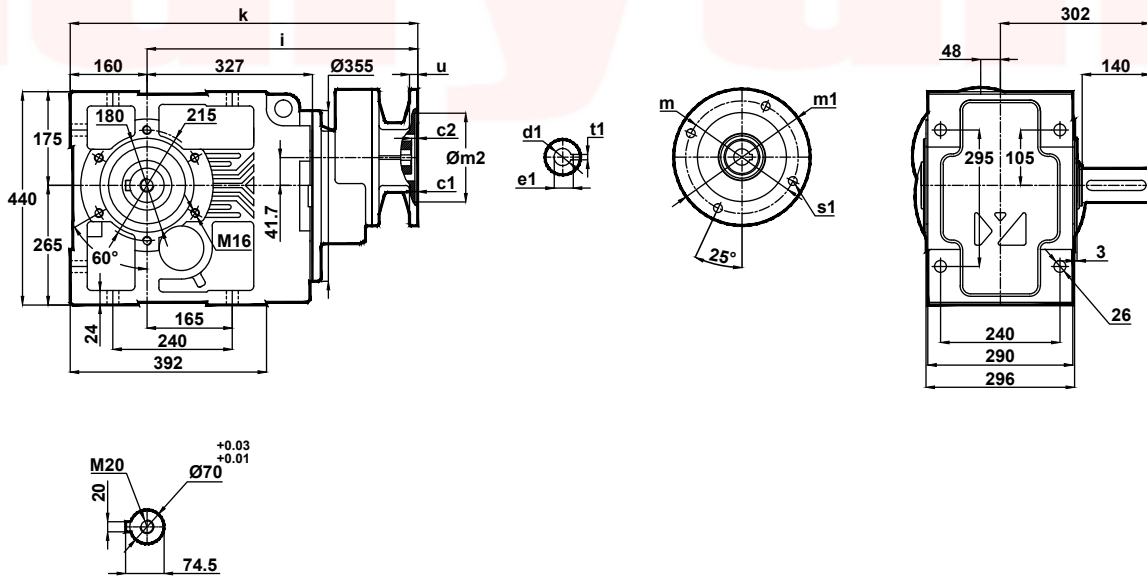

	c1	c2	s1	m	m1	m2	i1	u	k	d1	t1	e1
80/B5	4	5	12	162	200	130	486	12	576	19	6	21.8
90/B5	4	5	13	165	200	130	486	12	576	24	8	27.3
100/B5	4.5	9	15	215	250	180	504	15	594	28	8	31.3
112/B5	4.5	9	15	215	250	180	504	15	594	28	8	31.3
132/B5	4.5	6	15	265	300	230	523	15	613	38	10	41.3
160/B5	5.5	10	19	300	350	250	602	20	692	42	12	45.3
180/B5	5.5	10	19	300	350	250	602	20	692	48	14	51.8





# Ölçü Sayfaları

## Dimension Pages

### Abmessungsseiten



-Mil ucu çektirme deliği DIN 332 sayfa 2 / Tapped center hole to DIN 332, sheet 2 / Zentrierung mit gewinde DIN 332, Blatt 2

#### KN674.02

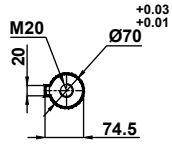
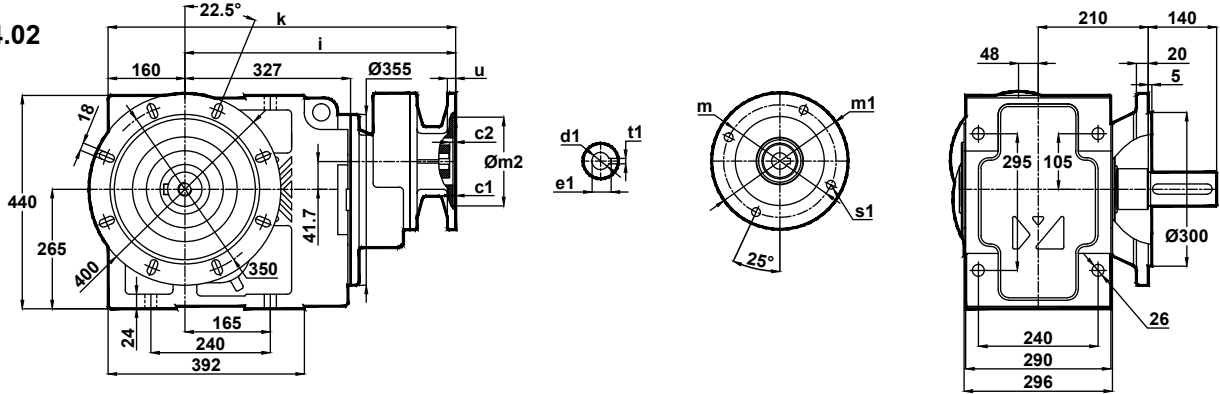

	c1	c2	s1	m	m1	m2	i1	u	k	d1	t1	e1
80/B5	4	5	12	162	200	130	486	12	576	19	6	21.8
90/B5	4	5	13	165	200	130	486	12	576	24	8	27.3
100/B5	4.5	9	15	215	250	180	504	15	594	28	8	31.3
112/B5	4.5	9	15	215	250	180	504	15	594	28	8	31.3
132/B5	4.5	6	15	265	300	230	523	15	613	38	10	41.3
160/B5	5.5	10	19	300	350	250	602	20	692	42	12	45.3
180/B5	5.5	10	19	300	350	250	602	20	692	48	14	51.8

#### KN674.03

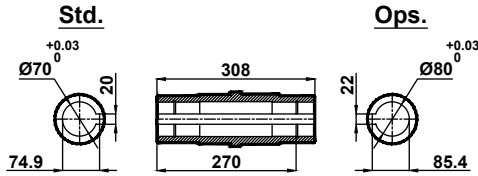
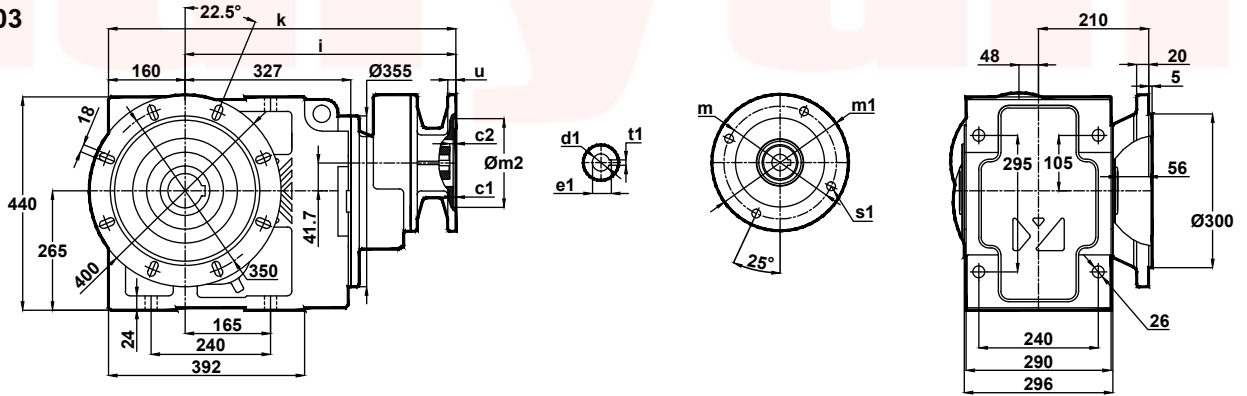

	c1	c2	s1	m	m1	m2	i1	u	k	d1	t1	e1
80/B5	4	5	12	162	200	130	486	12	576	19	6	21.8
90/B5	4	5	13	165	200	130	486	12	576	24	8	27.3
100/B5	4.5	9	15	215	250	180	504	15	594	28	8	31.3
112/B5	4.5	9	15	215	250	180	504	15	594	28	8	31.3
132/B5	4.5	6	15	265	300	230	523	15	613	38	10	41.3
160/B5	5.5	10	19	300	350	250	602	20	692	42	12	45.3
180/B5	5.5	10	19	300	350	250	602	20	692	48	14	51.8



# Ölçü Sayfaları

## Dimension Pages

### Abmessungsseiten



-Mil ucu çekirme deliği DIN 332 sayfa 2 / Tapped center hole to DIN 332, sheet 2 / Zentrierung mit gewinde DIN 332, Blatt 2

#### KN674.04

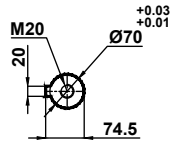
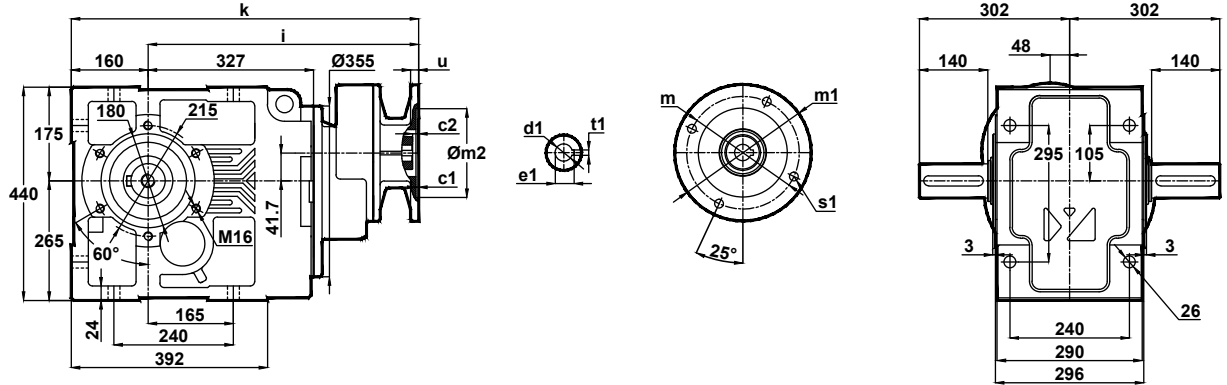

	c1	c2	s1	m	m1	m2	i1	u	k	d1	t1	e1
80/B5	4	5	12	162	200	130	486	12	576	19	6	21.8
90/B5	4	5	13	165	200	130	486	12	576	24	8	27.3
100/B5	4.5	9	15	215	250	180	504	15	594	28	8	31.3
112/B5	4.5	9	15	215	250	180	504	15	594	28	8	31.3
132/B5	4.5	6	15	265	300	230	523	15	613	38	10	41.3
160/B5	5.5	10	19	300	350	250	602	20	692	42	12	45.3
180/B5	5.5	10	19	300	350	250	602	20	692	48	14	51.8

#### KN674.05

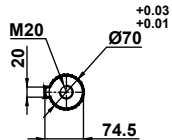
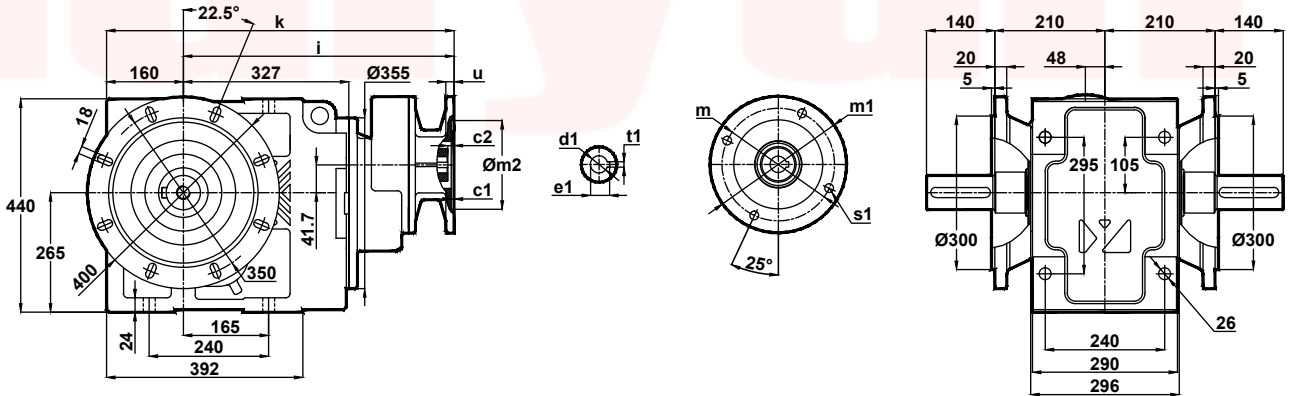

	c1	c2	s1	m	m1	m2	i1	u	k	d1	t1	e1
80/B5	4	5	12	162	200	130	486	12	576	19	6	21.8
90/B5	4	5	13	165	200	130	486	12	576	24	8	27.3
100/B5	4.5	9	15	215	250	180	504	15	594	28	8	31.3
112/B5	4.5	9	15	215	250	180	504	15	594	28	8	31.3
132/B5	4.5	6	15	265	300	230	523	15	613	38	10	41.3
160/B5	5.5	10	19	300	350	250	602	20	692	42	12	45.3
180/B5	5.5	10	19	300	350	250	602	20	692	48	14	51.8



# Ölçü Sayfaları Dimension Pages Abmessungenseiten



-Mil ucu çekirme deliği DIN 332 sayfa 2 / Tapped center hole to DIN 332, sheet 2 / Zentrierung mit gewinde DIN 332, Blatt 2

KN674.08

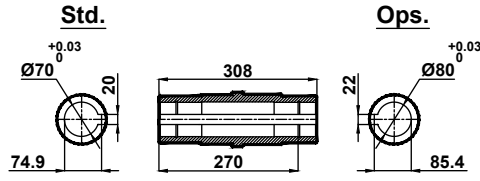
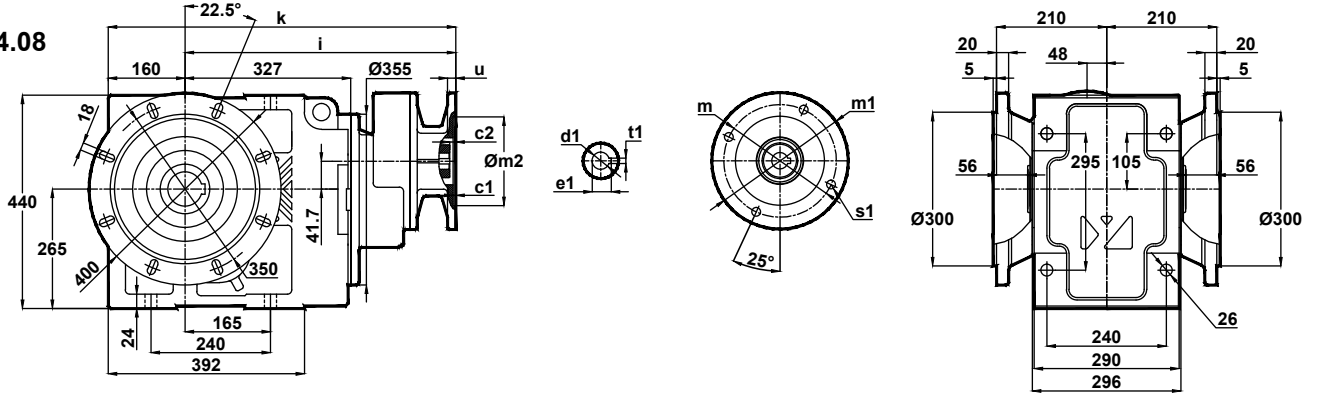

	c1	c2	s1	m	m1	m2	i1	u	k	d1	t1	e1
80/B5	4	5	12	162	200	130	486	12	576	19	6	21.8
90/B5	4	5	13	165	200	130	486	12	576	24	8	27.3
100/B5	4.5	9	15	215	250	180	504	15	594	28	8	31.3
112/B5	4.5	9	15	215	250	180	504	15	594	28	8	31.3
132/B5	4.5	6	15	265	300	230	523	15	613	38	10	41.3
160/B5	5.5	10	19	300	350	250	602	20	692	42	12	45.3
180/B5	5.5	10	19	300	350	250	602	20	692	48	14	51.8



# Ölçü Sayfaları

## Dimension Pages

### Abmessungsseiten



-Mil ucu çektirme deliği DIN 332 sayfa 2 / Tapped center hole to DIN 332, sheet 2 / Zentrierung mit gewinde DIN 332, Blatt 2

KN675.00  
KN676.00

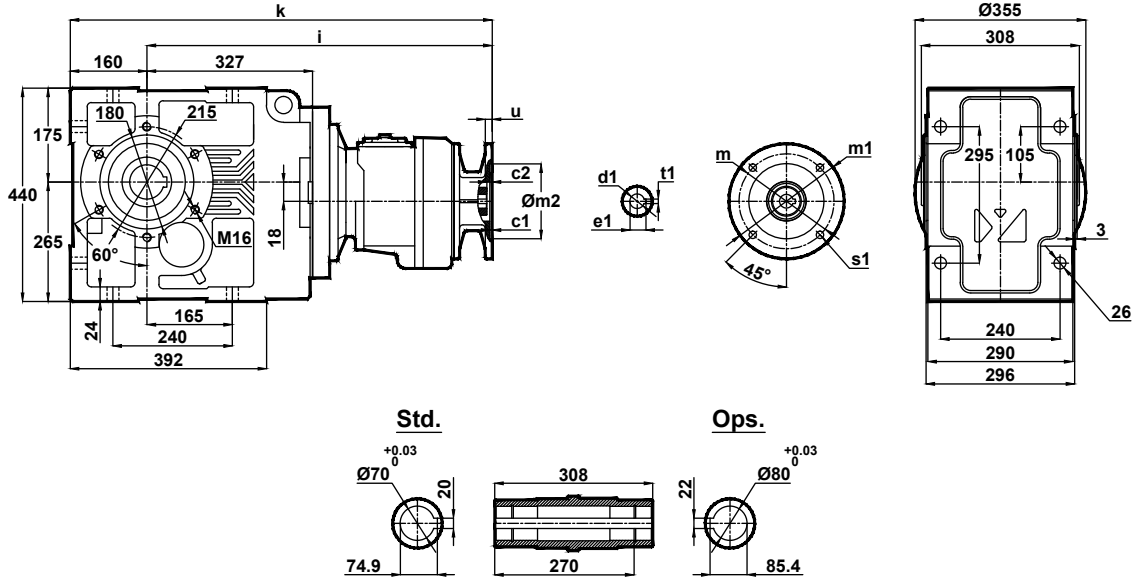

	c1	c2	s1	m	m1	m2	i1	u	k	d1	t1	e1
71/B5	4	9	11	130	160	110	637	12	797	14	5	16.3
80/B5	4	9	13	165	200	130	637	12	797	19	6	21.8
90/B5	4	9	13	165	200	130	637	12	797	24	8	27.3
100/B5	4.5	9	15	215	250	180	654	15	814	28	8	31.3
112/B5	4.5	9	15	215	250	180	654	15	814	28	8	31.3
132/B5	4.5	7	15	265	300	230	674	15	834	38	10	41.3

KN675.01  
KN676.01

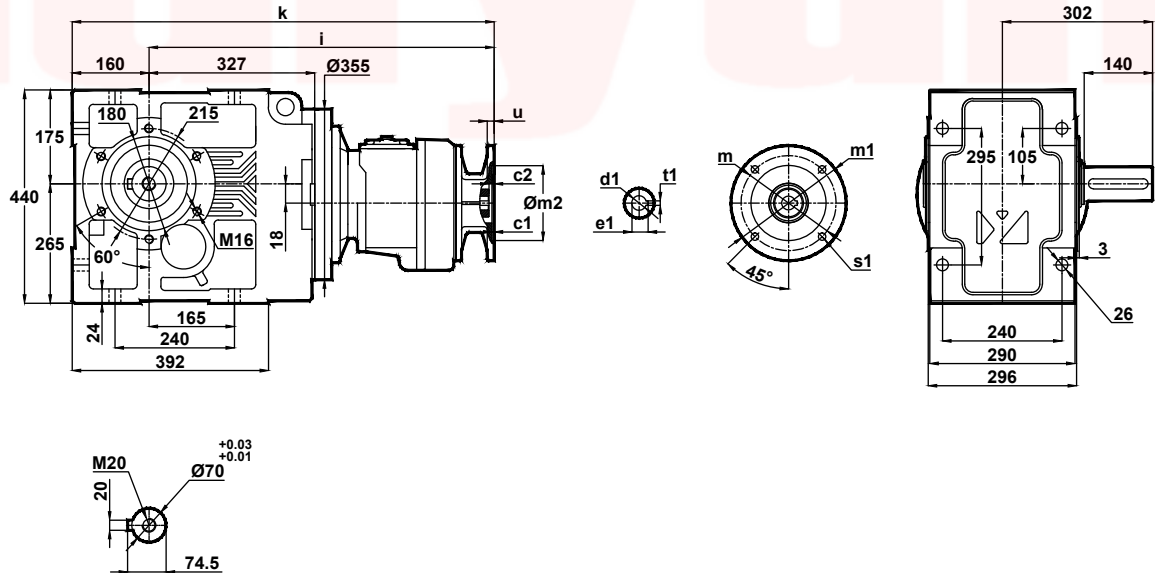

	c1	c2	s1	m	m1	m2	i1	u	k	d1	t1	e1
71/B5	4	9	11	130	160	110	637	12	797	14	5	16.3
80/B5	4	9	13	165	200	130	637	12	797	19	6	21.8
90/B5	4	9	13	165	200	130	637	12	797	24	8	27.3
100/B5	4.5	9	15	215	250	180	654	15	814	28	8	31.3
112/B5	4.5	9	15	215	250	180	654	15	814	28	8	31.3
132/B5	4.5	7	15	265	300	230	674	15	834	38	10	41.3



# Ölçü Sayfaları Dimension Pages Abmessungenseiten



-Mil ucu çekirme deliği DIN 332 sayfa 2 / Tapped center hole to DIN 332, sheet 2 / Zentrierung mit gewinde DIN 332, Blatt 2

KN675.02  
KN676.02

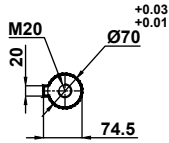
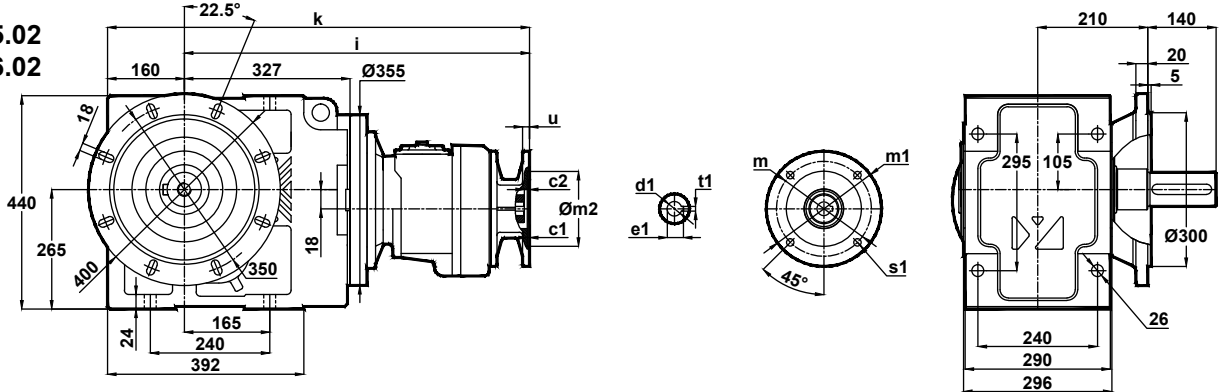

	c1	c2	s1	m	m1	m2	i1	u	k	d1	t1	e1
71/B5	4	9	11	130	160	110	637	12	797	14	5	16.3
80/B5	4	9	13	165	200	130	637	12	797	19	6	21.8
90/B5	4	9	13	165	200	130	637	12	797	24	8	27.3
100/B5	4.5	9	15	215	250	180	654	15	814	28	8	31.3
112/B5	4.5	9	15	215	250	180	654	15	814	28	8	31.3
132/B5	4.5	7	15	265	300	230	674	15	834	38	10	41.3

KN675.03  
KN676.03

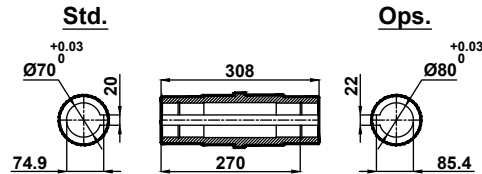
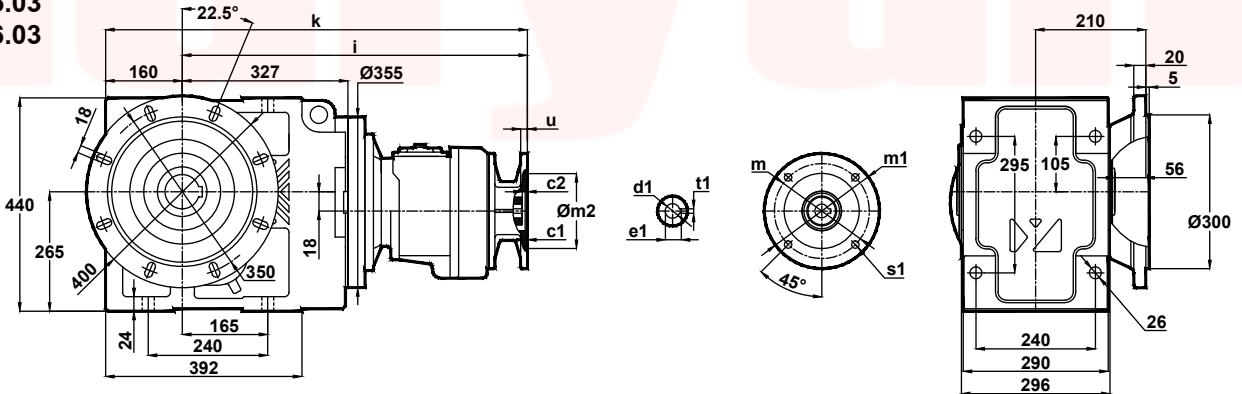

	c1	c2	s1	m	m1	m2	i1	u	k	d1	t1	e1
71/B5	4	9	11	130	160	110	637	12	797	14	5	16.3
80/B5	4	9	13	165	200	130	637	12	797	19	6	21.8
90/B5	4	9	13	165	200	130	637	12	797	24	8	27.3
100/B5	4.5	9	15	215	250	180	654	15	814	28	8	31.3
112/B5	4.5	9	15	215	250	180	654	15	814	28	8	31.3
132/B5	4.5	7	15	265	300	230	674	15	834	38	10	41.3



# Ölçü Sayfaları

## Dimension Pages

### Abmessungsseiten



-Mil ucu çektirme deliği DIN 332 sayfa 2 / Tapped center hole to DIN 332, sheet 2 / Zentrierung mit gewinde DIN 332, Blatt 2

KN675.04  
KN676.04

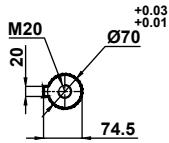
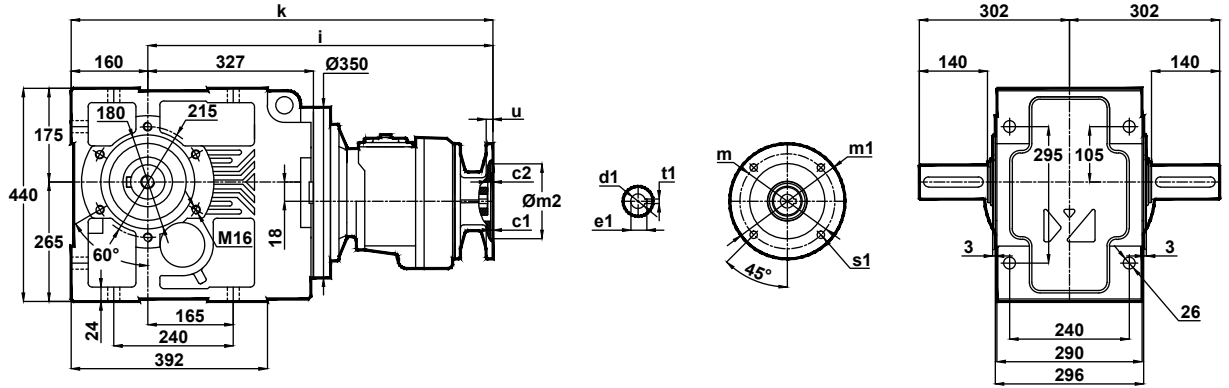

	c1	c2	s1	m	m1	m2	i1	u	k	d1	t1	e1
71/B5	4	9	11	130	160	110	637	12	797	14	5	16.3
80/B5	4	9	13	165	200	130	637	12	797	19	6	21.8
90/B5	4	9	13	165	200	130	637	12	797	24	8	27.3
100/B5	4.5	9	15	215	250	180	654	15	814	28	8	31.3
112/B5	4.5	9	15	215	250	180	654	15	814	28	8	31.3
132/B5	4.5	7	15	265	300	230	674	15	834	38	10	41.3

KN675.05  
KN676.05

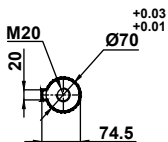
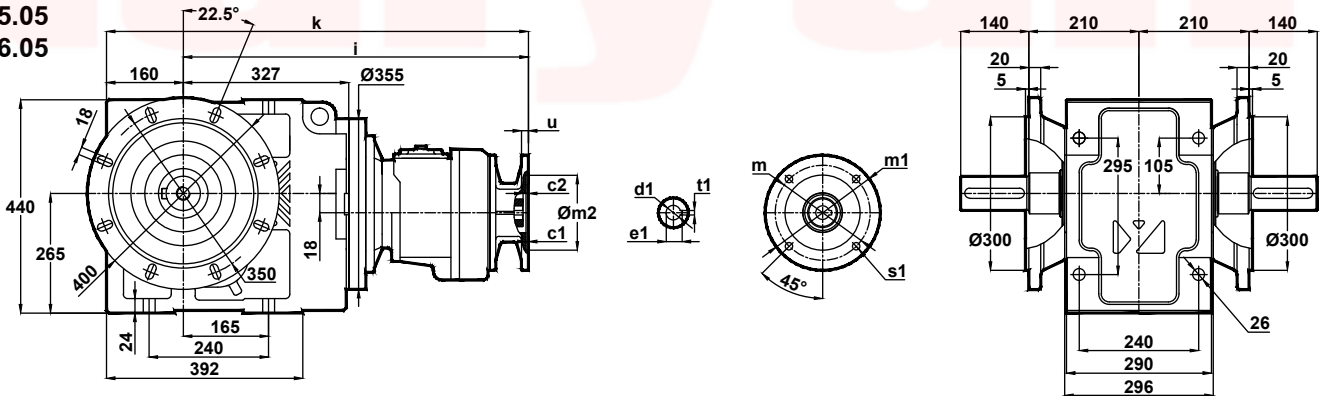

	c1	c2	s1	m	m1	m2	i1	u	k	d1	t1	e1
71/B5	4	9	11	130	160	110	637	12	797	14	5	16.3
80/B5	4	9	13	165	200	130	637	12	797	19	6	21.8
90/B5	4	9	13	165	200	130	637	12	797	24	8	27.3
100/B5	4.5	9	15	215	250	180	654	15	814	28	8	31.3
112/B5	4.5	9	15	215	250	180	654	15	814	28	8	31.3
132/B5	4.5	7	15	265	300	230	674	15	834	38	10	41.3



# Ölçü Sayfaları Dimension Pages Abmessungsseiten



-Mil ucu çekirme deliği DIN 332 sayfa 2 / Tapped center hole to DIN 332, sheet 2 / Zentrierung mit gewinde DIN 332, Blatt 2

KN675.08  
KN676.08

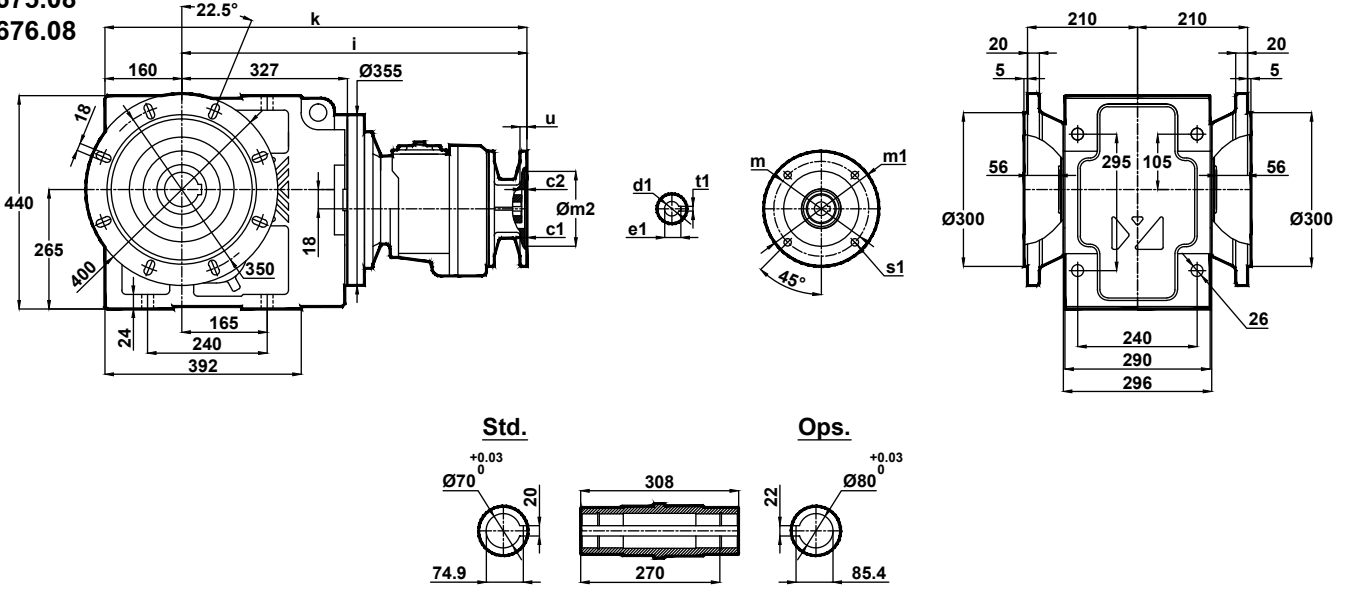

	c1	c2	s1	m	m1	m2	i1	u	k	d1	t1	e1
71/B5	4	9	11	130	160	110	637	12	797	14	5	16.3
80/B5	4	9	13	165	200	130	637	12	797	19	6	21.8
90/B5	4	9	13	165	200	130	637	12	797	24	8	27.3
100/B5	4.5	9	15	215	250	180	654	15	814	28	8	31.3
112/B5	4.5	9	15	215	250	180	654	15	814	28	8	31.3
132/B5	4.5	7	15	265	300	230	674	15	834	38	10	41.3



# Ölçü Sayfaları Dimension Pages Abmessungenseiten



-Mil ucu çekirme deliği DIN 332 sayfa 2 / Tapped center hole to DIN 332, sheet 2 / Zentrierung mit gewinde DIN 332, Blatt 2

## KN773.00

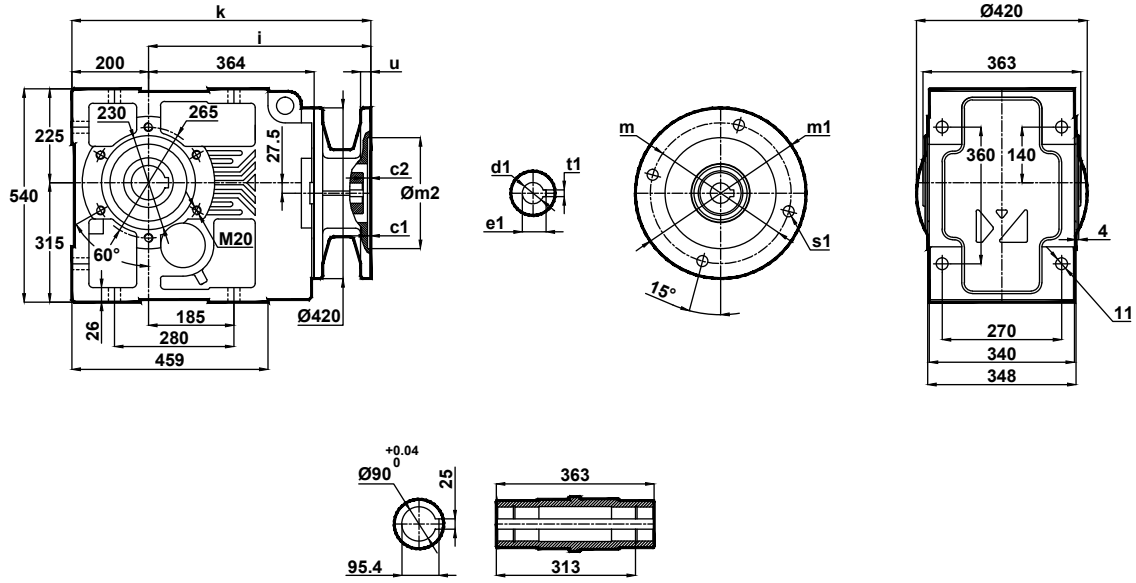

	c1	c2	s1	m	m1	m2	i1	u	k	d1	t1	e1
132/B5	4.5	15	15	265	300	230	84	15	731	38	10	41.3
160/B5	5.5	10	19	300	350	250	153	20	801	42	12	45.3
180/B5	5.5	10	19	300	350	250	153	20	801	48	14	51.8
200/B5	5.5	10	19	350	400	300	175	20	823	55	16	59.3
225/B5	5.5	10	19	400	450	350	228	24	876	60	18	64.4
250/B5	5.5	10	19	500	550	450	228	24	876	65	18	69.4

## KN773.01

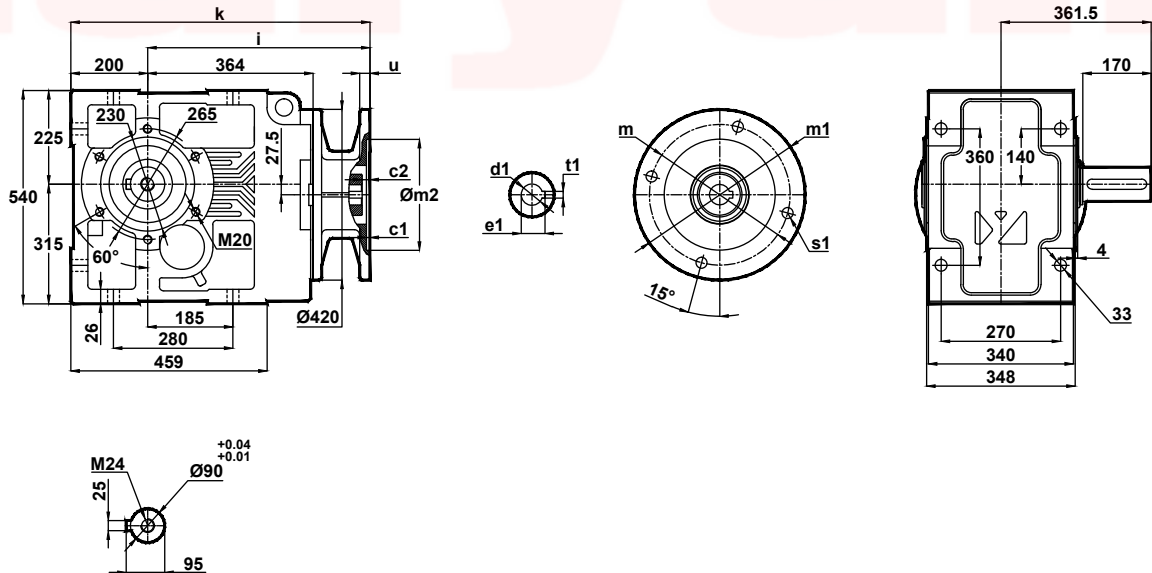

	c1	c2	s1	m	m1	m2	i1	u	k	d1	t1	e1
132/B5	4.5	15	15	265	300	230	84	15	731	38	10	41.3
160/B5	5.5	10	19	300	350	250	153	20	801	42	12	45.3
180/B5	5.5	10	19	300	350	250	153	20	801	48	14	51.8
200/B5	5.5	10	19	350	400	300	175	20	823	55	16	59.3
225/B5	5.5	10	19	400	450	350	228	24	876	60	18	64.4
250/B5	5.5	10	19	500	550	450	228	24	876	65	18	69.4





# Ölçü Sayfaları Dimension Pages Abmessungenseiten



-Mil ucu çektirme deliği DIN 332 sayfa 2 / Tapped center hole to DIN 332, sheet 2 / Zentrierung mit gewinde DIN 332, Blatt 2

## KN773.02

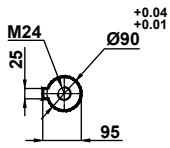
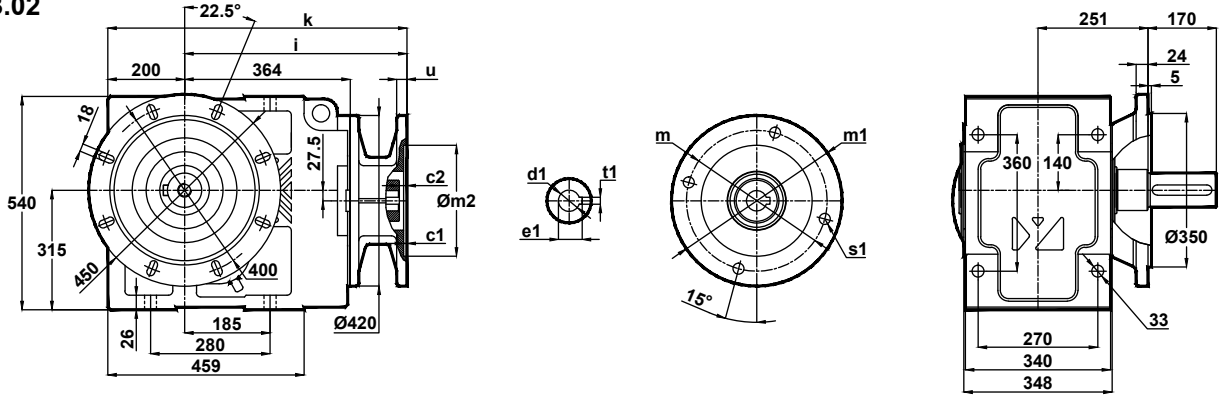

	c1	c2	s1	m	m1	m2	i1	u	k	d1	t1	e1
132/B5	4.5	15	15	265	300	230	84	15	731	38	10	41.3
160/B5	5.5	10	19	300	350	250	153	20	801	42	12	45.3
180/B5	5.5	10	19	300	350	250	153	20	801	48	14	51.8
200/B5	5.5	10	19	350	400	300	175	20	823	55	16	59.3
225/B5	5.5	10	19	400	450	350	228	24	876	60	18	64.4
250/B5	5.5	10	19	500	550	450	228	24	876	65	18	69.4

## KN773.03

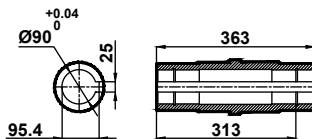
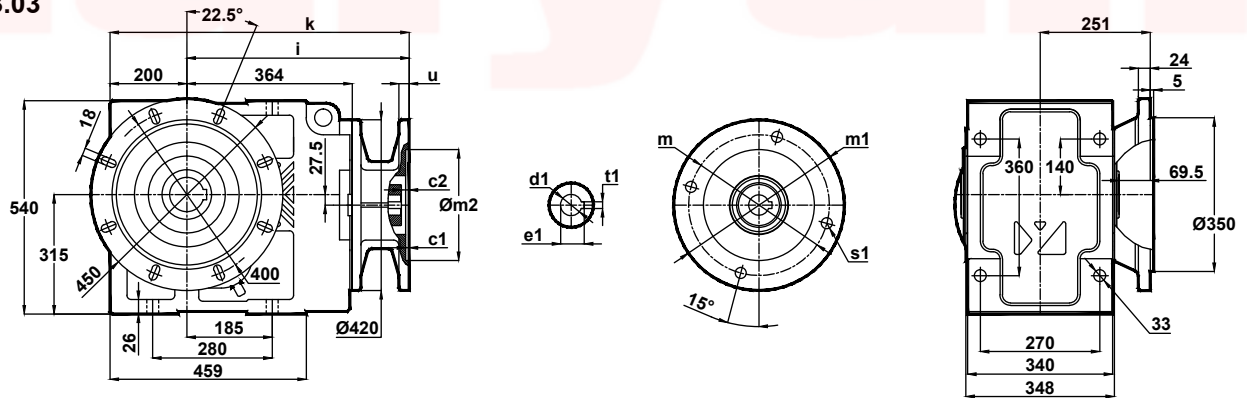

	c1	c2	s1	m	m1	m2	i1	u	k	d1	t1	e1
132/B5	4.5	15	15	265	300	230	84	15	731	38	10	41.3
160/B5	5.5	10	19	300	350	250	153	20	801	42	12	45.3
180/B5	5.5	10	19	300	350	250	153	20	801	48	14	51.8
200/B5	5.5	10	19	350	400	300	175	20	823	55	16	59.3
225/B5	5.5	10	19	400	450	350	228	24	876	60	18	64.4
250/B5	5.5	10	19	500	550	450	228	24	876	65	18	69.4



# Ölçü Sayfaları

## Dimension Pages

### Abmessungsseiten



-Mil ucu çekirme deliği DIN 332 sayfa 2 / Tapped center hole to DIN 332, sheet 2 / Zentrierung mit gewinde DIN 332, Blatt 2

#### KN773.04

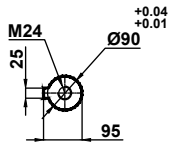
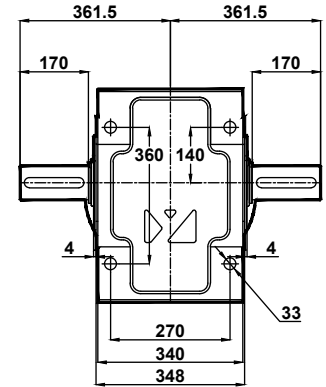
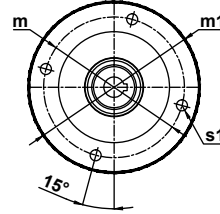
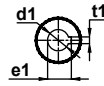
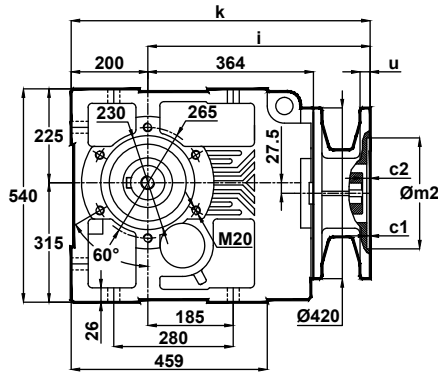

	c1	c2	s1	m	m1	m2	i1	u	k	d1	t1	e1
132/B5	4.5	15	15	265	300	230	84	15	731	38	10	41.3
160/B5	5.5	10	19	300	350	250	153	20	801	42	12	45.3
180/B5	5.5	10	19	300	350	250	153	20	801	48	14	51.8
200/B5	5.5	10	19	350	400	300	175	20	823	55	16	59.3
225/B5	5.5	10	19	400	450	350	228	24	876	60	18	64.4
250/B5	5.5	10	19	500	550	450	228	24	876	65	18	69.4

#### KN773.05

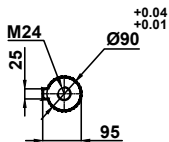
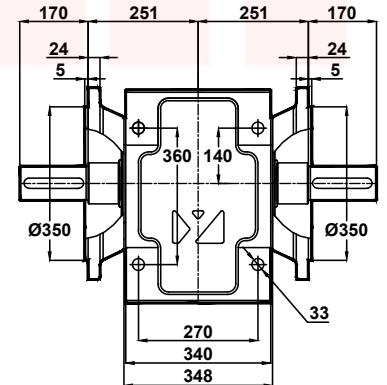
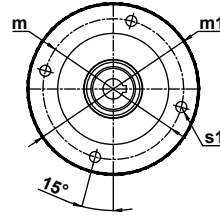
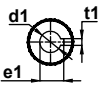
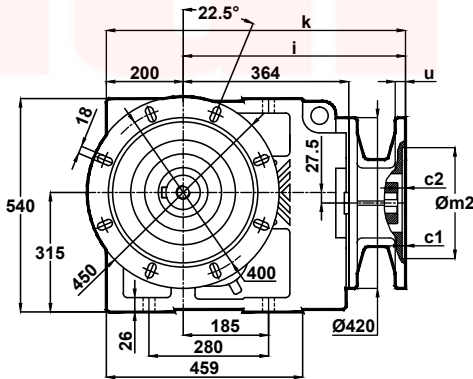

	c1	c2	s1	m	m1	m2	i1	u	k	d1	t1	e1
132/B5	4.5	15	15	265	300	230	84	15	731	38	10	41.3
160/B5	5.5	10	19	300	350	250	153	20	801	42	12	45.3
180/B5	5.5	10	19	300	350	250	153	20	801	48	14	51.8
200/B5	5.5	10	19	350	400	300	175	20	823	55	16	59.3
225/B5	5.5	10	19	400	450	350	228	24	876	60	18	64.4
250/B5	5.5	10	19	500	550	450	228	24	876	65	18	69.4



# Ölçü Sayfaları Dimension Pages Abmessungenseiten



-Mil ucu çekirme deliği DIN 332 sayfa 2 / Tapped center hole to DIN 332, sheet 2 / Zentrierung mit gewinde DIN 332, Blatt 2

KN773.08

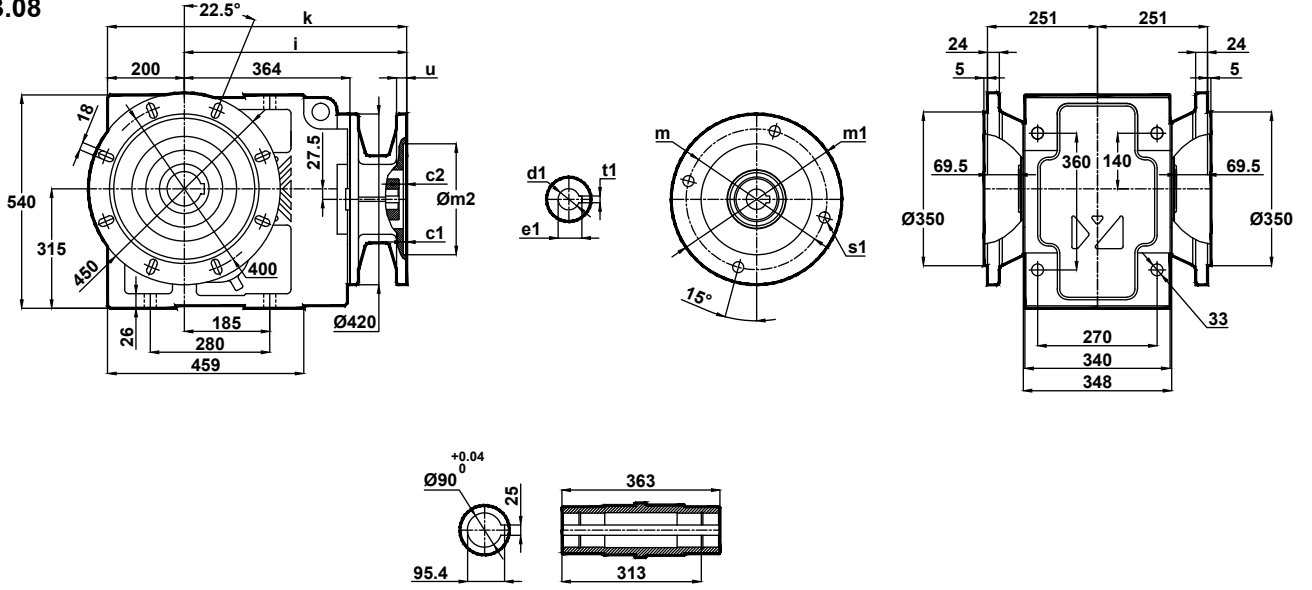

	c1	c2	s1	m	m1	m2	i1	u	k	d1	t1	e1
132/B5	4.5	15	15	265	300	230	84	15	731	38	10	41.3
160/B5	5.5	10	19	300	350	250	153	20	801	42	12	45.3
180/B5	5.5	10	19	300	350	250	153	20	801	48	14	51.8
200/B5	5.5	10	19	350	400	300	175	20	823	55	16	59.3
225/B5	5.5	10	19	400	450	350	228	24	876	60	18	64.4
250/B5	5.5	10	19	500	550	450	228	24	876	65	18	69.4



# Ölçü Sayfaları

## Dimension Pages

### Abmessungsseiten



-Mil ucu çekirme deliği DIN 332 sayfa 2 / Tapped center hole to DIN 332, sheet 2 / Zentrierung mit gewinde DIN 332, Blatt 2

#### KN774.00

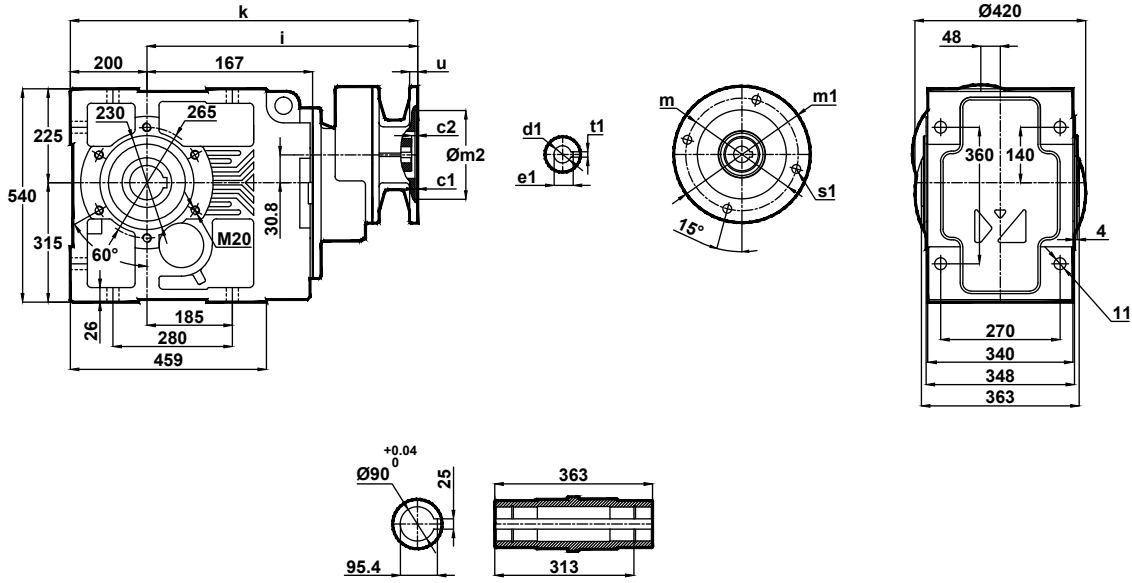

	c1	c2	s1	m	m1	m2	i1	u	k	d1	t1	e1
80/B5	4	5	12	162	200	130	523	12	612	19	6	21.8
90/B5	4	5	13	165	200	130	541	12	631	24	8	27.3
100/B5	4.5	9	15	215	250	180	541	15	631	28	8	31.3
112/B5	4.5	9	15	215	250	180	560	15	649	28	8	31.3
132/B5	4.5	6	15	265	300	230	639	15	729	38	10	41.3
160/B5	5.5	10	19	300	350	250	639	20	729	42	12	45.3
180/B5	5.5	10	19	300	350	250	639	20	729	48	14	51.8

#### KN774.01

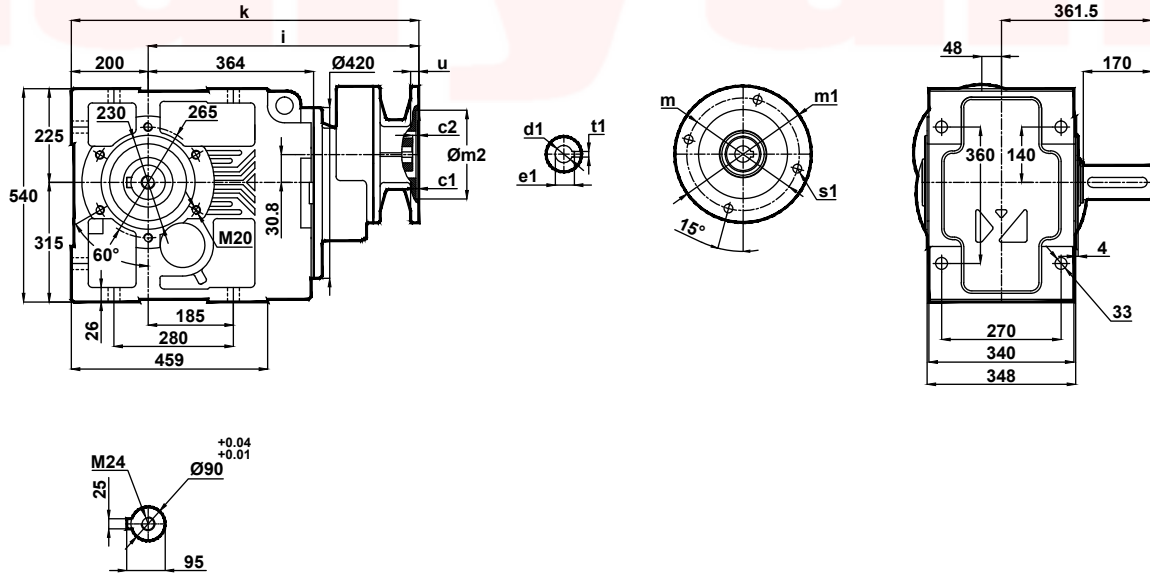

	c1	c2	s1	m	m1	m2	i1	u	k	d1	t1	e1
80/B5	4	5	12	162	200	130	523	12	612	19	6	21.8
90/B5	4	5	13	165	200	130	541	12	631	24	8	27.3
100/B5	4.5	9	15	215	250	180	541	15	631	28	8	31.3
112/B5	4.5	9	15	215	250	180	560	15	649	28	8	31.3
132/B5	4.5	6	15	265	300	230	639	15	729	38	10	41.3
160/B5	5.5	10	19	300	350	250	639	20	729	42	12	45.3
180/B5	5.5	10	19	300	350	250	639	20	729	48	14	51.8



# Ölçü Sayfaları Dimension Pages Abmessungsseiten



-Mil ucu çekirme deliği DIN 332 sayfa 2 / Tapped center hole to DIN 332, sheet 2 / Zentrierung mit gewinde DIN 332, Blatt 2

## KN774.02

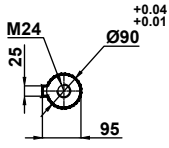
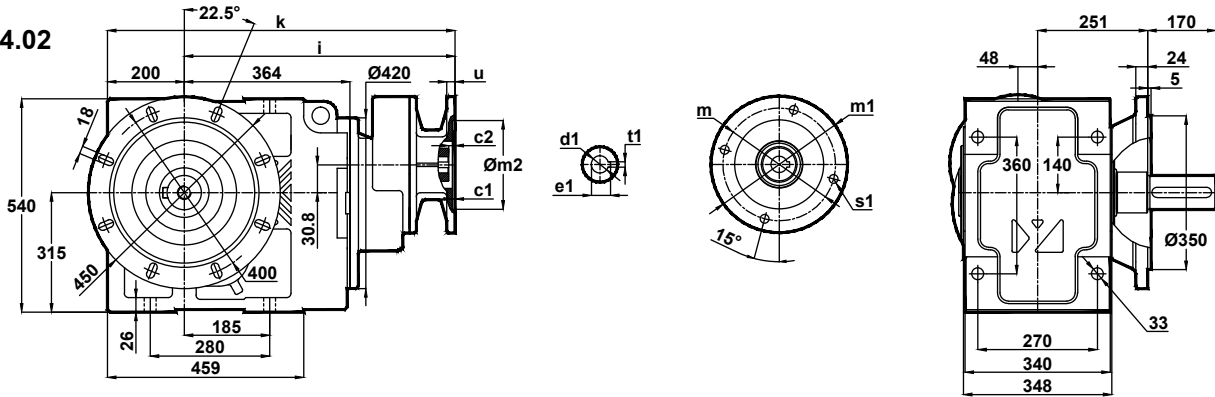

	c1	c2	s1	m	m1	m2	i1	u	k	d1	t1	e1
80/B5	4	5	12	162	200	130	523	12	612	19	6	21.8
90/B5	4	5	13	165	200	130	541	12	631	24	8	27.3
100/B5	4.5	9	15	215	250	180	541	15	631	28	8	31.3
112/B5	4.5	9	15	215	250	180	560	15	649	28	8	31.3
132/B5	4.5	6	15	265	300	230	639	15	729	38	10	41.3
160/B5	5.5	10	19	300	350	250	639	20	729	42	12	45.3
180/B5	5.5	10	19	300	350	250	639	20	729	48	14	51.8

## KN774.03

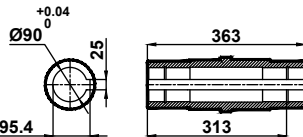
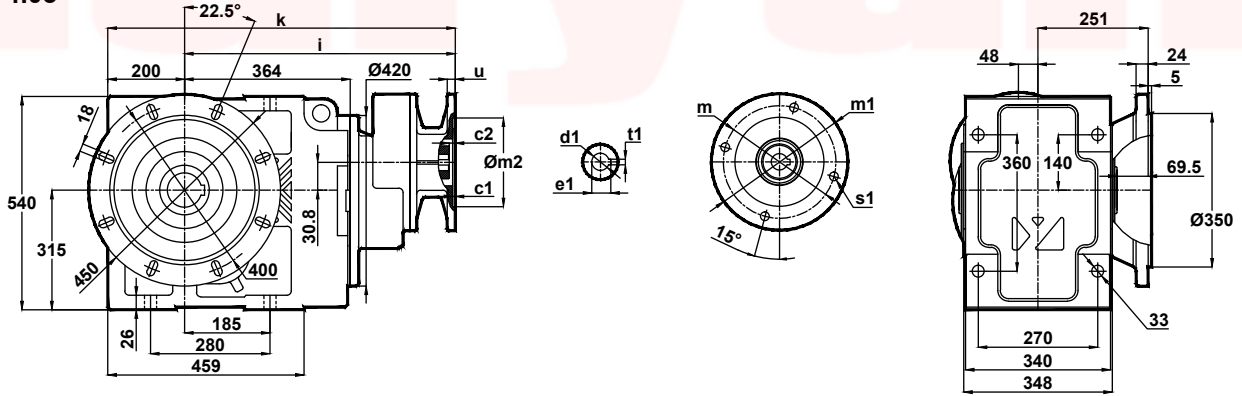

	c1	c2	s1	m	m1	m2	i1	u	k	d1	t1	e1
80/B5	4	5	12	162	200	130	523	12	612	19	6	21.8
90/B5	4	5	13	165	200	130	541	12	631	24	8	27.3
100/B5	4.5	9	15	215	250	180	541	15	631	28	8	31.3
112/B5	4.5	9	15	215	250	180	560	15	649	28	8	31.3
132/B5	4.5	6	15	265	300	230	639	15	729	38	10	41.3
160/B5	5.5	10	19	300	350	250	639	20	729	42	12	45.3
180/B5	5.5	10	19	300	350	250	639	20	729	48	14	51.8



# Ölçü Sayfaları

## Dimension Pages

### Abmessungsseiten



-Mil ucu çekirme deliği DIN 332 sayfa 2 / Tapped center hole to DIN 332, sheet 2 / Zentrierung mit gewinde DIN 332, Blatt 2

#### KN774.04

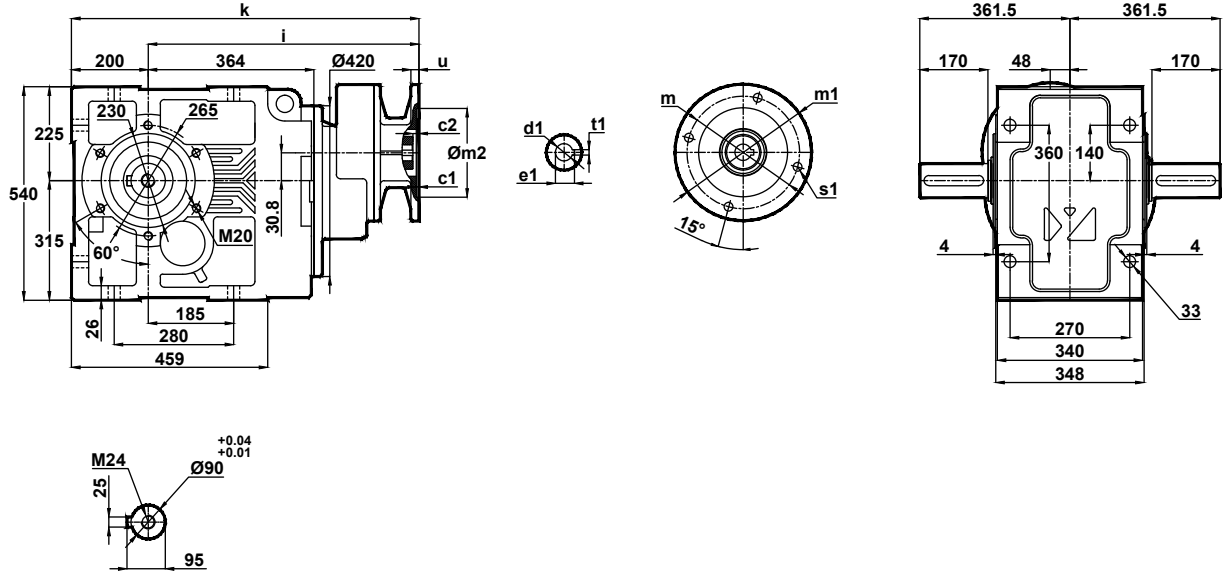

	c1	c2	s1	m	m1	m2	i1	u	k	d1	t1	e1
80/B5	4	5	12	162	200	130	523	12	612	19	6	21.8
90/B5	4	5	13	165	200	130	541	12	631	24	8	27.3
100/B5	4.5	9	15	215	250	180	541	15	631	28	8	31.3
112/B5	4.5	9	15	215	250	180	560	15	649	28	8	31.3
132/B5	4.5	6	15	265	300	230	639	15	729	38	10	41.3
160/B5	5.5	10	19	300	350	250	639	20	729	42	12	45.3
180/B5	5.5	10	19	300	350	250	639	20	729	48	14	51.8

#### KN774.05

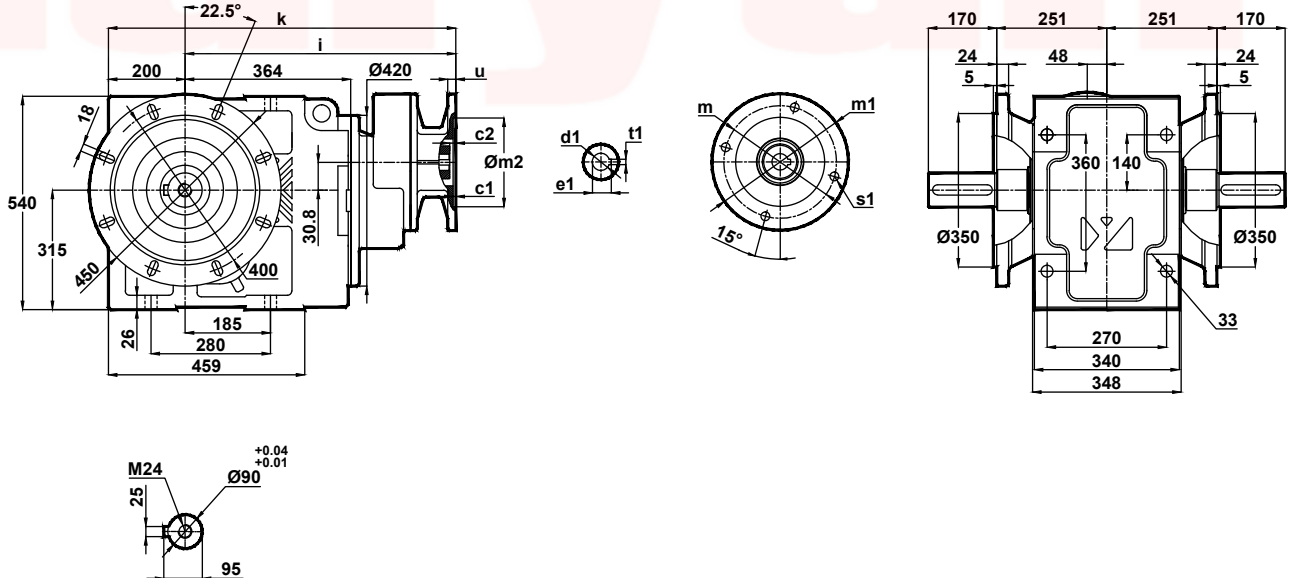

	c1	c2	s1	m	m1	m2	i1	u	k	d1	t1	e1
80/B5	4	5	12	162	200	130	523	12	612	19	6	21.8
90/B5	4	5	13	165	200	130	541	12	631	24	8	27.3
100/B5	4.5	9	15	215	250	180	541	15	631	28	8	31.3
112/B5	4.5	9	15	215	250	180	560	15	649	28	8	31.3
132/B5	4.5	6	15	265	300	230	639	15	729	38	10	41.3
160/B5	5.5	10	19	300	350	250	639	20	729	42	12	45.3
180/B5	5.5	10	19	300	350	250	639	20	729	48	14	51.8



# Ölçü Sayfaları Dimension Pages Abmessungenseiten



-Mil ucu çekirme deliği DIN 332 sayfa 2 / Tapped center hole to DIN 332, sheet 2 / Zentrierung mit gewinde DIN 332, Blatt 2

KN774.08

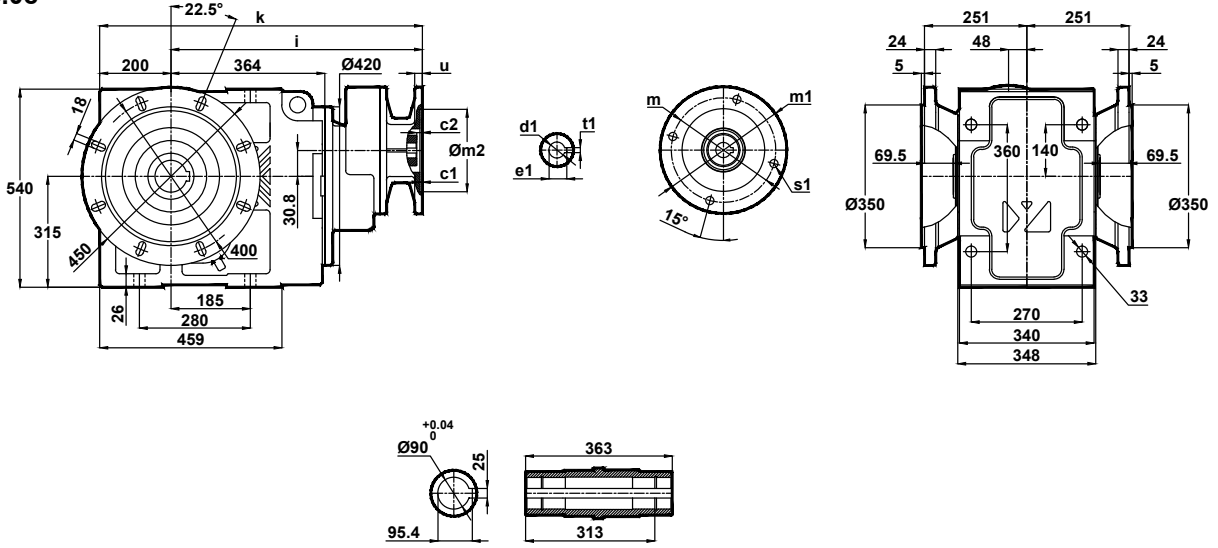

	c1	c2	s1	m	m1	m2	i1	u	k	d1	t1	e1
80/B5	4	5	12	162	200	130	523	12	612	19	6	21.8
90/B5	4	5	13	165	200	130	541	12	631	24	8	27.3
100/B5	4.5	9	15	215	250	180	541	15	631	28	8	31.3
112/B5	4.5	9	15	215	250	180	560	15	649	28	8	31.3
132/B5	4.5	6	15	265	300	230	639	15	729	38	10	41.3
160/B5	5.5	10	19	300	350	250	639	20	729	42	12	45.3
180/B5	5.5	10	19	300	350	250	639	20	729	48	14	51.8



# Ölçü Sayfaları

## Dimension Pages

### Abmessungsseiten



-Mil ucu çekirme deliği DIN 332 sayfa 2 / Tapped center hole to DIN 332, sheet 2 / Zentrierung mit gewinde DIN 332, Blatt 2

KN775.00  
KN776.00

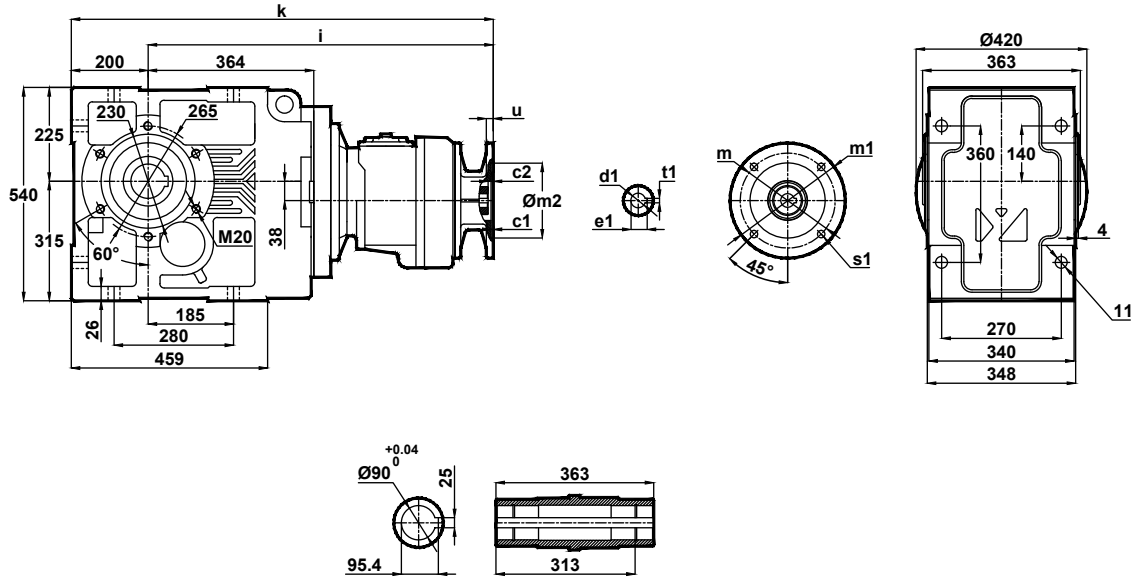

	c1	c2	s1	m	m1	m2	i1	u	k	d1	t1	e1
71/B5	4	9	11	130	160	110	674	12	874	14	5	16.3
80/B5	4	9	13	165	200	130	674	12	874	19	6	21.8
90/B5	4	9	13	165	200	130	674	12	874	24	8	27.3
100/B5	4.5	9	15	215	250	180	691	15	891	28	8	31.3
112/B5	4.5	9	15	215	250	180	691	15	891	28	8	31.3
132/B5	4.5	7	15	265	300	230	711	15	911	38	10	41.3

KN775.01  
KN776.01

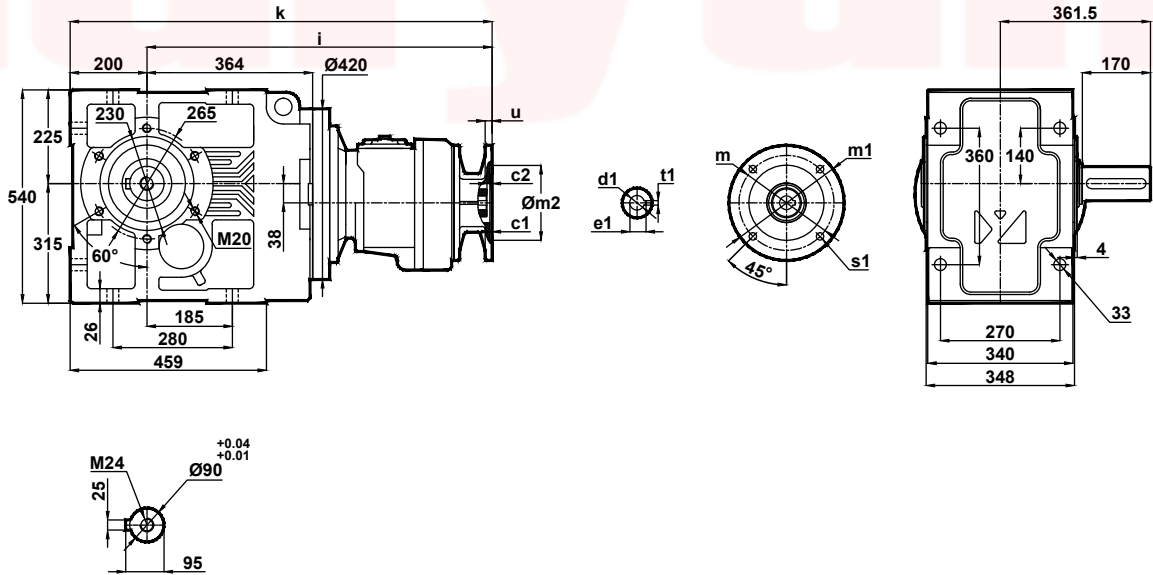

	c1	c2	s1	m	m1	m2	i1	u	k	d1	t1	e1
71/B5	4	9	11	130	160	110	674	12	874	14	5	16.3
80/B5	4	9	13	165	200	130	674	12	874	19	6	21.8
90/B5	4	9	13	165	200	130	674	12	874	24	8	27.3
100/B5	4.5	9	15	215	250	180	691	15	891	28	8	31.3
112/B5	4.5	9	15	215	250	180	691	15	891	28	8	31.3
132/B5	4.5	7	15	265	300	230	711	15	911	38	10	41.3





# Ölçü Sayfaları Dimension Pages Abmessungenseiten



-Mil ucu çekirme deliği DIN 332 sayfa 2 / Tapped center hole to DIN 332, sheet 2 / Zentrierung mit gewinde DIN 332, Blatt 2

KN775.02  
KN776.02

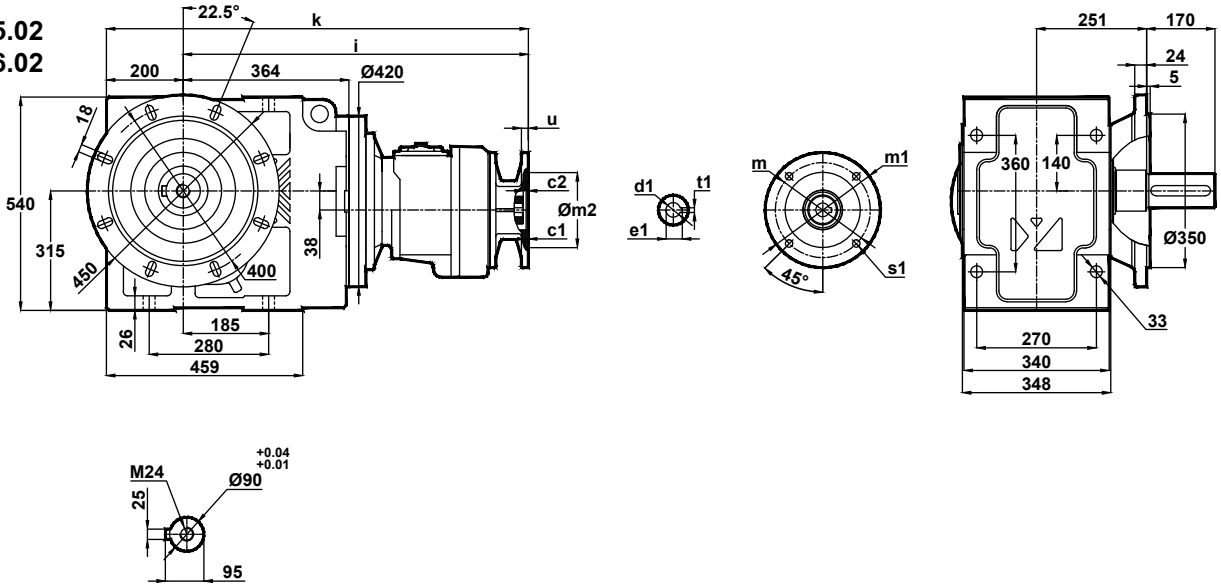

	c1	c2	s1	m	m1	m2	i1	u	k	d1	t1	e1
71/B5	4	9	11	130	160	110	674	12	874	14	5	16.3
80/B5	4	9	13	165	200	130	674	12	874	19	6	21.8
90/B5	4	9	13	165	200	130	674	12	874	24	8	27.3
100/B5	4.5	9	15	215	250	180	691	15	891	28	8	31.3
112/B5	4.5	9	15	215	250	180	691	15	891	28	8	31.3
132/B5	4.5	7	15	265	300	230	711	15	911	38	10	41.3

KN775.03  
KN776.03

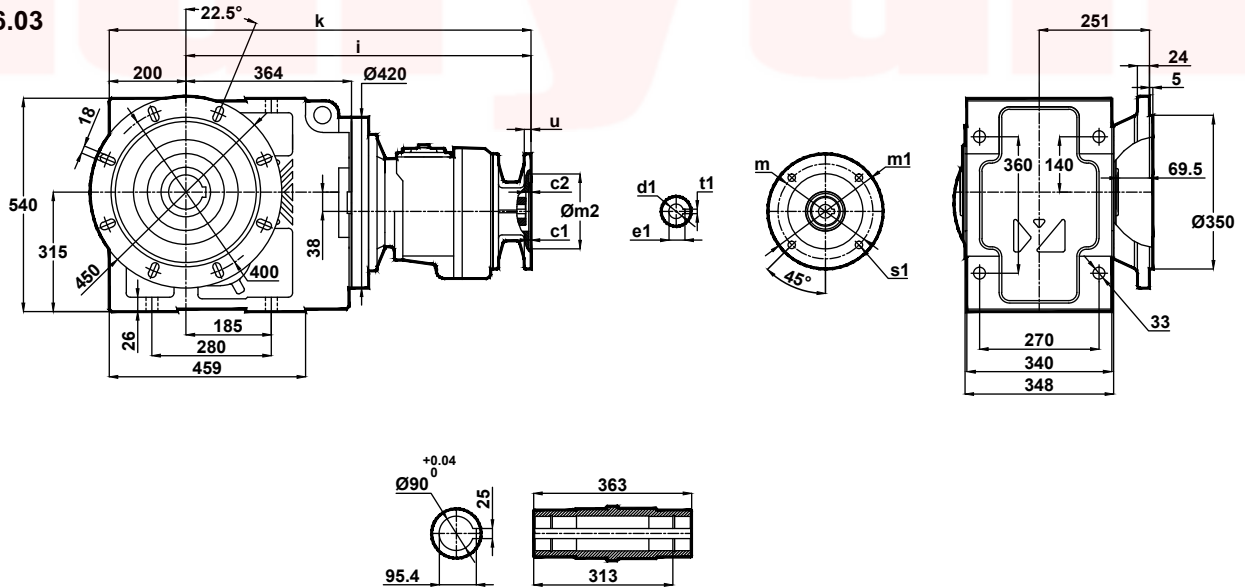

	c1	c2	s1	m	m1	m2	i1	u	k	d1	t1	e1
71/B5	4	9	11	130	160	110	674	12	874	14	5	16.3
80/B5	4	9	13	165	200	130	674	12	874	19	6	21.8
90/B5	4	9	13	165	200	130	674	12	874	24	8	27.3
100/B5	4.5	9	15	215	250	180	691	15	891	28	8	31.3
112/B5	4.5	9	15	215	250	180	691	15	891	28	8	31.3
132/B5	4.5	7	15	265	300	230	711	15	911	38	10	41.3



# Ölçü Sayfaları

## Dimension Pages

### Abmessungsseiten



-Mil ucu çekirme deliği DIN 332 sayfa 2 / Tapped center hole to DIN 332, sheet 2 / Zentrierung mit gewinde DIN 332, Blatt 2

KN775.04  
KN776.04

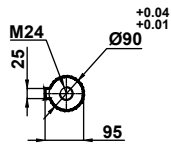
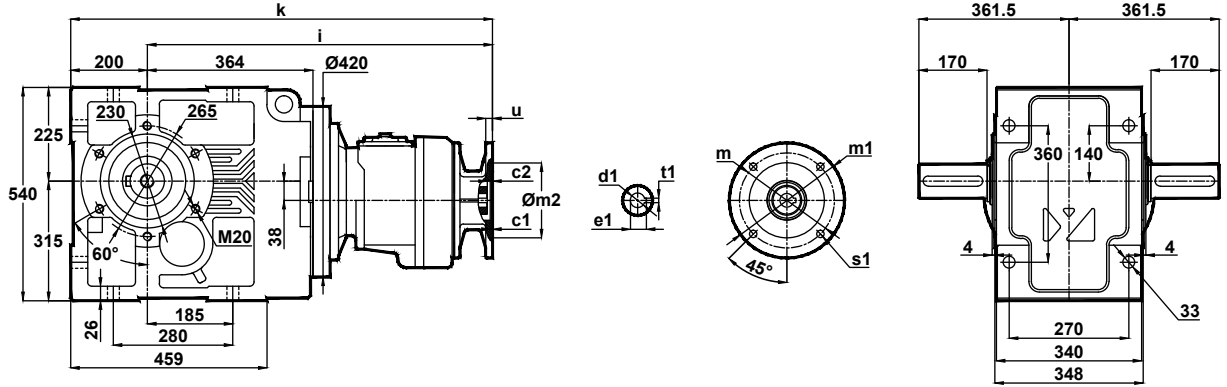

	c1	c2	s1	m	m1	m2	i1	u	k	d1	t1	e1
71/B5	4	9	11	130	160	110	674	12	874	14	5	16.3
80/B5	4	9	13	165	200	130	674	12	874	19	6	21.8
90/B5	4	9	13	165	200	130	674	12	874	24	8	27.3
100/B5	4.5	9	15	215	250	180	691	15	891	28	8	31.3
112/B5	4.5	9	15	215	250	180	691	15	891	28	8	31.3
132/B5	4.5	7	15	265	300	230	711	15	911	38	10	41.3

KN775.05  
KN776.05

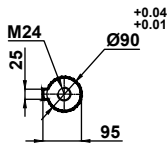
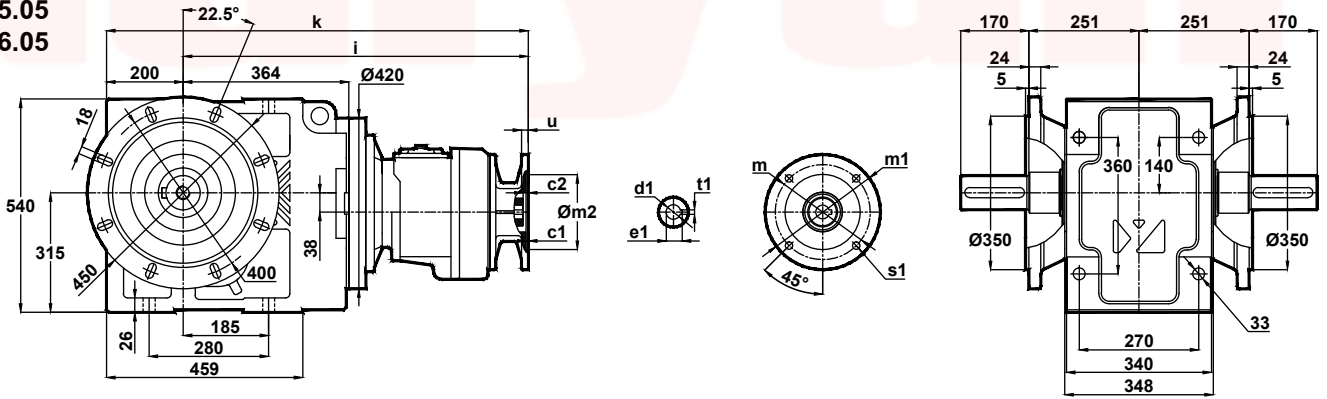

	c1	c2	s1	m	m1	m2	i1	u	k	d1	t1	e1
71/B5	4	9	11	130	160	110	674	12	874	14	5	16.3
80/B5	4	9	13	165	200	130	674	12	874	19	6	21.8
90/B5	4	9	13	165	200	130	674	12	874	24	8	27.3
100/B5	4.5	9	15	215	250	180	691	15	891	28	8	31.3
112/B5	4.5	9	15	215	250	180	691	15	891	28	8	31.3
132/B5	4.5	7	15	265	300	230	711	15	911	38	10	41.3



# Ölçü Sayfaları Dimension Pages Abmessungenseiten



-Mil ucu çekirme deliği DIN 332 sayfa 2 / Tapped center hole to DIN 332, sheet 2 / Zentrierung mit gewinde DIN 332, Blatt 2

KN775.08  
KN776.08

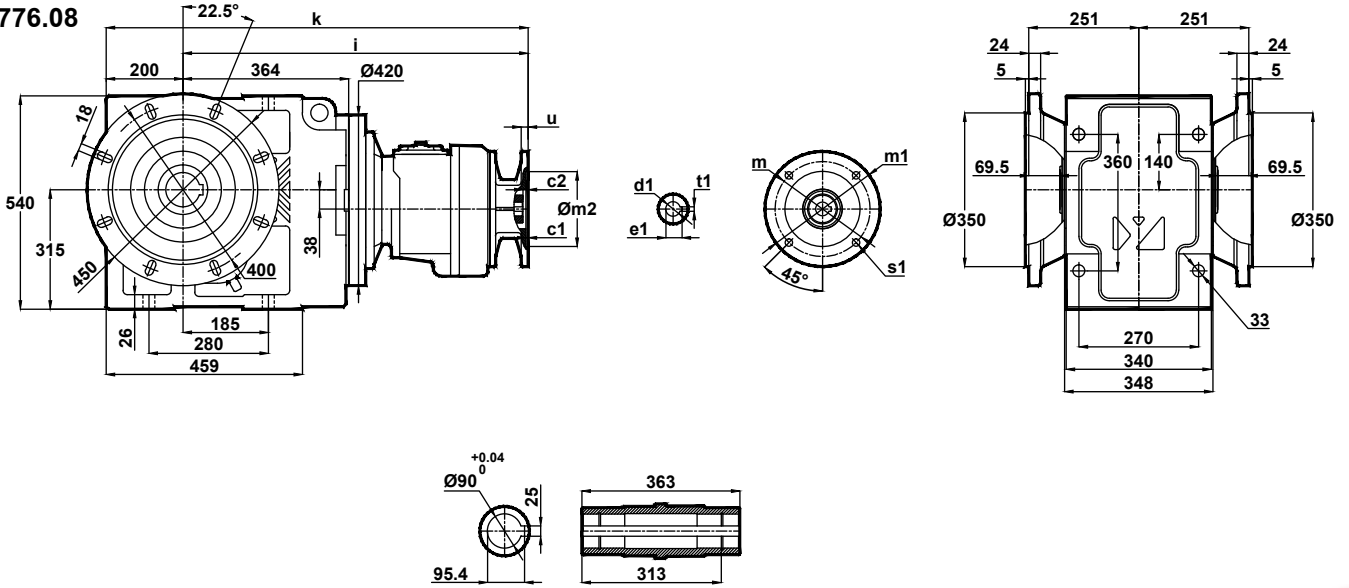

	c1	c2	s1	m	m1	m2	i1	u	k	d1	t1	e1
71/B5	4	9	11	130	160	110	674	12	874	14	5	16.3
80/B5	4	9	13	165	200	130	674	12	874	19	6	21.8
90/B5	4	9	13	165	200	130	674	12	874	24	8	27.3
100/B5	4.5	9	15	215	250	180	691	15	891	28	8	31.3
112/B5	4.5	9	15	215	250	180	691	15	891	28	8	31.3
132/B5	4.5	7	15	265	300	230	711	15	911	38	10	41.3



# Ölçü Sayfaları Dimension Pages Abmessungsseiten



-Mil ucu çekirme deliği DIN 332 sayfa 2 / Tapped center hole to DIN 332, sheet 2 / Zentrierung mit gewinde DIN 332, Blatt 2

## KN873.00

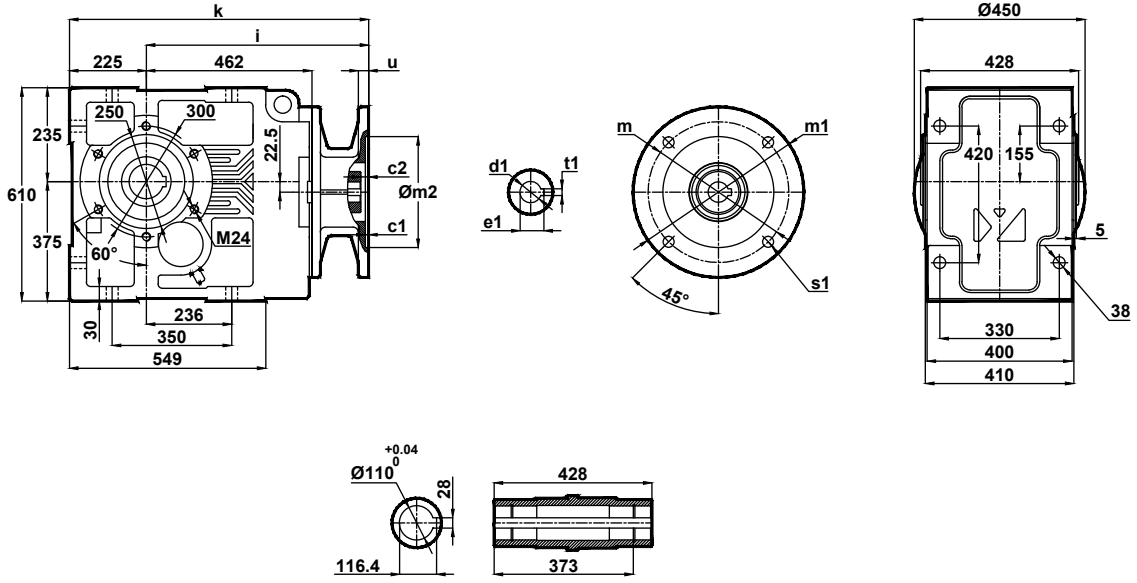

	c1	c2	s1	m	m1	m2	i1	u	k	d1	t1	e1
132/B5	4.5	14	15	265	300	230	218	15	1123	38	10	41.3
160/B5	5.5	10	19	300	350	250	218	20	1123	42	12	45.3
180/B5	5.5	10	19	300	350	250	218	20	1123	48	14	51.8
200/B4	5.5	10	19	350	400	300	218	22	1123	55	16	59.3
225/B5	5.5	10	19	400	450	350	218	24	1123	60	18	64.4
250/B5	5.5	10	19	500	550	450	218	24	1123	65	18	69.4
280/B5	5.5	10	19	500	550	450	218	24	1123	75	20	79.9

## KN873.01

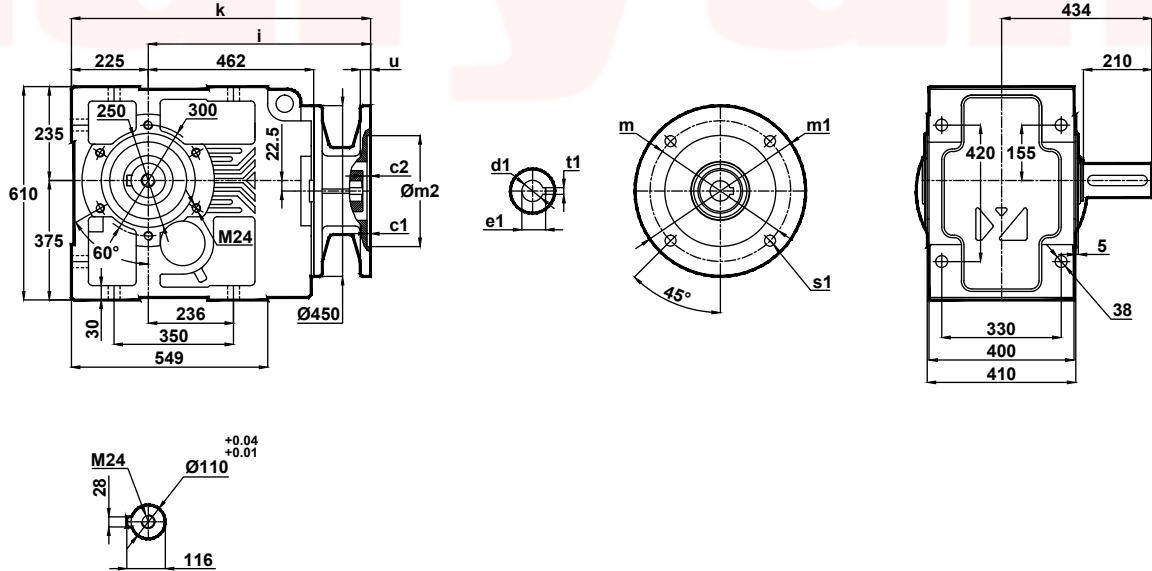

	c1	c2	s1	m	m1	m2	i1	u	k	d1	t1	e1
132/B5	4.5	14	15	265	300	230	218	15	1123	38	10	41.3
160/B5	5.5	10	19	300	350	250	218	20	1123	42	12	45.3
180/B5	5.5	10	19	300	350	250	218	20	1123	48	14	51.8
200/B4	5.5	10	19	350	400	300	218	22	1123	55	16	59.3
225/B5	5.5	10	19	400	450	350	218	24	1123	60	18	64.4
250/B5	5.5	10	19	500	550	450	218	24	1123	65	18	69.4
280/B5	5.5	10	19	500	550	450	218	24	1123	75	20	79.9



# Ölçü Sayfaları Dimension Pages Abmessungsseiten



-Mil ucu çekirme deliği DIN 332 sayfa 2 / Tapped center hole to DIN 332, sheet 2 / Zentrierung mit gewinde DIN 332, Blatt 2

KN873.02

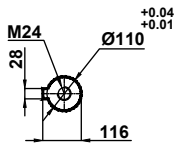
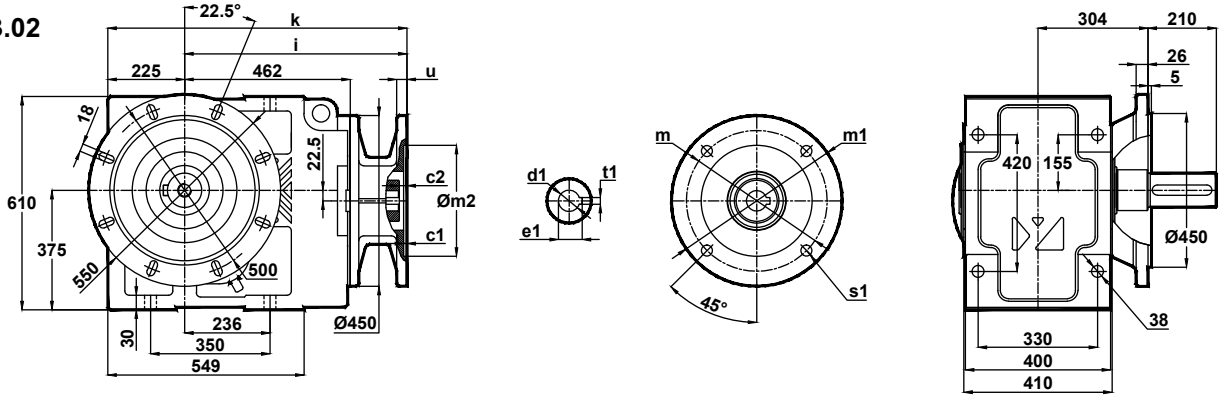

	c1	c2	s1	m	m1	m2	i1	u	k	d1	t1	e1
132/B5	4.5	14	15	265	300	230	218	15	1123	38	10	41.3
160/B5	5.5	10	19	300	350	250	218	20	1123	42	12	45.3
180/B5	5.5	10	19	300	350	250	218	20	1123	48	14	51.8
200/B4	5.5	10	19	350	400	300	218	22	1123	55	16	59.3
225/B5	5.5	10	19	400	450	350	218	24	1123	60	18	64.4
250/B5	5.5	10	19	500	550	450	218	24	1123	65	18	69.4
280/B5	5.5	10	19	500	550	450	218	24	1123	75	20	79.9

KN873.03

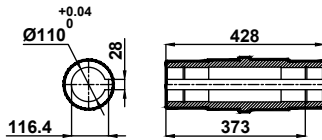
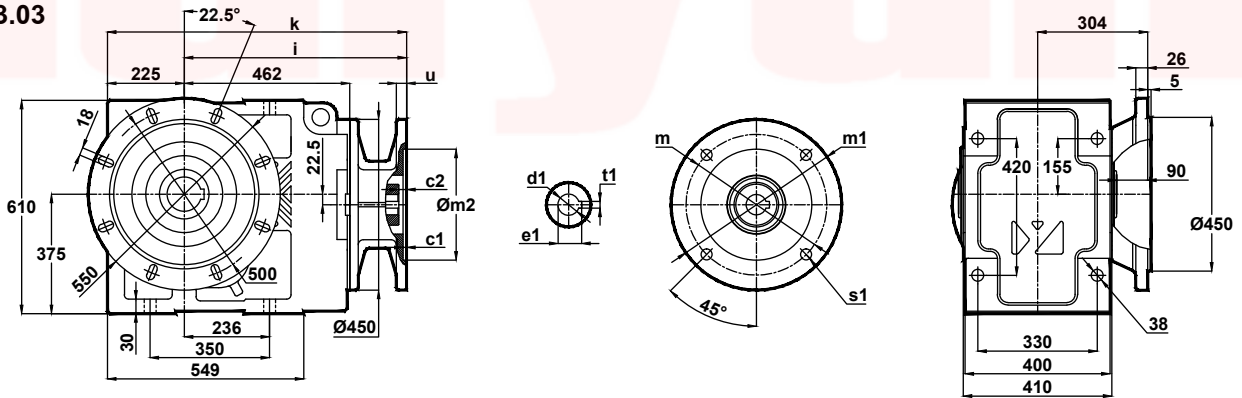

	c1	c2	s1	m	m1	m2	i1	u	k	d1	t1	e1
132/B5	4.5	14	15	265	300	230	218	15	1123	38	10	41.3
160/B5	5.5	10	19	300	350	250	218	20	1123	42	12	45.3
180/B5	5.5	10	19	300	350	250	218	20	1123	48	14	51.8
200/B4	5.5	10	19	350	400	300	218	22	1123	55	16	59.3
225/B5	5.5	10	19	400	450	350	218	24	1123	60	18	64.4
250/B5	5.5	10	19	500	550	450	218	24	1123	65	18	69.4
280/B5	5.5	10	19	500	550	450	218	24	1123	75	20	79.9



# Ölçü Sayfaları Dimension Pages Abmessungsseiten



-Mil ucu çekirme deliği DIN 332 sayfa 2 / Tapped center hole to DIN 332, sheet 2 / Zentrierung mit gewinde DIN 332, Blatt 2

## KN873.04

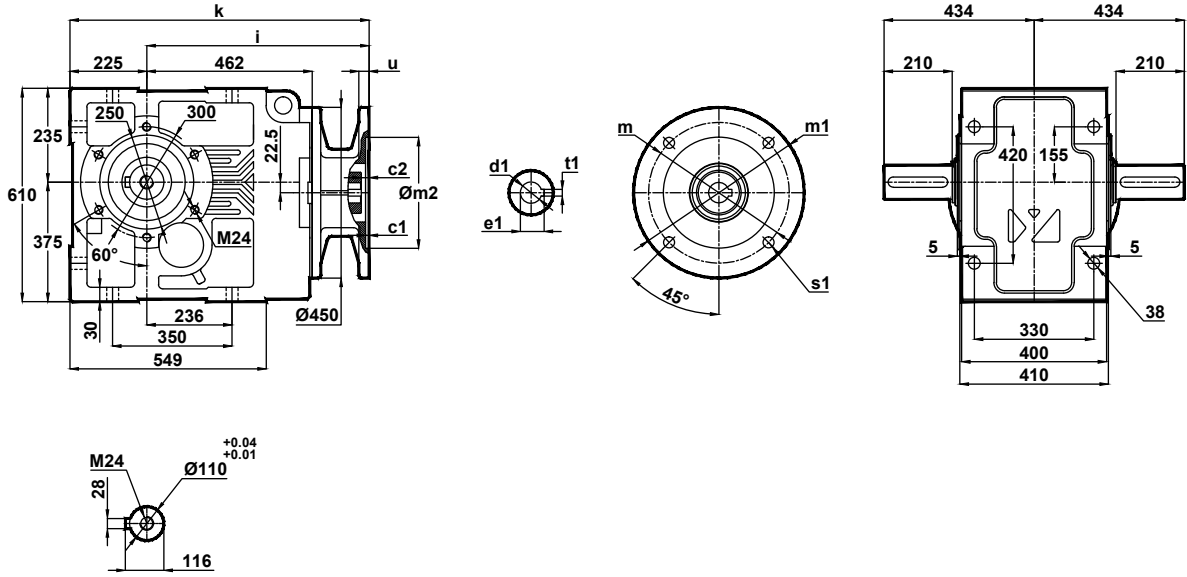

	c1	c2	s1	m	m1	m2	i1	u	k	d1	t1	e1
132/B5	4.5	14	15	265	300	230	218	15	1123	38	10	41.3
160/B5	5.5	10	19	300	350	250	218	20	1123	42	12	45.3
180/B5	5.5	10	19	300	350	250	218	20	1123	48	14	51.8
200/B4	5.5	10	19	350	400	300	218	22	1123	55	16	59.3
225/B5	5.5	10	19	400	450	350	218	24	1123	60	18	64.4
250/B5	5.5	10	19	500	550	450	218	24	1123	65	18	69.4
280/B5	5.5	10	19	500	550	450	218	24	1123	75	20	79.9

## KN873.05

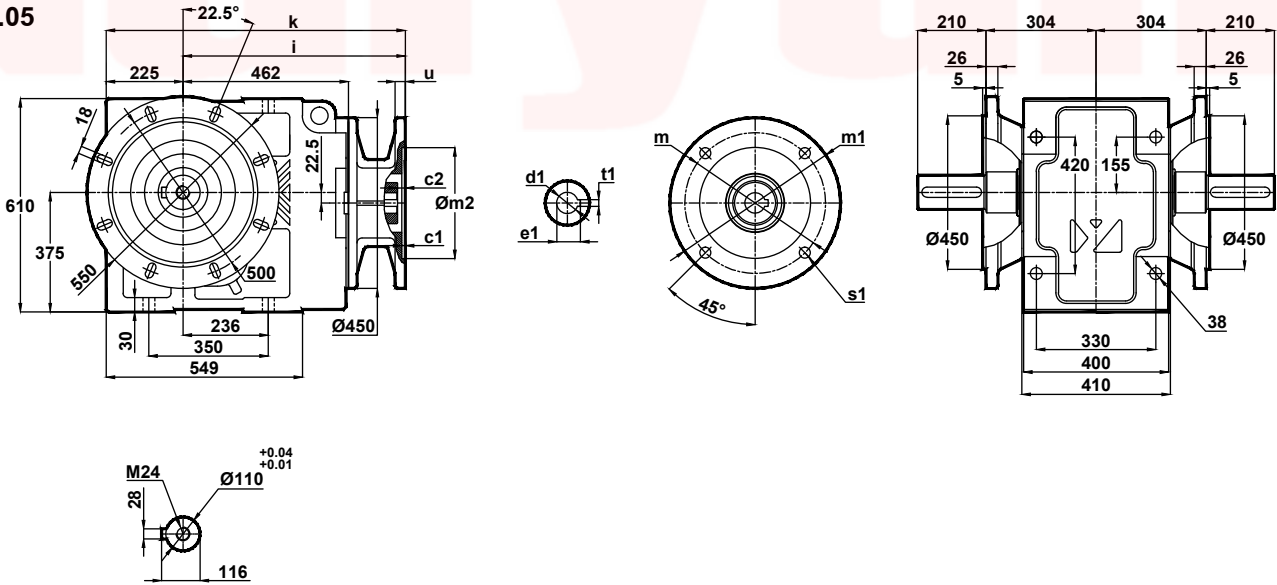

	c1	c2	s1	m	m1	m2	i1	u	k	d1	t1	e1
132/B5	4.5	14	15	265	300	230	218	15	1123	38	10	41.3
160/B5	5.5	10	19	300	350	250	218	20	1123	42	12	45.3
180/B5	5.5	10	19	300	350	250	218	20	1123	48	14	51.8
200/B4	5.5	10	19	350	400	300	218	22	1123	55	16	59.3
225/B5	5.5	10	19	400	450	350	218	24	1123	60	18	64.4
250/B5	5.5	10	19	500	550	450	218	24	1123	65	18	69.4
280/B5	5.5	10	19	500	550	450	218	24	1123	75	20	79.9



# Ölçü Sayfaları Dimension Pages Abmessungenseiten



-Mil ucu çekirme deliği DIN 332 sayfa 2 / Tapped center hole to DIN 332, sheet 2 / Zentrierung mit gewinde DIN 332, Blatt 2

KN873.08

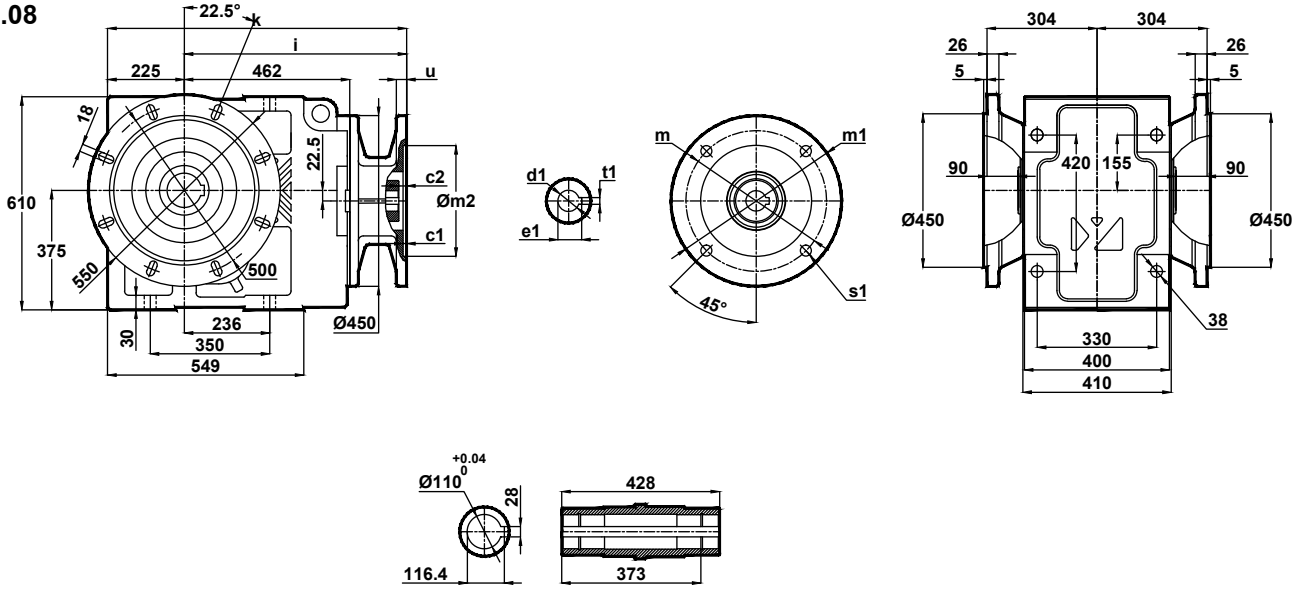

	c1	c2	s1	m	m1	m2	i1	u	k	d1	t1	e1
132/B5	4.5	14	15	265	300	230	218	15	1123	38	10	41.3
160/B5	5.5	10	19	300	350	250	218	20	1123	42	12	45.3
180/B5	5.5	10	19	300	350	250	218	20	1123	48	14	51.8
200/B4	5.5	10	19	350	400	300	218	22	1123	55	16	59.3
225/B5	5.5	10	19	400	450	350	218	24	1123	60	18	64.4
250/B5	5.5	10	19	500	550	450	218	24	1123	65	18	69.4
280/B5	5.5	10	19	500	550	450	218	24	1123	75	20	79.9



# Ölçü Sayfaları

## Dimension Pages

### Abmessungsseiten



-Mil ucu çekirme deliği DIN 332 sayfa 2 / Tapped center hole to DIN 332, sheet 2 / Zentrierung mit gewinde DIN 332, Blatt 2

#### KN874.00

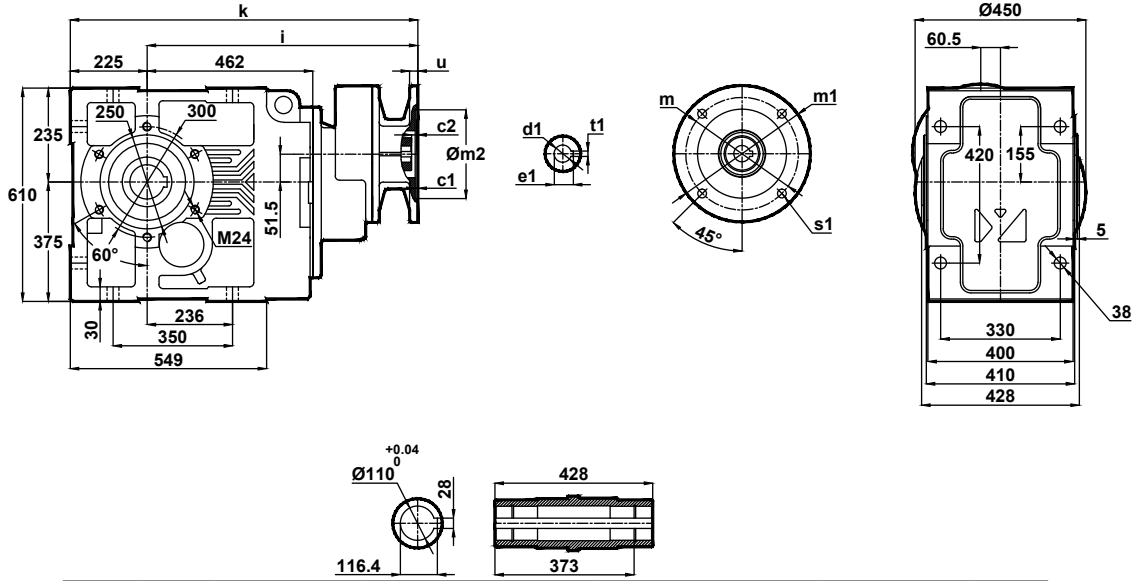

	c1	c2	s1	m	m1	m2	i1	u	k	d1	t1	e1
100/B5	4.5	20	15	215	250	180	653	15	869	28	8	31.3
112/B5	4.5	20	15	215	250	180	653	15	869	28	8	31.3
132/B5	4.5	9	15	265	300	230	674	15	890	38	10	41.3
160/B5	5.5	10	19	300	350	250	749	18	965	42	12	45.3
180/B5	5.5	10	19	300	350	250	749	18	965	48	14	51.8
200/B5	5.5	10	19	350	400	300	769	22	985	55	16	59.3

#### KN874.01

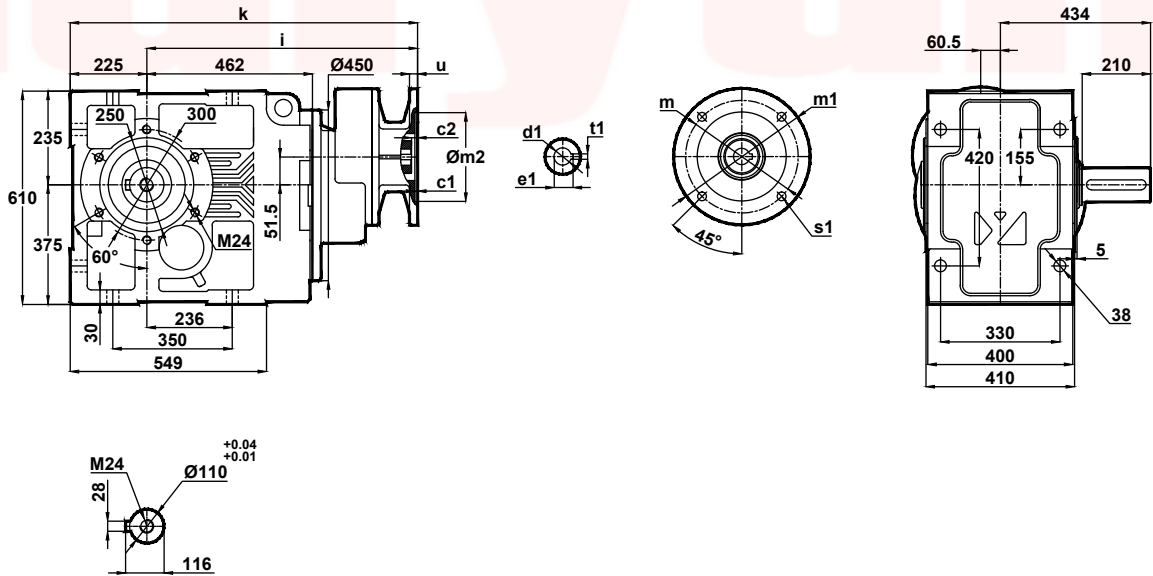

	c1	c2	s1	m	m1	m2	i1	u	k	d1	t1	e1
100/B5	4.5	20	15	215	250	180	653	15	869	28	8	31.3
112/B5	4.5	20	15	215	250	180	653	15	869	28	8	31.3
132/B5	4.5	9	15	265	300	230	674	15	890	38	10	41.3
160/B5	5.5	10	19	300	350	250	749	18	965	42	12	45.3
180/B5	5.5	10	19	300	350	250	749	18	965	48	14	51.8
200/B5	5.5	10	19	350	400	300	769	22	985	55	16	59.3





# Ölçü Sayfaları

## Dimension Pages

### Abmessungsseiten



-Mil ucu çekirme deliği DIN 332 sayfa 2 / Tapped center hole to DIN 332, sheet 2 / Zentrierung mit gewinde DIN 332, Blatt 2

#### KN874.02

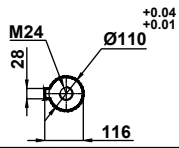
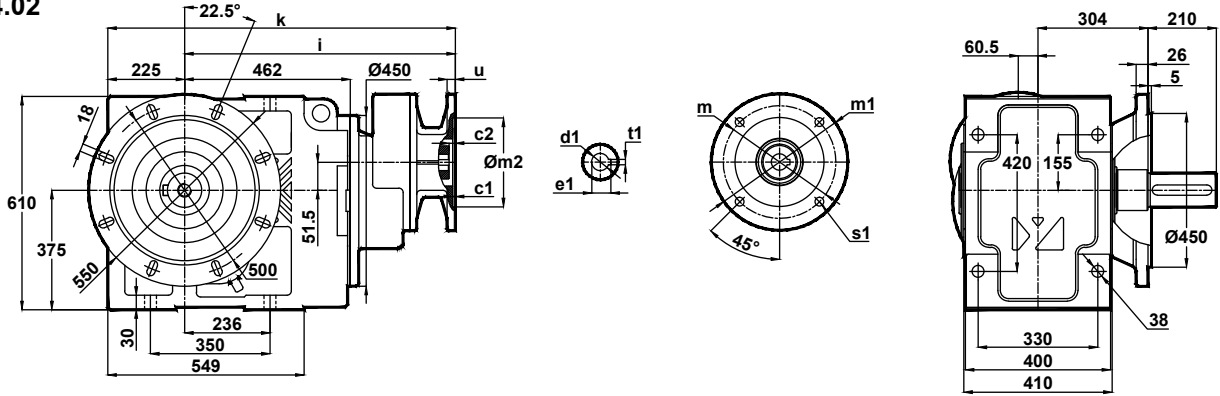

	c1	c2	s1	m	m1	m2	i1	u	k	d1	t1	e1
100/B5	4.5	20	15	215	250	180	653	15	869	28	8	31.3
112/B5	4.5	20	15	215	250	180	653	15	869	28	8	31.3
132/B5	4.5	9	15	265	300	230	674	15	890	38	10	41.3
160/B5	5.5	10	19	300	350	250	749	18	965	42	12	45.3
180/B5	5.5	10	19	300	350	250	749	18	965	48	14	51.8
200/B5	5.5	10	19	350	400	300	769	22	985	55	16	59.3

#### KN874.03

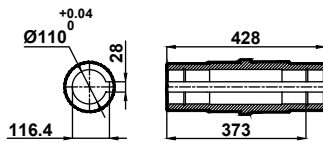
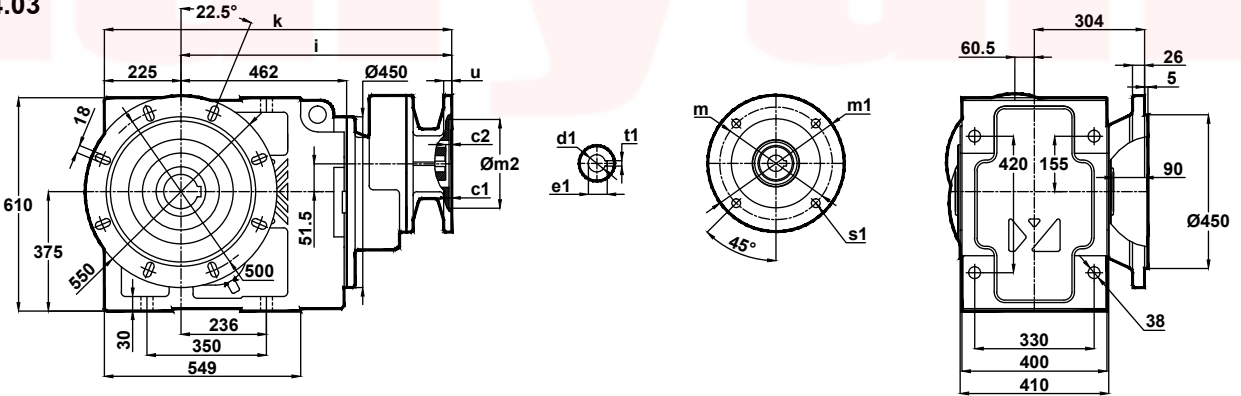

	c1	c2	s1	m	m1	m2	i1	u	k	d1	t1	e1
100/B5	4.5	20	15	215	250	180	653	15	869	28	8	31.3
112/B5	4.5	20	15	215	250	180	653	15	869	28	8	31.3
132/B5	4.5	9	15	265	300	230	674	15	890	38	10	41.3
160/B5	5.5	10	19	300	350	250	749	18	965	42	12	45.3
180/B5	5.5	10	19	300	350	250	749	18	965	48	14	51.8
200/B5	5.5	10	19	350	400	300	769	22	985	55	16	59.3



# Ölçü Sayfaları

## Dimension Pages

### Abmessungsseiten



-Mil ucu çekirme deliği DIN 332 sayfa 2 / Tapped center hole to DIN 332, sheet 2 / Zentrierung mit gewinde DIN 332, Blatt 2

#### KN874.04

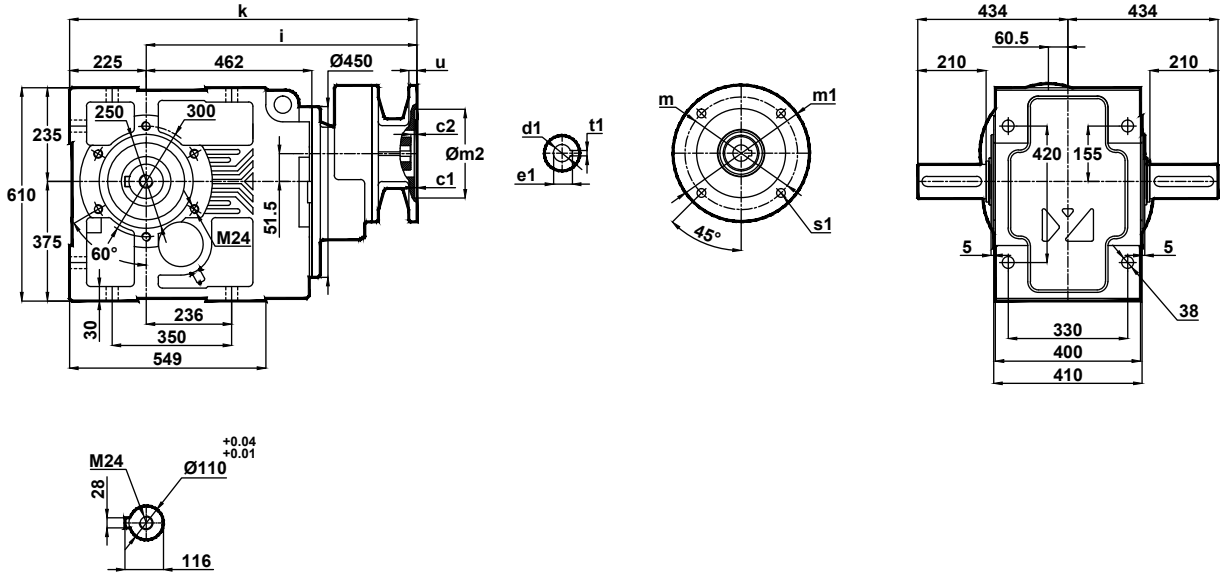

	c1	c2	s1	m	m1	m2	i1	u	k	d1	t1	e1
100/B5	4.5	20	15	215	250	180	653	15	869	28	8	31.3
112/B5	4.5	20	15	215	250	180	653	15	869	28	8	31.3
132/B5	4.5	9	15	265	300	230	674	15	890	38	10	41.3
160/B5	5.5	10	19	300	350	250	749	18	965	42	12	45.3
180/B5	5.5	10	19	300	350	250	749	18	965	48	14	51.8
200/B5	5.5	10	19	350	400	300	769	22	985	55	16	59.3

#### KN874.05

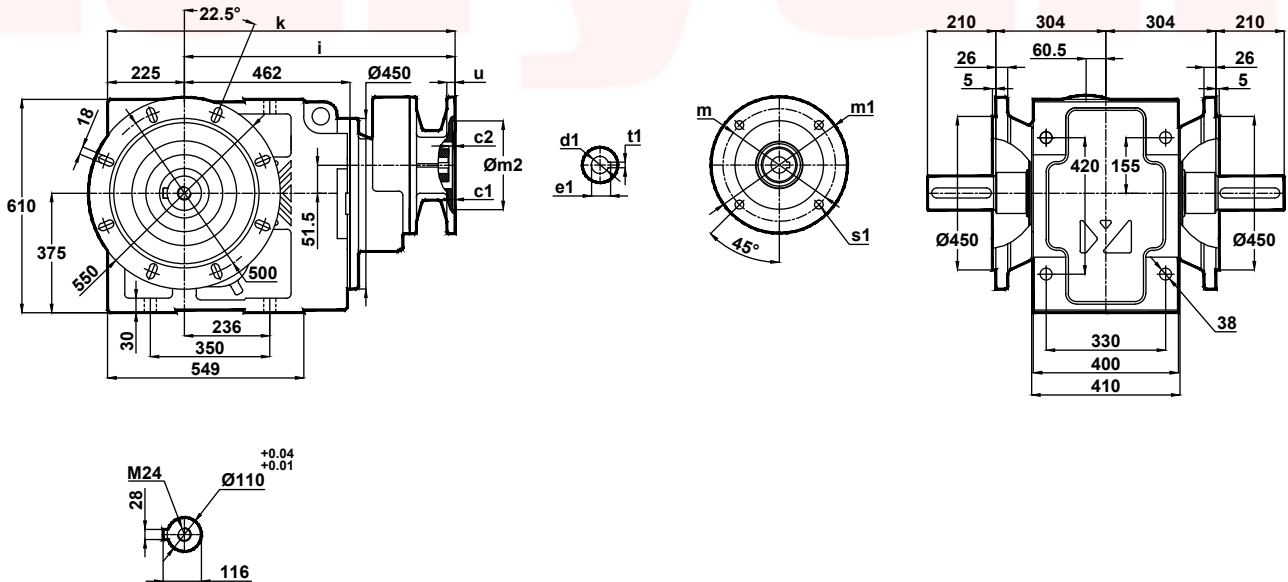

	c1	c2	s1	m	m1	m2	i1	u	k	d1	t1	e1
100/B5	4.5	20	15	215	250	180	653	15	869	28	8	31.3
112/B5	4.5	20	15	215	250	180	653	15	869	28	8	31.3
132/B5	4.5	9	15	265	300	230	674	15	890	38	10	41.3
160/B5	5.5	10	19	300	350	250	749	18	965	42	12	45.3
180/B5	5.5	10	19	300	350	250	749	18	965	48	14	51.8
200/B5	5.5	10	19	350	400	300	769	22	985	55	16	59.3



# Ölçü Sayfaları Dimension Pages Abmessungenseiten



-Mil ucu çekirme deliği DIN 332 sayfa 2 / Tapped center hole to DIN 332, sheet 2 / Zentrierung mit gewinde DIN 332, Blatt 2

KN874.08

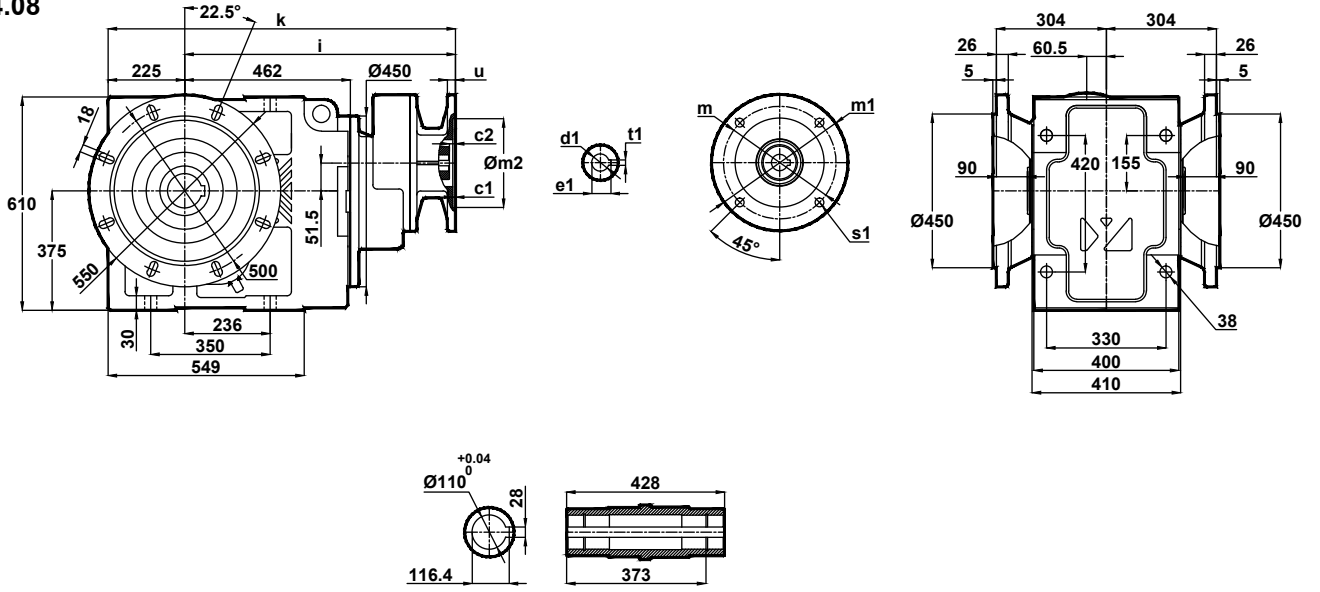

	c1	c2	s1	m	m1	m2	i1	u	k	d1	t1	e1
100/B5	4.5	20	15	215	250	180	653	15	869	28	8	31.3
112/B5	4.5	20	15	215	250	180	653	15	869	28	8	31.3
132/B5	4.5	9	15	265	300	230	674	15	890	38	10	41.3
160/B5	5.5	10	19	300	350	250	749	18	965	42	12	45.3
180/B5	5.5	10	19	300	350	250	749	18	965	48	14	51.8
200/B5	5.5	10	19	350	400	300	769	22	985	55	16	59.3



# Ölçü Sayfaları

## Dimension Pages

### Abmessungsseiten



-Mil ucu çekirme deliği DIN 332 sayfa 2 / Tapped center hole to DIN 332, sheet 2 / Zentrierung mit gewinde DIN 332, Blatt 2

KN875.00  
KN876.00

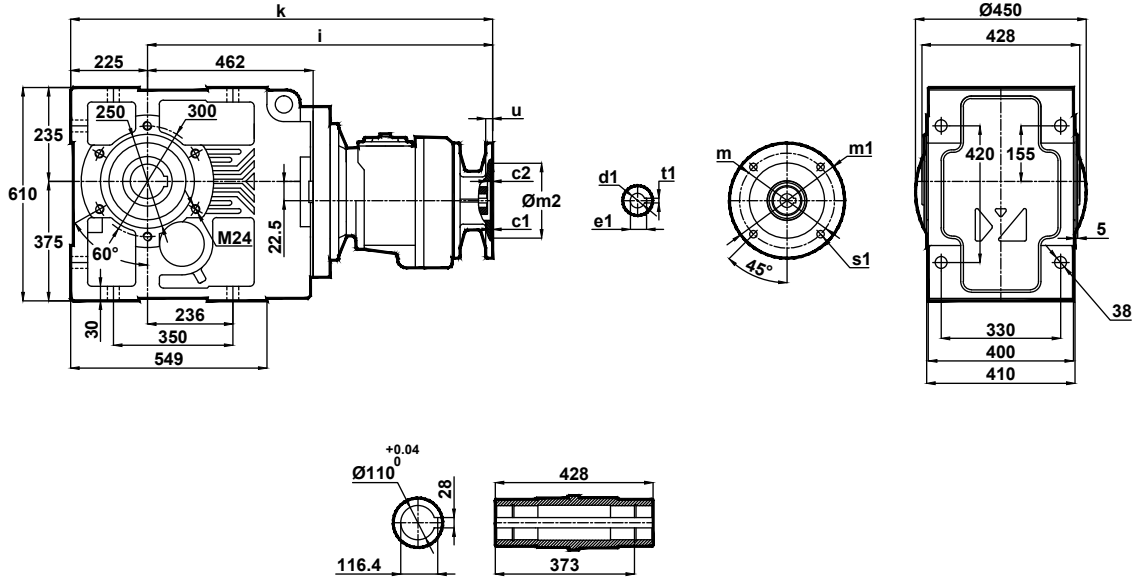

	c1	c2	s1	m	m1	m2	i1	u	k	d1	t1	e1
71/B5	4	9	11	130	160	110	772	12	997	14	5	16.3
80/B5	4	9	13	165	200	130	772	12	997	19	6	21.8
90/B5	4	9	13	165	200	130	772	12	997	24	8	27.3
100/B5	4.5	9	15	215	250	180	789	15	1014	28	8	31.3
112/B5	4.5	9	15	215	250	180	789	15	1014	28	8	31.3
132/B5	4.5	7	15	265	300	230	809	15	1034	38	10	41.3

KN875.01  
KN876.01

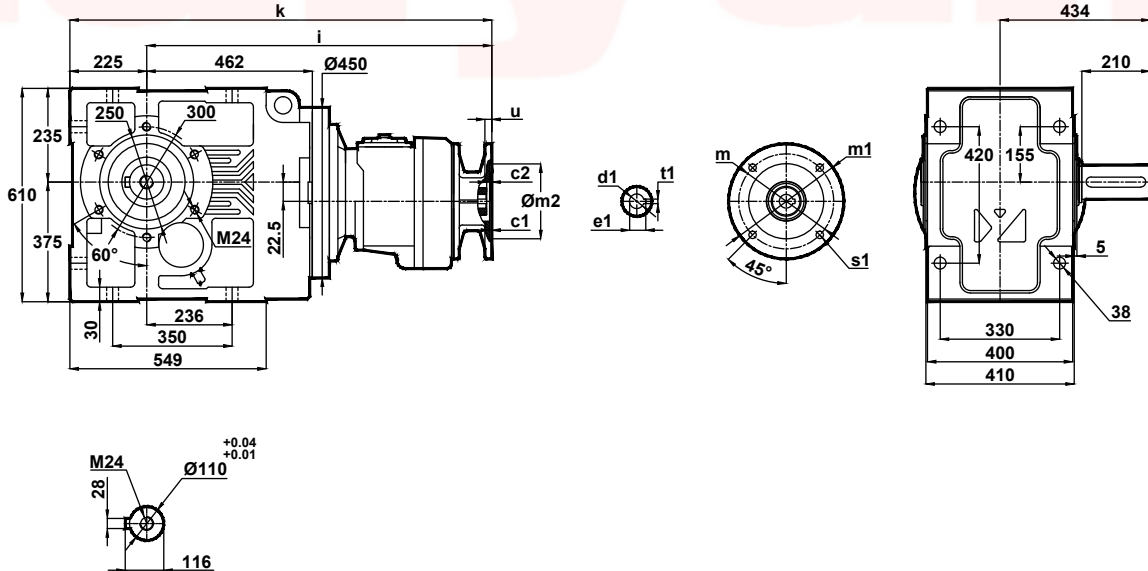

	c1	c2	s1	m	m1	m2	i1	u	k	d1	t1	e1
71/B5	4	9	11	130	160	110	772	12	997	14	5	16.3
80/B5	4	9	13	165	200	130	772	12	997	19	6	21.8
90/B5	4	9	13	165	200	130	772	12	997	24	8	27.3
100/B5	4.5	9	15	215	250	180	789	15	1014	28	8	31.3
112/B5	4.5	9	15	215	250	180	789	15	1014	28	8	31.3
132/B5	4.5	7	15	265	300	230	809	15	1034	38	10	41.3



# Ölçü Sayfaları Dimension Pages Abmessungenseiten



-Mil ucu çekirme deliği DIN 332 sayfa 2 / Tapped center hole to DIN 332, sheet 2 / Zentrierung mit gewinde DIN 332, Blatt 2

KN875.02  
KN876.02

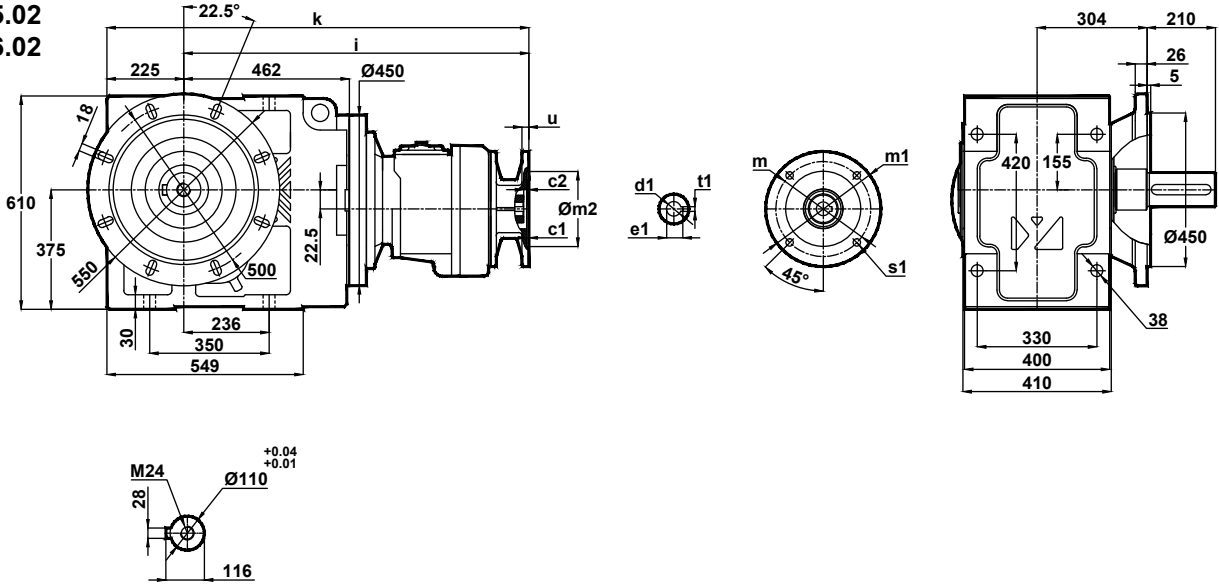

	c1	c2	s1	m	m1	m2	i1	u	k	d1	t1	e1
71/B5	4	9	11	130	160	110	772	12	997	14	5	16.3
80/B5	4	9	13	165	200	130	772	12	997	19	6	21.8
90/B5	4	9	13	165	200	130	772	12	997	24	8	27.3
100/B5	4.5	9	15	215	250	180	789	15	1014	28	8	31.3
112/B5	4.5	9	15	215	250	180	789	15	1014	28	8	31.3
132/B5	4.5	7	15	265	300	230	809	15	1034	38	10	41.3

KN875.03  
KN876.03

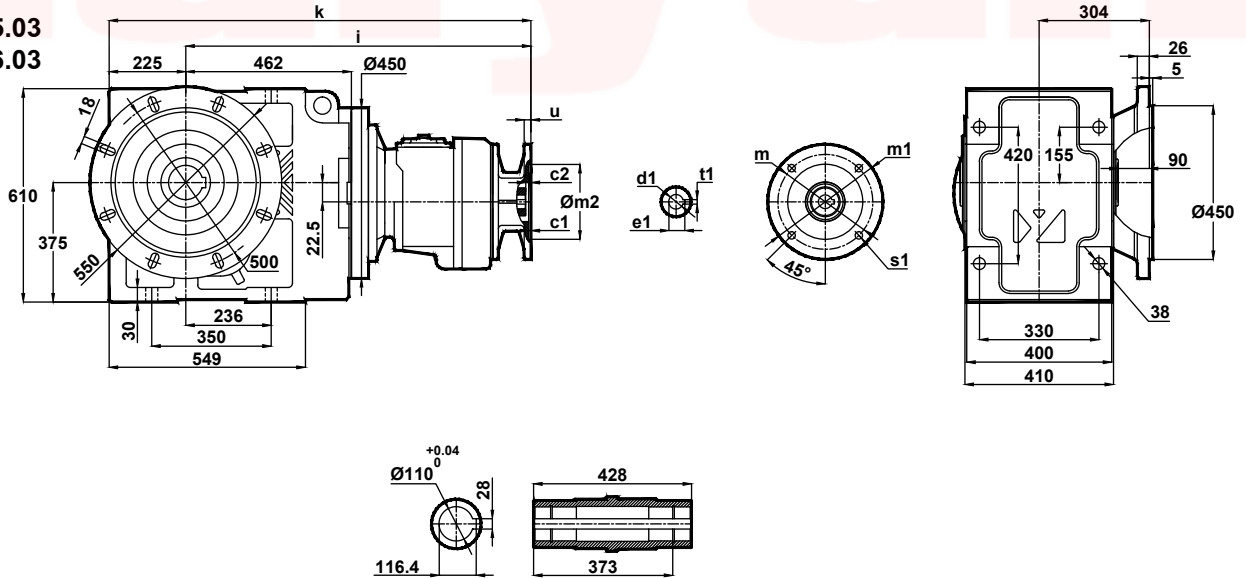

	c1	c2	s1	m	m1	m2	i1	u	k	d1	t1	e1
71/B5	4	9	11	130	160	110	772	12	997	14	5	16.3
80/B5	4	9	13	165	200	130	772	12	997	19	6	21.8
90/B5	4	9	13	165	200	130	772	12	997	24	8	27.3
100/B5	4.5	9	15	215	250	180	789	15	1014	28	8	31.3
112/B5	4.5	9	15	215	250	180	789	15	1014	28	8	31.3
132/B5	4.5	7	15	265	300	230	809	15	1034	38	10	41.3



# Ölçü Sayfaları

## Dimension Pages

### Abmessungsseiten



-Mil ucu çekirme deliği DIN 332 sayfa 2 / Tapped center hole to DIN 332, sheet 2 / Zentrierung mit gewinde DIN 332, Blatt 2

KN875.04  
KN876.04

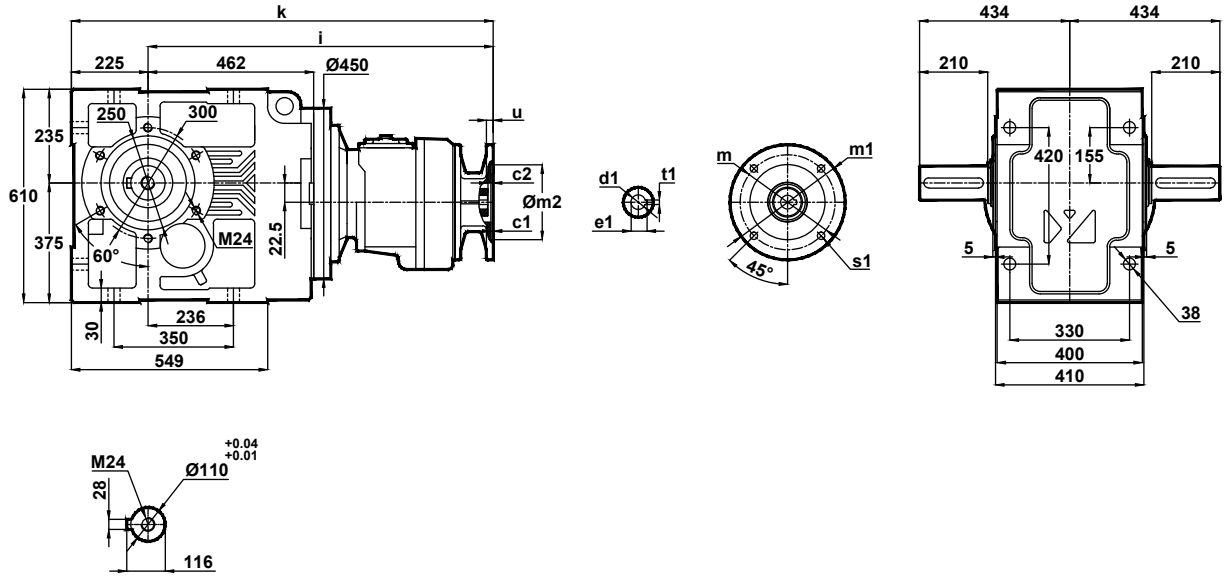

	c1	c2	s1	m	m1	m2	i1	u	k	d1	t1	e1
71/B5	4	9	11	130	160	110	772	12	997	14	5	16.3
80/B5	4	9	13	165	200	130	772	12	997	19	6	21.8
90/B5	4	9	13	165	200	130	772	12	997	24	8	27.3
100/B5	4.5	9	15	215	250	180	789	15	1014	28	8	31.3
112/B5	4.5	9	15	215	250	180	789	15	1014	28	8	31.3
132/B5	4.5	7	15	265	300	230	809	15	1034	38	10	41.3

KN875.05  
KN876.05

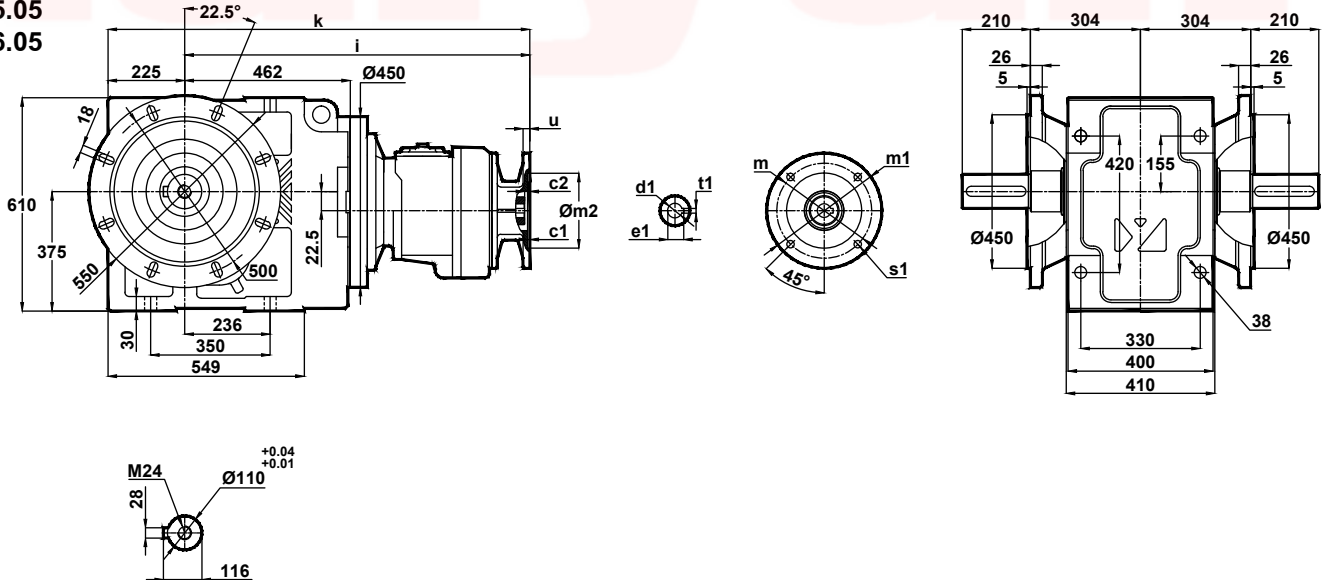

	c1	c2	s1	m	m1	m2	i1	u	k	d1	t1	e1
71/B5	4	9	11	130	160	110	772	12	997	14	5	16.3
80/B5	4	9	13	165	200	130	772	12	997	19	6	21.8
90/B5	4	9	13	165	200	130	772	12	997	24	8	27.3
100/B5	4.5	9	15	215	250	180	789	15	1014	28	8	31.3
112/B5	4.5	9	15	215	250	180	789	15	1014	28	8	31.3
132/B5	4.5	7	15	265	300	230	809	15	1034	38	10	41.3



# Ölçü Sayfaları Dimension Pages Abmessungenseiten



-Mil ucu çekirme deliği DIN 332 sayfa 2 / Tapped center hole to DIN 332, sheet 2 / Zentrierung mit gewinde DIN 332, Blatt 2

KN875.08  
KN876.08

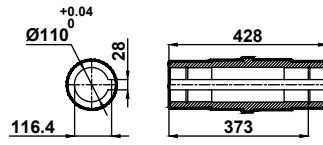
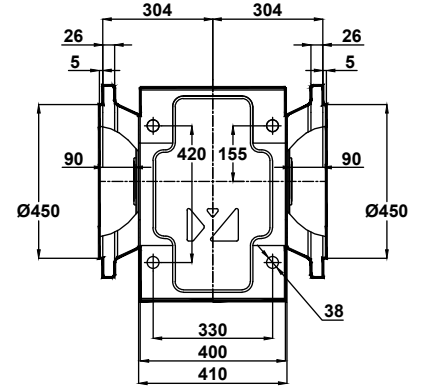
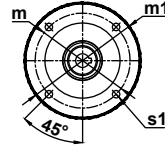
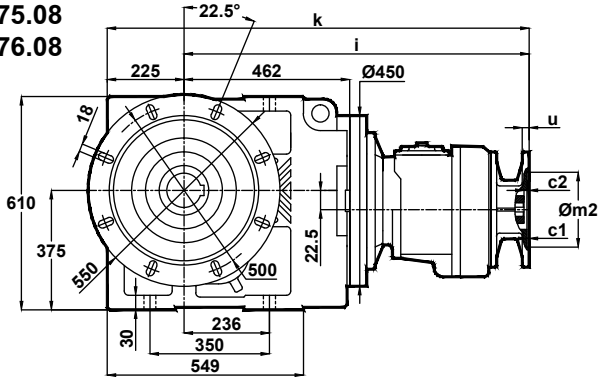

	c1	c2	s1	m	m1	m2	i1	u	k	d1	t1	e1
71/B5	4	9	11	130	160	110	772	12	997	14	5	16.3
80/B5	4	9	13	165	200	130	772	12	997	19	6	21.8
90/B5	4	9	13	165	200	130	772	12	997	24	8	27.3
100/B5	4.5	9	15	215	250	180	789	15	1014	28	8	31.3
112/B5	4.5	9	15	215	250	180	789	15	1014	28	8	31.3
132/B5	4.5	7	15	265	300	230	809	15	1034	38	10	41.3



# Ölçü Sayfaları Dimension Pages Abmessungsseiten



-Mil ucu çekirme deliği DIN 332 sayfa 2 / Tapped center hole to DIN 332, sheet 2 / Zentrierung mit gewinde DIN 332, Blatt 2

## KV273.00

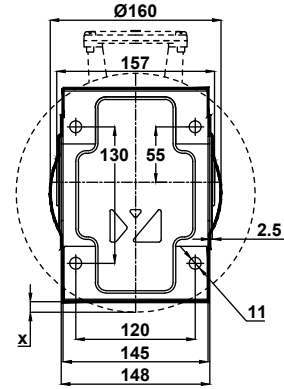
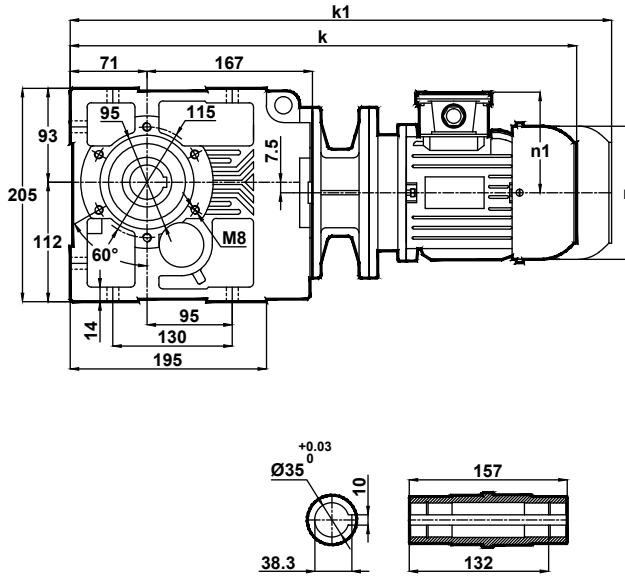

x: Motor Ayak bağlantı yüzeyinin altında ise  
x: If Motor is lower than foot mounting plane  
x: Wenn motor ist niedriger den die Anschlußplatte

**Klemens Pozisyonları**  
Terminal Box Positions  
Klemmenkasten Positionen

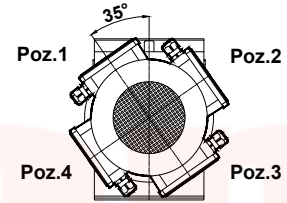

63-71-80-90-100-112  
Tip / Type / Typ

	63/B5	71/B5	80/B5	90S/B5	90L/B5	100L/B5	112M/B5
k	505	502	551	571	596	621	641
k1	-	622	671	696	721	756	776
n	116	138	156	176	176	194	218
n1	97	110	118	126	126	135	146
x	-	-	-	-	-	-	4.5

## KV273.01

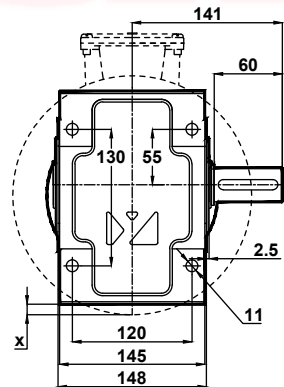
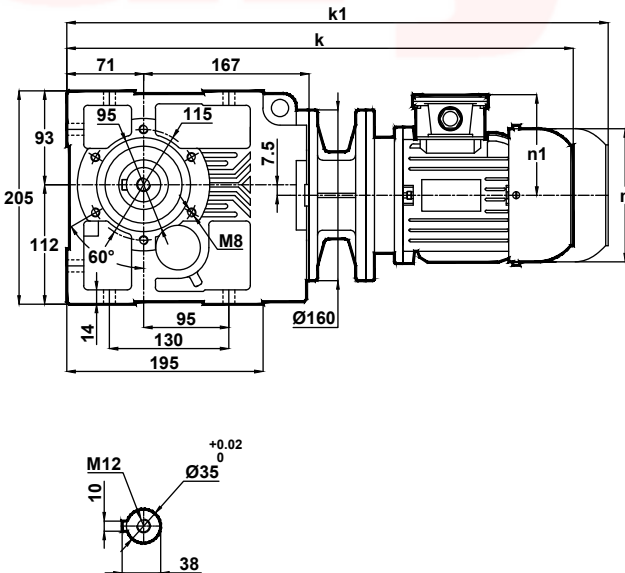

x: Motor Ayak bağlantı yüzeyinin altında ise  
x: If Motor is lower than foot mounting plane  
x: Wenn motor ist niedriger den die Anschlußplatte

	63/B5	71/B5	80/B5	90S/B5	90L/B5	100L/B5	112M/B5
k	505	502	551	571	596	621	641
k1	-	622	671	696	721	756	776
n	116	138	156	176	176	194	218
n1	97	110	118	126	126	135	146
x	-	-	-	-	-	-	4.5





# Ölçü Sayfaları Dimension Pages Abmessungsseiten



-Mil ucu çekirme deliği DIN 332 sayfa 2 / Tapped center hole to DIN 332, sheet 2 / Zentrierung mit gewinde DIN 332, Blatt 2

## KV273.02

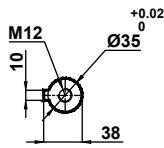
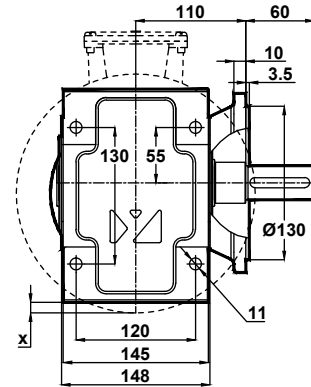
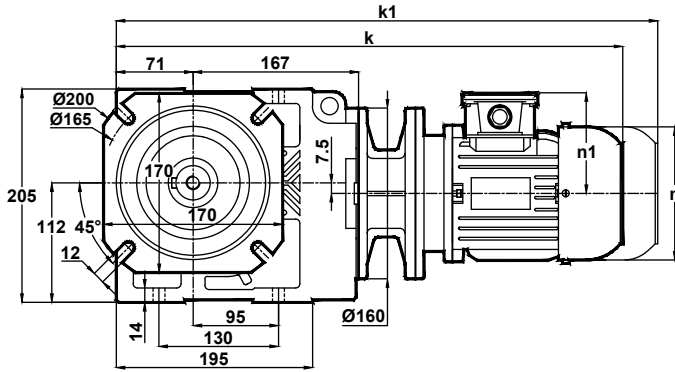

x: Motor Ayak bağlantı yüzeyinin altında ise  
x: If Motor is lower then foot mounting plane  
x:Wen motor ist nidriger den die Anschlußplatte

Klemens Pozisyonları  
Terminal Box Positions  
Klemmenkasten Positionen

	63/B5	71/B5	80/B5	90S/B5	90L/B5	100L/B5	112M/B5
k	505	502	551	571	596	621	641
k1	-	622	671	696	721	756	776
n	116	138	156	176	176	194	218
n1	97	110	118	126	126	135	146
x	-	-	-	-	-	-	4.5

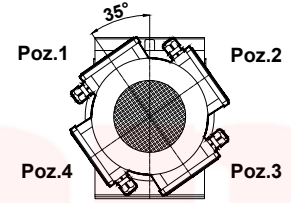

63-80-90-100-112  
Tip / Type / Typ

## KV273.03

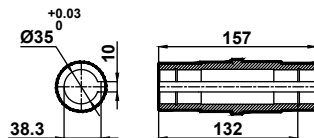
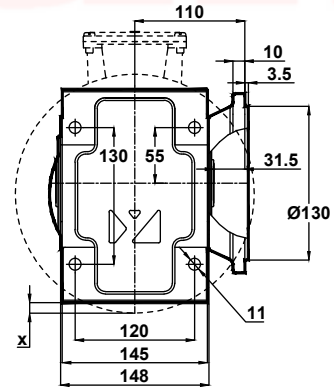
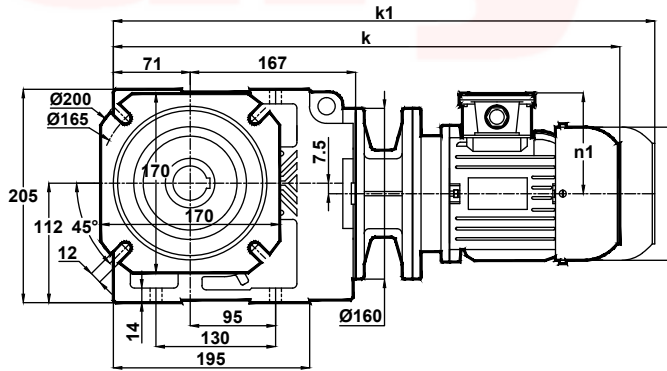

x: Motor Ayak bağlantı yüzeyinin altında ise  
x: If Motor is lower then foot mounting plane  
x:Wen motor ist nidriger den die Anschlußplatte

	63/B5	71/B5	80/B5	90S/B5	90L/B5	100L/B5	112M/B5
k	505	502	551	571	596	621	641
k1	-	622	671	696	721	756	776
n	116	138	156	176	176	194	218
n1	97	110	118	126	126	135	146
x	-	-	-	-	-	-	4.5



# Ölçü Sayfaları Dimension Pages Abmessungsseiten



-Mil ucu çekirme deliği DIN 332 sayfa 2 / Tapped center hole to DIN 332, sheet 2 / Zentrierung mit gewinde DIN 332, Blatt 2

## KV273.04

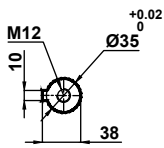
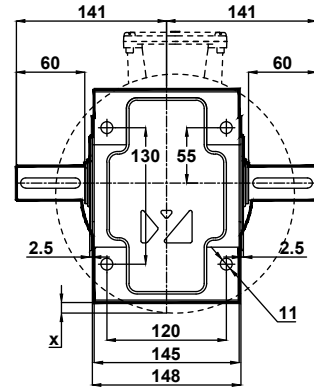
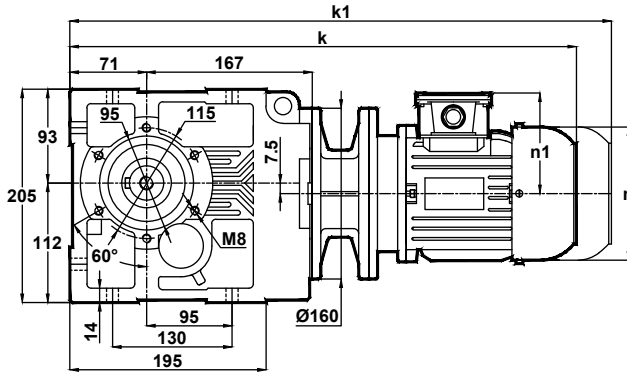

x: Motor Ayak bağlantı yüzeyinin altında ise  
x: If Motor is lower then foot mounting plane  
x: Wenn motor ist niedriger den die Anschlußplatte

	63/B5	71/B5	80/B5	90S/B5	90L/B5	100L/B5	112M/B5
k	505	502	551	571	596	621	641
k1	-	622	671	696	721	756	776
n	116	138	156	176	176	194	218
n1	97	110	118	126	126	135	146
x	-	-	-	-	-	-	4.5

Klemens Pozisyonları  
Terminal Box Positions  
Klemmenkasten Positionen

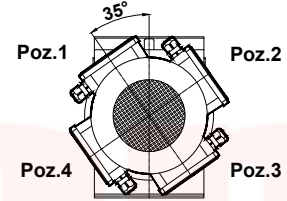

63-71-80-90-100-112  
Tip / Type / Typ

## KV273.05

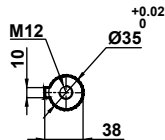
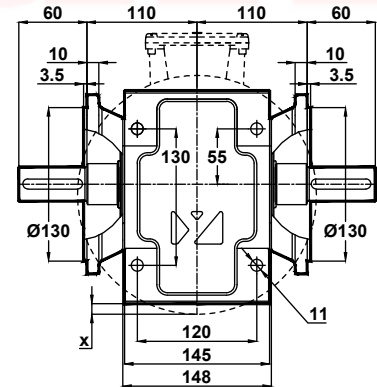
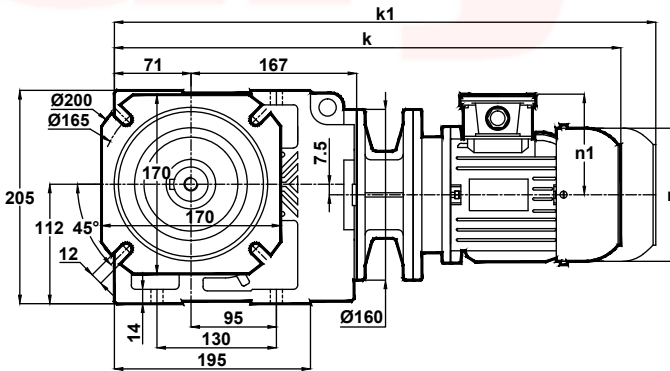

x: Motor Ayak bağlantı yüzeyinin altında ise  
x: If Motor is lower then foot mounting plane  
x: Wenn motor ist niedriger den die Anschlußplatte

	63/B5	71/B5	80/B5	90S/B5	90L/B5	100L/B5	112M/B5
k	505	502	551	571	596	621	641
k1	-	622	671	696	721	756	776
n	116	138	156	176	176	194	218
n1	97	110	118	126	126	135	146
x	-	-	-	-	-	-	4.5



# Ölçü Sayfaları Dimension Pages Abmessungsseiten



-Mil ucu çektirme deliği DIN 332 sayfa 2 / Tapped center hole to DIN 332, sheet 2 / Zentrierung mit gewinde DIN 332, Blatt 2

KV273.08

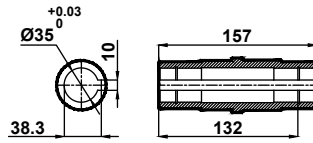
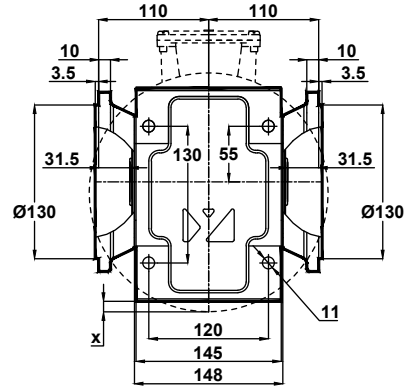
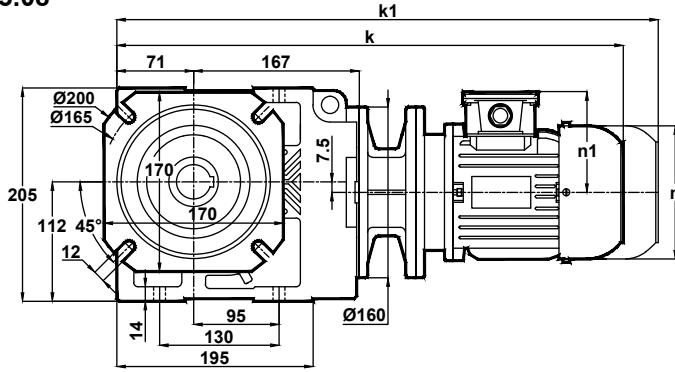

x: Motor ayak bağlantı yüzeyinin altında ise  
x: If Motor is lower then foot mounting plane  
x: Wenn motor ist niedriger den die Anschlußplatte

Klemens Pozisyonları  
Terminal Box Positions  
Klemmenkasten Positionen

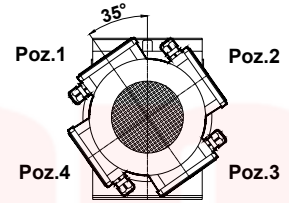

63-71-80-90-100-112  
Tip / Type / Typ

	63/B5	71/B5	80/B5	90S/B5	90L/B5	100L/B5	112M/B5
k	505	502	551	571	596	621	641
k1	-	622	671	696	721	756	776
n	116	138	156	176	176	194	218
n1	97	110	118	126	126	135	146
x	-	-	-	-	-	-	4.5



# Ölçü Sayfaları Dimension Pages Abmessungenseiten



-Mil ucu çektirme deliği DIN 332 sayfa 2 / Tapped center hole to DIN 332, sheet 2 / Zentrierung mit gewinde DIN 332, Blatt 2

KV275.00  
KV276.00

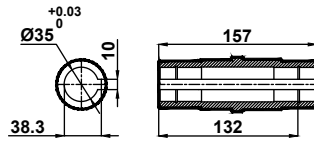
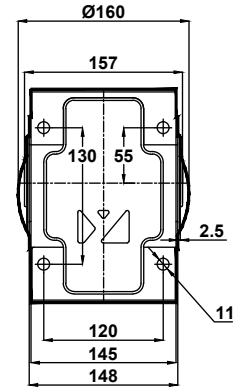
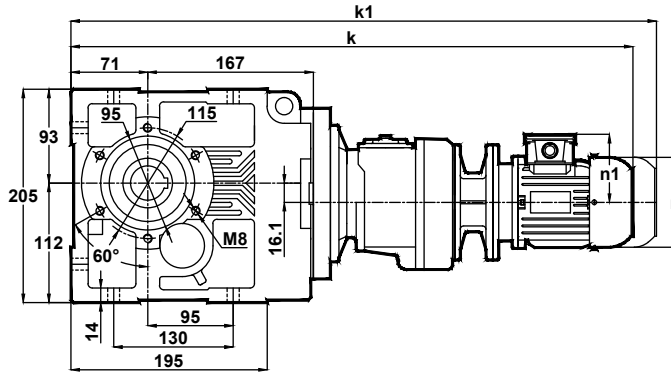

	63/B5	71/B5	80/B5	90S/B5	90L/B5
k	620	648	683	703	728
k1	-	768	803	828	853
n	116	138	156	176	176
n1	97	110	118	126	126

Klemens Pozisyonları  
Terminal Box Positions  
Klemmenkasten Positionen

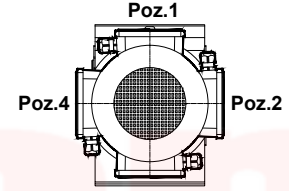

Poz.3  
63-71-80-90  
Tip / Type / Typ

KV275.01  
KV276.01

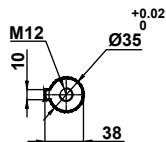
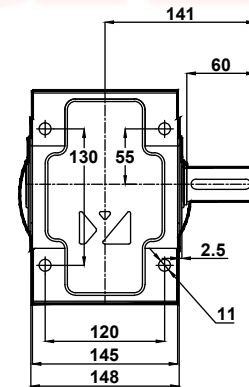
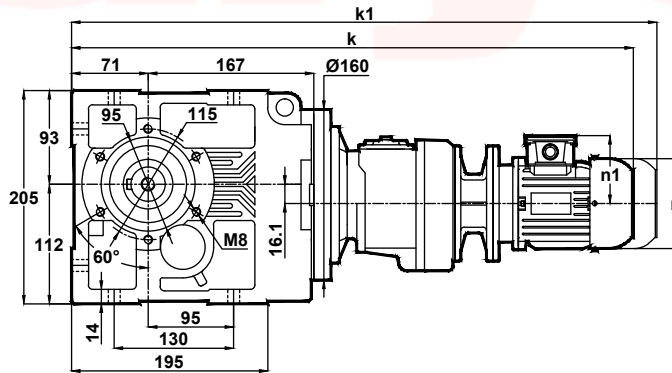

	63/B5	71/B5	80/B5	90S/B5	90L/B5
k	620	648	683	703	728
k1	-	768	803	828	853
n	116	138	156	176	176
n1	97	110	118	126	126



# Ölçü Sayfaları Dimension Pages Abmessungsseiten



-Mil ucu çekirme deliği DIN 332 sayfa 2 / Tapped center hole to DIN 332, sheet 2 / Zentrierung mit gewinde DIN 332, Blatt 2

KV275.02  
KV276.02

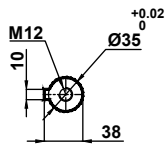
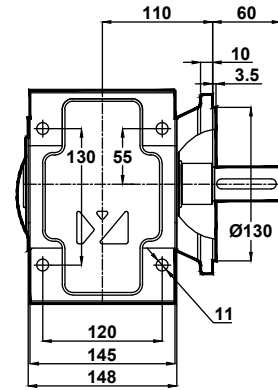
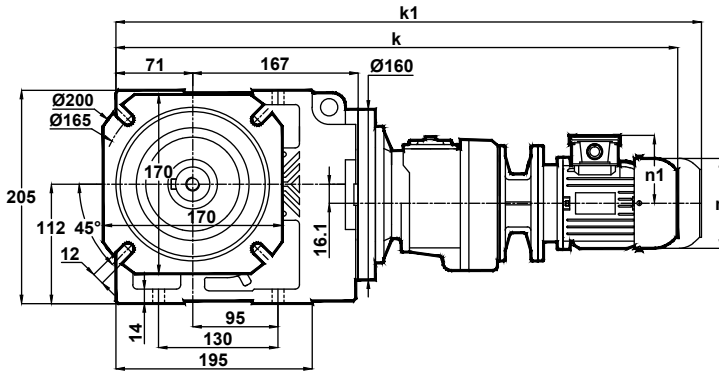

	63/B5	71/B5	80/B5	90S/B5	90L/B5
k	620	648	683	703	728
k1	-	768	803	828	853
n	116	138	156	176	176
n1	97	110	118	126	126

Klemens Pozisyonları  
Terminal Box Positions  
Klemmenkasten Positionen

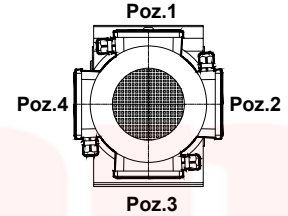

63-71-80-90  
Tip / Type / Typ

KV275.03  
KV276.03

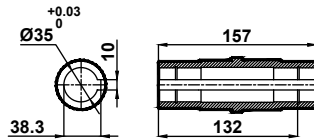
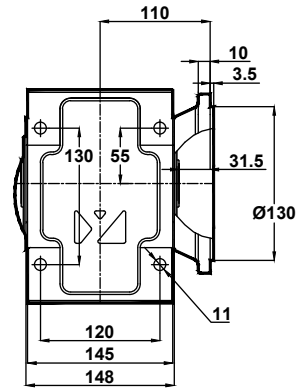
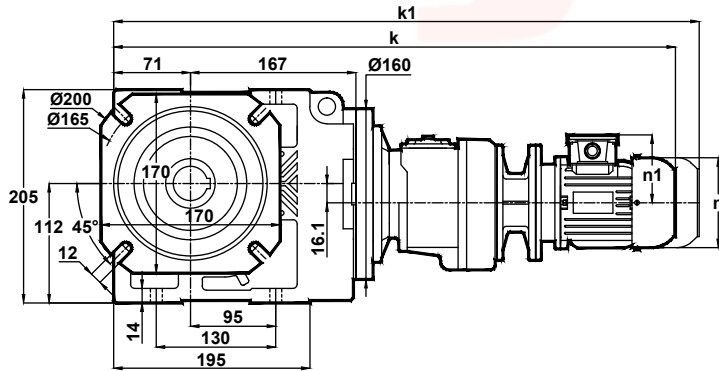

	63/B5	71/B5	80/B5	90S/B5	90L/B5
k	620	648	683	703	728
k1	-	768	803	828	853
n	116	138	156	176	176
n1	97	110	118	126	126



# Ölçü Sayfaları Dimension Pages Abmessungsseiten



-Mil ucu çektirme deliği DIN 332 sayfa 2 / Tapped center hole to DIN 332, sheet 2 / Zentrierung mit gewinde DIN 332, Blatt 2

KV275.04  
KV276.04

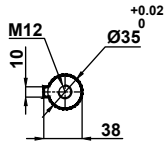
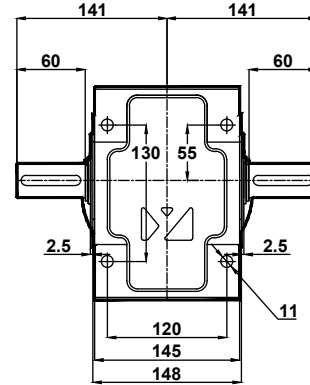
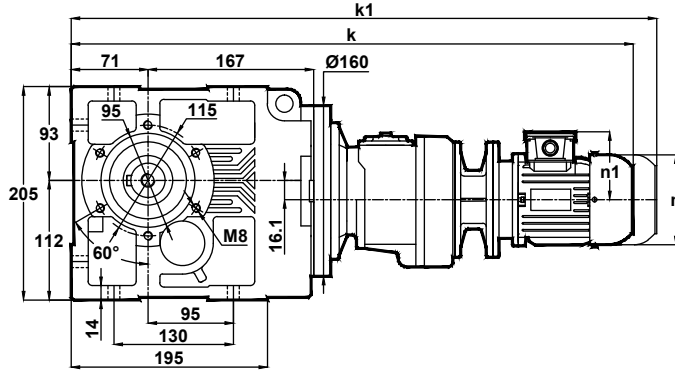

	63/B5	71/B5	80/B5	90S/B5	90L/B5
k	620	648	683	703	728
k1	-	768	803	828	853
n	116	138	156	176	176
n1	97	110	118	126	126

Klemens Pozisyonları  
Terminal Box Positions  
Klemmenkasten Positionen

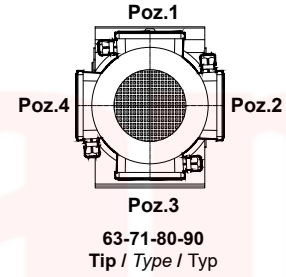

KV275.05  
KV276.05

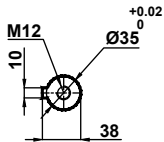
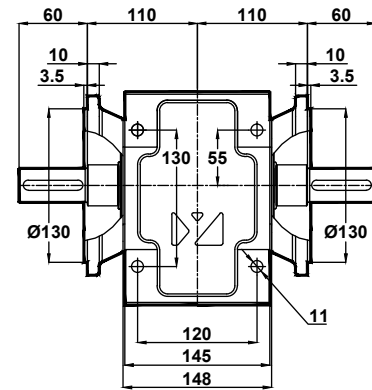
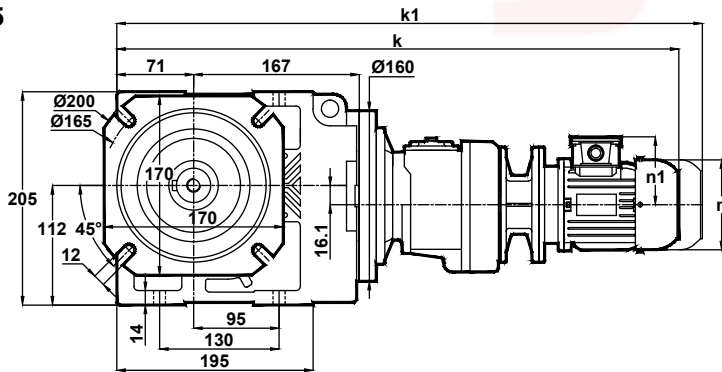

	63/B5	71/B5	80/B5	90S/B5	90L/B5
k	620	648	683	703	728
k1	-	768	803	828	853
n	116	138	156	176	176
n1	97	110	118	126	126



# Ölçü Sayfaları Dimension Pages Abmessungsseiten



-Mil ucu çekirme deliği DIN 332 sayfa 2 / Tapped center hole to DIN 332, sheet 2 / Zentrierung mit gewinde DIN 332, Blatt 2

KV275.08  
KV276.08

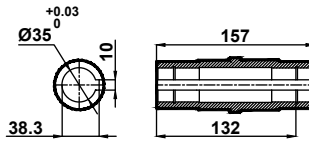
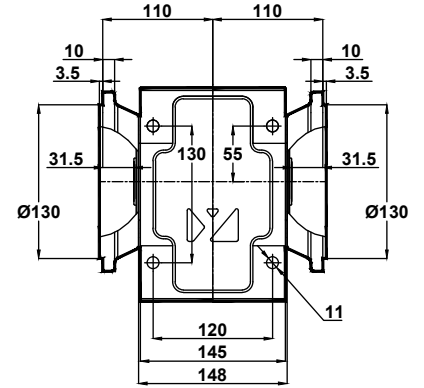
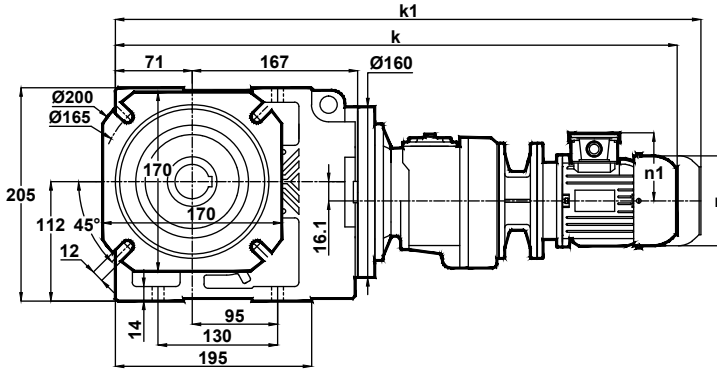

	63/B5	71/B5	80/B5	90S/B5	90L/B5
k	620	648	683	703	728
k1	-	768	803	828	853
n	116	138	156	176	176
n1	97	110	118	126	126

Klemens Pozisyonları  
Terminal Box Positions  
Klemmenkasten Positionen

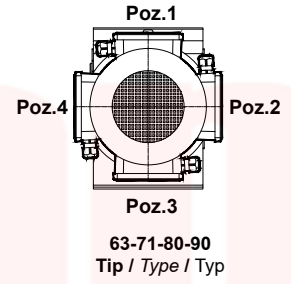



# Ölçü Sayfaları Dimension Pages Abmessungsseiten



-Mil ucu çekirme deliği DIN 332 sayfa 2 / Tapped center hole to DIN 332, sheet 2 / Zentrierung mit gewinde DIN 332, Blatt 2

## KV373.00

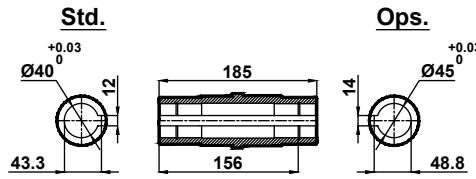
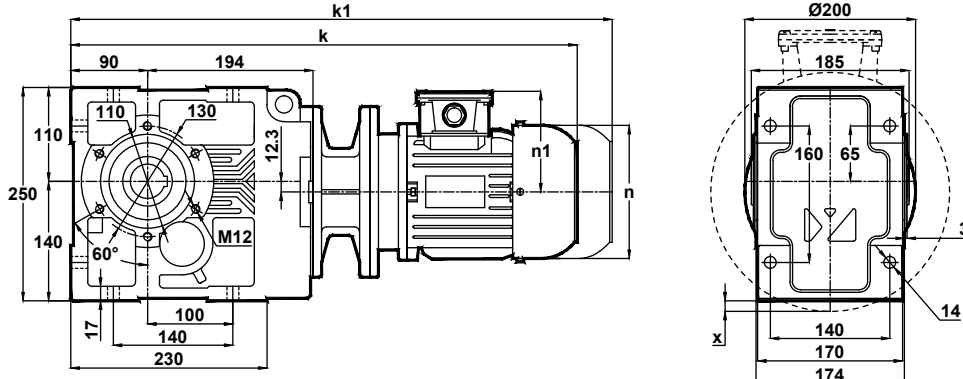

x: Motor Ayak bağlantı yüzeyinin altında ise  
x: If Motor is lower then foot mounting plane  
x: Wenn motor ist niedriger den die Anschlußplatte

**Klemens Pozisyonları**  
Terminal Box Positions  
Klemmenkasten Positionen

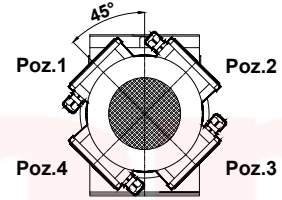

71-80-90-100-112-132  
Tip / Type / Typ

	71/B5	80/B5	90S/B5	90L/B5	100L/B5	112M/B5	132S/B5	132M/B5
k	570	590	610	635	684	704	768	806
k1	690	710	735	760	819	839	913	951
n	138	156	176	176	194	218	258	258
n1	110	118	126	126	135	146	168	168
x	-	-	-	-	-	-	1.3	1.3

## KV373.01

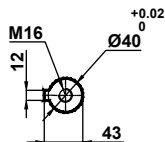
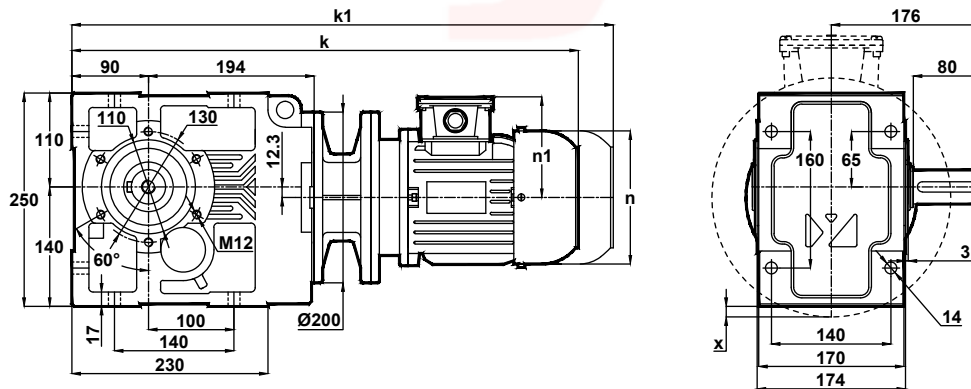

x: Motor Ayak bağlantı yüzeyinin altında ise  
x: If Motor is lower then foot mounting plane  
x: Wenn motor ist niedriger den die Anschlußplatte

	71/B5	80/B5	90S/B5	90L/B5	100L/B5	112M/B5	132S/B5	132M/B5
k	570	590	610	635	684	704	768	806
k1	690	710	735	760	819	839	913	951
n	138	156	176	176	194	218	258	258
n1	110	118	126	126	135	146	168	168
x	-	-	-	-	-	-	1.3	1.3





# Ölçü Sayfaları Dimension Pages Abmessungsseiten



-Mil ucu çektirme deliği DIN 332 sayfa 2 / Tapped center hole to DIN 332, sheet 2 / Zentrierung mit gewinde DIN 332, Blatt 2

## KV373.02

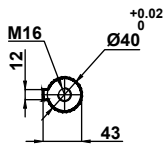
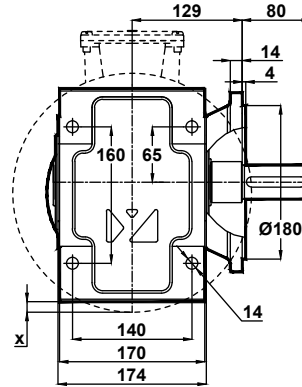
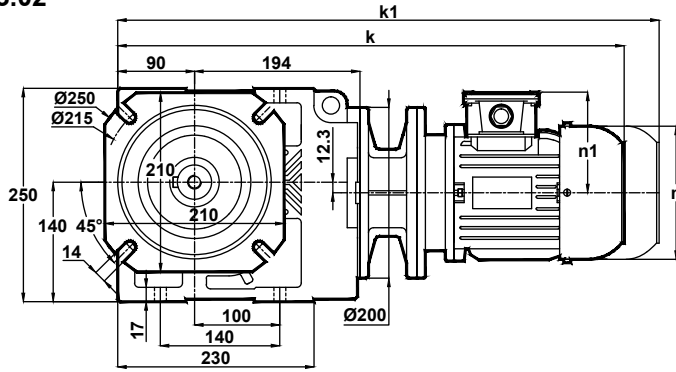

x: Motor Ayak bağlantı yüzeyinin altında ise  
x: If Motor is lower then foot mounting plane  
x:Wen motor ist nidriger den die Anschlußplatte

Klemens Pozisyonları  
Terminal Box Positions  
Klemmenkasten Positionen

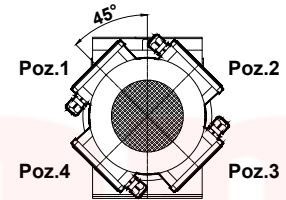

71-80-90-100-112-132  
Tip / Type / Typ

	71/B5	80/B5	90S/B5	90L/B5	100L/B5	112M/B5	132S/B5	132M/B5
k	570	590	610	635	684	704	768	806
k1	690	710	735	760	819	839	913	951
n	138	156	176	176	194	218	258	258
n1	110	118	126	126	135	146	168	168
x	-	-	-	-	-	-	1.3	1.3

## KV373.03

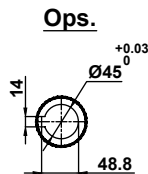
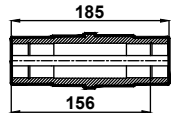
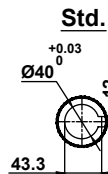
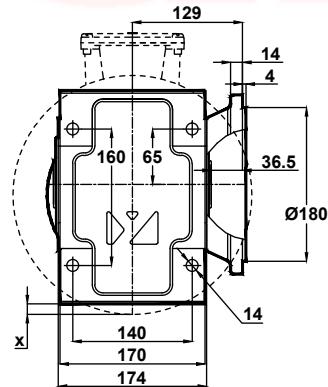
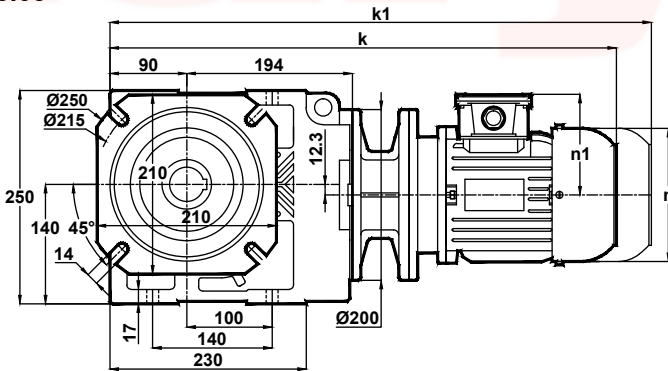

x: Motor Ayak bağlantı yüzeyinin altında ise  
x: If Motor is lower then foot mounting plane  
x:Wen motor ist nidriger den die Anschlußplatte

	71/B5	80/B5	90S/B5	90L/B5	100L/B5	112M/B5	132S/B5	132M/B5
k	570	590	610	635	684	704	768	806
k1	690	710	735	760	819	839	913	951
n	138	156	176	176	194	218	258	258
n1	110	118	126	126	135	146	168	168
x	-	-	-	-	-	-	1.3	1.3



# Ölçü Sayfaları Dimension Pages Abmessungsseiten



-Mil ucu çektirme deliği DIN 332 sayfa 2 / Tapped center hole to DIN 332, sheet 2 / Zentrierung mit gewinde DIN 332, Blatt 2

## KV373.04

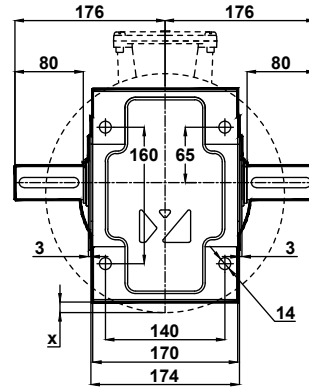
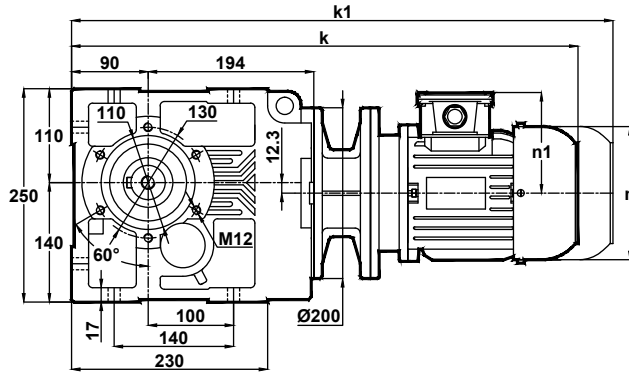

x: Motor Ayak bağlantı yüzeyinin altında ise  
x: If Motor is lower then foot mounting plane  
x: Wenn motor ist niedriger den die Anschlußplatte

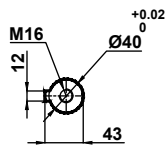

Klemens Pozisyonları  
Terminal Box Positions  
Klemmenkasten Positionen

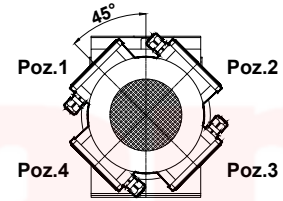

71-80-90-100-112-132  
Tip / Type / Typ

	71/B5	80/B5	90S/B5	90L/B5	100L/B5	112M/B5	132S/B5	132M/B5
k	570	590	610	635	684	704	768	806
k1	690	710	735	760	819	839	913	951
n	138	156	176	176	194	218	258	258
n1	110	118	126	126	135	146	168	168
x	-	-	-	-	-	-	1.3	1.3

## KV373.05

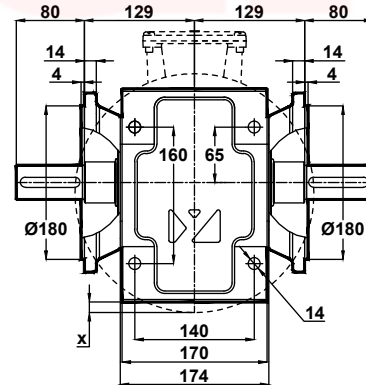
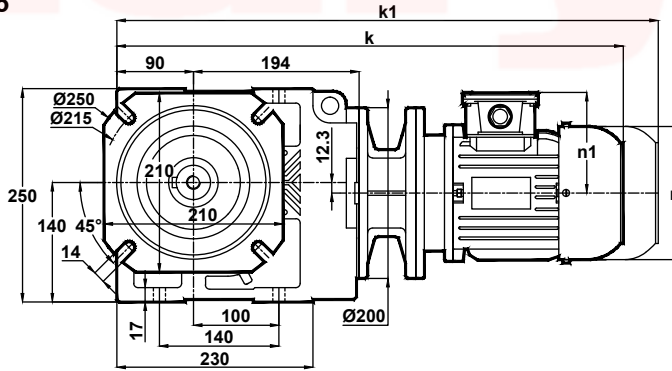

x: Motor Ayak bağlantı yüzeyinin altında ise  
x: If Motor is lower then foot mounting plane  
x: Wenn motor ist niedriger den die Anschlußplatte

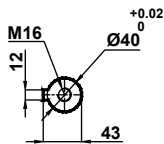

	71/B5	80/B5	90S/B5	90L/B5	100L/B5	112M/B5	132S/B5	132M/B5
k	570	590	610	635	684	704	768	806
k1	690	710	735	760	819	839	913	951
n	138	156	176	176	194	218	258	258
n1	110	118	126	126	135	146	168	168
x	-	-	-	-	-	-	1.3	1.3



# Ölçü Sayfaları Dimension Pages Abmessungsseiten



-Mil ucu çekirme deliği DIN 332 sayfa 2 / Tapped center hole to DIN 332, sheet 2 / Zentrierung mit gewinde DIN 332, Blatt 2

KV373.08

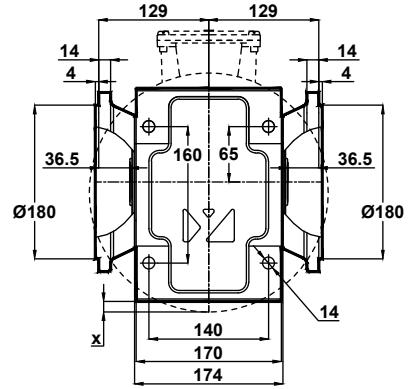
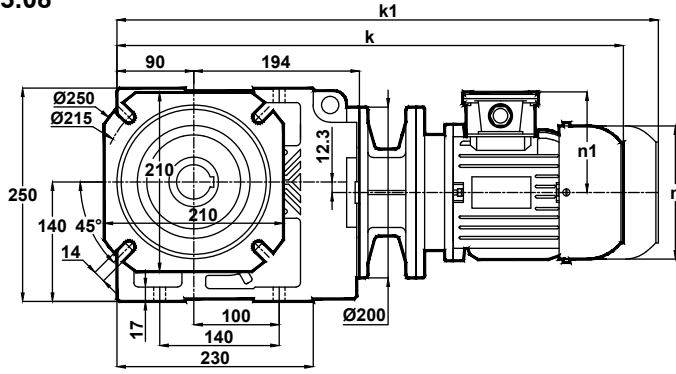

Std.

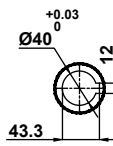

Ops.

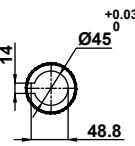

x: Motor ayak bağlantı yüzeyinin altında ise  
x: If Motor is lower than foot mounting plane  
x: Wenn motor ist niedriger den die Anschlußplatte

Klemens Pozisyonları  
Terminal Box Positions  
Klemmenkasten Positionen

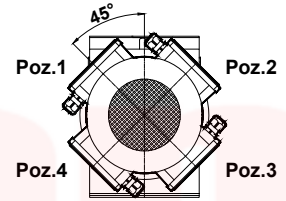

71-80-90-100-112-132  
Tip / Type / Typ

	71/B5	80/B5	90S/B5	90L/B5	100L/B5	112M/B5	132S/B5	132M/B5
k	570	590	610	635	684	704	768	806
k1	690	710	735	760	819	839	913	951
n	138	156	176	176	194	218	258	258
n1	110	118	126	126	135	146	168	168
x	-	-	-	-	-	-	1.3	1.3



# Ölçü Sayfaları Dimension Pages Abmessungenseiten



-Mil ucu çekirme deliği DIN 332 sayfa 2 / Tapped center hole to DIN 332, sheet 2 / Zentrierung mit gewinde DIN 332, Blatt 2

## KV374.00

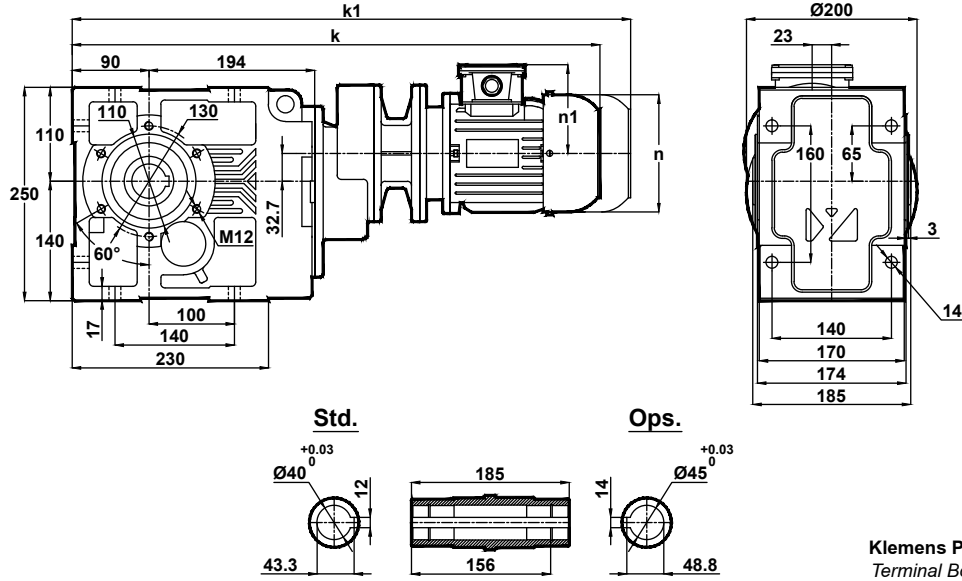

	63/B5	71/B5	80/B5	90S/B5	90L/B5	100L/B5	112M/B5
k	621	618	667	687	712	737	757
k1	-	738	787	812	837	872	892
n	116	138	156	176	176	194	218
n1	97	110	118	126	126	135	146

Klemens Pozisyonları  
Terminal Box Positions  
Klemmenkasten Positionen

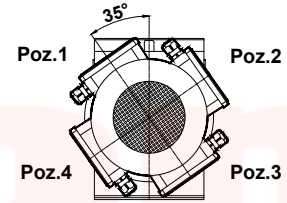

63-71-80-90-100-112  
Tip / Type / Typ

## KV374.01

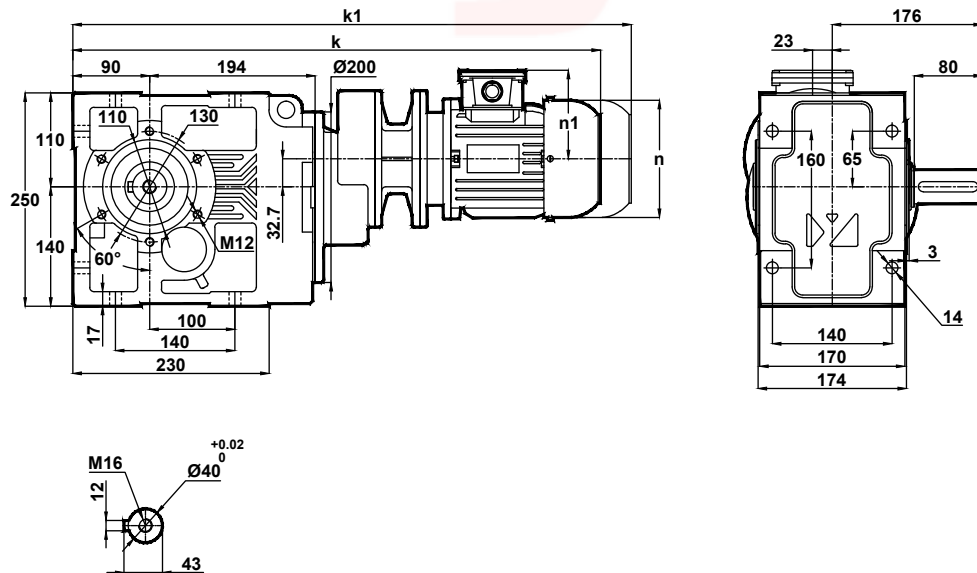

	63/B5	71/B5	80/B5	90S/B5	90L/B5	100L/B5	112M/B5
k	621	618	667	687	712	737	757
k1	-	738	787	812	837	872	892
n	116	138	156	176	176	194	218
n1	97	110	118	126	126	135	146



# Ölçü Sayfaları Dimension Pages Abmessungsseiten



-Mil ucu çekirme deliği DIN 332 sayfa 2 / Tapped center hole to DIN 332, sheet 2 / Zentrierung mit gewinde DIN 332, Blatt 2

## KV374.02

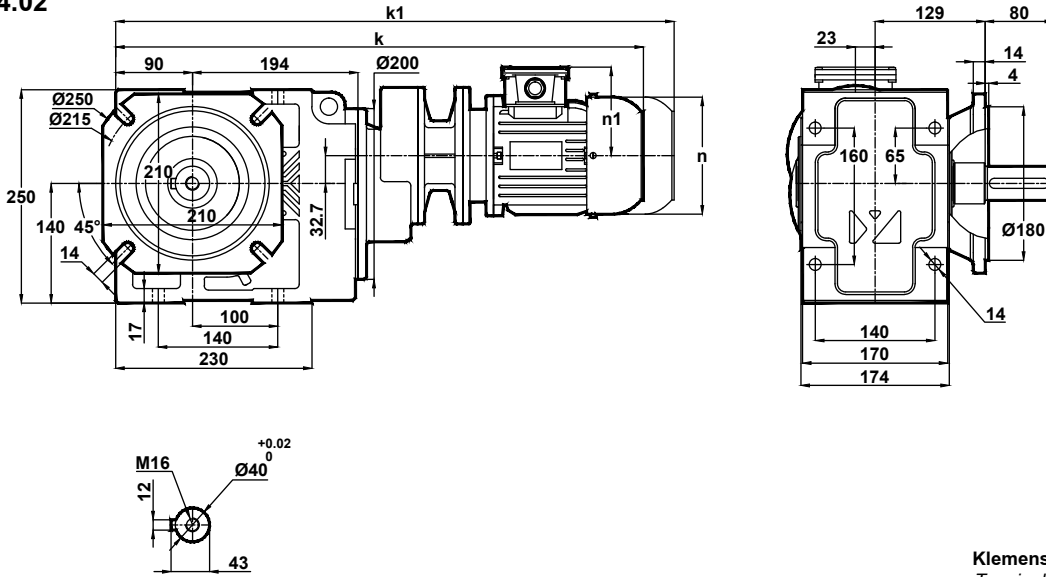

	63/B5	71/B5	80/B5	90S/B5	90L/B5	100L/B5	112M/B5
k	621	618	667	687	712	737	757
k1	-	738	787	812	837	872	892
n	116	138	156	176	176	194	218
n1	97	110	118	126	126	135	146

Klemens Pozisyonları  
Terminal Box Positions  
Klemmenkasten Positionen

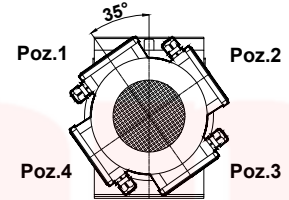

63-71-80-90-100-112  
Tip / Type / Typ

## KV374.03

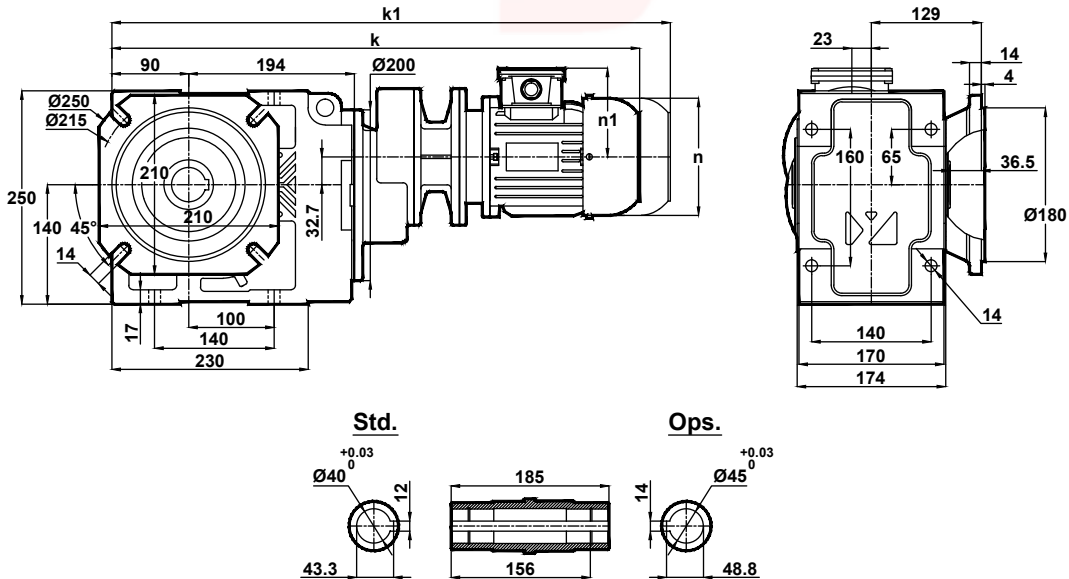

Std.

Ops.

	63/B5	71/B5	80/B5	90S/B5	90L/B5	100L/B5	112M/B5
k	621	618	667	687	712	737	757
k1	-	738	787	812	837	872	892
n	116	138	156	176	176	194	218
n1	97	110	118	126	126	135	146



# Ölçü Sayfaları

## Dimension Pages

### Abmessungsseiten



-Mil ucu çektirme deliği DIN 332 sayfa 2 / Tapped center hole to DIN 332, sheet 2 / Zentrierung mit gewinde DIN 332, Blatt 2

#### KV374.04

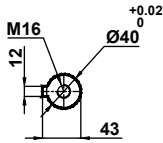
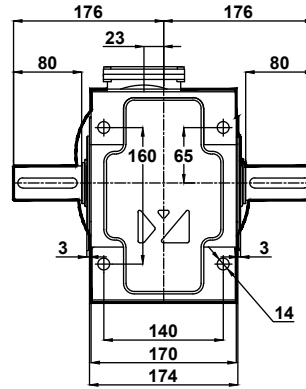
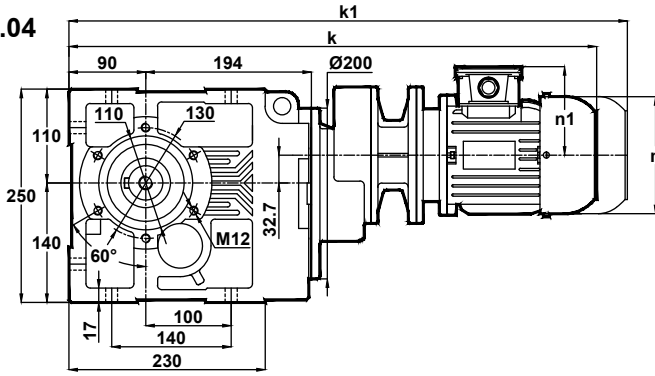

	63/B5	71/B5	80/B5	90S/B5	90L/B5	100L/B5	112M/B5
k	621	618	667	687	712	737	757
k1	-	738	787	812	837	872	892
n	116	138	156	176	176	194	218
n1	97	110	118	126	126	135	146

#### Klemens Pozisyonları

Terminal Box Positions  
Klemmenkasten Positionen

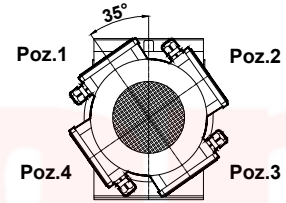

63-71-80-90-100-112  
Tip / Type / Typ

#### KV374.05

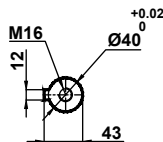
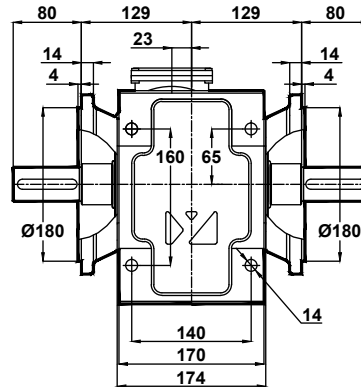
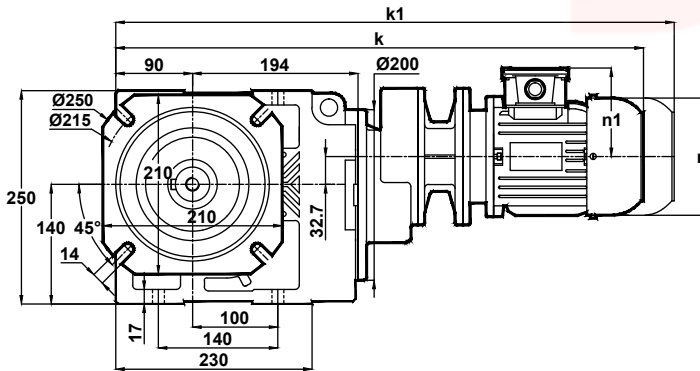

	63/B5	71/B5	80/B5	90S/B5	90L/B5	100L/B5	112M/B5
k	621	618	667	687	712	737	757
k1	-	738	787	812	837	872	892
n	116	138	156	176	176	194	218
n1	97	110	118	126	126	135	146



# Ölçü Sayfaları Dimension Pages Abmessungsseiten



-Mil ucu çekirme deliği DIN 332 sayfa 2 / Tapped center hole to DIN 332, sheet 2 / Zentrierung mit gewinde DIN 332, Blatt 2

KV374.08

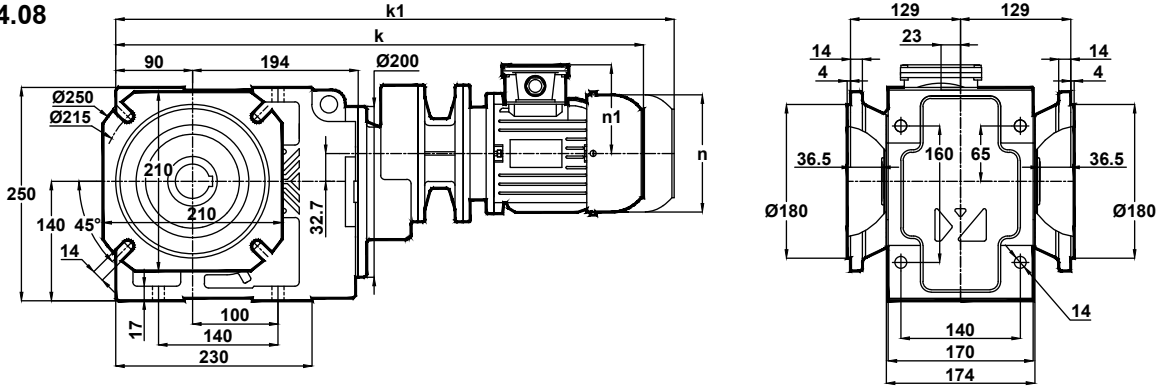

Std.

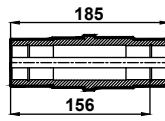
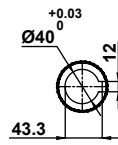

Ops.

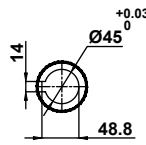

Klemens Pozisyonları  
Terminal Box Positions  
Klemmenkasten Positionen

	63/B5	71/B5	80/B5	90S/B5	90L/B5	100L/B5	112M/B5
k	547	566	594	622	647	691	711
k1	-	686	714	747	772	826	846
n	116	138	156	176	176	194	218
n1	97	110	118	126	126	135	146

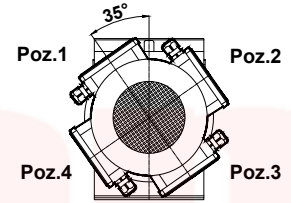

63-71-80-90-100-112  
Tip / Type / Typ



# Ölçü Sayfaları Dimension Pages Abmessungsseiten



-Mil ucu çektirme deliği DIN 332 sayfa 2 / Tapped center hole to DIN 332, sheet 2 / Zentrierung mit gewinde DIN 332, Blatt 2

KV375.00  
KV376.00

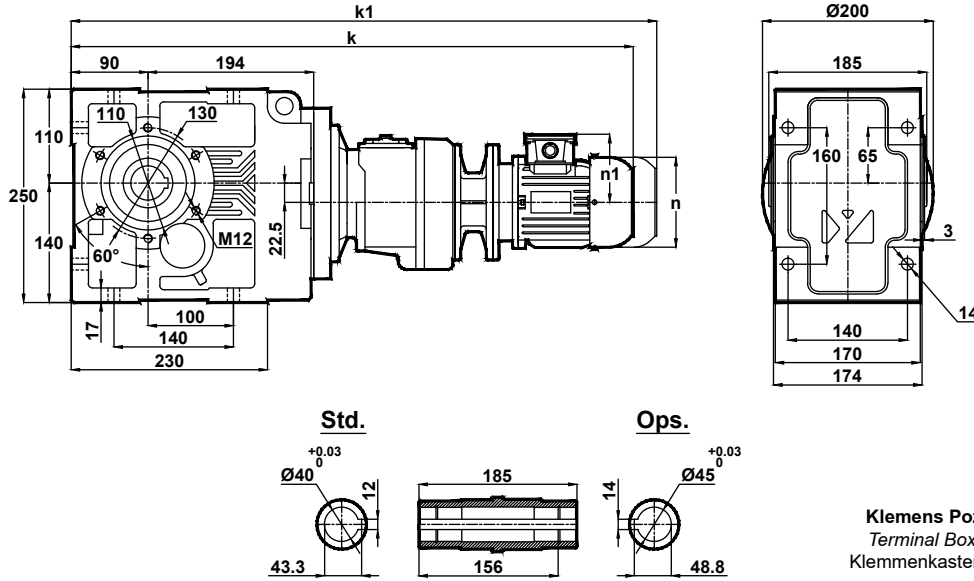

	63/B5	71/B5	80/B5	90S/B5	90L/B5
k	688	714	749	769	794
k1	-	834	869	894	919
n	116	138	156	176	176
n1	97	110	118	126	126

Klemens Pozisyonları  
Terminal Box Positions  
Klemmenkasten Positionen

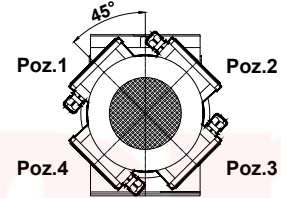

63-71-80-90  
Tip / Type / Typ

KV375.01  
KV376.01

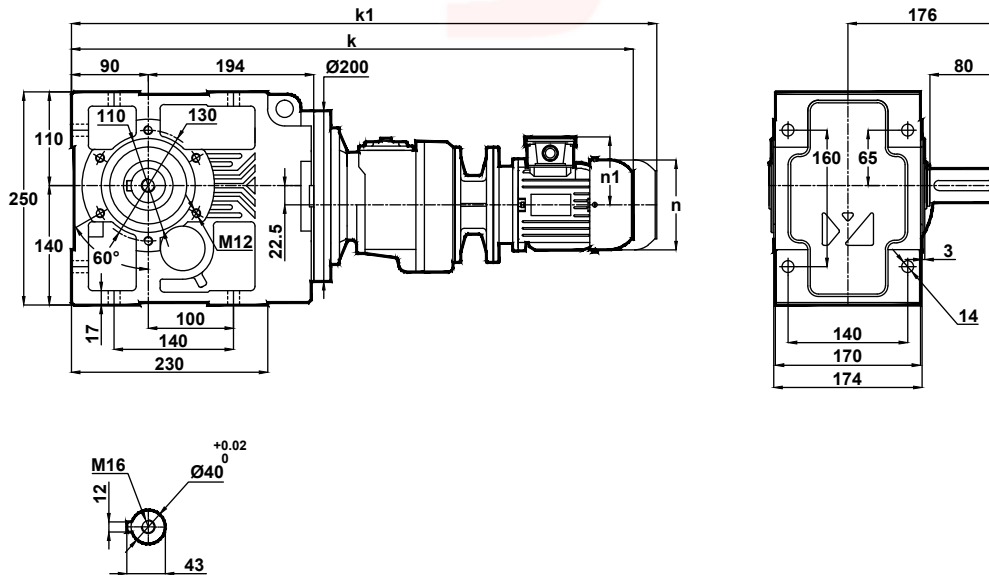

	63/B5	71/B5	80/B5	90S/B5	90L/B5
k	688	714	749	769	794
k1	-	834	869	894	919
n	116	138	156	176	176
n1	97	110	118	126	126





# Ölçü Sayfaları Dimension Pages Abmessungenseiten



-Mil ucu çekirme deliği DIN 332 sayfa 2 / Tapped center hole to DIN 332, sheet 2 / Zentrierung mit gewinde DIN 332, Blatt 2

KV375.02  
KV376.02

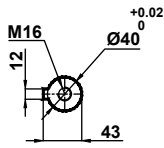
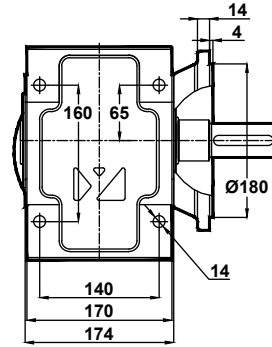
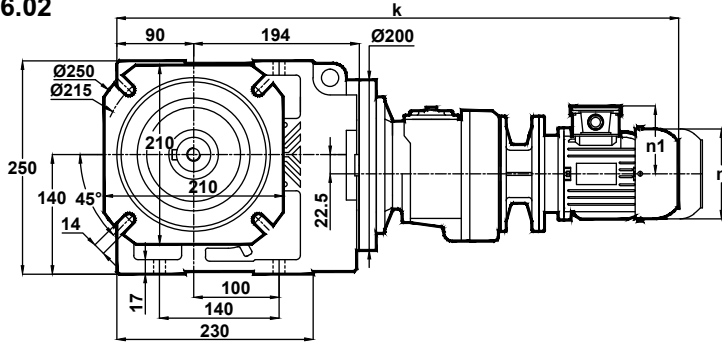

	63/B5	71/B5	80/B5	90S/B5	90L/B5
k	688	714	749	769	794
k1	-	834	869	894	919
n	116	138	156	176	176
n1	97	110	118	126	126

Klemens Pozisyonları  
Terminal Box Positions  
Klemmenkasten Positionen

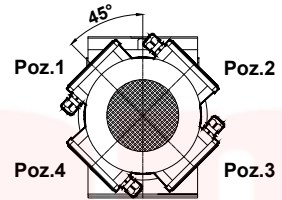

63-71-80-90  
Tip / Type / Typ

KV375.03  
KV376.03

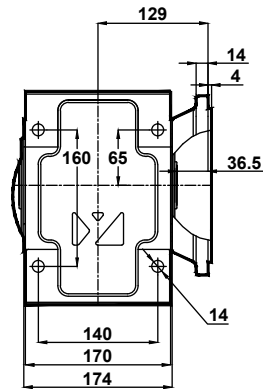
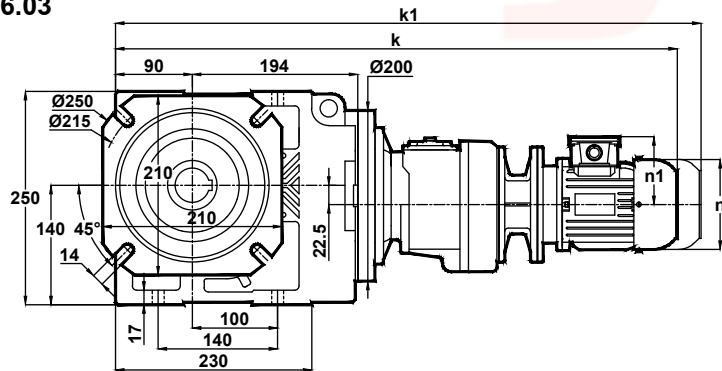

Std.

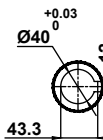

Ops.

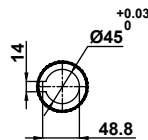

	63/B5	71/B5	80/B5	90S/B5	90L/B5
k	688	714	749	769	794
k1	-	834	869	894	919
n	116	138	156	176	176
n1	97	110	118	126	126



# Ölçü Sayfaları Dimension Pages Abmessungsseiten



-Mil ucu çekirme deliği DIN 332 sayfa 2 / Tapped center hole to DIN 332, sheet 2 / Zentrierung mit gewinde DIN 332, Blatt 2

KV375.04  
KV376.04

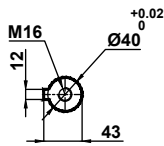
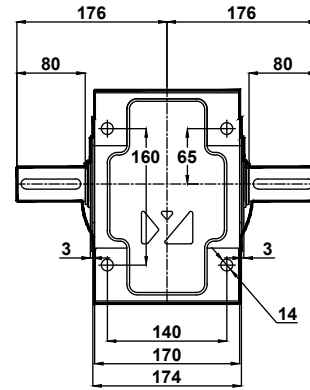
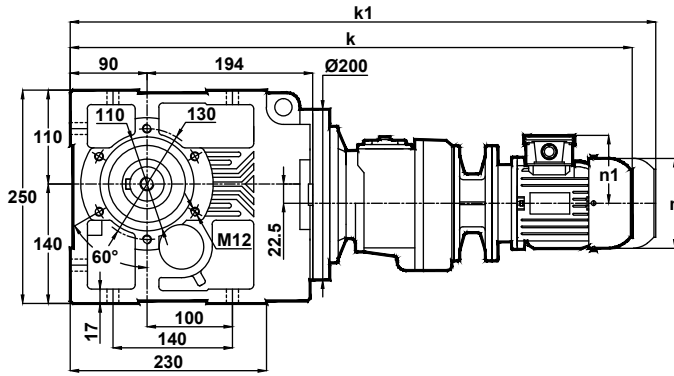

	63/B5	71/B5	80/B5	90S/B5	90L/B5
k	688	714	749	769	794
k1	-	834	869	894	919
n	116	138	156	176	176
n1	97	110	118	126	126

Klemens Pozisyonları  
Terminal Box Positions  
Klemmenkasten Positionen

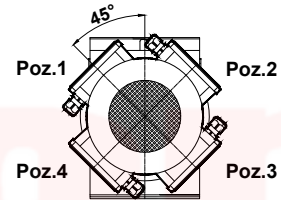

63-71-80-90  
ip / Type / Typ

KV375.05  
KV376.05

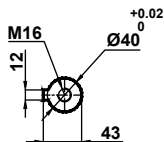
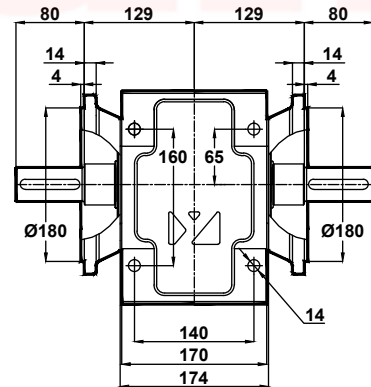
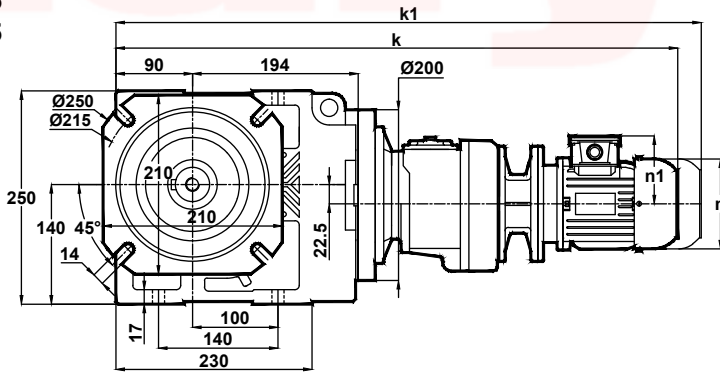

	63/B5	71/B5	80/B5	90S/B5	90L/B5
k	688	714	749	769	794
k1	-	834	869	894	919
n	116	138	156	176	176
n1	97	110	118	126	126



# Ölçü Sayfaları Dimension Pages Abmessungsseiten



-Mil ucu çekirme deliği DIN 332 sayfa 2 / Tapped center hole to DIN 332, sheet 2 / Zentrierung mit gewinde DIN 332, Blatt 2

KV375.08  
KV376.08

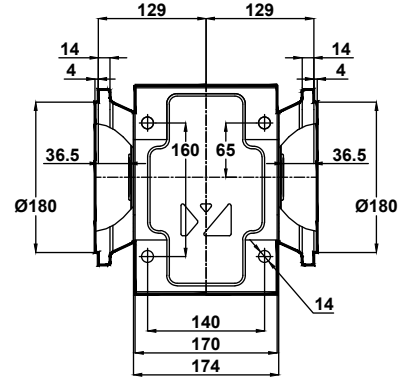
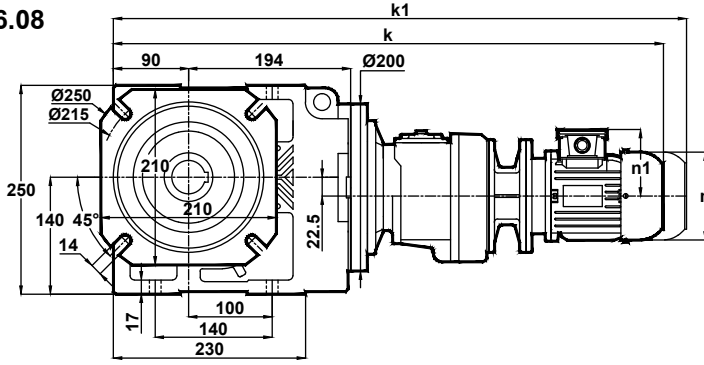

Std.

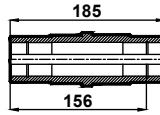
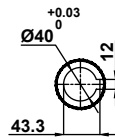

Ops.

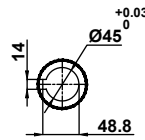

	63/B5	71/B5	80/B5	90S/B5	90L/B5
k	688	714	749	769	794
k1	-	834	869	894	919
n	116	138	156	176	176
n1	97	110	118	126	126

Klemens Pozisyonları  
Terminal Box Positions  
Klemmenkasten Positionen

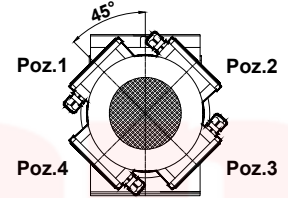

63-71-80-90  
Tip / Type / Typ



# Ölçü Sayfaları Dimension Pages Abmessungsseiten



-Mil ucu çekirme deliği DIN 332 sayfa 2 / Tapped center hole to DIN 332, sheet 2 / Zentrierung mit gewinde DIN 332, Blatt 2

## KV473.00

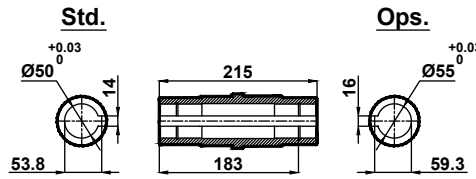
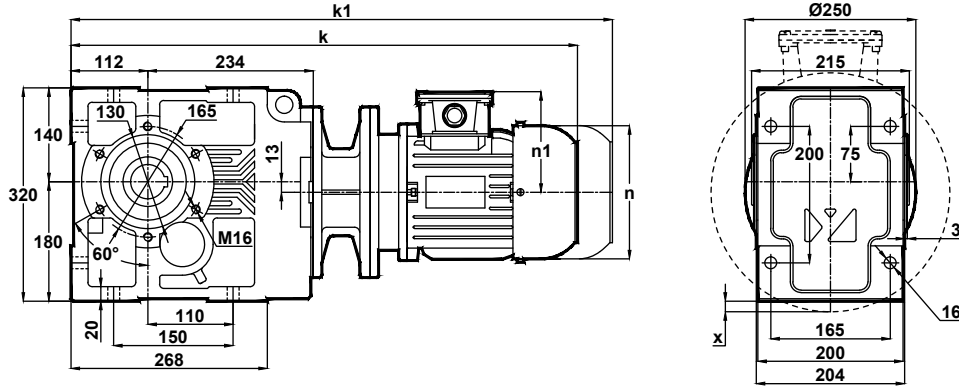

x: Motor Ayak bağlantı yüzeyinin altında ise  
x: If Motor is lower then foot mounting plane  
x:Wen motor ist nidriger den die Anschlußplatte

Klemens Pozisyonları  
Terminal Box Positions  
Klemmenkasten Positionen

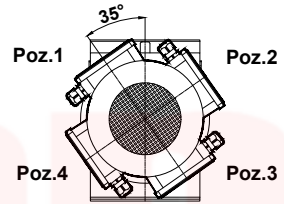

80-90-100-112-132-160-180  
Tip / Type / Typ

	80/B5	90S/B5	90L/B5	100L/B5	112M/B5	132S/B5	132M/B5	160M/B5	160L/B5	180M/B5	180L/B5
k	642	662	687	737	757	820	858	1009	1053	1066	1104
k1	762	787	812	872	892	965	1003	1179	1223	1236	1274
n	156	176	176	194	218	258	258	310	310	348	348
n1	118	126	126	135	146	168	168	225	225	241	241
x	-	-	-	-	-	-	-	-	-	7	7

## KV473.01

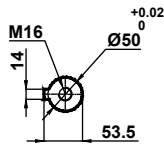
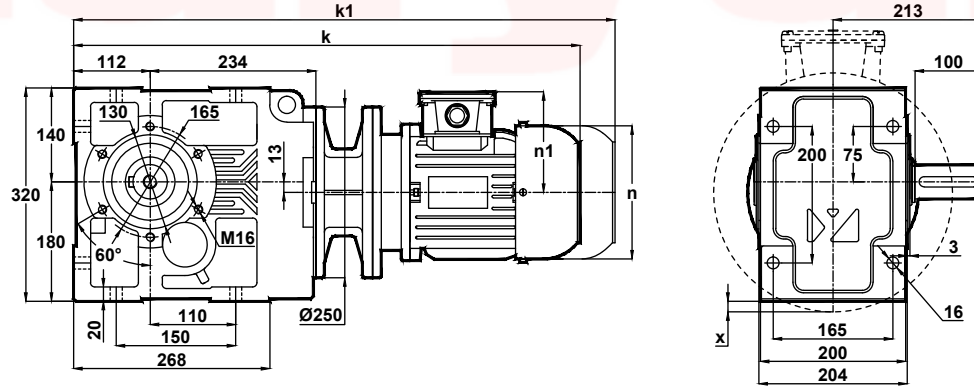

x: Motor Ayak bağlantı yüzeyinin altında ise  
x: If Motor is lower then foot mounting plane  
x:Wen motor ist nidriger den die Anschlußplatte

	80/B5	90S/B5	90L/B5	100L/B5	112M/B5	132S/B5	132M/B5	160M/B5	160L/B5	180M/B5	180L/B5
k	642	662	687	737	757	820	858	1009	1053	1066	1104
k1	762	787	812	872	892	965	1003	1179	1223	1236	1274
n	156	176	176	194	218	258	258	310	310	348	348
n1	118	126	126	135	146	168	168	225	225	241	241
x	-	-	-	-	-	-	-	-	-	7	7



# Ölçü Sayfaları

## Dimension Pages

### Abmessungsseiten



-Mil ucu çektirme deliği DIN 332 sayfa 2 / Tapped center hole to DIN 332, sheet 2 / Zentrierung mit gewinde DIN 332, Blatt 2

#### KV473.02

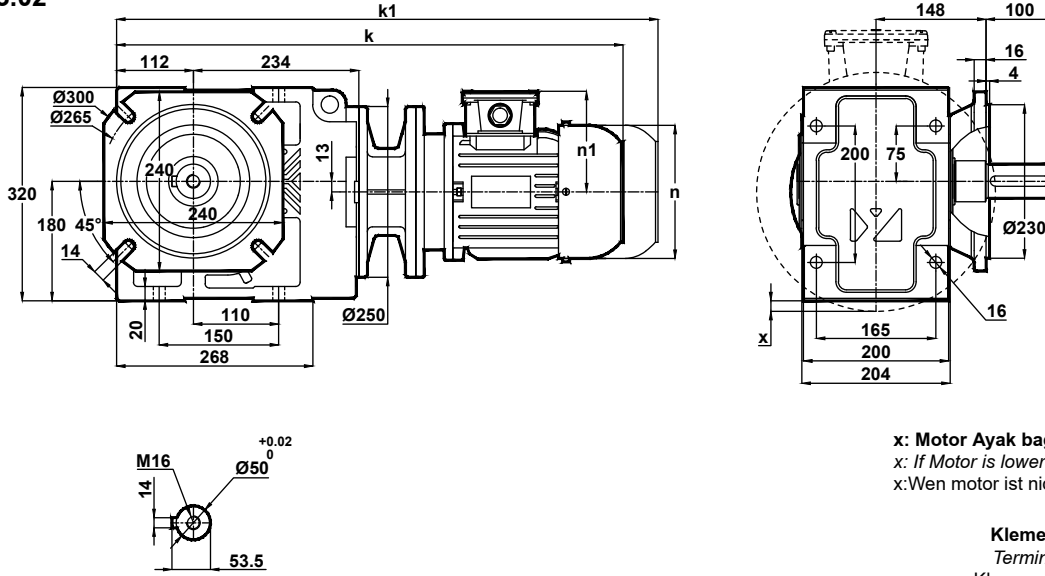

x: Motor Ayak bağlantı yüzeyinin altında ise  
x: If Motor is lower then foot mounting plane  
x:Wen motor ist nidriger den die Anschlußplatte

Klemens Pozisyonları  
Terminal Box Positions  
Klemmenkasten Positionen

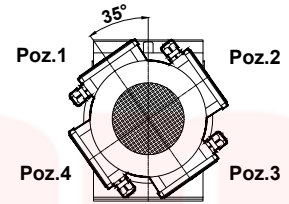

80-90-100-112-132-160-180  
Tip / Type / Typ

	80/B5	90S/B5	90L/B5	100L/B5	112M/B5	132S/B5	132M/B5	160M/B5	160L/B5	180M/B5	180L/B5
k	642	662	687	737	757	820	858	1009	1053	1066	1104
k1	762	787	812	872	892	965	1003	1179	1223	1236	1274
n	156	176	176	194	218	258	258	310	310	348	348
n1	118	126	126	135	146	168	168	225	225	241	241
x	-	-	-	-	-	-	-	-	-	7	7

#### KV473.03

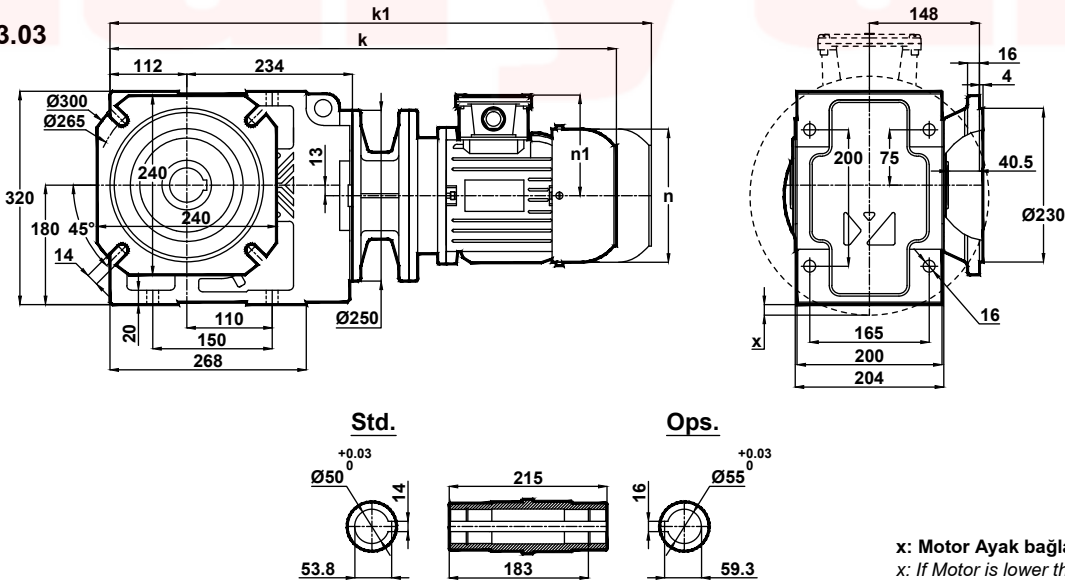

x: Motor Ayak bağlantı yüzeyinin altında ise  
x: If Motor is lower then foot mounting plane  
x:Wen motor ist nidriger den die Anschlußplatte

	80/B5	90S/B5	90L/B5	100L/B5	112M/B5	132S/B5	132M/B5	160M/B5	160L/B5	180M/B5	180L/B5
k	642	662	687	737	757	820	858	1009	1053	1066	1104
k1	762	787	812	872	892	965	1003	1179	1223	1236	1274
n	156	176	176	194	218	258	258	310	310	348	348
n1	118	126	126	135	146	168	168	225	225	241	241
x	-	-	-	-	-	-	-	-	-	7	7



# Ölçü Sayfaları Dimension Pages Abmessungsseiten



-Mil ucu çektirme deliği DIN 332 sayfa 2 / Tapped center hole to DIN 332, sheet 2 / Zentrierung mit gewinde DIN 332, Blatt 2

## KV473.04

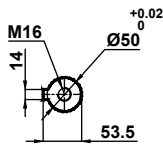
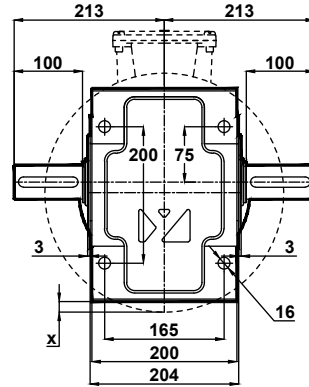
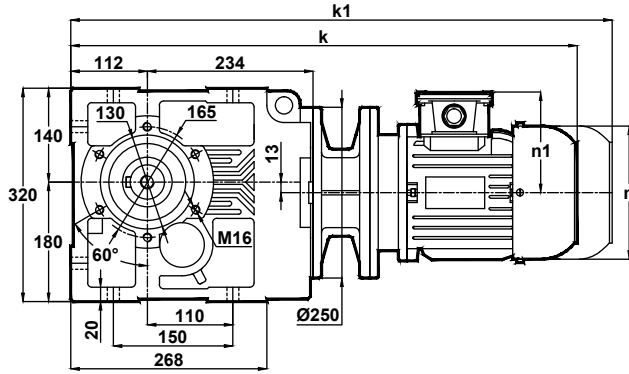

x: Motor Ayak bağlantı yüzeyinin altında ise  
x: If Motor is lower then foot mounting plane  
x:Wen motor ist nidriger den die Anschlußplatte

**Klemens Pozisyonları**  
Terminal Box Positions  
Klemmenkasten Positionen

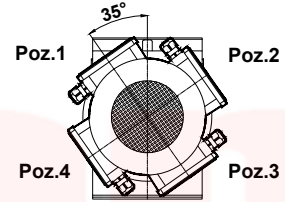

80-90-100-112-132-160-180  
Tip / Type / Typ

	80/B5	90S/B5	90L/B5	100L/B5	112M/B5	132S/B5	132M/B5	160M/B5	160L/B5	180M/B5	180L/B5
k	642	662	687	737	757	820	858	1009	1053	1066	1104
k1	762	787	812	872	892	965	1003	1179	1223	1236	1274
n	156	176	176	194	218	258	258	310	310	348	348
n1	118	126	126	135	146	168	168	225	225	241	241
x	-	-	-	-	-	-	-	-	-	7	7

## KV473.05

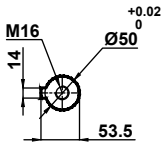
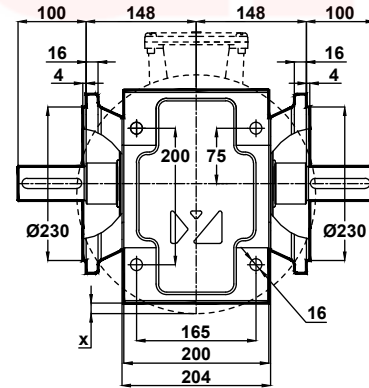
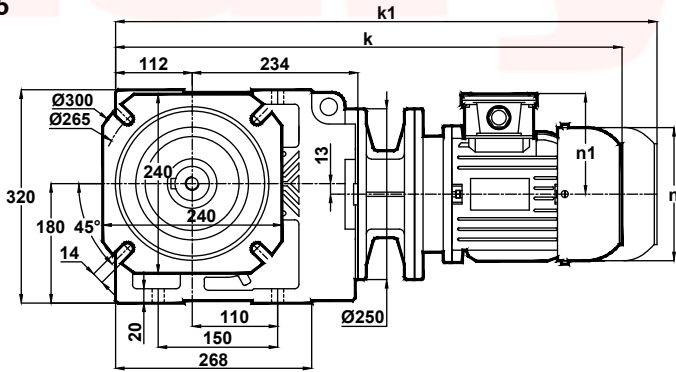

x: Motor Ayak bağlantı yüzeyinin altında ise  
x: If Motor is lower then foot mounting plane  
x:Wen motor ist nidriger den die Anschlußplatte

	80/B5	90S/B5	90L/B5	100L/B5	112M/B5	132S/B5	132M/B5	160M/B5	160L/B5	180M/B5	180L/B5
k	642	662	687	737	757	820	858	1009	1053	1066	1104
k1	762	787	812	872	892	965	1003	1179	1223	1236	1274
n	156	176	176	194	218	258	258	310	310	348	348
n1	118	126	126	135	146	168	168	225	225	241	241
x	-	-	-	-	-	-	-	-	-	7	7



# Ölçü Sayfaları Dimension Pages Abmessungenseiten



-Mil ucu çektirme deliği DIN 332 sayfa 2 / Tapped center hole to DIN 332, sheet 2 / Zentrierung mit gewinde DIN 332, Blatt 2

KV473.08

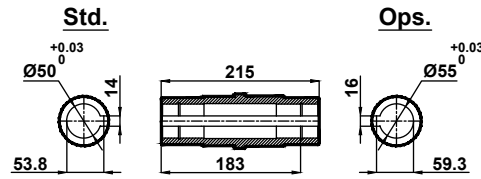
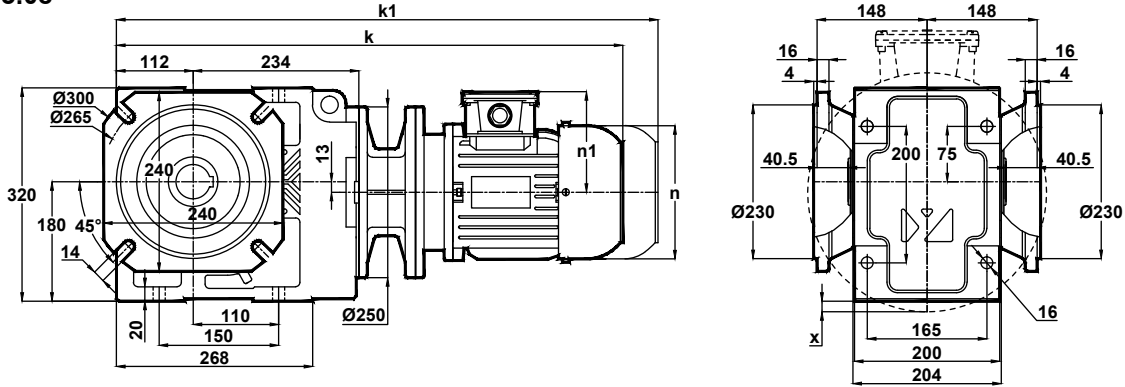

x: Motor Ayak bağlantı yüzeyinin altında ise  
x: If Motor is lower then foot mounting plane  
x: Wenn motor ist niedriger den die Anschlußplatte

Klemens Pozisyonları  
Terminal Box Positions  
Klemmenkasten Positionen

	80/B5	90S/B5	90L/B5	100L/B5	112M/B5	132S/B5	132M/B5	160M/B5	160L/B5	180M/B5	180L/B5
k	642	662	687	737	757	820	858	1009	1053	1066	1104
k1	762	787	812	872	892	965	1003	1179	1223	1236	1274
n	156	176	176	194	218	258	258	310	310	348	348
n1	118	126	126	135	146	168	168	225	225	241	241
x	-	-	-	-	-	-	-	-	-	7	7

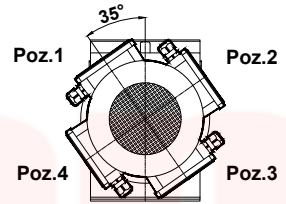

80-90-100-112-132-160-180  
Tip / Type / Typ



# Ölçü Sayfaları

## Dimension Pages

### Abmessungsseiten



-Mil ucu çekirme deliği DIN 332 sayfa 2 / Tapped center hole to DIN 332, sheet 2 / Zentrierung mit gewinde DIN 332, Blatt 2

#### KV474.00

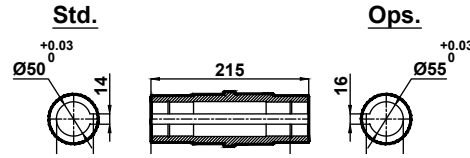
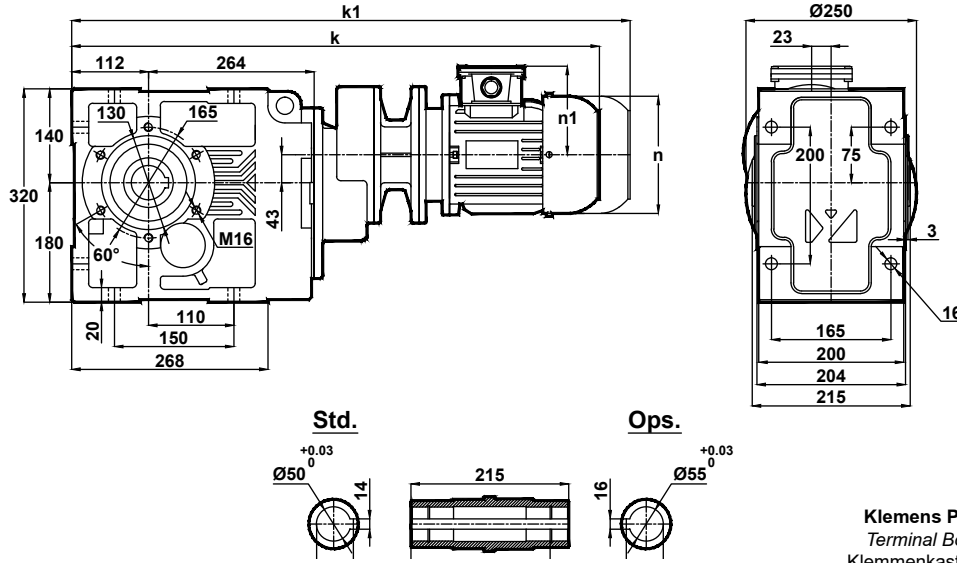

**Klemens Pozisyonları**  
Terminal Box Positions  
Klemmenkasten Positionen

	71/B5	80/B5	90S/B5	90L/B5	100L/B5	112M/B5	132S/B5	132M/B5
k	720	740	760	785	834	854	918	956
k1	840	860	885	910	969	989	1063	1101
n	138	156	176	176	194	218	258	258
n1	110	118	126	126	135	146	168	168

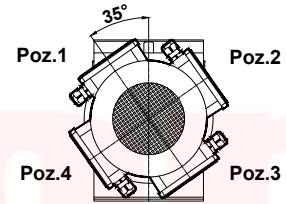

71-80-90-100-112-132  
Tip / Type / Typ

#### KV474.01

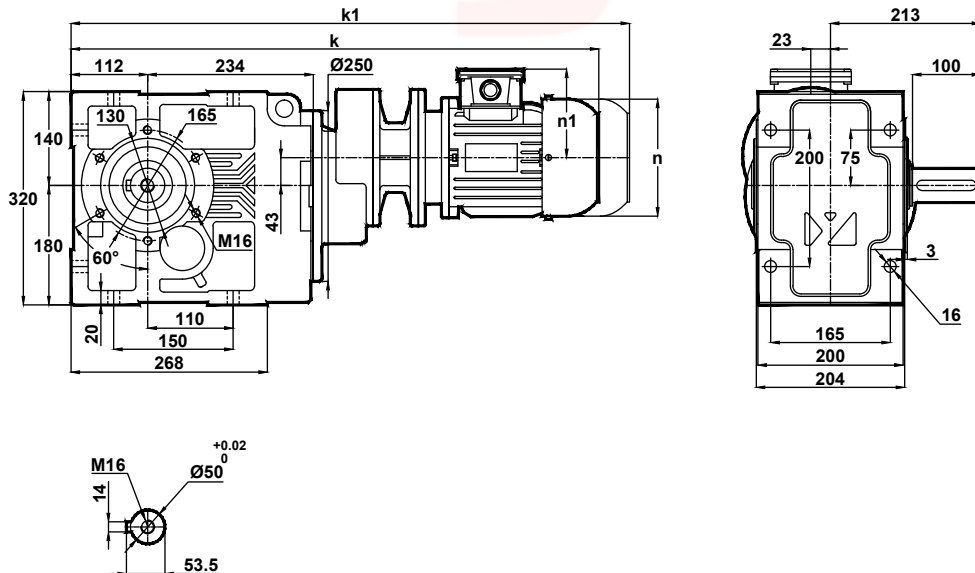

	71/B5	80/B5	90S/B5	90L/B5	100L/B5	112M/B5	132S/B5	132M/B5
k	720	740	760	785	834	854	918	956
k1	840	860	885	910	969	989	1063	1101
n	138	156	176	176	194	218	258	258
n1	110	118	126	126	135	146	168	168





# Ölçü Sayfaları Dimension Pages Abmessungsseiten



-Mil ucu çektirme deliği DIN 332 sayfa 2 / Tapped center hole to DIN 332, sheet 2 / Zentrierung mit gewinde DIN 332, Blatt 2

## KV474.02

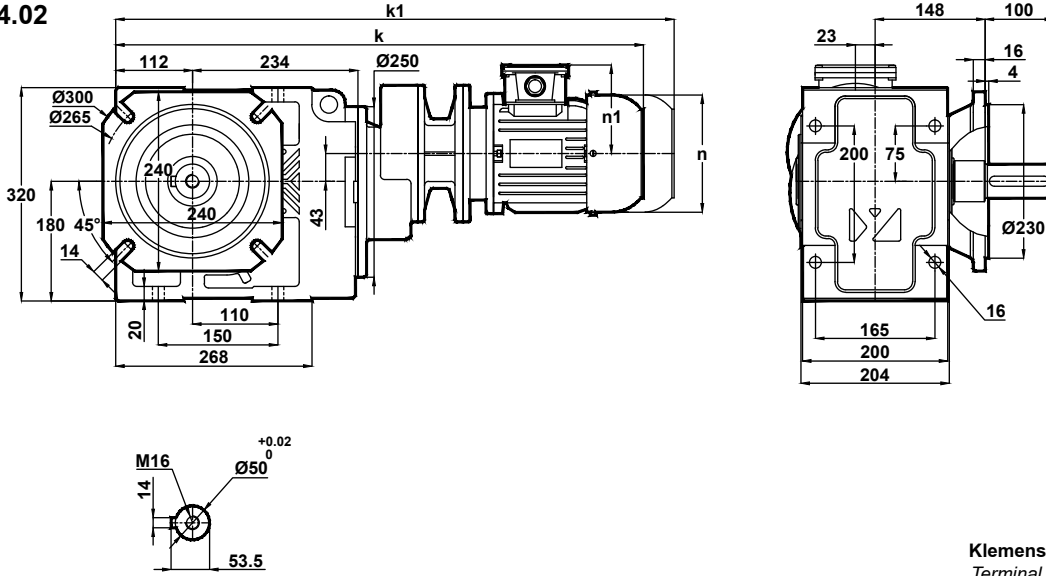

**Klemens Pozisyonları**  
Terminal Box Positions  
Klemmenkasten Positionen

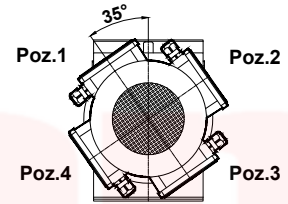

71-80-90-100-112-132  
Tip / Type / Typ

	71/B5	80/B5	90S/B5	90L/B5	100L/B5	112M/B5	132S/B5	132M/B5
k	720	740	760	785	834	854	918	956
k1	840	860	885	910	969	989	1063	1101
n	138	156	176	176	194	218	258	258
n1	110	118	126	126	135	146	168	168

## KV474.03

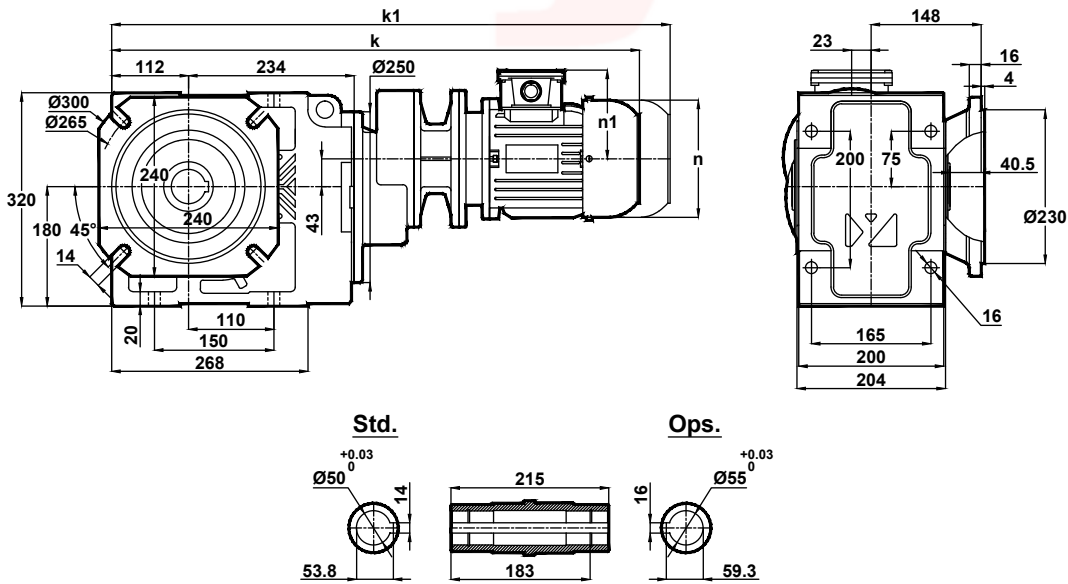

**Std.**

**Ops.**

	71/B5	80/B5	90S/B5	90L/B5	100L/B5	112M/B5	132S/B5	132M/B5
k	720	740	760	785	834	854	918	956
k1	840	860	885	910	969	989	1063	1101
n	138	156	176	176	194	218	258	258
n1	110	118	126	126	135	146	168	168



# Ölçü Sayfaları Dimension Pages Abmessungsseiten



-Mil ucu çekirme deliği DIN 332 sayfa 2 / Tapped center hole to DIN 332, sheet 2 / Zentrierung mit gewinde DIN 332, Blatt 2

## KV474.04

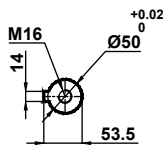
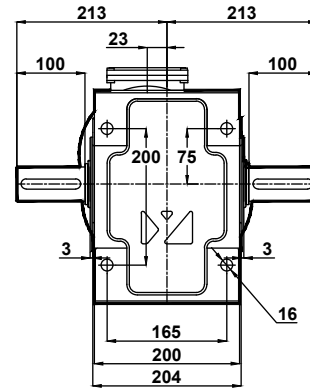
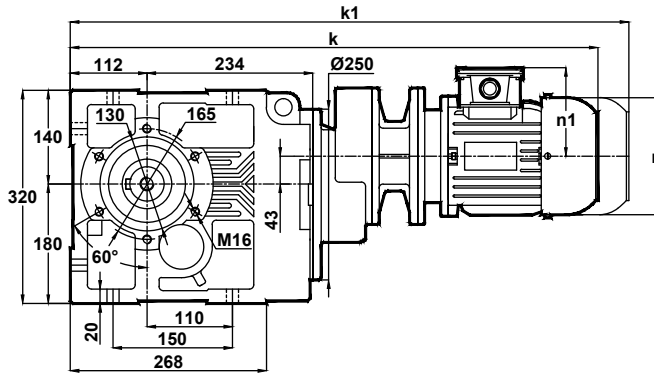

	71/B5	80/B5	90S/B5	90L/B5	100L/B5	112M/B5	132S/B5	132M/B5
k	720	740	760	785	834	854	918	956
k1	840	860	885	910	969	989	1063	1101
n	138	156	176	176	194	218	258	258
n1	110	118	126	126	135	146	168	168

**Klemens Pozisyonları**  
Terminal Box Positions  
Klemmenkasten Positionen

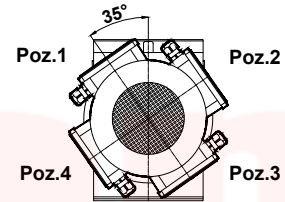

71-80-90-100-112-132  
Tip / Type / Typ

## KV474.05

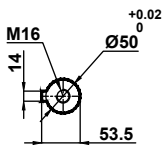
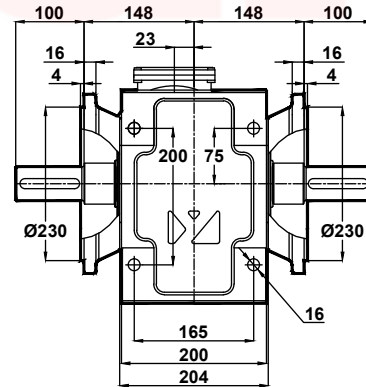
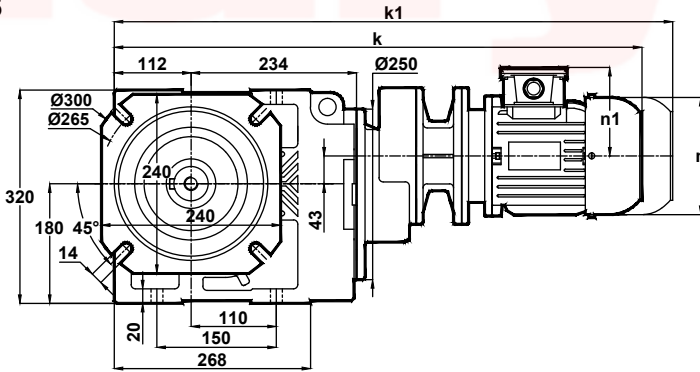

	71/B5	80/B5	90S/B5	90L/B5	100L/B5	112M/B5	132S/B5	132M/B5
k	720	740	760	785	834	854	918	956
k1	840	860	885	910	969	989	1063	1101
n	138	156	176	176	194	218	258	258
n1	110	118	126	126	135	146	168	168



# Ölçü Sayfaları Dimension Pages Abmessungsseiten



-Mil ucu çekirme deliği DIN 332 sayfa 2 / Tapped center hole to DIN 332, sheet 2 / Zentrierung mit gewinde DIN 332, Blatt 2

KV474.08

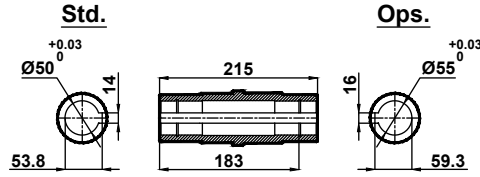
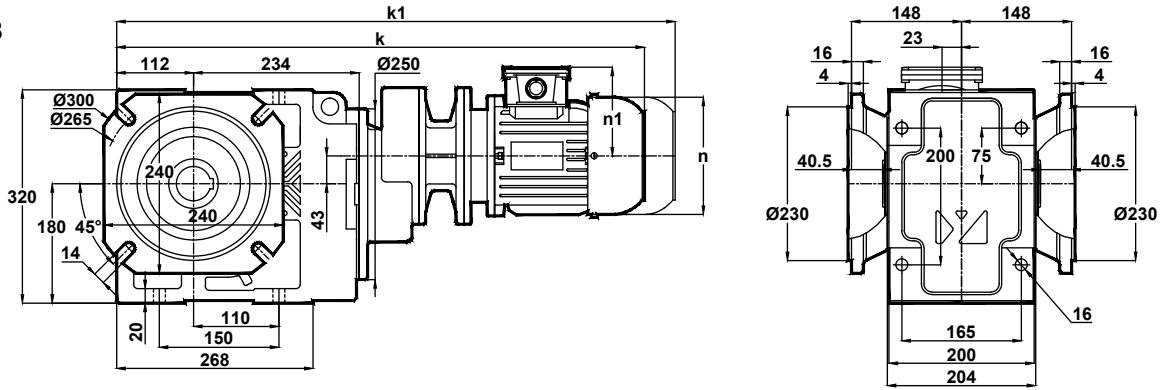

**Klemens Pozisyonları**  
Terminal Box Positions  
Klemmenkasten Positionen

	71/B5	80/B5	90S/B5	90L/B5	100L/B5	112M/B5	132S/B5	132M/B5
k	720	740	760	785	834	854	918	956
k1	840	860	885	910	969	989	1063	1101
n	138	156	176	176	194	218	258	258
n1	110	118	126	126	135	146	168	168

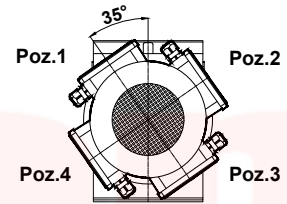

71-80-90-100-112-132  
Tip / Type / Typ



# Ölçü Sayfaları

## Dimension Pages

### Abmessungsseiten



-Mil ucu çektirme deliği DIN 332 sayfa 2 / Tapped center hole to DIN 332, sheet 2 / Zentrierung mit gewinde DIN 332, Blatt 2

KV475.00  
KV476.00

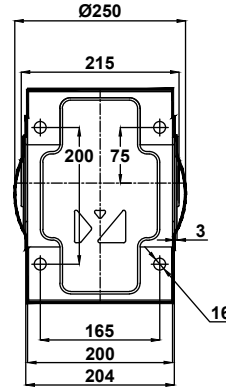
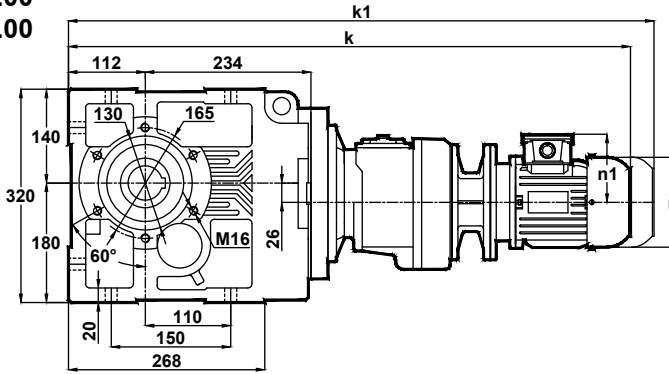

Std.

Ops.

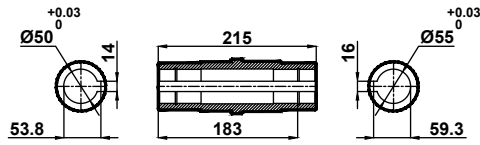

Klemens Pozisyonları  
Terminal Box Positions  
Klemmenkasten Positionen

	63/B5	71/B5	80/B5	90S/B5	90L/B5	100L/B5	112M/B5
k	822	819	868	888	913	938	958
k1	-	939	988	1013	1038	1073	1093
n	116	138	156	176	176	194	218
n1	97	110	118	126	126	135	146

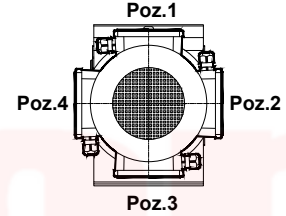

63-71-80-90-100-112  
Tip / Type / Typ

KV475.01  
KV476.01

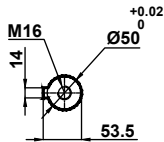
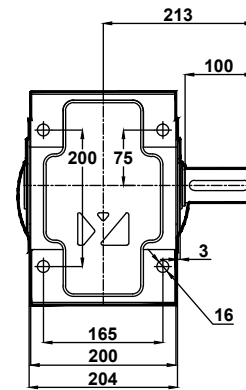
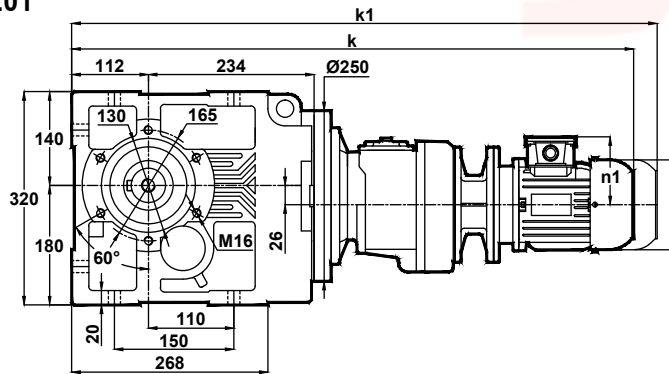

	63/B5	71/B5	80/B5	90S/B5	90L/B5	100L/B5	112M/B5
k	822	819	868	888	913	938	958
k1	-	939	988	1013	1038	1073	1093
n	116	138	156	176	176	194	218
n1	97	110	118	126	126	135	146



# Ölçü Sayfaları Dimension Pages Abmessungsseiten



-Mil ucu çekirme deliği DIN 332 sayfa 2 / Tapped center hole to DIN 332, sheet 2 / Zentrierung mit gewinde DIN 332, Blatt 2

KV475.02  
KV476.02

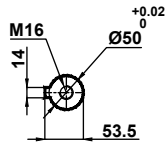
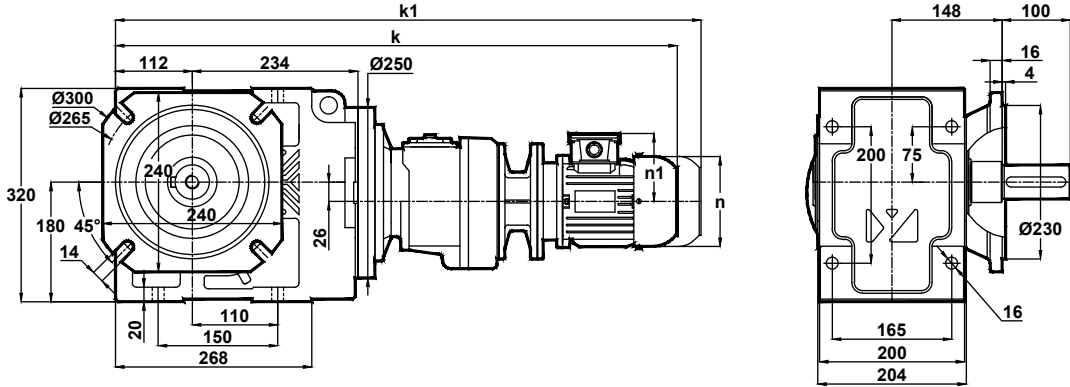

Klemens Pozisyonları  
Terminal Box Positions  
Klemmenkasten Positionen

	63/B5	71/B5	80/B5	90S/B5	90L/B5	100L/B5	112M/B5
k	822	819	868	888	913	938	958
k1	-	939	988	1013	1038	1073	1093
n	116	138	156	176	176	194	218
n1	97	110	118	126	126	135	146

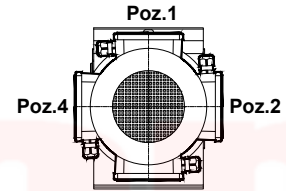

Poz.3  
63-71-80-90-100-112  
Tip / Type / Typ

KV475.03  
KV476.03

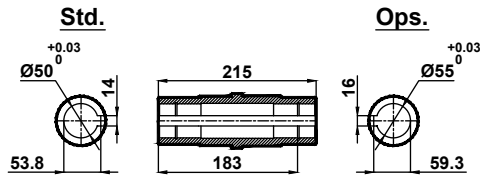
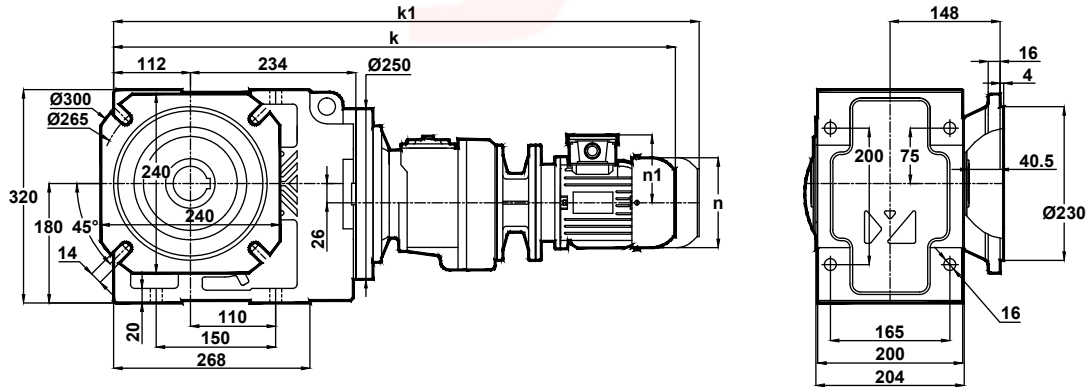

	63/B5	71/B5	80/B5	90S/B5	90L/B5	100L/B5	112M/B5
k	822	819	868	888	913	938	958
k1	-	939	988	1013	1038	1073	1093
n	116	138	156	176	176	194	218
n1	97	110	118	126	126	135	146



# Ölçü Sayfaları Dimension Pages Abmessungenseiten



-Mil ucu çekirme deliği DIN 332 sayfa 2 / Tapped center hole to DIN 332, sheet 2 / Zentrierung mit gewinde DIN 332, Blatt 2

KV475.04  
KV476.04

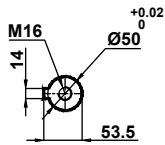
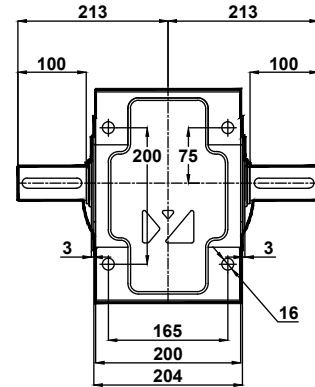
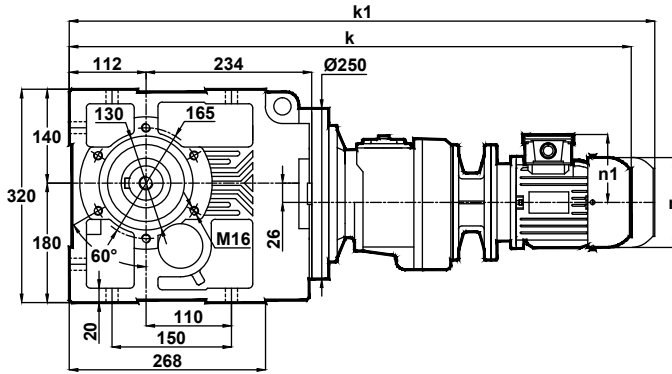

	63/B5	71/B5	80/B5	90S/B5	90L/B5	100L/B5	112M/B5
k	822	819	868	888	913	938	958
k1	-	939	988	1013	1038	1073	1093
n	116	138	156	176	176	194	218
n1	97	110	118	126	126	135	146

Klemens Pozisyonları  
Terminal Box Positions  
Klemmenkasten Positionen

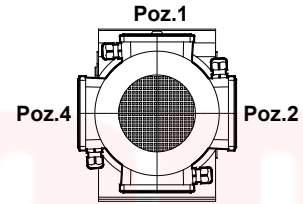

Poz.3  
63-71-80-90-100-112  
Tip / Type / Typ

KV475.05  
KV476.05

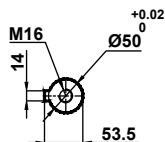
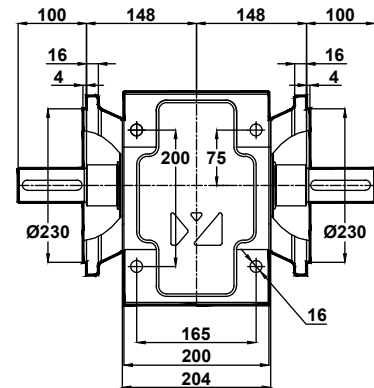
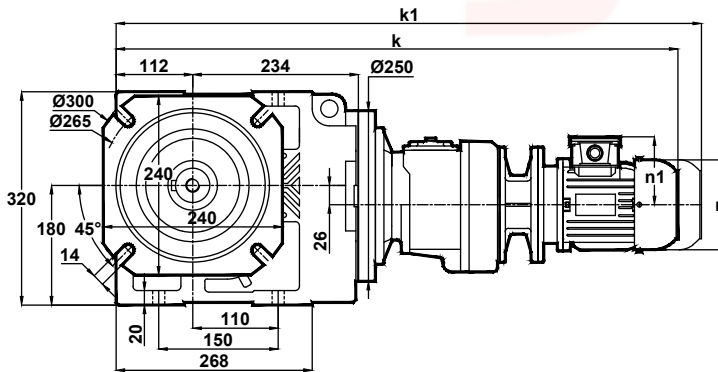

	63/B5	71/B5	80/B5	90S/B5	90L/B5	100L/B5	112M/B5
k	822	819	868	888	913	938	958
k1	-	939	988	1013	1038	1073	1093
n	116	138	156	176	176	194	218
n1	97	110	118	126	126	135	146



# Ölçü Sayfaları Dimension Pages Abmessungsseiten



-Mil ucu çekirme deliği DIN 332 sayfa 2 / Tapped center hole to DIN 332, sheet 2 / Zentrierung mit gewinde DIN 332, Blatt 2

KV475.08  
KV476.08

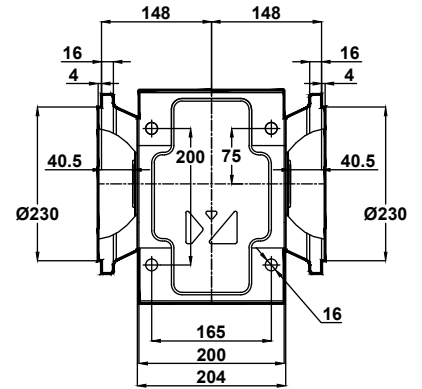
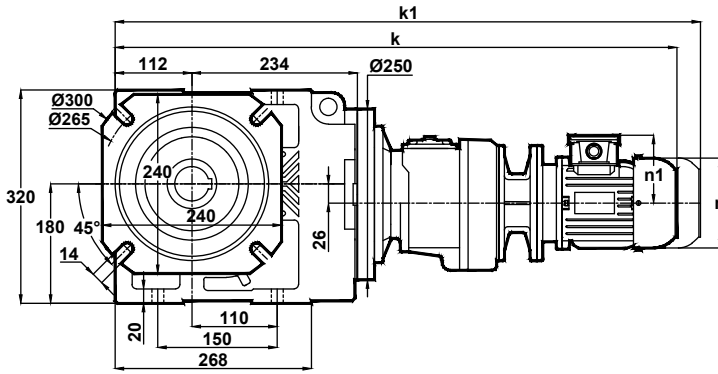

Std.

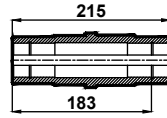
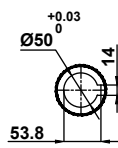

Ops.

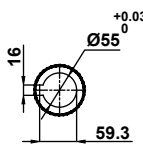

Klemens Pozisyonları  
Terminal Box Positions  
Klemmenkasten Positionen

	63/B5	71/B5	80/B5	90S/B5	90L/B5	100L/B5	112M/B5
k	822	819	868	888	913	938	958
k1	-	939	988	1013	1038	1073	1093
n	116	138	156	176	176	194	218
n1	97	110	118	126	126	135	146

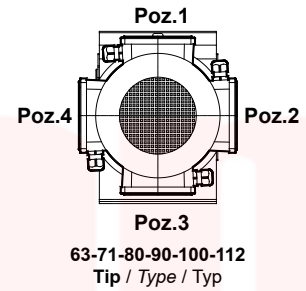



# Ölçü Sayfaları Dimension Pages Abmessungsseiten



-Mil ucu çekirme deliği DIN 332 sayfa 2 / Tapped center hole to DIN 332, sheet 2 / Zentrierung mit gewinde DIN 332, Blatt 2

## KV573.00

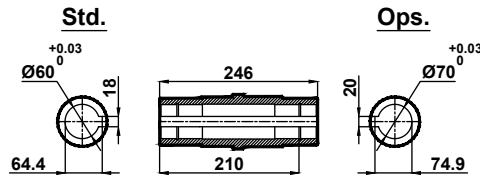
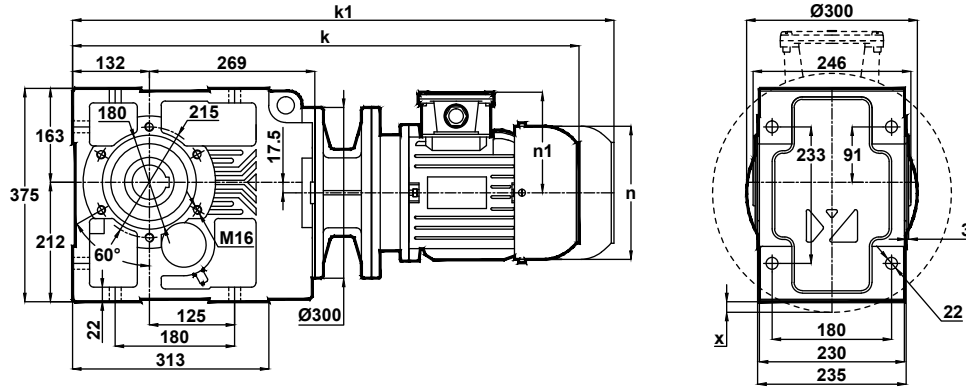

x: Motor Ayak bağlantı yüzeyinin altında ise  
x: If Motor is lower then foot mounting plane  
x: Wenn motor ist niedriger den die Anschlußplatte

	100L/B5	112M/B5	132S/B5	132M/B5	160M/B5	160L/B5	180M/B5	180L/B5	200L/B5
k	790	810	875	913	1060	1104	1117	1155	1227
k1	925	945	1020	1058	1230	1274	1287	1325	1427
n	194	218	258	258	310	310	348	348	390
n1	135	146	168	168	225	225	241	241	275
x	-	-	-	-	-	-	-	-	0.5

Klemens Pozisyonları  
Terminal Box Positions  
Klemmenkasten Positionen

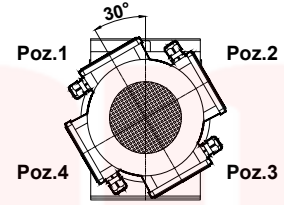

100-112-132-160-180-200  
Tip / Type / Typ

## KV573.01

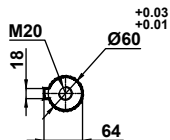
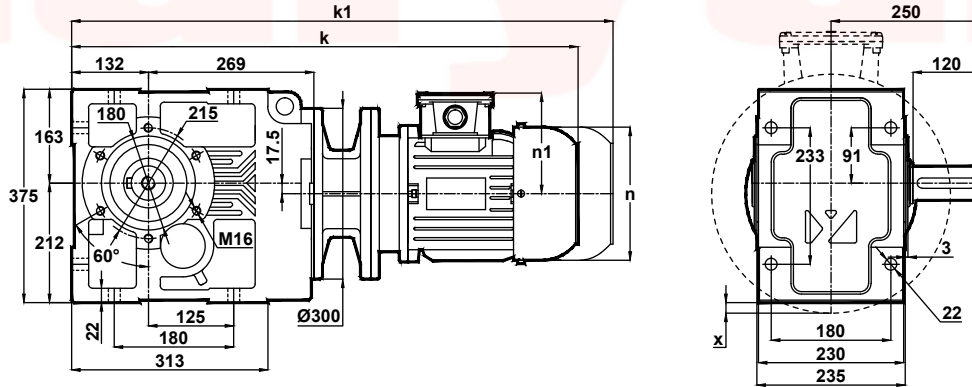

x: Motor Ayak bağlantı yüzeyinin altında ise  
x: If Motor is lower then foot mounting plane  
x: Wenn motor ist niedriger den die Anschlußplatte

	100L/B5	112M/B5	132S/B5	132M/B5	160M/B5	160L/B5	180M/B5	180L/B5	200L/B5
k	790	810	875	913	1060	1104	1117	1155	1227
k1	925	945	1020	1058	1230	1274	1287	1325	1427
n	194	218	258	258	310	310	348	348	390
n1	135	146	168	168	225	225	241	241	275
x	-	-	-	-	-	-	-	-	0.5





# Ölçü Sayfaları Dimension Pages Abmessungsseiten



-Mil ucu çektirme deliği DIN 332 sayfa 2 / Tapped center hole to DIN 332, sheet 2 / Zentrierung mit gewinde DIN 332, Blatt 2

## KV573.02

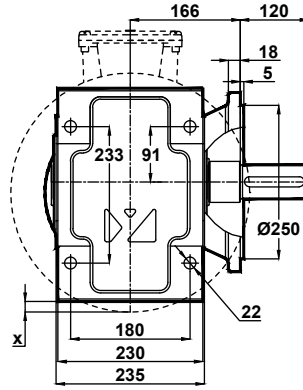
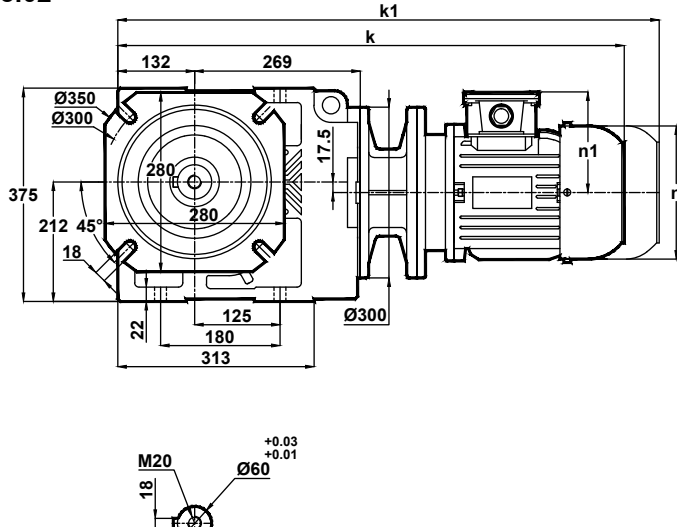

x: Motor Ayak bağlantı yüzeyinin altında ise  
x: If Motor is lower then foot mounting plane  
x: Wenn motor ist niedriger den die Anschlußplatte

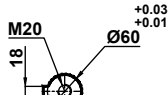

**Klemens Pozisyonları**  
Terminal Box Positions  
Klemmenkasten Positionen

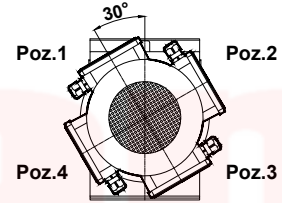

100-112-132-160-180-200  
Tip / Type / Typ

	100L/B5	112M/B5	132S/B5	132M/B5	160M/B5	160L/B5	180M/B5	180L/B5	200L/B5
k	790	810	875	913	1060	1104	1117	1155	1227
k1	925	945	1020	1058	1230	1274	1287	1325	1427
n	194	218	258	258	310	310	348	348	390
n1	135	146	168	168	225	225	241	241	275
x	-	-	-	-	-	-	-	-	0.5

## KV573.03

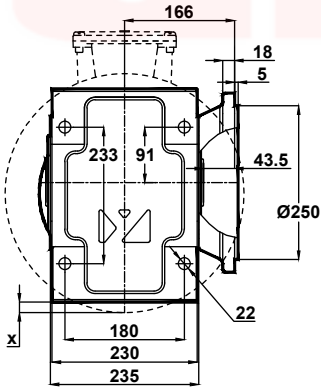
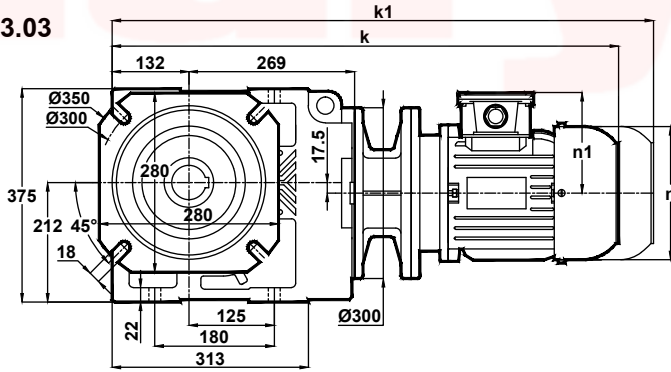

**Std.**

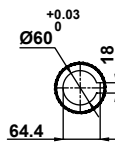

**Ops.**

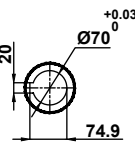

x: Motor Ayak bağlantı yüzeyinin altında ise  
x: If Motor is lower then foot mounting plane  
x: Wenn motor ist niedriger den die Anschlußplatte

	100L/B5	112M/B5	132S/B5	132M/B5	160M/B5	160L/B5	180M/B5	180L/B5	200L/B5
k	790	810	875	913	1060	1104	1117	1155	1227
k1	925	945	1020	1058	1230	1274	1287	1325	1427
n	194	218	258	258	310	310	348	348	390
n1	135	146	168	168	225	225	241	241	275
x	-	-	-	-	-	-	-	-	0.5



# Ölçü Sayfaları

## Dimension Pages

### Abmessungsseiten



-Mil ucu çekirme deliği DIN 332 sayfa 2 / Tapped center hole to DIN 332, sheet 2 / Zentrierung mit gewinde DIN 332, Blatt 2

#### KV573.04

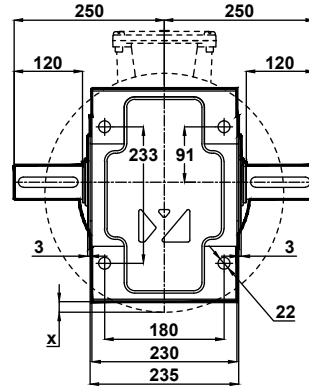
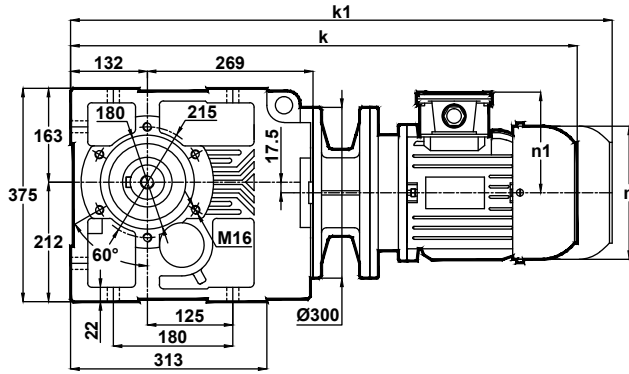

x: Motor Ayak bağlantı yüzeyinin altında ise  
x: If Motor is lower then foot mounting plane  
x: Wenn motor ist niedriger den die Anschlußplatte

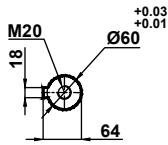

**Klemens Pozisyonları**  
Terminal Box Positions  
Klemmenkasten Positionen

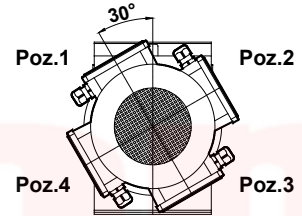

100-112-132-160-180-200  
Tip / Type / Typ

	100L/B5	112M/B5	132S/B5	132M/B5	160M/B5	160L/B5	180M/B5	180L/B5	200L/B5
k	790	810	875	913	1060	1104	1117	1155	1227
k1	925	945	1020	1058	1230	1274	1287	1325	1427
n	194	218	258	258	310	310	348	348	390
n1	135	146	168	168	225	225	241	241	275
x	-	-	-	-	-	-	-	-	0.5

#### KV573.05

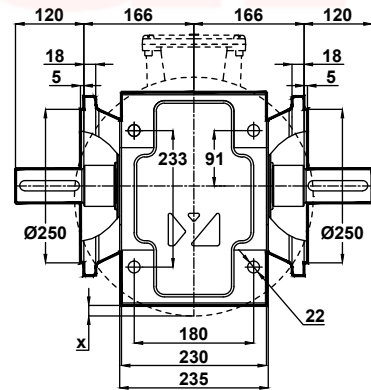
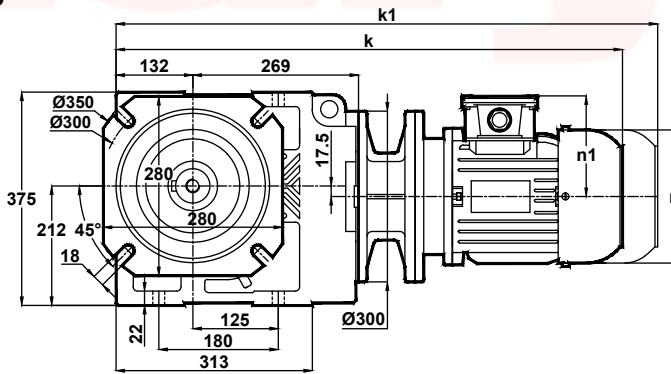

x: Motor Ayak bağlantı yüzeyinin altında ise  
x: If Motor is lower then foot mounting plane  
x: Wenn motor ist niedriger den die Anschlußplatte

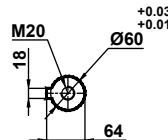

	100L/B5	112M/B5	132S/B5	132M/B5	160M/B5	160L/B5	180M/B5	180L/B5	200L/B5
k	790	810	875	913	1060	1104	1117	1155	1227
k1	925	945	1020	1058	1230	1274	1287	1325	1427
n	194	218	258	258	310	310	348	348	390
n1	135	146	168	168	225	225	241	241	275
x	-	-	-	-	-	-	-	-	0.5



# Ölçü Sayfaları Dimension Pages Abmessungsseiten



-Mil ucu çekirme deliği DIN 332 sayfa 2 / Tapped center hole to DIN 332, sheet 2 / Zentrierung mit gewinde DIN 332, Blatt 2

KV573.08

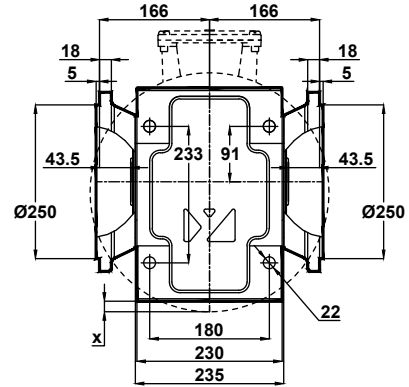
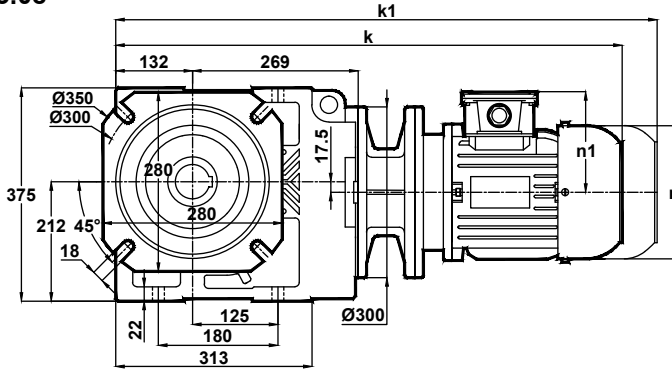

Std.

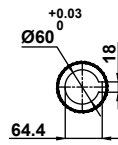

Ops.

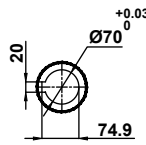

x: Motor Ayak bağlantı yüzeyinin altında ise  
x: If Motor is lower then foot mounting plane  
x: Wenn motor ist niedriger den die Anschlußplatte

Klemens Pozisyonları  
Terminal Box Positions  
Klemmenkasten Positionen

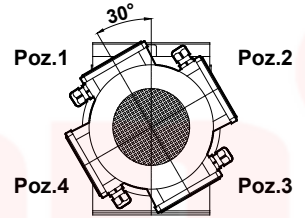

100-112-132-160-180-200  
Tip / Type / Typ

	100L/B5	112M/B5	132S/B5	132M/B5	160M/B5	160L/B5	180M/B5	180L/B5	200L/B5
k	790	810	875	913	1060	1104	1117	1155	1227
k1	925	945	1020	1058	1230	1274	1287	1325	1427
n	194	218	258	258	310	310	348	348	390
n1	135	146	168	168	225	225	241	241	275
x	-	-	-	-	-	-	-	-	0.5



# Ölçü Sayfaları Dimension Pages Abmessungenseiten



-Mil ucu çektirme deliği DIN 332 sayfa 2 / Tapped center hole to DIN 332, sheet 2 / Zentrierung mit gewinde DIN 332, Blatt 2

## KV574.00

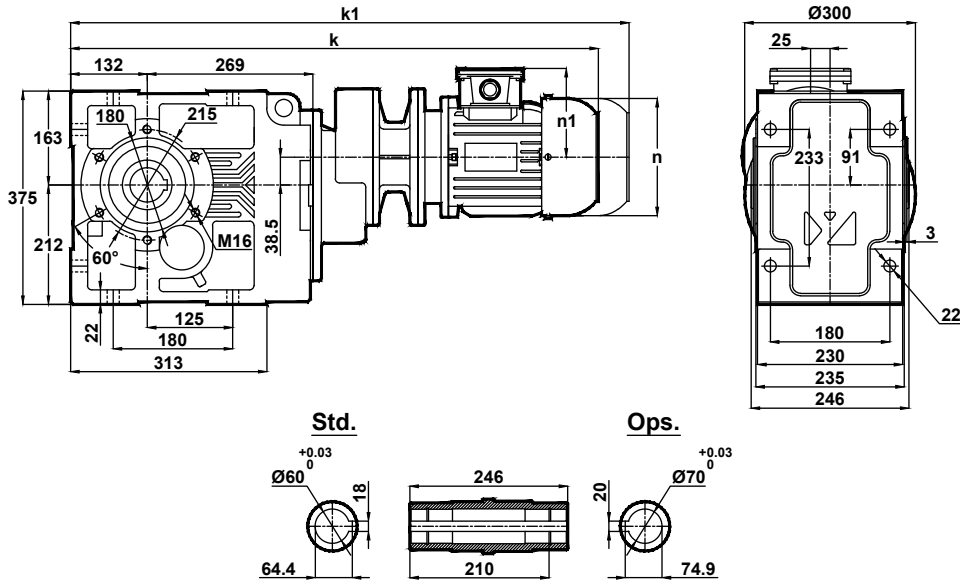

**Klemens Pozisyonları**  
Terminal Box Positions  
Klemmenkasten Positionen

	71/B5	80/B5	90S/B5	90L/B5	100L/B5	112M/B5	132S/B5	132M/B5
<b>k</b>	773	793	813	838	887	907	971	1009
<b>k1</b>	893	913	938	963	1022	1042	1116	1154
<b>n</b>	138	156	176	176	194	218	258	258
<b>n1</b>	110	118	126	126	135	146	168	168

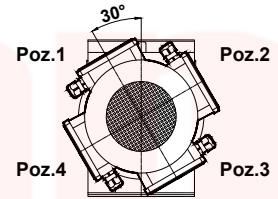

71-80-90-100-112-132  
Tip / Type / Typ

## KV574.01

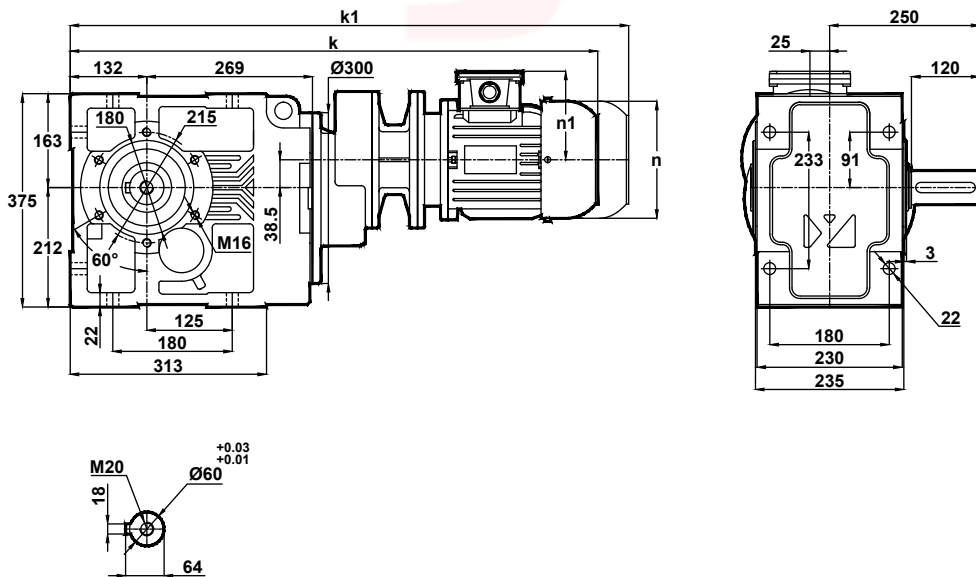

	71/B5	80/B5	90S/B5	90L/B5	100L/B5	112M/B5	132S/B5	132M/B5
<b>k</b>	773	793	813	838	887	907	971	1009
<b>k1</b>	893	913	938	963	1022	1042	1116	1154
<b>n</b>	138	156	176	176	194	218	258	258
<b>n1</b>	110	118	126	126	135	146	168	168



# Ölçü Sayfaları Dimension Pages Abmessungenseiten



-Mil ucu çekirme deliği DIN 332 sayfa 2 / Tapped center hole to DIN 332, sheet 2 / Zentrierung mit gewinde DIN 332, Blatt 2

## KV574.02

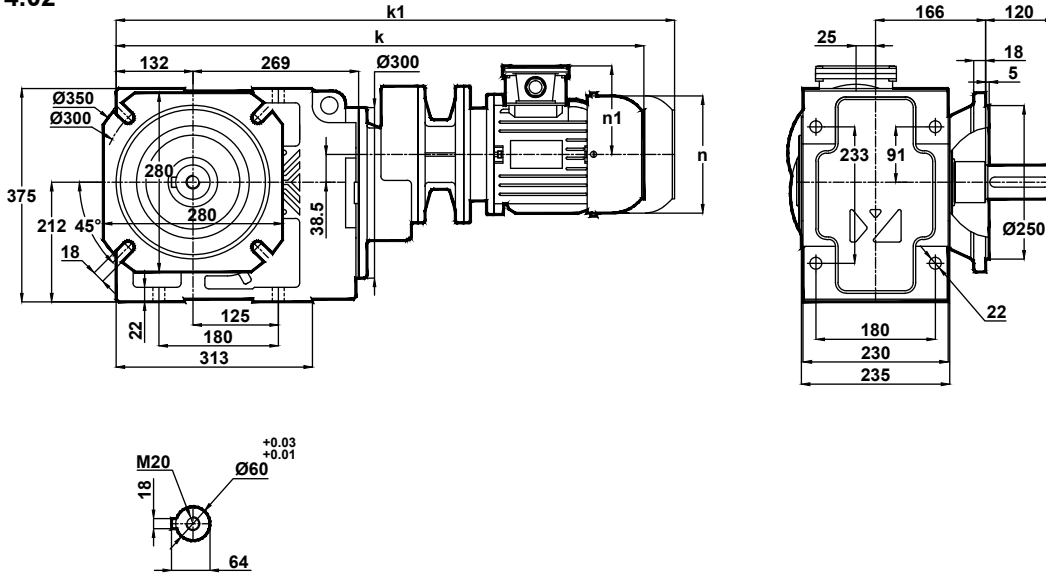

Klemens Pozisyonları  
Terminal Box Positions  
Klemmenkasten Positionen

	71/B5	80/B5	90S/B5	90L/B5	100L/B5	112M/B5	132S/B5	132M/B5
k	773	793	813	838	887	907	971	1009
k1	893	913	938	963	1022	1042	1116	1154
n	138	156	176	176	194	218	258	258
n1	110	118	126	126	135	146	168	168

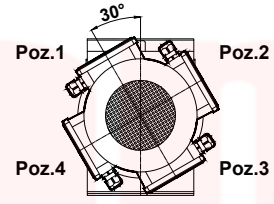

71-80-90-100-112-132  
Tip / Type / Typ

## KV574.03

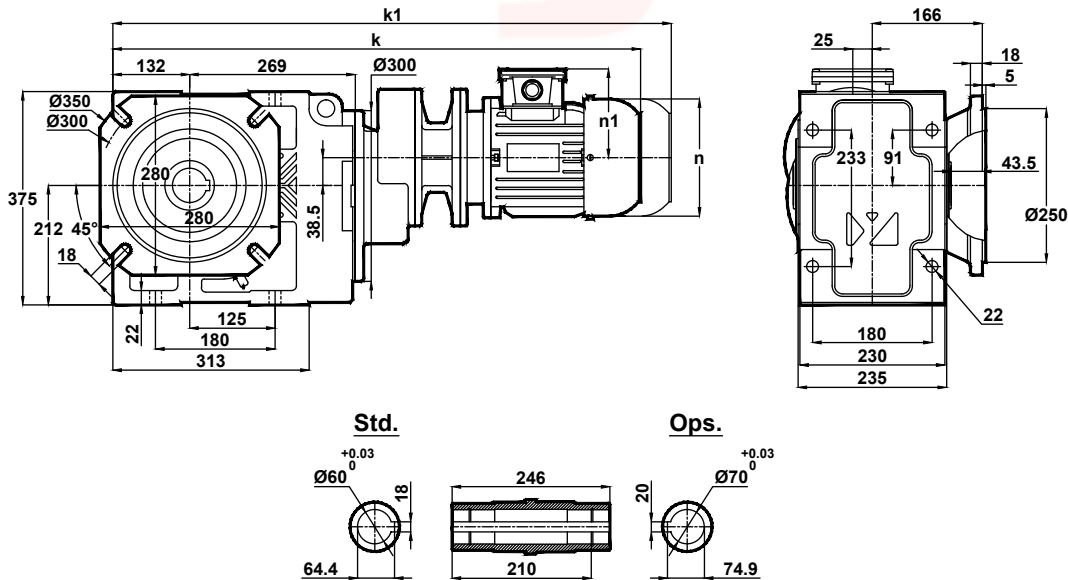

Std.

Ops.

	71/B5	80/B5	90S/B5	90L/B5	100L/B5	112M/B5	132S/B5	132M/B5
k	773	793	813	838	887	907	971	1009
k1	893	913	938	963	1022	1042	1116	1154
n	138	156	176	176	194	218	258	258
n1	110	118	126	126	135	146	168	168



# Ölçü Sayfaları Dimension Pages Abmessungenseiten



-Mil ucu çektirme deliği DIN 332 sayfa 2 / Tapped center hole to DIN 332, sheet 2 / Zentrierung mit gewinde DIN 332, Blatt 2

## KV574.04

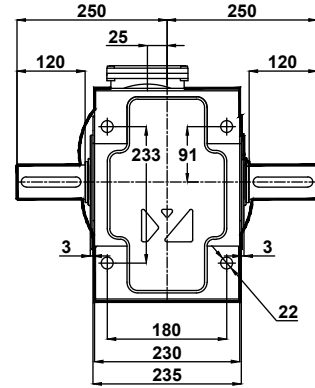
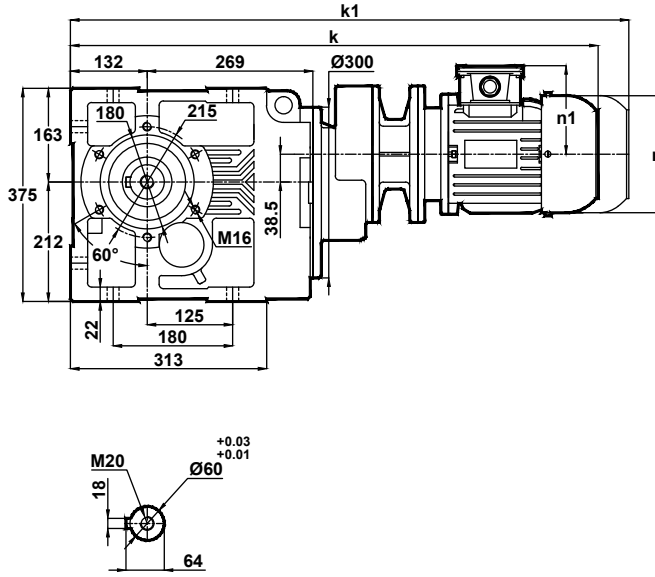

Klemens Pozisyonları  
Terminal Box Positions  
Klemmenkasten Positionen

	71/B5	80/B5	90S/B5	90L/B5	100L/B5	112M/B5	132S/B5	132M/B5
k	773	793	813	838	887	907	971	1009
k1	893	913	938	963	1022	1042	1116	1154
n	138	156	176	176	194	218	258	258
n1	110	118	126	126	135	146	168	168

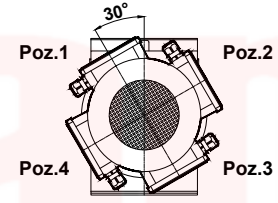

71-80-90-100-112-132  
Tip / Type / Typ

## KV574.05

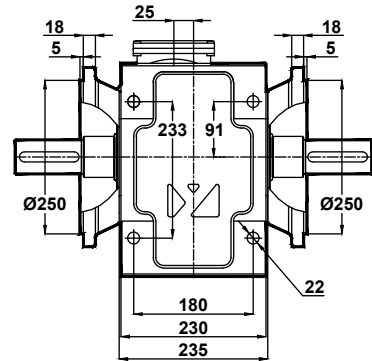
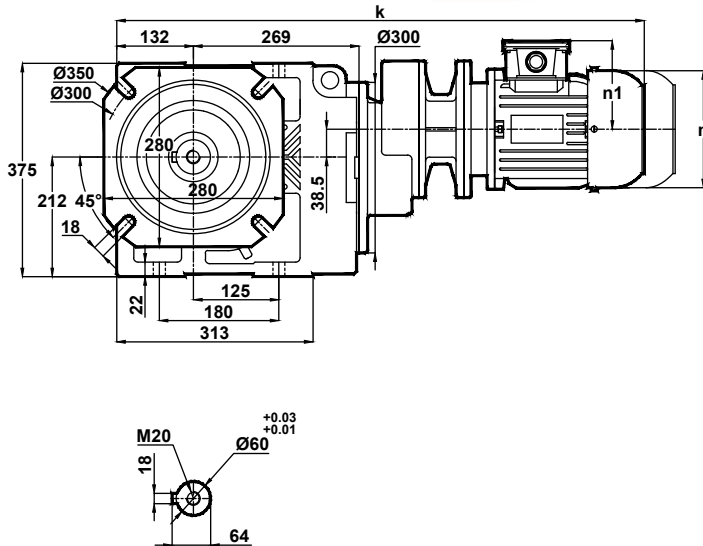

	71/B5	80/B5	90S/B5	90L/B5	100L/B5	112M/B5	132S/B5	132M/B5
k	773	793	813	838	887	907	971	1009
k1	893	913	938	963	1022	1042	1116	1154
n	138	156	176	176	194	218	258	258
n1	110	118	126	126	135	146	168	168



# Ölçü Sayfaları Dimension Pages Abmessungsseiten



-Mil ucu çekirme deliği DIN 332 sayfa 2 / Tapped center hole to DIN 332, sheet 2 / Zentrierung mit gewinde DIN 332, Blatt 2

KV574.08

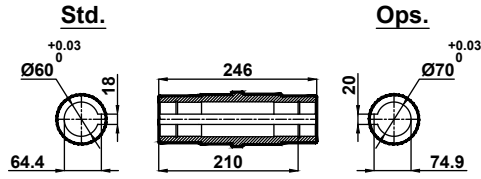
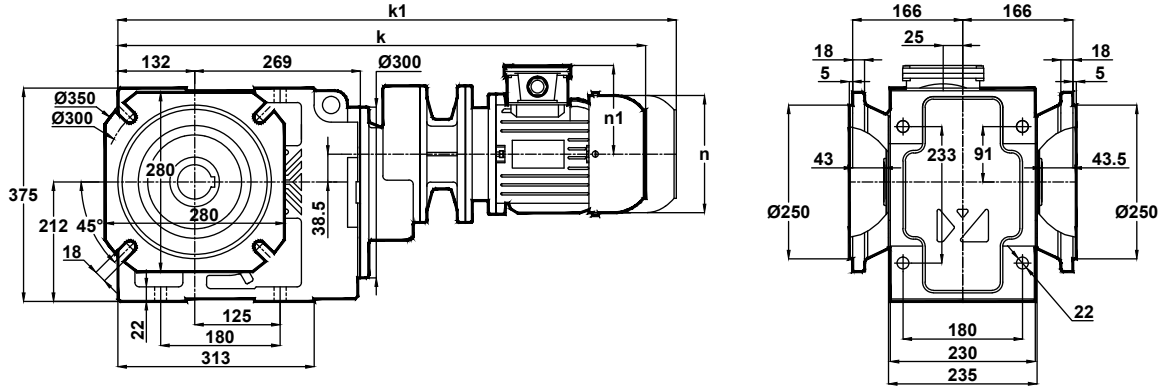

Klemens Pozisyonları  
Terminal Box Positions  
Klemmenkasten Positionen

	71/B5	80/B5	90S/B5	90L/B5	100L/B5	112M/B5	132S/B5	132M/B5
k	773	793	813	838	887	907	971	1009
k1	893	913	938	963	1022	1042	1116	1154
n	138	156	176	176	194	218	258	258
n1	110	118	126	126	135	146	168	168

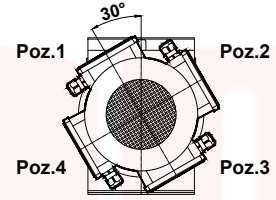

71-80-90-100-112-132  
Tip / Type / Typ



# Ölçü Sayfaları Dimension Pages Abmessungenseiten



-Mil ucu çektirme deliği DIN 332 sayfa 2 / Tapped center hole to DIN 332, sheet 2 / Zentrierung mit gewinde DIN 332, Blatt 2

KV575.00  
KV576.00

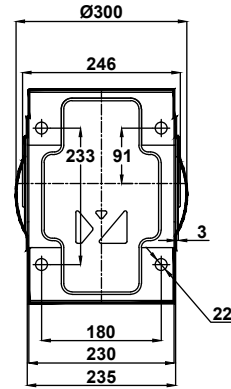
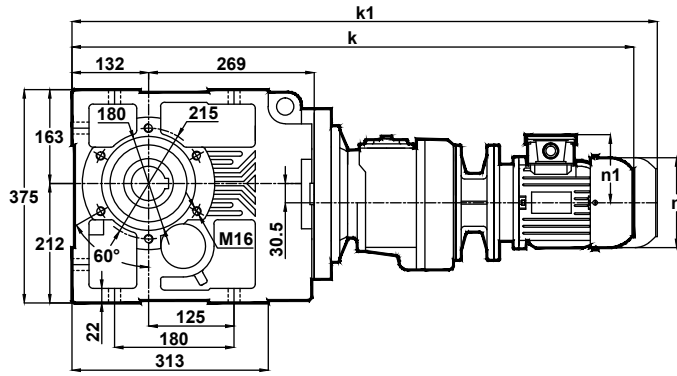

Std.

Ops.

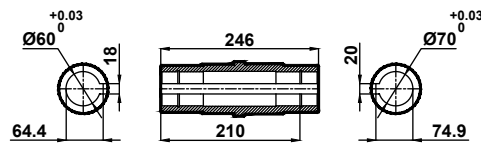

Klemens Pozisyonları  
Terminal Box Positions  
Klemmenkasten Positionen

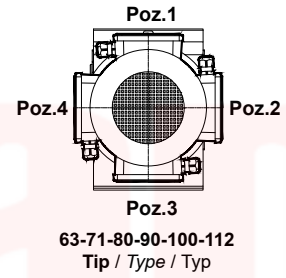

	63/B5	71/B5	80/B5	90S/B5	90L/B5	100L/B5	112M/B5
k	877	874	923	943	968	993	1013
k1	-	994	1043	1068	1093	1128	1148
n	116	138	156	176	176	194	218
n1	97	110	118	126	126	135	146

KV575.01  
KV576.01

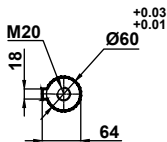
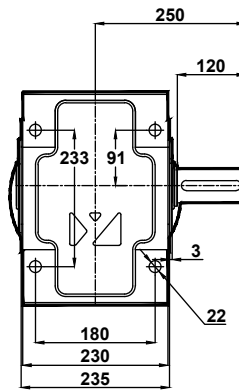
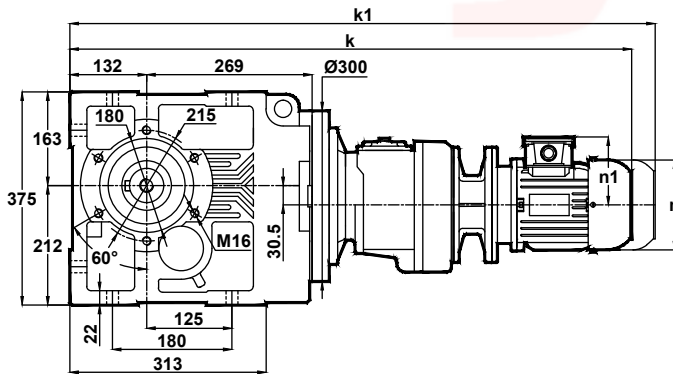

	63/B5	71/B5	80/B5	90S/B5	90L/B5	100L/B5	112M/B5
k	877	874	923	943	968	993	1013
k1	-	994	1043	1068	1093	1128	1148
n	116	138	156	176	176	194	218
n1	97	110	118	126	126	135	146





# Ölçü Sayfaları Dimension Pages Abmessungsseiten



-Mil ucu çekirme deliği DIN 332 sayfa 2 / Tapped center hole to DIN 332, sheet 2 / Zentrierung mit gewinde DIN 332, Blatt 2

KV575.02  
KV576.02

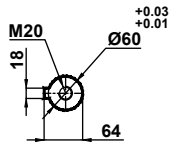
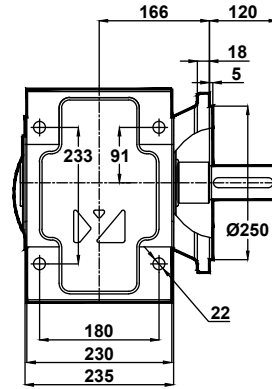
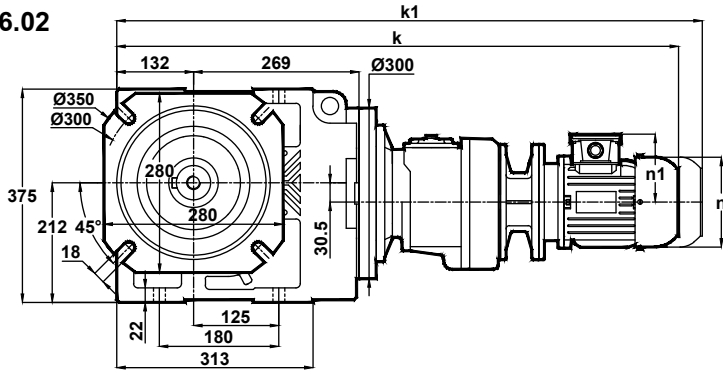

Klemens Pozisyonları  
Terminal Box Positions  
Klemmenkasten Positionen

	63/B5	71/B5	80/B5	90S/B5	90L/B5	100L/B5	112M/B5
k	877	874	923	943	968	993	1013
k1	-	994	1043	1068	1093	1128	1148
n	116	138	156	176	176	194	218
n1	97	110	118	126	126	135	146

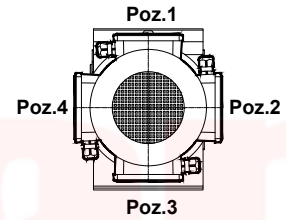

63-71-80-90-100-112  
Tip / Type / Typ

KV575.03  
KV576.03

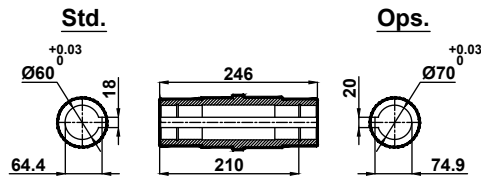
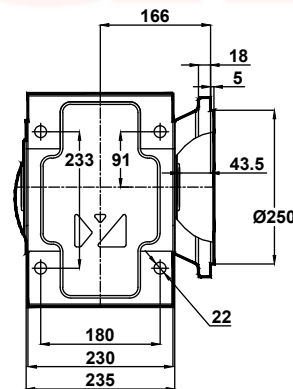
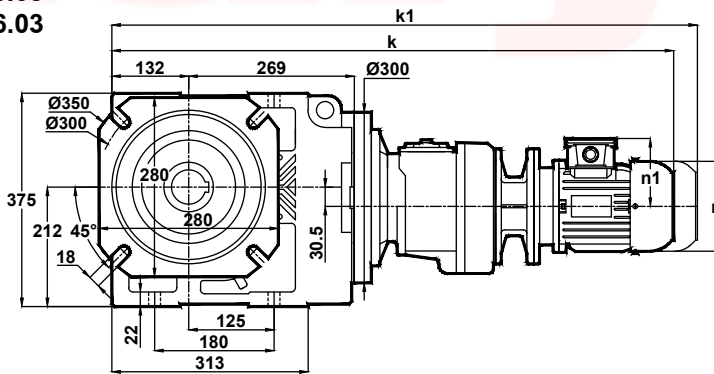

	63/B5	71/B5	80/B5	90S/B5	90L/B5	100L/B5	112M/B5
k	877	874	923	943	968	993	1013
k1	-	994	1043	1068	1093	1128	1148
n	116	138	156	176	176	194	218
n1	97	110	118	126	126	135	146



# Ölçü Sayfaları Dimension Pages Abmessungsseiten



-Mil ucu çektirme deliği DIN 332 sayfa 2 / Tapped center hole to DIN 332, sheet 2 / Zentrierung mit gewinde DIN 332, Blatt 2

KV575.04  
KV576.04

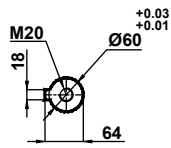
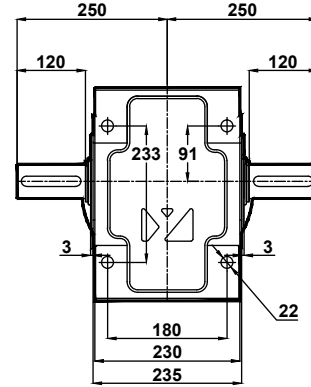
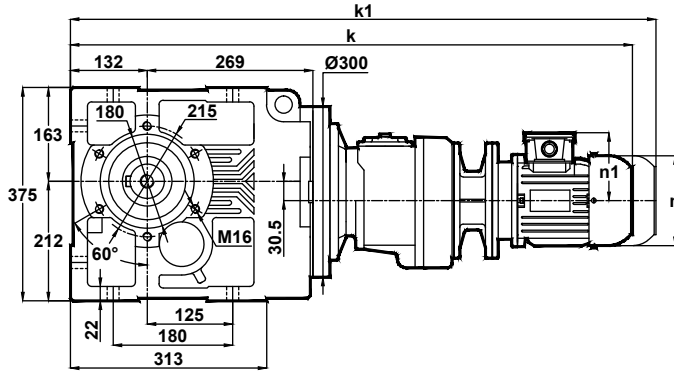

	63/B5	71/B5	80/B5	90S/B5	90L/B5	100L/B5	112M/B5
k	877	874	923	943	968	993	1013
k1	-	994	1043	1068	1093	1128	1148
n	116	138	156	176	176	194	218
n1	97	110	118	126	126	135	146

Klemens Pozisyonları  
Terminal Box Positions  
Klemmenkasten Positionen

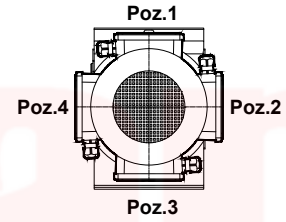

63-71-80-90-100-112  
Tip / Type / Typ

KV575.05  
KV576.05

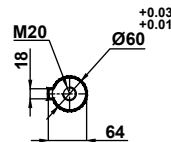
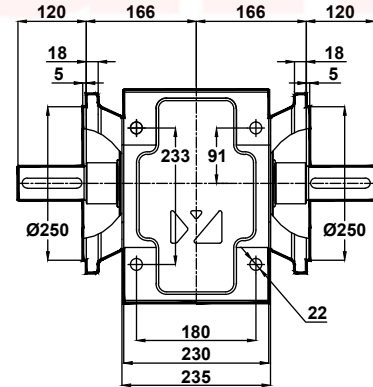
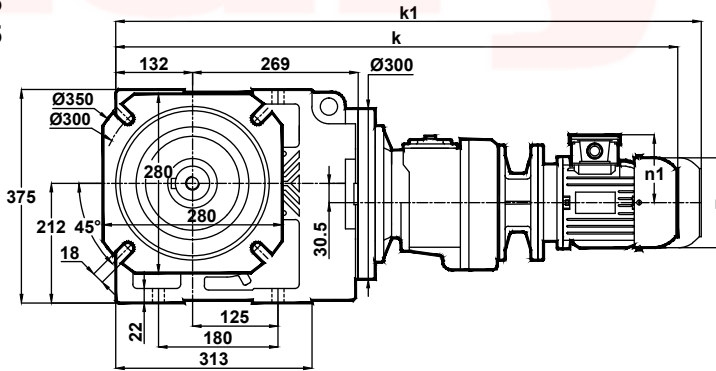

	63/B5	71/B5	80/B5	90S/B5	90L/B5	100L/B5	112M/B5
k	877	874	923	943	968	993	1013
k1	-	994	1043	1068	1093	1128	1148
n	116	138	156	176	176	194	218
n1	97	110	118	126	126	135	146



# Ölçü Sayfaları Dimension Pages Abmessungsseiten



-Mil ucu çektirme deliği DIN 332 sayfa 2 / Tapped center hole to DIN 332, sheet 2 / Zentrierung mit gewinde DIN 332, Blatt 2

KV575.08  
KV576.08

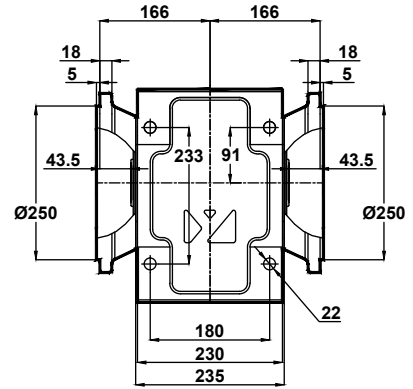
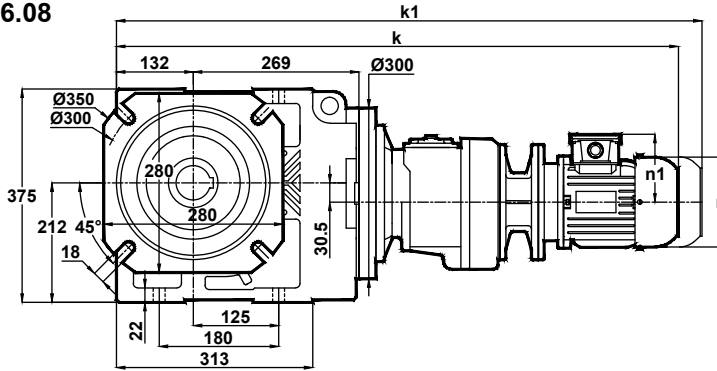

Std.

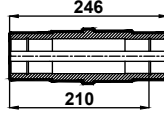
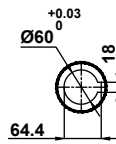

Ops.

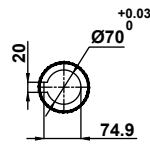

	63/B5	71/B5	80/B5	90S/B5	90L/B5	100L/B5	112M/B5
k	877	874	923	943	968	993	1013
k1	-	994	1043	1068	1093	1128	1148
n	116	138	156	176	176	194	218
n1	97	110	118	126	126	135	146

Klemens Pozisyonları  
Terminal Box Positions  
Klemmenkasten Positionen

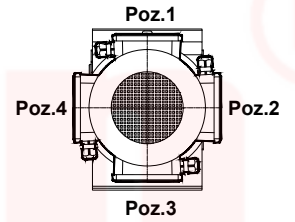

63-71-80-90-100-112  
Tip / Type / Typ



# Ölçü Sayfaları Dimension Pages Abmessungenseiten



-Mil ucu çekirme deliği DIN 332 sayfa 2 / Tapped center hole to DIN 332, sheet 2 / Zentrierung mit gewinde DIN 332, Blatt 2

## KV673.00

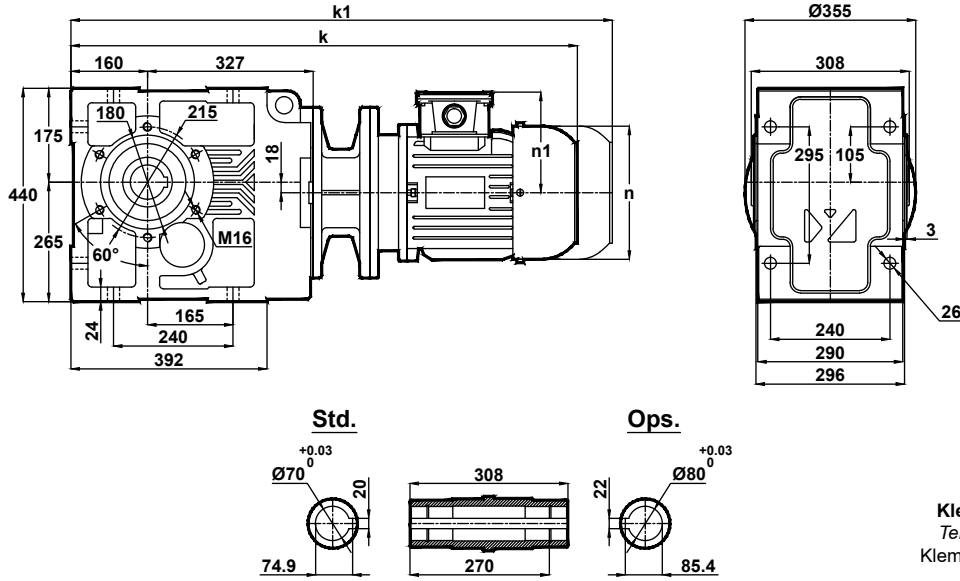

	100L/B5	112M/B5	132S/B5	132M/B5	160M/B5	160L/B5	180M/B5	180L/B5	200L/B5	225S/B5	225M/B5
k	872	892	951	989	1136	1180	1193	1231	1303	1374	1399
k1	1007	1027	1096	1134	1306	1350	1363	1401	1503	-	-
n	194	218	258	258	310	310	348	348	390	433	433
n1	135	146	168	168	225	225	241	241	275	285	285

Klemens Pozisyonları  
Terminal Box Positions  
Klemmenkasten Positionen

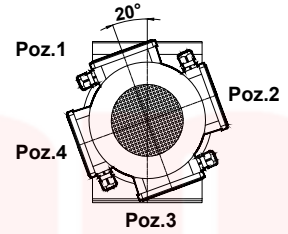

100-112-132-160-180-200-225  
Tip / Type / Typ

## KV673.01

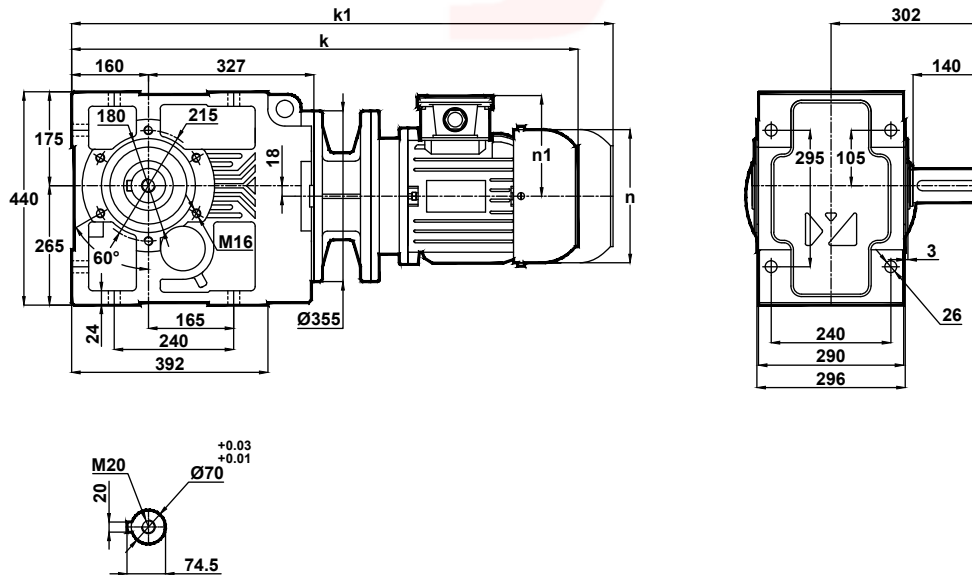

	100L/B5	112M/B5	132S/B5	132M/B5	160M/B5	160L/B5	180M/B5	180L/B5	200L/B5	225S/B5	225M/B5
k	872	892	951	989	1136	1180	1193	1231	1303	1374	1399
k1	1007	1027	1096	1134	1306	1350	1363	1401	1503	-	-
n	194	218	258	258	310	310	348	348	390	433	433
n1	135	146	168	168	225	225	241	241	275	285	285



# Ölçü Sayfaları Dimension Pages Abmessungsseiten



-Mil ucu çekirme deliği DIN 332 sayfa 2 / Tapped center hole to DIN 332, sheet 2 / Zentrierung mit gewinde DIN 332, Blatt 2

## KV673.02

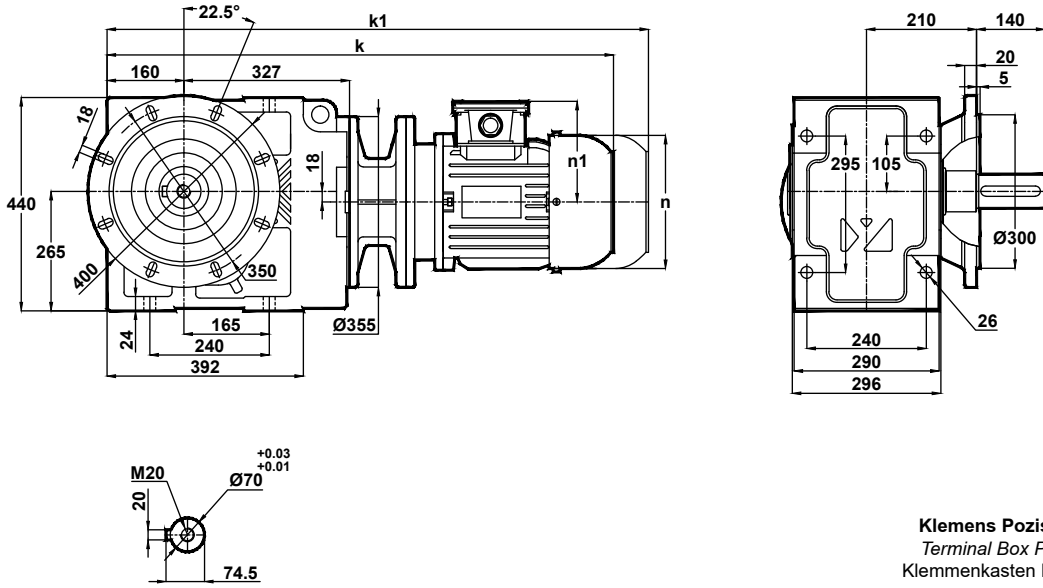

	100L/B5	112M/B5	132S/B5	132M/B5	160M/B5	160L/B5	180M/B5	180L/B5	200L/B5	225S/B5	225M/B5
k	872	892	951	989	1136	1180	1193	1231	1303	1374	1399
k1	1007	1027	1096	1134	1306	1350	1363	1401	1503	-	-
n	194	218	258	258	310	310	348	348	390	433	433
n1	135	146	168	168	225	225	241	241	275	285	285

Klemens Pozisyonları  
Terminal Box Positions  
Klemmenkasten Positionen

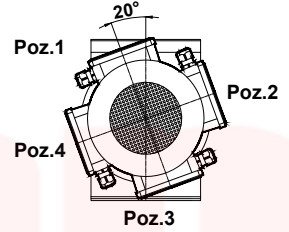

100-112-132-160-180-200-225  
Tip / Type / Typ

## KV673.03

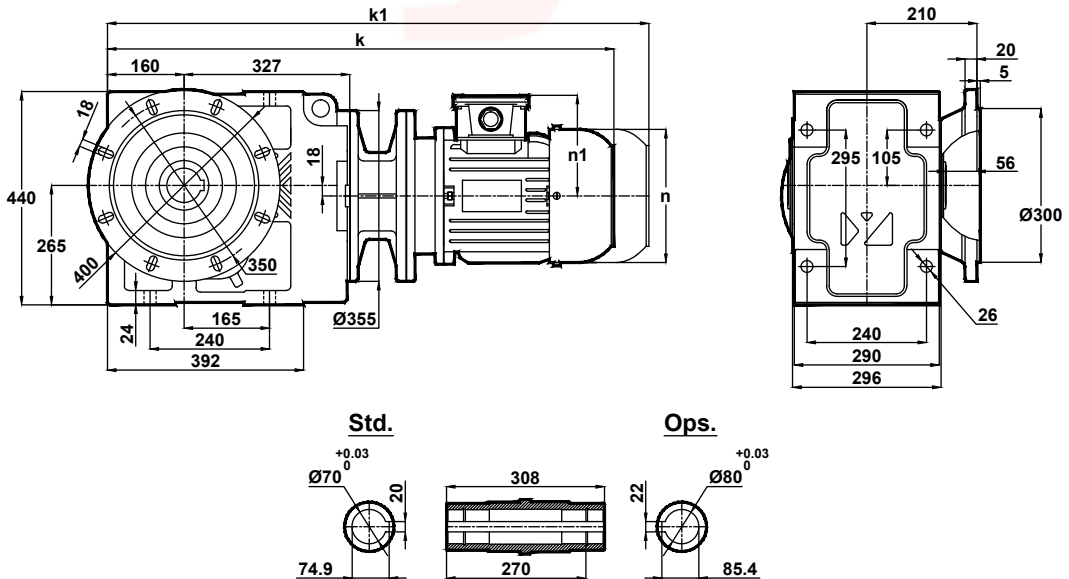

Std.

Ops.

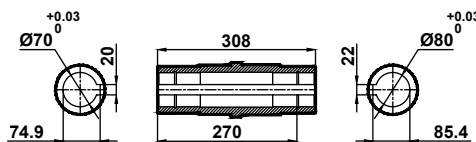

	100L/B5	112M/B5	132S/B5	132M/B5	160M/B5	160L/B5	180M/B5	180L/B5	200L/B5	225S/B5	225M/B5
k	872	892	951	989	1136	1180	1193	1231	1303	1374	1399
k1	1007	1027	1096	1134	1306	1350	1363	1401	1503	-	-
n	194	218	258	258	310	310	348	348	390	433	433
n1	135	146	168	168	225	225	241	241	275	285	285



# Ölçü Sayfaları

## Dimension Pages

### Abmessungsseiten



-Mil ucu çekirme deliği DIN 332 sayfa 2 / Tapped center hole to DIN 332, sheet 2 / Zentrierung mit gewinde DIN 332, Blatt 2

#### KV673.04

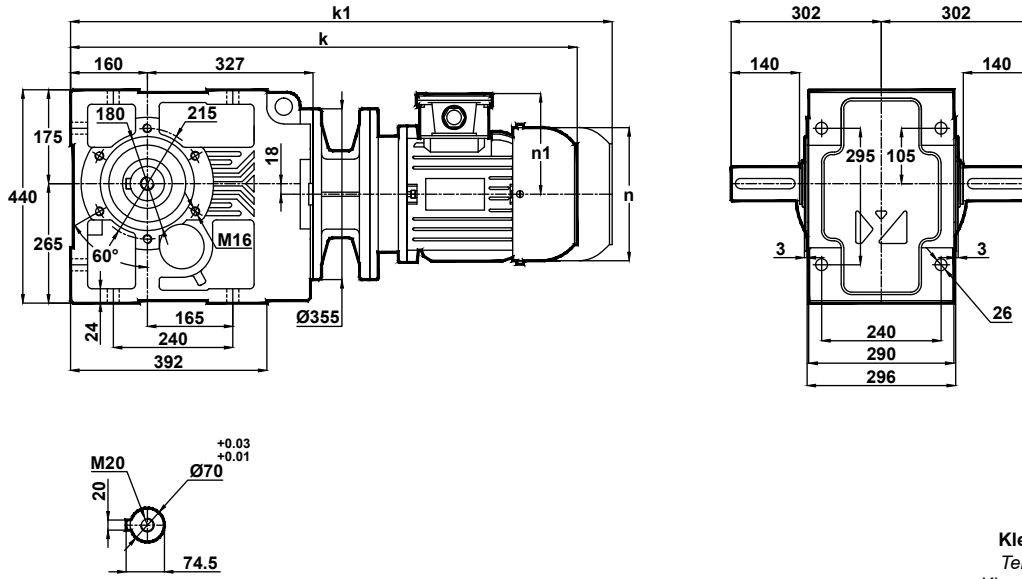

**Klemens Pozisyonları**  
Terminal Box Positions  
Klemmenkasten Positionen

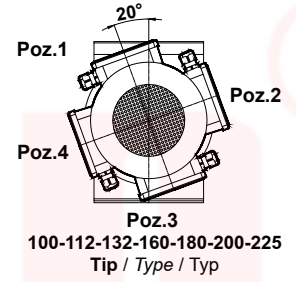

**Poz.3**  
100-112-132-160-180-200-225  
Tip / Type / Typ

	100L/B5	112M/B5	132S/B5	132M/B5	160M/B5	160L/B5	180M/B5	180L/B5	200L/B5	225S/B5	225M/B5
<b>k</b>	872	892	951	989	1136	1180	1193	1231	1303	1374	1399
<b>k1</b>	1007	1027	1096	1134	1306	1350	1363	1401	1503	-	-
<b>n</b>	194	218	258	258	310	310	348	348	390	433	433
<b>n1</b>	135	146	168	168	225	225	241	241	275	285	285

#### KV673.05

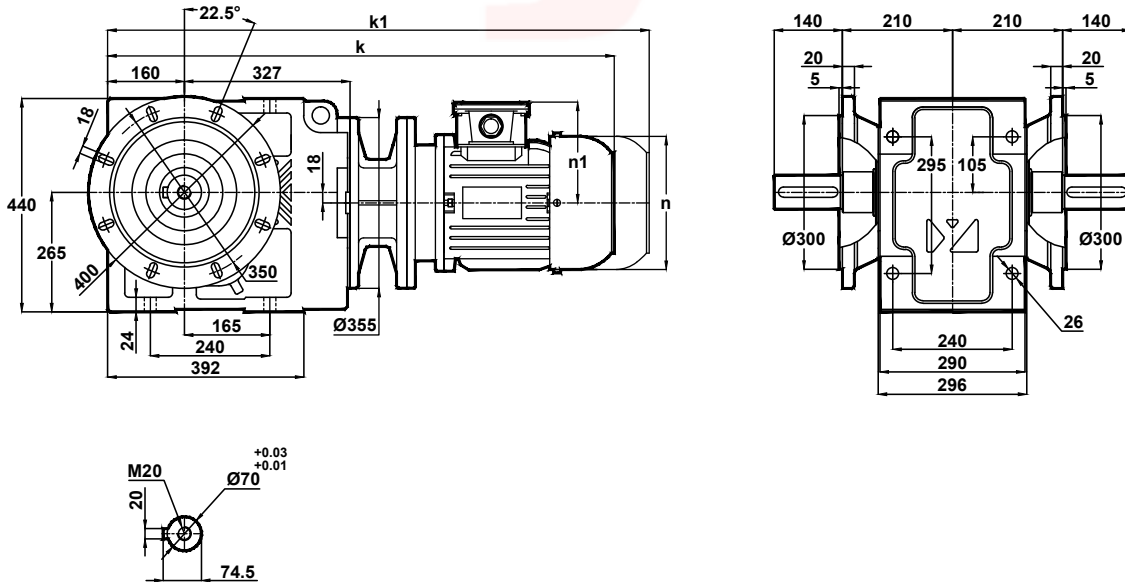

	100L/B5	112M/B5	132S/B5	132M/B5	160M/B5	160L/B5	180M/B5	180L/B5	200L/B5	225S/B5	225M/B5
<b>k</b>	872	892	951	989	1136	1180	1193	1231	1303	1374	1399
<b>k1</b>	1007	1027	1096	1134	1306	1350	1363	1401	1503	-	-
<b>n</b>	194	218	258	258	310	310	348	348	390	433	433
<b>n1</b>	135	146	168	168	225	225	241	241	275	285	285



# Ölçü Sayfaları Dimension Pages Abmessungsseiten



-Mil ucu çekirme deliği DIN 332 sayfa 2 / Tapped center hole to DIN 332, sheet 2 / Zentrierung mit gewinde DIN 332, Blatt 2

KV673.08

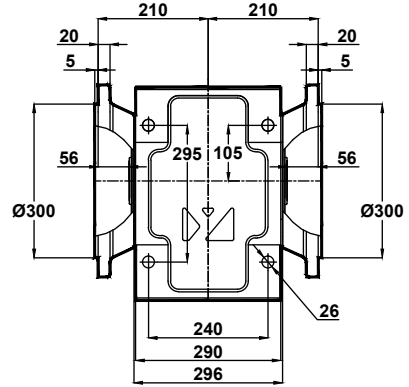
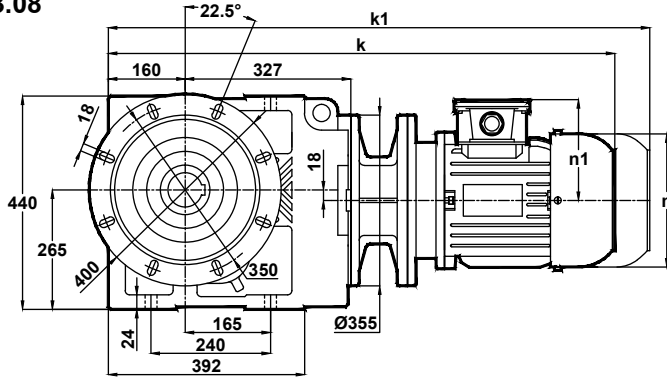

Std.

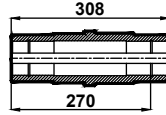
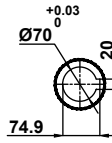

Ops.

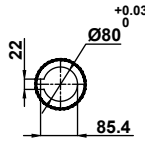

Klemens Pozisyonları  
Terminal Box Positions  
Klemmenkasten Positionen

	100L/B5	112M/B5	132S/B5	132M/B5	160M/B5	160L/B5	180M/B5	180L/B5	200L/B5	225S/B5	225M/B5
k	872	892	951	989	1136	1180	1193	1231	1303	1374	1399
k1	1007	1027	1096	1134	1306	1350	1363	1401	1503	-	-
n	194	218	258	258	310	310	348	348	390	433	433
n1	135	146	168	168	225	225	241	241	275	285	285

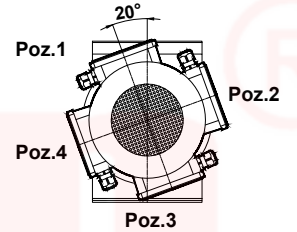

100-112-132-160-180-200-225  
Tip / Type / Typ



# Ölçü Sayfaları Dimension Pages Abmessungenseiten



-Mil ucu çektirme deliği DIN 332 sayfa 2 / Tapped center hole to DIN 332, sheet 2 / Zentrierung mit gewinde DIN 332, Blatt 2

## KV674.00

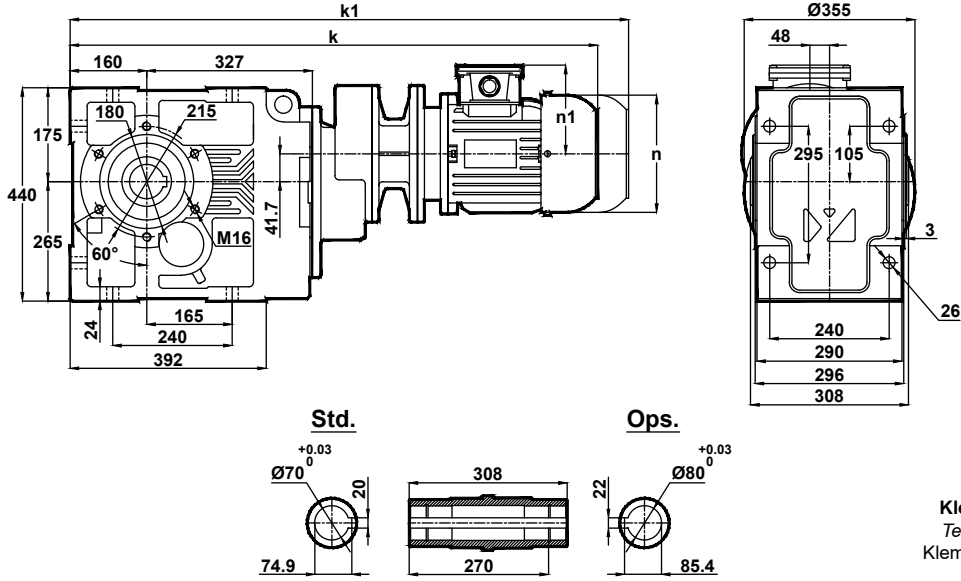

**Klemens Pozisyonları**  
Terminal Box Positions  
Klemmenkasten Positionen

	80/B5	90S/B5	90L/B5	100L/B5	112M/B5	132S/B5	132M/B5	160M/B5	160L/B5	180M/B5	180L/B5
<b>k</b>	885	905	930	980	1000	1063	1101	1252	1296	1309	1347
<b>k1</b>	1005	1030	1055	1115	1135	1208	1246	1422	1466	1479	1517
<b>n</b>	156	176	176	194	218	258	258	310	310	348	348
<b>n1</b>	118	126	126	135	146	168	168	225	225	241	241

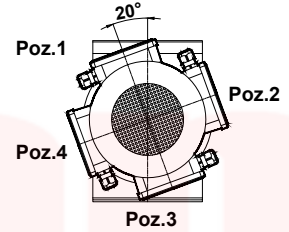

80-90-100-112-132-160-180  
Tip / Type / Typ

## KV674.01

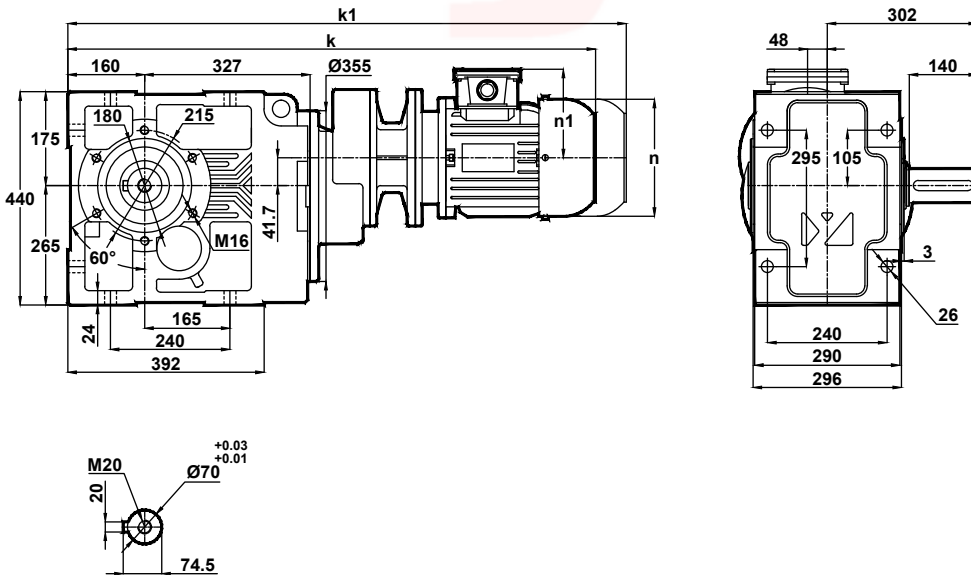

	80/B5	90S/B5	90L/B5	100L/B5	112M/B5	132S/B5	132M/B5	160M/B5	160L/B5	180M/B5	180L/B5
<b>k</b>	885	905	930	980	1000	1063	1101	1252	1296	1309	1347
<b>k1</b>	1005	1030	1055	1115	1135	1208	1246	1422	1466	1479	1517
<b>n</b>	156	176	176	194	218	258	258	310	310	348	348
<b>n1</b>	118	126	126	135	146	168	168	225	225	241	241





# Ölçü Sayfaları Dimension Pages Abmessungsseiten



-Mil ucu çektirme deliği DIN 332 sayfa 2 / Tapped center hole to DIN 332, sheet 2 / Zentrierung mit gewinde DIN 332, Blatt 2

## KV674.02

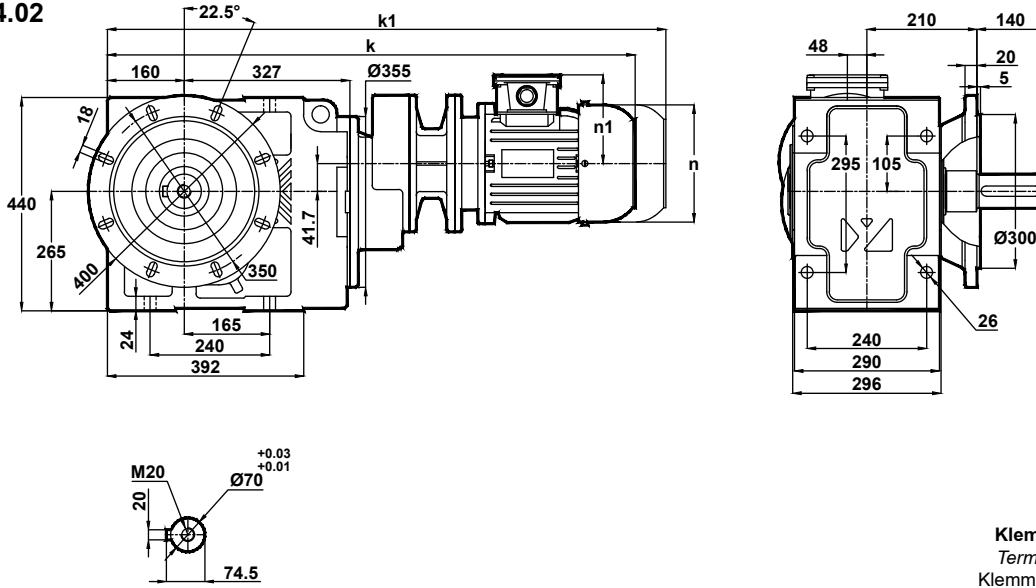

Klemens Pozisyonları  
Terminal Box Positions  
Klemmenkasten Positionen

	80/B5	90S/B5	90L/B5	100L/B5	112M/B5	132S/B5	132M/B5	160M/B5	160L/B5	180M/B5	180L/B5
k	885	905	930	980	1000	1063	1101	1252	1296	1309	1347
k1	1005	1030	1055	1115	1135	1208	1246	1422	1466	1479	1517
n	156	176	176	194	218	258	258	310	310	348	348
n1	118	126	126	135	146	168	168	225	225	241	241

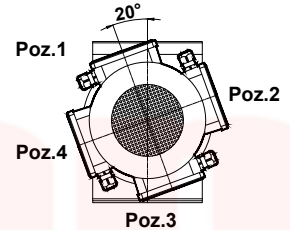

80-90-100-112-132-160-180  
Tip / Type / Typ

## KV674.03

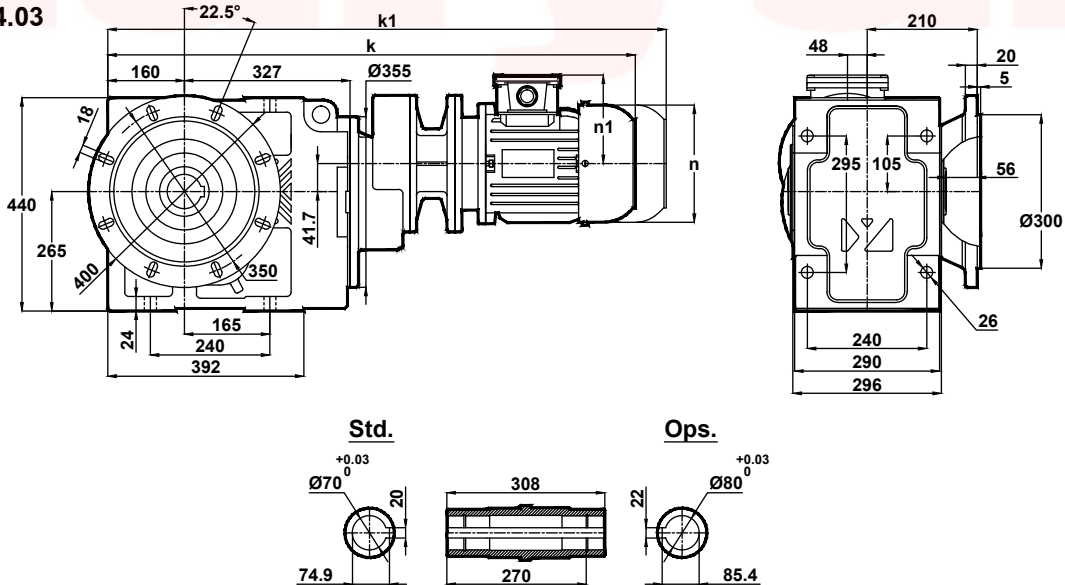

	80/B5	90S/B5	90L/B5	100L/B5	112M/B5	132S/B5	132M/B5	160M/B5	160L/B5	180M/B5	180L/B5
k	885	905	930	980	1000	1063	1101	1252	1296	1309	1347
k1	1005	1030	1055	1115	1135	1208	1246	1422	1466	1479	1517
n	156	176	176	194	218	258	258	310	310	348	348
n1	118	126	126	135	146	168	168	225	225	241	241



# Ölçü Sayfaları

## Dimension Pages

### Abmessungsseiten



-Mil ucu çekirme deliği DIN 332 sayfa 2 / Tapped center hole to DIN 332, sheet 2 / Zentrierung mit gewinde DIN 332, Blatt 2

#### KV674.04

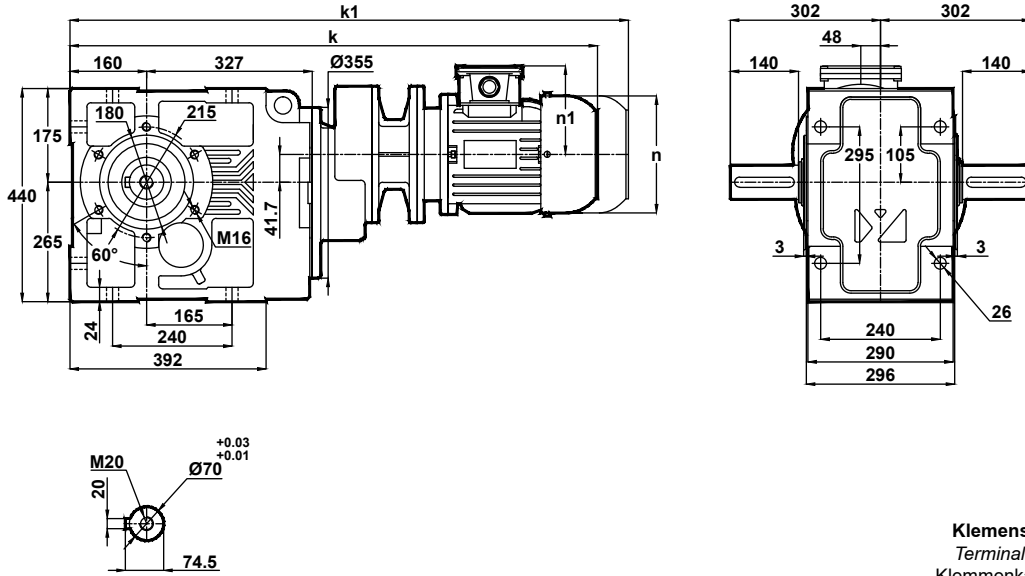

**Klemens Pozisyonları**  
Terminal Box Positions  
Klemmenkasten Positionen

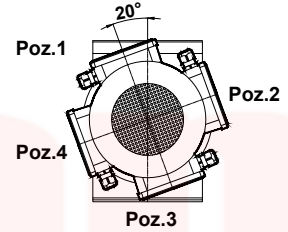

80-90-100-112-132-160-180  
Tip / Type / Typ

	80/B5	90S/B5	90L/B5	100L/B5	112M/B5	132S/B5	132M/B5	160M/B5	160L/B5	180M/B5	180L/B5
k	885	905	930	980	1000	1063	1101	1252	1296	1309	1347
k1	1005	1030	1055	1115	1135	1208	1246	1422	1466	1479	1517
n	156	176	176	194	218	258	258	310	310	348	348
n1	118	126	126	135	146	168	168	225	225	241	241

#### KV674.05

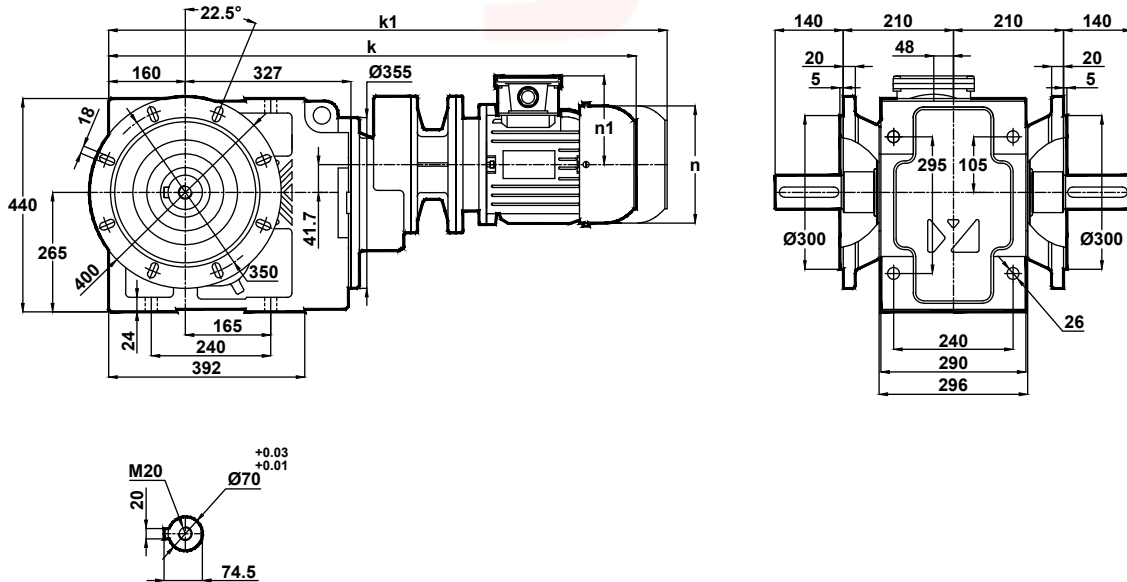

	80/B5	90S/B5	90L/B5	100L/B5	112M/B5	132S/B5	132M/B5	160M/B5	160L/B5	180M/B5	180L/B5
k	885	905	930	980	1000	1063	1101	1252	1296	1309	1347
k1	1005	1030	1055	1115	1135	1208	1246	1422	1466	1479	1517
n	156	176	176	194	218	258	258	310	310	348	348
n1	118	126	126	135	146	168	168	225	225	241	241



# Ölçü Sayfaları Dimension Pages Abmessungsseiten



-Mil ucu çektirme deliği DIN 332 sayfa 2 / Tapped center hole to DIN 332, sheet 2 / Zentrierung mit gewinde DIN 332, Blatt 2

KV674.08

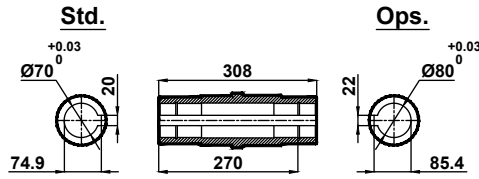
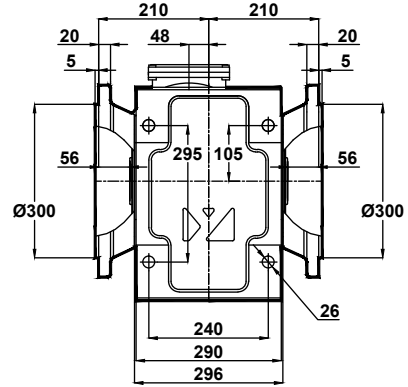
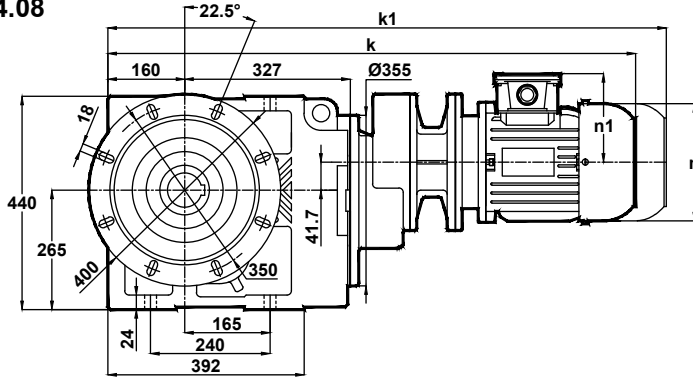

Klemens Pozisyonları  
Terminal Box Positions  
Klemmenkasten Positionen

	80/B5	90S/B5	90L/B5	100L/B5	112M/B5	132S/B5	132M/B5	160M/B5	160L/B5	180M/B5	180L/B5
k	885	905	930	980	1000	1063	1101	1252	1296	1309	1347
k1	1005	1030	1055	1115	1135	1208	1246	1422	1466	1479	1517
n	156	176	176	194	218	258	258	310	310	348	348
n1	118	126	126	135	146	168	168	225	225	241	241

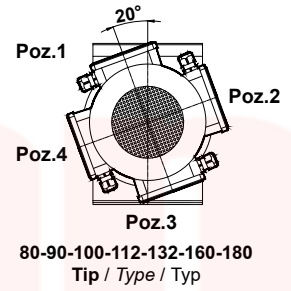



# Ölçü Sayfaları Dimension Pages Abmessungsseiten



-Mil ucu çekirme deliği DIN 332 sayfa 2 / Tapped center hole to DIN 332, sheet 2 / Zentrierung mit gewinde DIN 332, Blatt 2

KV675.00  
KV676.00

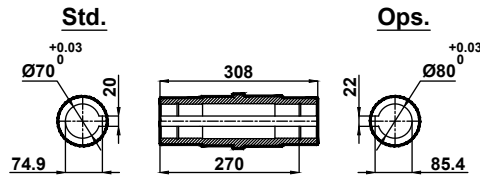
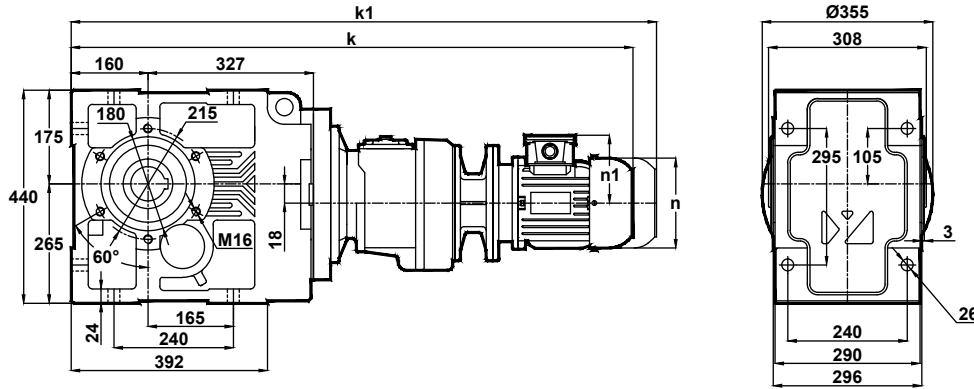

	71/B5	80/B5	90S/B5	90L/B5	100L/B5	112M/B5	132S/B5	132M/B5
k	1016	1036	1056	1081	1130	1150	1214	1252
k1	1136	1156	1181	1206	1265	1285	1359	1397
n	138	156	176	176	194	218	258	258
n1	110	118	126	126	135	146	168	168

Klemens Pozisyonları  
Terminal Box Positions  
Klemmenkasten Positionen

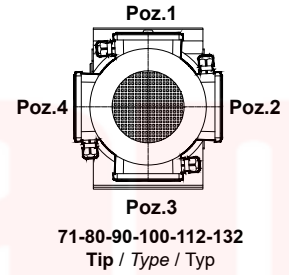

KV675.01  
KV676.01

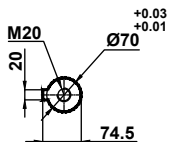
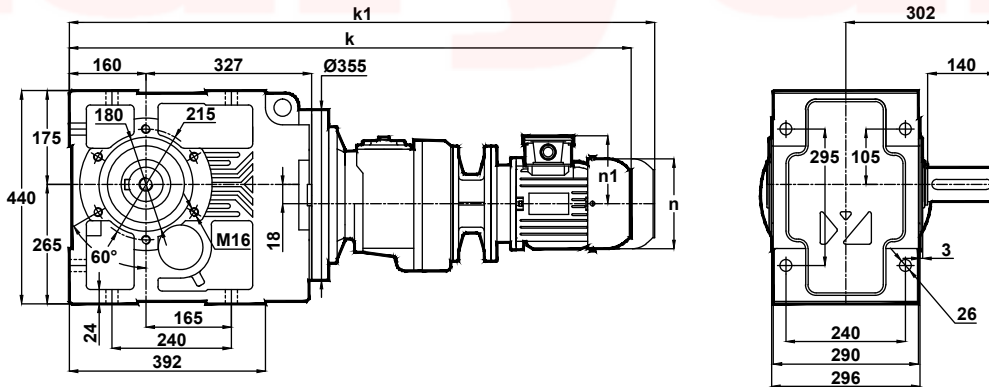

	71/B5	80/B5	90S/B5	90L/B5	100L/B5	112M/B5	132S/B5	132M/B5
k	1016	1036	1056	1081	1130	1150	1214	1252
k1	1136	1156	1181	1206	1265	1285	1359	1397
n	138	156	176	176	194	218	258	258
n1	110	118	126	126	135	146	168	168



# Ölçü Sayfaları Dimension Pages Abmessungsseiten



-Mil ucu çektirme deliği DIN 332 sayfa 2 / Tapped center hole to DIN 332, sheet 2 / Zentrierung mit gewinde DIN 332, Blatt 2

KV675.02  
KV676.02

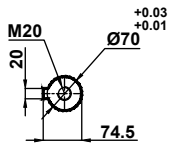
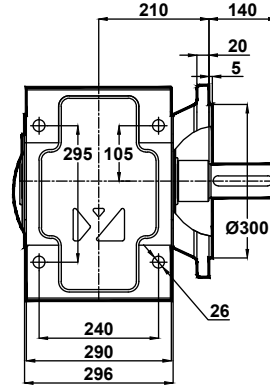
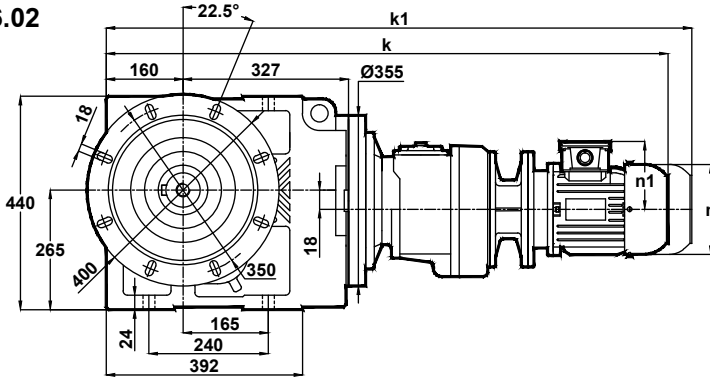

	71/B5	80/B5	90S/B5	90L/B5	100L/B5	112M/B5	132S/B5	132M/B5
k	1016	1036	1056	1081	1130	1150	1214	1252
k1	1136	1156	1181	1206	1265	1285	1359	1397
n	138	156	176	176	194	218	258	258
n1	110	118	126	126	135	146	168	168

Klemens Pozisyonları  
Terminal Box Positions  
Klemmenkasten Positionen

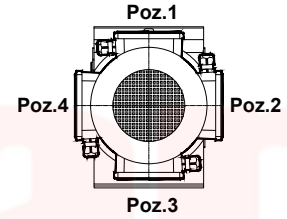

71-80-90-100-112-132  
Tip / Type / Typ

KV675.03  
KV676.03

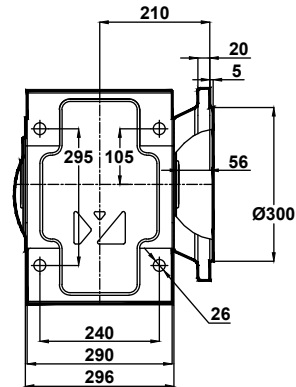
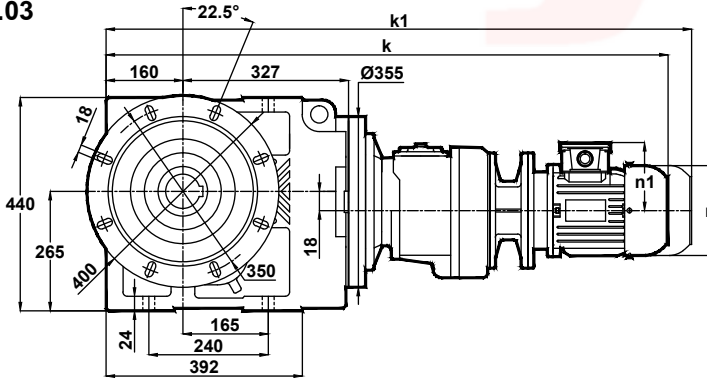

Std.

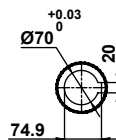

Ops.

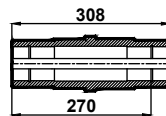
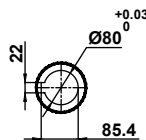

	71/B5	80/B5	90S/B5	90L/B5	100L/B5	112M/B5	132S/B5	132M/B5
k	1016	1036	1056	1081	1130	1150	1214	1252
k1	1136	1156	1181	1206	1265	1285	1359	1397
n	138	156	176	176	194	218	258	258
n1	110	118	126	126	135	146	168	168



# Ölçü Sayfaları

## Dimension Pages

### Abmessungsseiten



-Mil ucu çektirme deliği DIN 332 sayfa 2 / Tapped center hole to DIN 332, sheet 2 / Zentrierung mit gewinde DIN 332, Blatt 2

**KV675.04**  
**KV676.04**

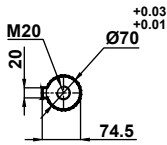
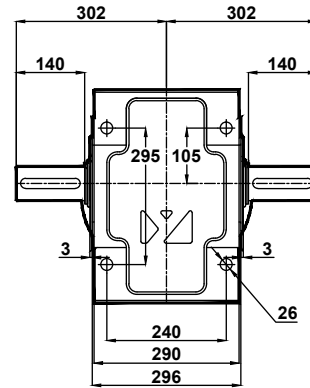
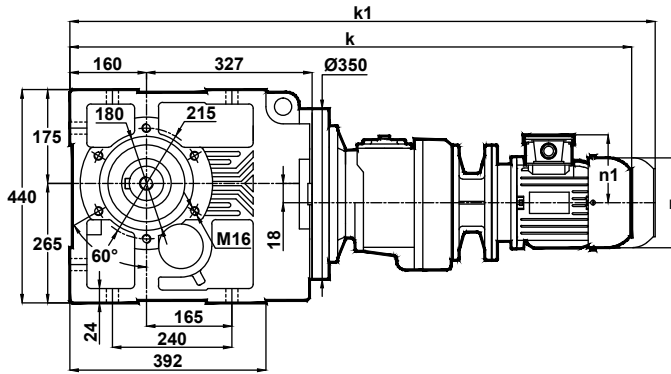

**Klemens Pozisyonları**  
*Terminal Box Positions*  
Klemmenkasten Positionen

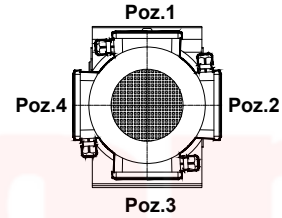

71-80-90-100-112-132  
Tip / Type / Typ

	71/B5	80/B5	90S/B5	90L/B5	100L/B5	112M/B5	132S/B5	132M/B5
<b>k</b>	1016	1036	1056	1081	1130	1150	1214	1252
<b>k1</b>	1136	1156	1181	1206	1265	1285	1359	1397
<b>n</b>	138	156	176	176	194	218	258	258
<b>n1</b>	110	118	126	126	135	146	168	168

**KV675.05**  
**KV676.05**

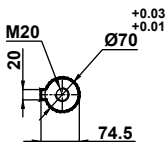
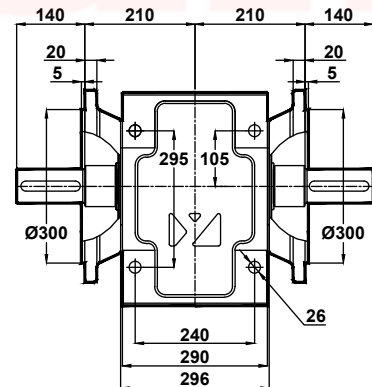
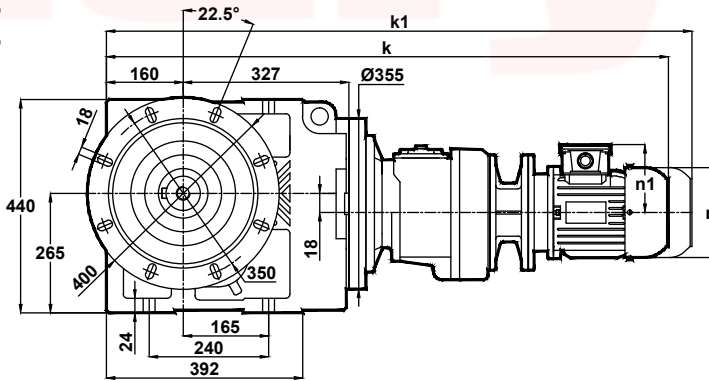

	71/B5	80/B5	90S/B5	90L/B5	100L/B5	112M/B5	132S/B5	132M/B5
<b>k</b>	1016	1036	1056	1081	1130	1150	1214	1252
<b>k1</b>	1136	1156	1181	1206	1265	1285	1359	1397
<b>n</b>	138	156	176	176	194	218	258	258
<b>n1</b>	110	118	126	126	135	146	168	168



# Ölçü Sayfaları Dimension Pages Abmessungsseiten



-Mil ucu çektirme deliği DIN 332 sayfa 2 / Tapped center hole to DIN 332, sheet 2 / Zentrierung mit gewinde DIN 332, Blatt 2

KV675.08  
KV676.08

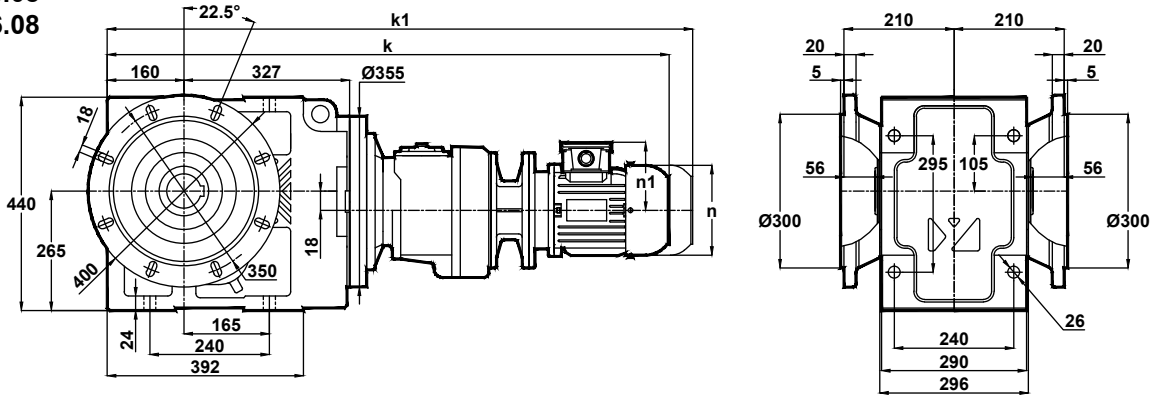

Std.

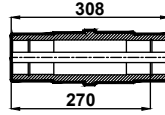
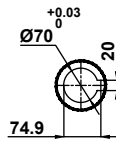

Ops.

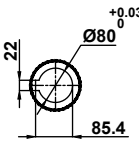

Klemens Pozisyonları  
Terminal Box Positions  
Klemmenkasten Positionen

	71/B5	80/B5	90S/B5	90L/B5	100L/B5	112M/B5	132S/B5	132M/B5
k	1016	1036	1056	1081	1130	1150	1214	1252
k1	1136	1156	1181	1206	1265	1285	1359	1397
n	138	156	176	176	194	218	258	258
n1	110	118	126	126	135	146	168	168

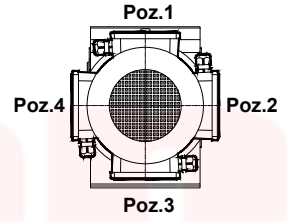

71-80-90-100-112-132  
Tip / Type / Typ



# Ölçü Sayfaları Dimension Pages Abmessungsseiten



-Mil ucu çektirme deliği DIN 332 sayfa 2 / Tapped center hole to DIN 332, sheet 2 / Zentrierung mit gewinde DIN 332, Blatt 2

## KV773.00

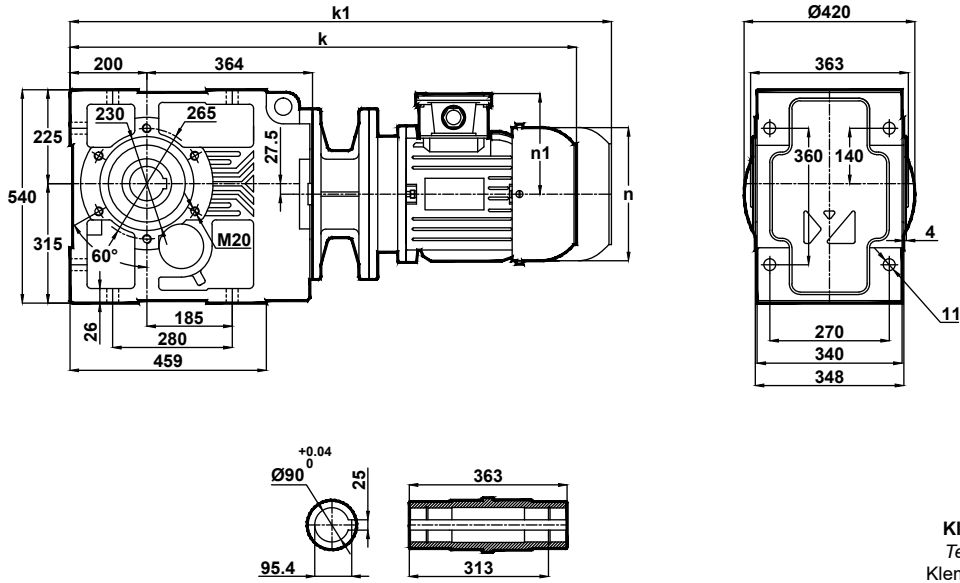

**Klemens Pozisyonları**  
Terminal Box Positions  
Klemmenkasten Positionen

	132S/B5	132M/B5	160M/B5	160L/B5	180M/B5	180L/B5	200L/B5	225S/B5	225M/B5	250M/B5
k	1028	1066	1207	1251	1264	1302	1376	1447	1472	1548
k1	1173	1211	1377	1421	1434	1472	1576	-	-	-
n	258	258	310	310	348	348	390	433	433	480
n1	168	168	225	225	241	241	275	285	285	322

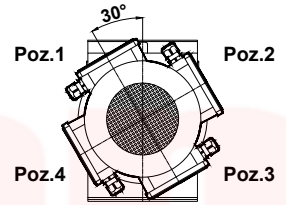

132-160-180-200-225-250  
Tip / Type / Typ

## KV773.01

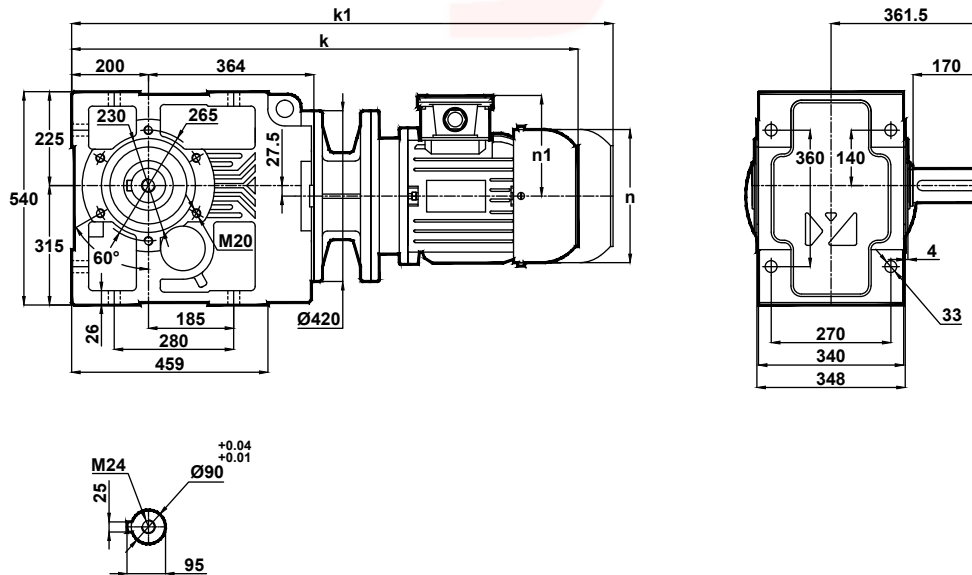

	132S/B5	132M/B5	160M/B5	160L/B5	180M/B5	180L/B5	200L/B5	225S/B5	225M/B5	250M/B5
k	1028	1066	1207	1251	1264	1302	1376	1447	1472	1548
k1	1173	1211	1377	1421	1434	1472	1576	-	-	-
n	258	258	310	310	348	348	390	433	433	480
n1	168	168	225	225	241	241	275	285	285	322





# Ölçü Sayfaları Dimension Pages Abmessungsseiten



-Mil ucu çekirme deliği DIN 332 sayfa 2 / Tapped center hole to DIN 332, sheet 2 / Zentrierung mit gewinde DIN 332, Blatt 2

## KV773.02

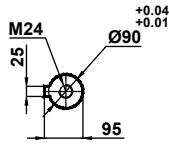
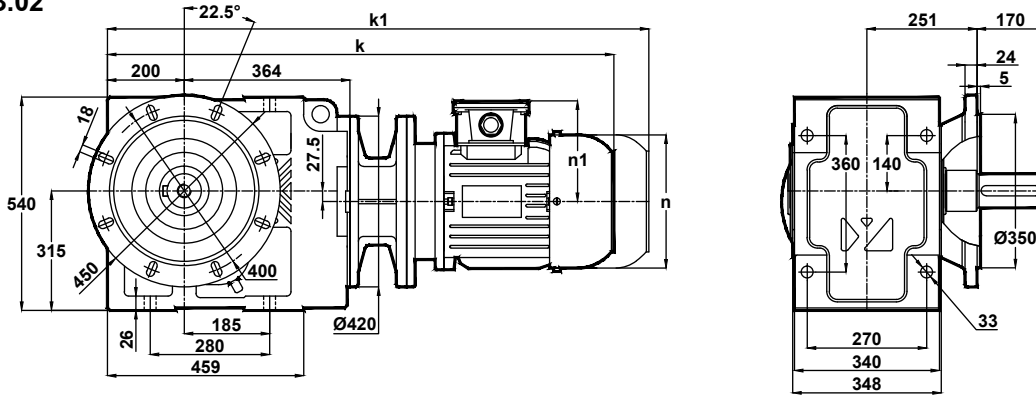

Klemens Pozisyonları  
Terminal Box Positions  
Klemmenkasten Positionen

	132S/B5	132M/B5	160M/B5	160L/B5	180M/B5	180L/B5	200L/B5	225S/B5	225M/B5	250M/B5
k	1028	1066	1207	1251	1264	1302	1376	1447	1472	1548
k1	1173	1211	1377	1421	1434	1472	1576	-	-	-
n	258	258	310	310	348	348	390	433	433	480
n1	168	168	225	225	241	241	275	285	285	322

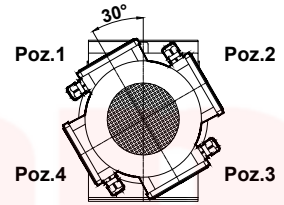

132-160-180-200-225-250  
Tip / Type / Typ

## KV773.03

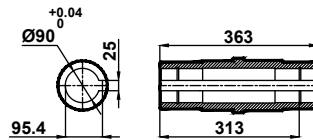
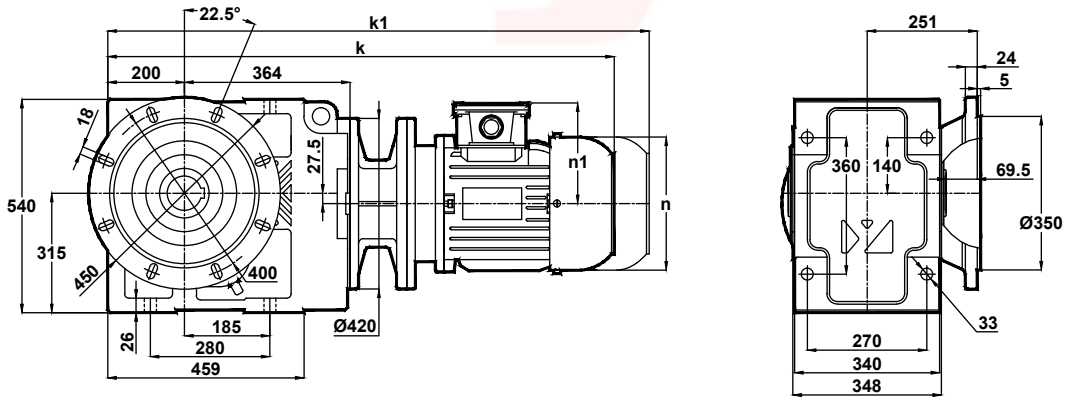

	132S/B5	132M/B5	160M/B5	160L/B5	180M/B5	180L/B5	200L/B5	225S/B5	225M/B5	250M/B5
k	1028	1066	1207	1251	1264	1302	1376	1447	1472	1548
k1	1173	1211	1377	1421	1434	1472	1576	-	-	-
n	258	258	310	310	348	348	390	433	433	480
n1	168	168	225	225	241	241	275	285	285	322



# Ölçü Sayfaları Dimension Pages Abmessungsseiten



-Mil ucu çektirme deliği DIN 332 sayfa 2 / Tapped center hole to DIN 332, sheet 2 / Zentrierung mit gewinde DIN 332, Blatt 2

## KV773.04

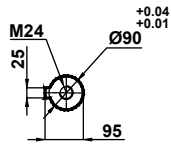
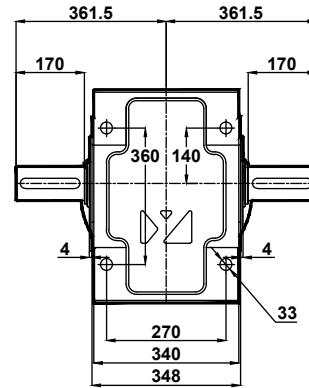
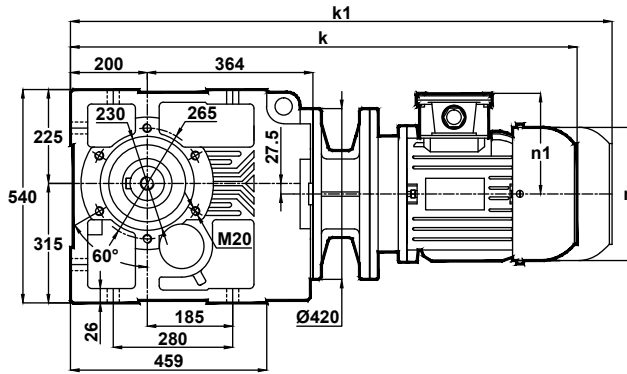

	132S/B5	132M/B5	160M/B5	160L/B5	180M/B5	180L/B5	200L/B5	225S/B5	225M/B5	250M/B5
k	1028	1066	1207	1251	1264	1302	1376	1447	1472	1548
k1	1173	1211	1377	1421	1434	1472	1576	-	-	-
n	258	258	310	310	348	348	390	433	433	480
n1	168	168	225	225	241	241	275	285	285	322

Klemens Pozisyonları  
Terminal Box Positions  
Klemmenkasten Positionen

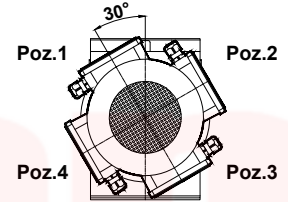

132-160-180-200-225-250  
Tip / Type / Typ

## KV773.05

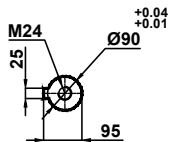
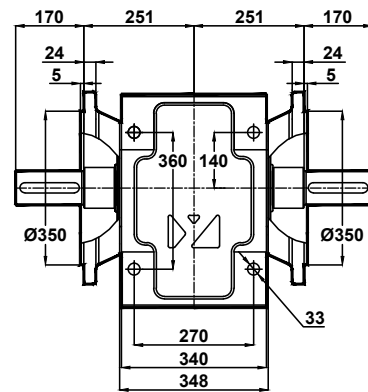
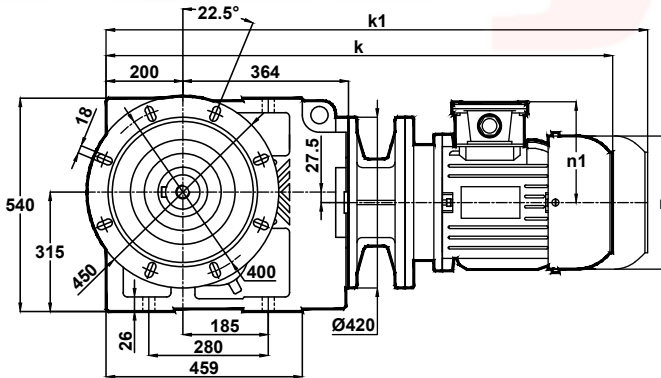

	132S/B5	132M/B5	160M/B5	160L/B5	180M/B5	180L/B5	200L/B5	225S/B5	225M/B5	250M/B5
k	1028	1066	1207	1251	1264	1302	1376	1447	1472	1548
k1	1173	1211	1377	1421	1434	1472	1576	-	-	-
n	258	258	310	310	348	348	390	433	433	480
n1	168	168	225	225	241	241	275	285	285	322



# Ölçü Sayfaları Dimension Pages Abmessungsseiten



-Mil ucu çekirme deliği DIN 332 sayfa 2 / Tapped center hole to DIN 332, sheet 2 / Zentrierung mit gewinde DIN 332, Blatt 2

KV773.08

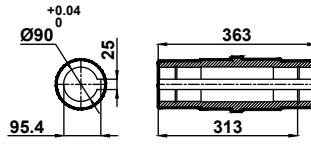
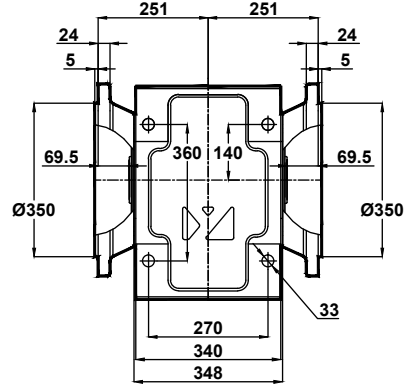
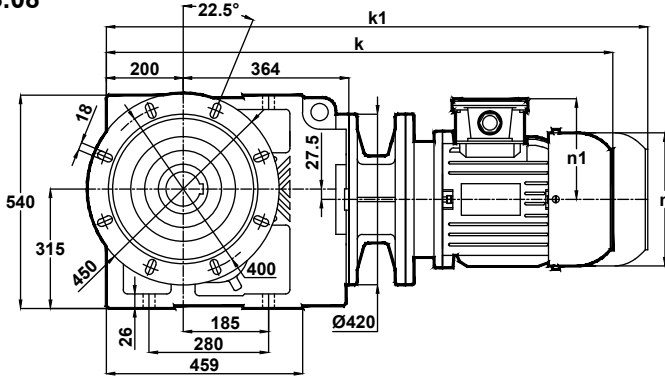

Klemens Pozisyonları  
Terminal Box Positions  
Klemmenkasten Positionen

	132S/B5	132M/B5	160M/B5	160L/B5	180M/B5	180L/B5	200L/B5	225S/B5	225M/B5	250M/B5
k	1028	1066	1207	1251	1264	1302	1376	1447	1472	1548
k1	1173	1211	1377	1421	1434	1472	1576	-	-	-
n	258	258	310	310	348	348	390	433	433	480
n1	168	168	225	225	241	241	275	285	285	322

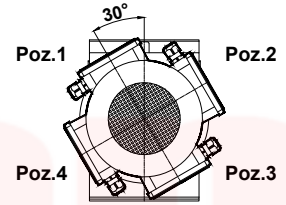

132-160-180-200-225-250  
Tip / Type / Typ



# Ölçü Sayfaları

## Dimension Pages

### Abmessungsseiten



-Mil ucu çekirme deliği DIN 332 sayfa 2 / Tapped center hole to DIN 332, sheet 2 / Zentrierung mit gewinde DIN 332, Blatt 2

#### KV774.00

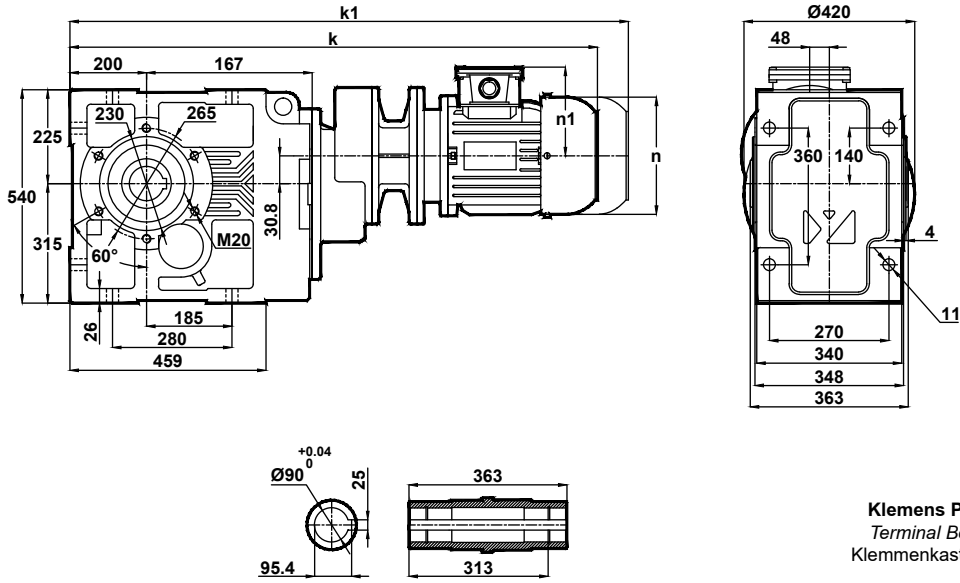

**Klemens Pozisyonları**  
Terminal Box Positions  
Klemmenkasten Positionen

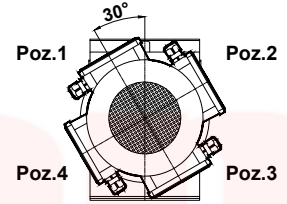

90-100-112-132-160-180  
Tip / Type / Typ

	90S/B5	90L/B5	100L/B5	112M/B5	132S/B5	132M/B5	160M/B5	160L/B5	180M/B5	180L/B5
k	982	1007	1057	1077	1140	1178	1329	1373	1386	1424
k1	1107	1132	1192	1212	1285	1323	1499	1543	1556	1594
n	176	176	194	218	258	258	310	310	348	348
n1	126	126	135	146	168	168	225	225	241	241

#### KV774.01

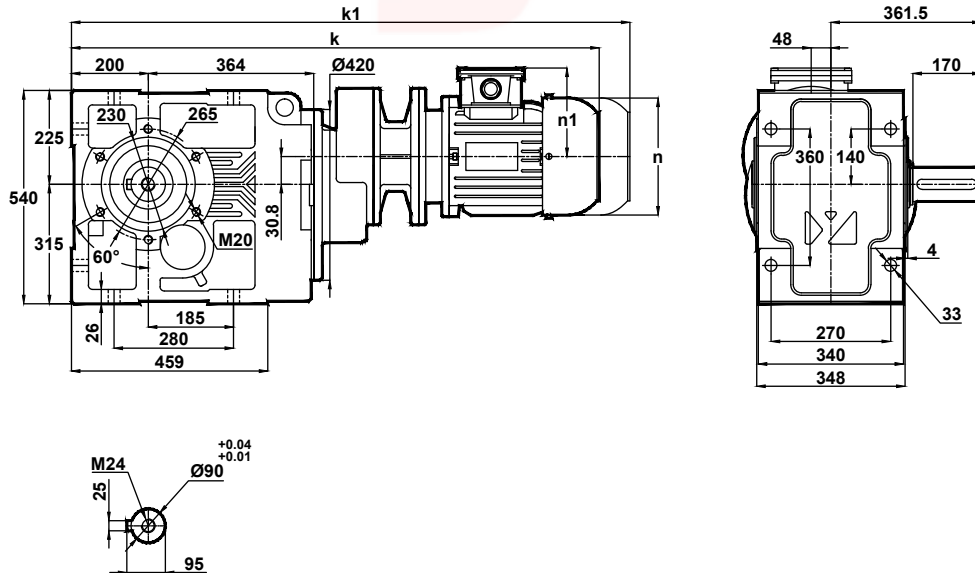

	90S/B5	90L/B5	100L/B5	112M/B5	132S/B5	132M/B5	160M/B5	160L/B5	180M/B5	180L/B5
k	982	1007	1057	1077	1140	1178	1329	1373	1386	1424
k1	1107	1132	1192	1212	1285	1323	1499	1543	1556	1594
n	176	176	194	218	258	258	310	310	348	348
n1	126	126	135	146	168	168	225	225	241	241



# Ölçü Sayfaları Dimension Pages Abmessungsseiten



-Mil ucu çekirme deliği DIN 332 sayfa 2 / Tapped center hole to DIN 332, sheet 2 / Zentrierung mit gewinde DIN 332, Blatt 2

## KV774.02

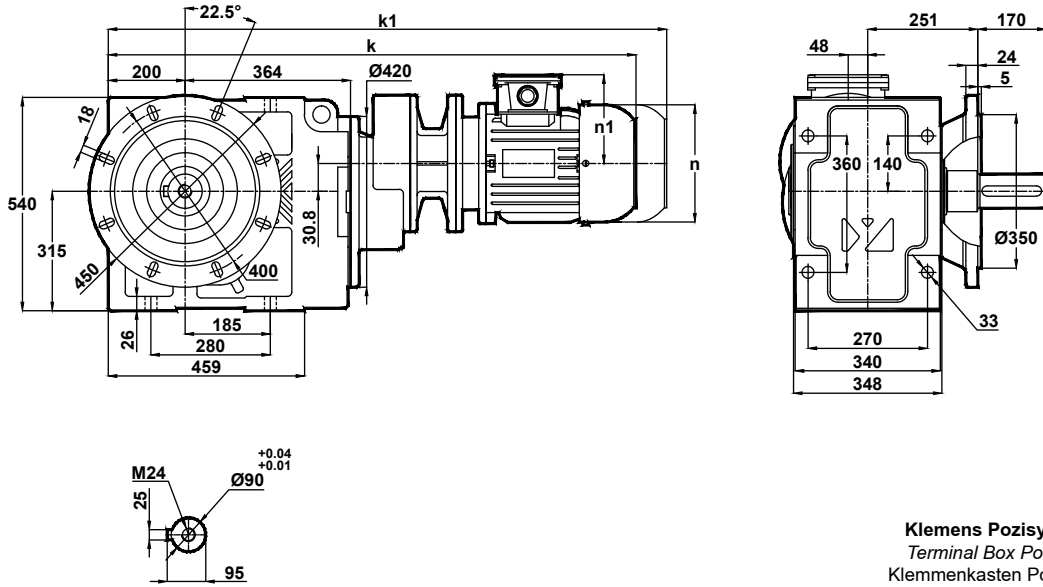

Klemens Pozisyonları  
Terminal Box Positions  
Klemmenkasten Positionen

	90S/B5	90L/B5	100L/B5	112M/B5	132S/B5	132M/B5	160M/B5	160L/B5	180M/B5	180L/B5
k	982	1007	1057	1077	1140	1178	1329	1373	1386	1424
k1	1107	1132	1192	1212	1285	1323	1499	1543	1556	1594
n	176	176	194	218	258	258	310	310	348	348
n1	126	126	135	146	168	168	225	225	241	241

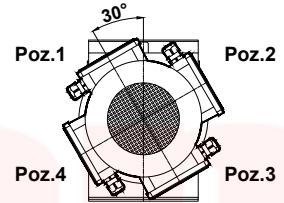

90-100-112-132-160-180  
Tip / Type / Typ

## KV774.03

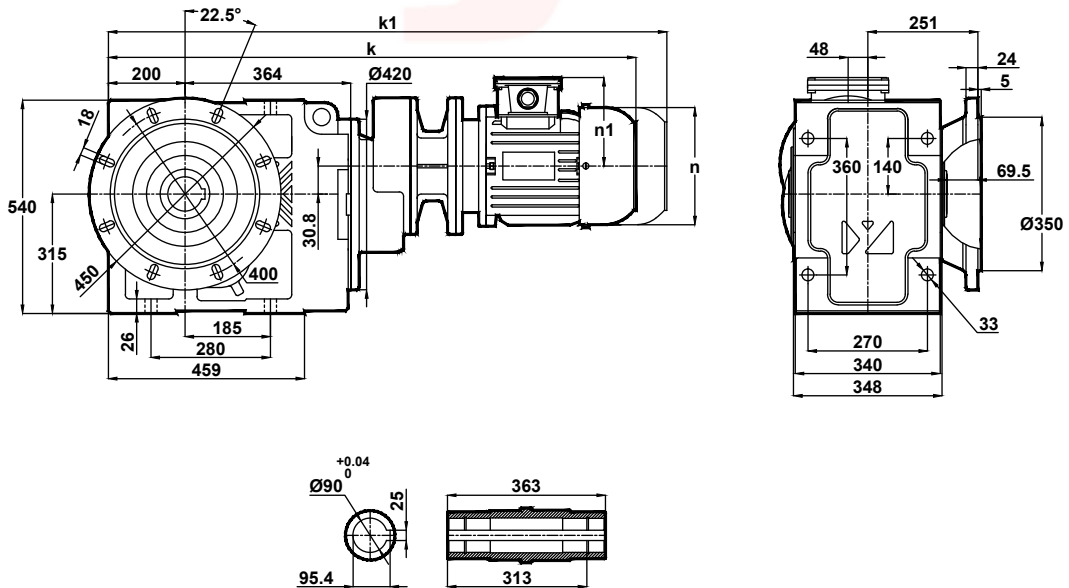

	90S/B5	90L/B5	100L/B5	112M/B5	132S/B5	132M/B5	160M/B5	160L/B5	180M/B5	180L/B5
k	982	1007	1057	1077	1140	1178	1329	1373	1386	1424
k1	1107	1132	1192	1212	1285	1323	1499	1543	1556	1594
n	176	176	194	218	258	258	310	310	348	348
n1	126	126	135	146	168	168	225	225	241	241



# Ölçü Sayfaları

## Dimension Pages

### Abmessungsseiten



-Mil ucu çekirme deliği DIN 332 sayfa 2 / Tapped center hole to DIN 332, sheet 2 / Zentrierung mit gewinde DIN 332, Blatt 2

#### KV774.04

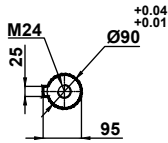
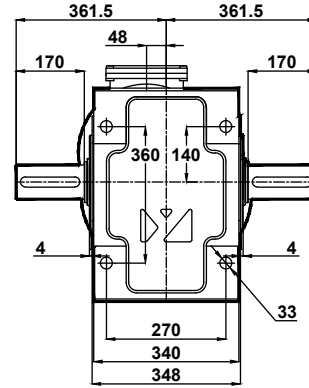
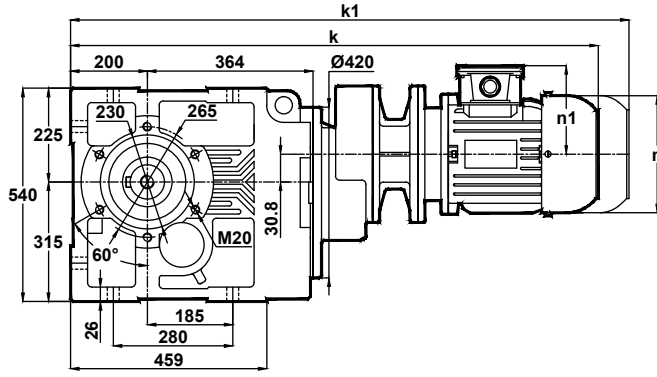

	90S/B5	90L/B5	100L/B5	112M/B5	132S/B5	132M/B5	160M/B5	160L/B5	180M/B5	180L/B5
k	982	1007	1057	1077	1140	1178	1329	1373	1386	1424
k1	1107	1132	1192	1212	1285	1323	1499	1543	1556	1594
n	176	176	194	218	258	258	310	310	348	348
n1	126	126	135	146	168	168	225	225	241	241

**Klemens Pozisyonları**  
Terminal Box Positions  
Klemmenkasten Positionen

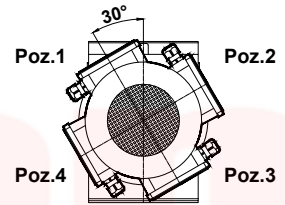

90-100-112-132-160-180  
T10 / T10e / T10v

#### KV774.05

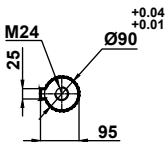
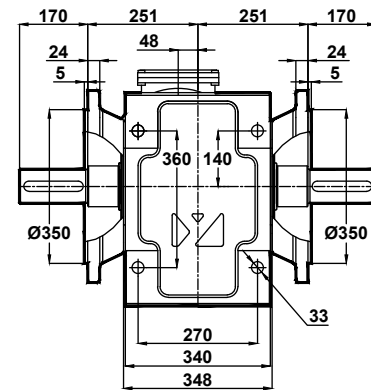
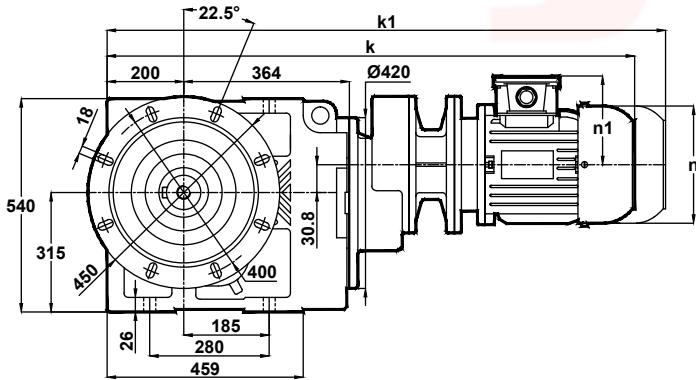

	90S/B5	90L/B5	100L/B5	112M/B5	132S/B5	132M/B5	160M/B5	160L/B5	180M/B5	180L/B5
k	982	1007	1057	1077	1140	1178	1329	1373	1386	1424
k1	1107	1132	1192	1212	1285	1323	1499	1543	1556	1594
n	176	176	194	218	258	258	310	310	348	348
n1	126	126	135	146	168	168	225	225	241	241



# Ölçü Sayfaları Dimension Pages Abmessungsseiten



-Mil ucu çekirme deliği DIN 332 sayfa 2 / Tapped center hole to DIN 332, sheet 2 / Zentrierung mit gewinde DIN 332, Blatt 2

KV774.08

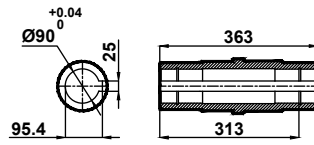
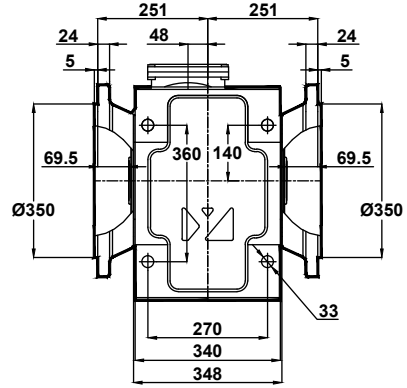
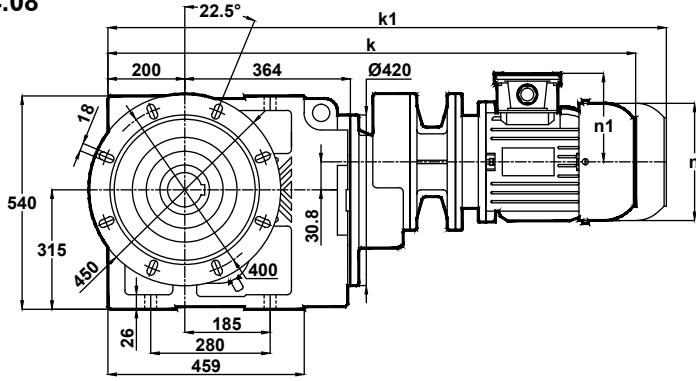

**Klemens Pozisyonları**  
Terminal Box Positions  
Klemmenkasten Positionen

	90S/B5	90L/B5	100L/B5	112M/B5	132S/B5	132M/B5	160M/B5	160L/B5	180M/B5	180L/B5
k	982	1007	1057	1077	1140	1178	1329	1373	1386	1424
k1	1107	1132	1192	1212	1285	1323	1499	1543	1556	1594
n	176	176	194	218	258	258	310	310	348	348
n1	126	126	135	146	168	168	225	225	241	241

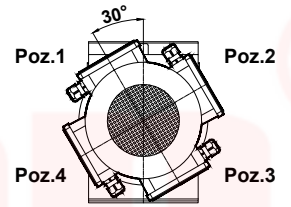

90-100-112-132-160-180  
Tip / Type / Typ



# Ölçü Sayfaları Dimension Pages Abmessungsseiten



-Mil ucu çektirme deliği DIN 332 sayfa 2 / Tapped center hole to DIN 332, sheet 2 / Zentrierung mit gewinde DIN 332, Blatt 2

KV775.00  
KV776.00

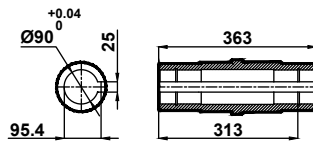
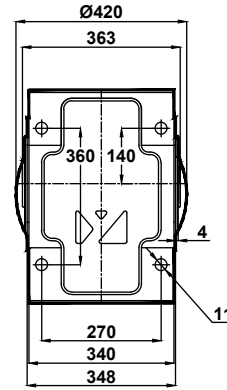
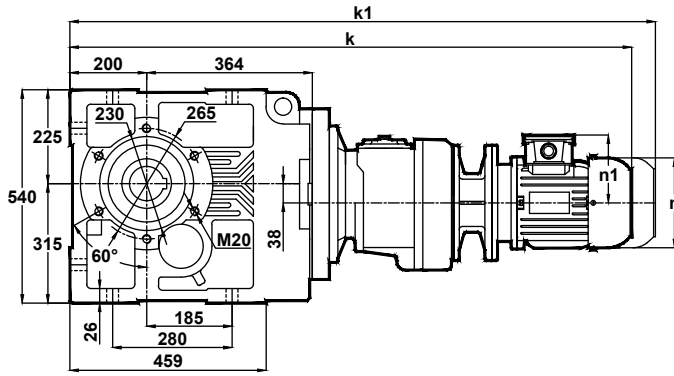

Klemens Pozisyonları  
Terminal Box Positions  
Klemmenkasten Positionen

	71/B5	80/B5	90S/B5	90L/B5	100L/B5	112M/B5	132S/B5	132M/B5
k	1093	1113	1133	1158	1207	1227	1291	1329
k1	1213	1233	1258	1283	1342	1362	1436	1474
n	138	156	176	176	194	218	258	258
n1	110	118	126	126	135	146	168	168

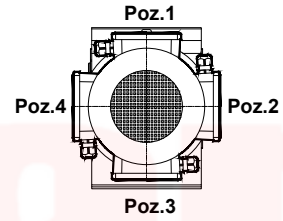

71-80-90-100-112-132  
Tip / Type / Typ

KV775.01  
KV776.01

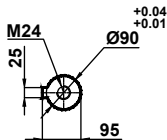
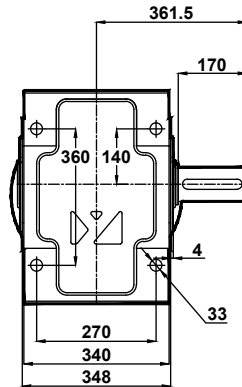
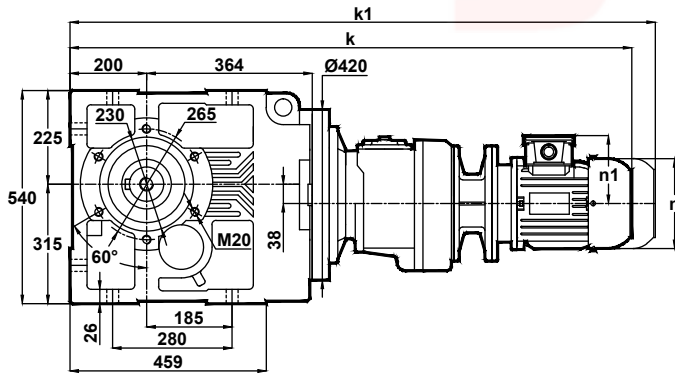

	71/B5	80/B5	90S/B5	90L/B5	100L/B5	112M/B5	132S/B5	132M/B5
k	1093	1113	1133	1158	1207	1227	1291	1329
k1	1213	1233	1258	1283	1342	1362	1436	1474
n	138	156	176	176	194	218	258	258
n1	110	118	126	126	135	146	168	168





# Ölçü Sayfaları Dimension Pages Abmessungsseiten



-Mil ucu çekirme deliği DIN 332 sayfa 2 / Tapped center hole to DIN 332, sheet 2 / Zentrierung mit gewinde DIN 332, Blatt 2

KV775.02  
KV776.02

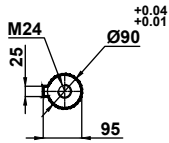
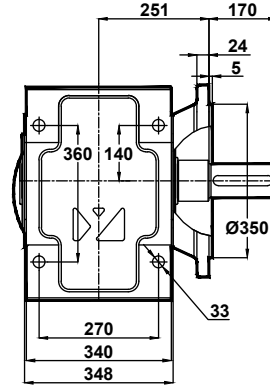
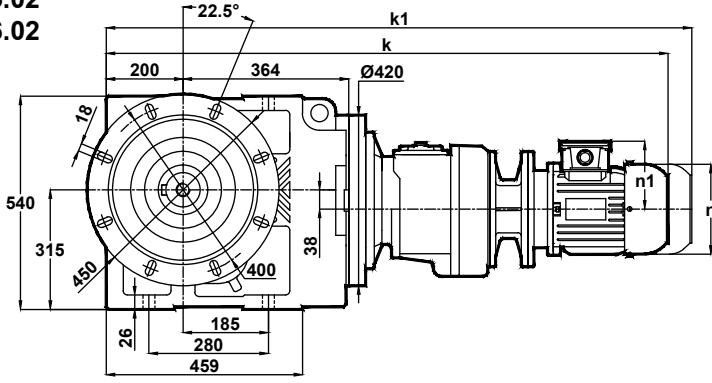

Klemens Pozisyonları  
Terminal Box Positions  
Klemmenkasten Positionen

	71/B5	80/B5	90S/B5	90L/B5	100L/B5	112M/B5	132S/B5	132M/B5
k	1093	1113	1133	1158	1207	1227	1291	1329
k1	1213	1233	1258	1283	1342	1362	1436	1474
n	138	156	176	176	194	218	258	258
n1	110	118	126	126	135	146	168	168

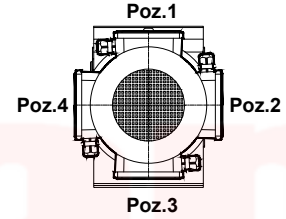

71-80-90-100-112-132  
Tip / Type / Typ

KV775.03  
KV776.03

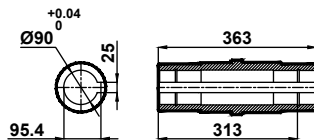
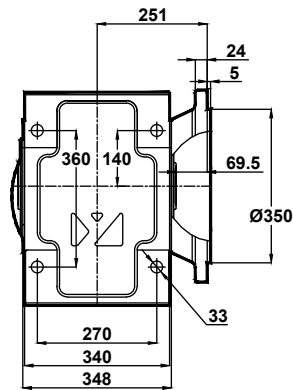
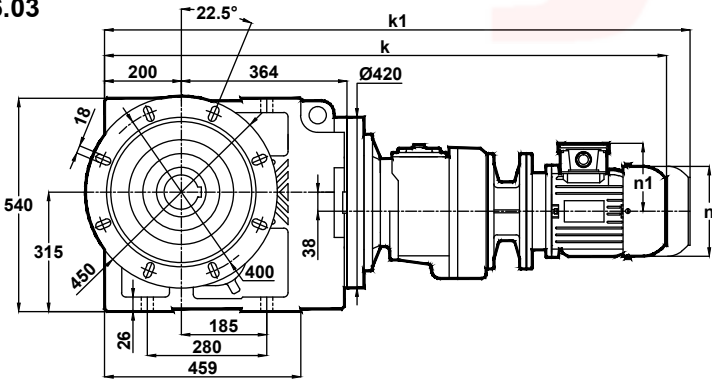

	71/B5	80/B5	90S/B5	90L/B5	100L/B5	112M/B5	132S/B5	132M/B5
k	1093	1113	1133	1158	1207	1227	1291	1329
k1	1213	1233	1258	1283	1342	1362	1436	1474
n	138	156	176	176	194	218	258	258
n1	110	118	126	126	135	146	168	168



# Ölçü Sayfaları Dimension Pages Abmessungsseiten



-Mil ucu çektirme deliği DIN 332 sayfa 2 / Tapped center hole to DIN 332, sheet 2 / Zentrierung mit gewinde DIN 332, Blatt 2

KV775.04  
KV776.04

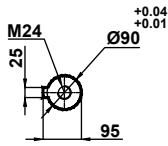
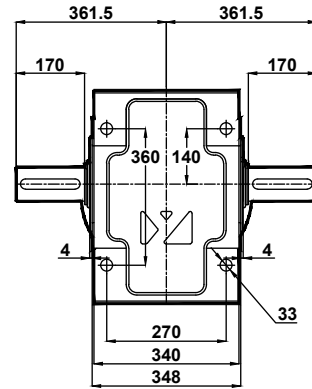
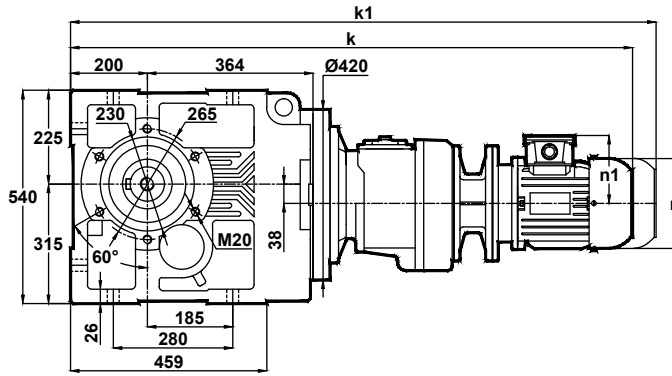

	71/B5	80/B5	90S/B5	90L/B5	100L/B5	112M/B5	132S/B5	132M/B5
k	1093	1113	1133	1158	1207	1227	1291	1329
k1	1213	1233	1258	1283	1342	1362	1436	1474
n	138	156	176	176	194	218	258	258
n1	110	118	126	126	135	146	168	168

Klemens Pozisyonları  
Terminal Box Positions  
Klemmenkasten Positionen

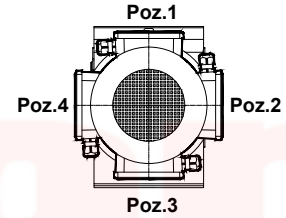

71-80-90-100-112-132  
Tip / Type / Typ

KV775.05  
KV776.05

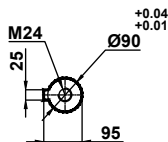
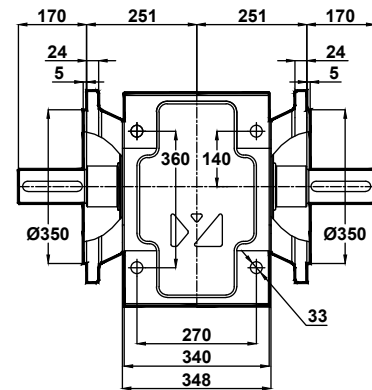
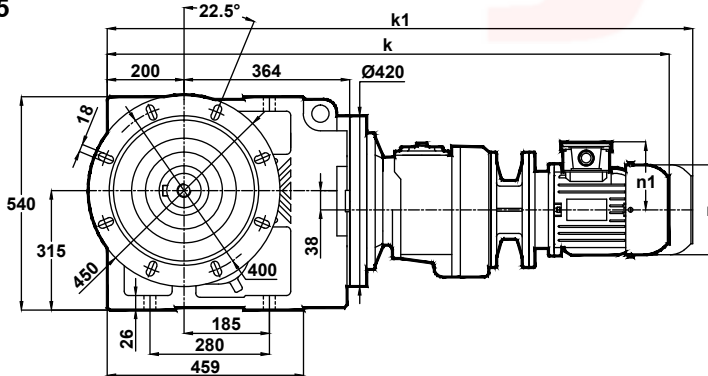

	71/B5	80/B5	90S/B5	90L/B5	100L/B5	112M/B5	132S/B5	132M/B5
k	1093	1113	1133	1158	1207	1227	1291	1329
k1	1213	1233	1258	1283	1342	1362	1436	1474
n	138	156	176	176	194	218	258	258
n1	110	118	126	126	135	146	168	168



# Ölçü Sayfaları Dimension Pages Abmessungenseiten



-Mil ucu çektirme deliği DIN 332 sayfa 2 / Tapped center hole to DIN 332, sheet 2 / Zentrierung mit gewinde DIN 332, Blatt 2

KV775.08  
KV776.08

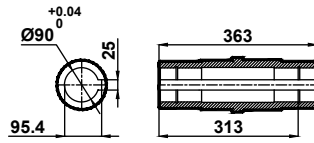
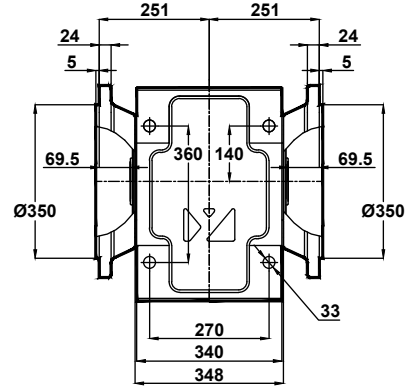
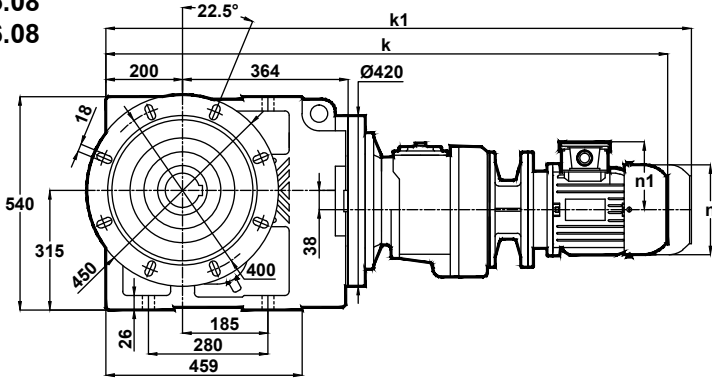

Klemens Pozisyonları  
Terminal Box Positions  
Klemmenkasten Positionen

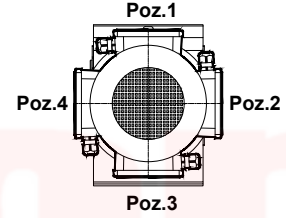

71-80-90-100-112-132  
Tip / Type / Typ

	71/B5	80/B5	90S/B5	90L/B5	100L/B5	112M/B5	132S/B5	132M/B5
k	1093	1113	1133	1158	1207	1227	1291	1329
k1	1213	1233	1258	1283	1342	1362	1436	1474
n	138	156	176	176	194	218	258	258
n1	110	118	126	126	135	146	168	168



# Ölçü Sayfaları Dimension Pages Abmessungsseiten



-Mil ucu çektirme deliği DIN 332 sayfa 2 / Tapped center hole to DIN 332, sheet 2 / Zentrierung mit gewinde DIN 332, Blatt 2

## KV873.00

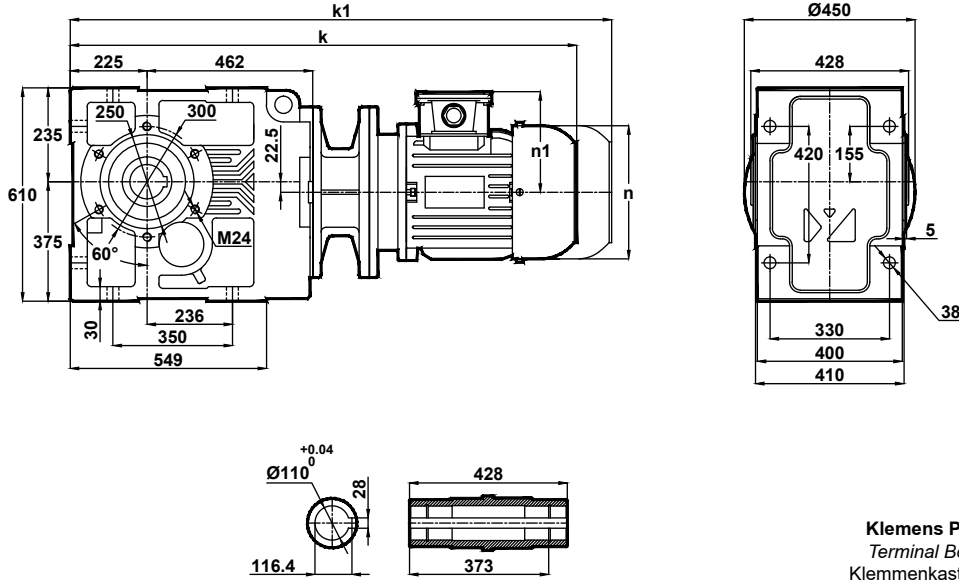

	160M/B5	160L/B5	180M/B5	180L/B5	200L/B5	225S/B5	225M/B5	250M/B5	280S/B5	280M/B5
k	1395	1439	1452	1490	1542	1560	1585	1661	1723	1723
k1	1595	1609	1622	1660	1742	-	-	-	-	-
n	310	310	348	348	390	433	433	480	544	544
n1	225	225	241	241	275	285	285	322	350	350

Klemens Pozisyonları  
Terminal Box Positions  
Klemmenkasten Positionen

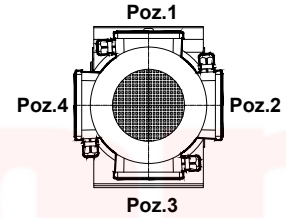

160-180-200-225-250-280  
Tip / Type / Typ

## KV873.01

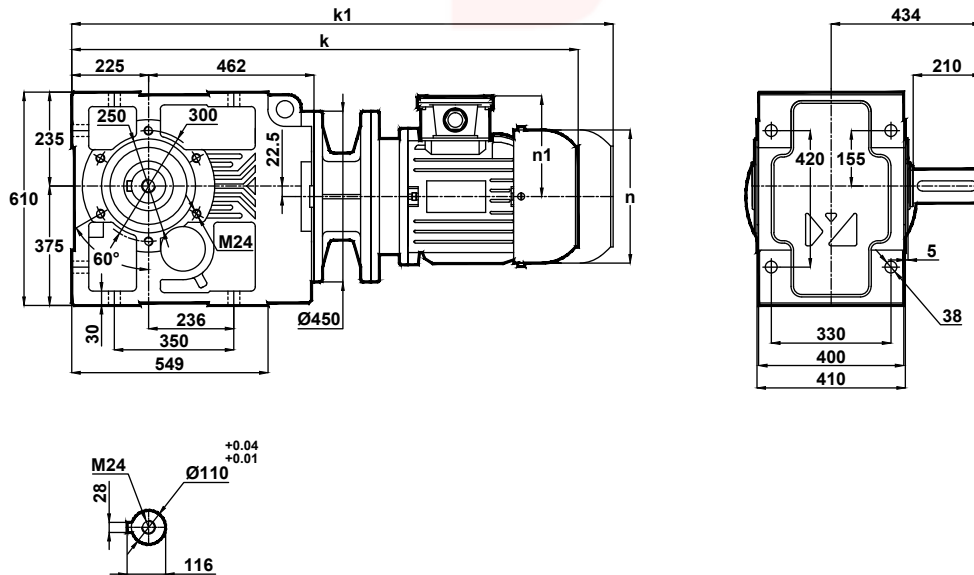

	160M/B5	160L/B5	180M/B5	180L/B5	200L/B5	225S/B5	225M/B5	250M/B5	280S/B5	280M/B5
k	1395	1439	1452	1490	1542	1560	1585	1661	1723	1723
k1	1595	1609	1622	1660	1742	-	-	-	-	-
n	310	310	348	348	390	433	433	480	544	544
n1	225	225	241	241	275	285	285	322	350	350



# Ölçü Sayfaları Dimension Pages Abmessungsseiten



-Mil ucu çektirme deliği DIN 332 sayfa 2 / Tapped center hole to DIN 332, sheet 2 / Zentrierung mit gewinde DIN 332, Blatt 2

## KV873.02

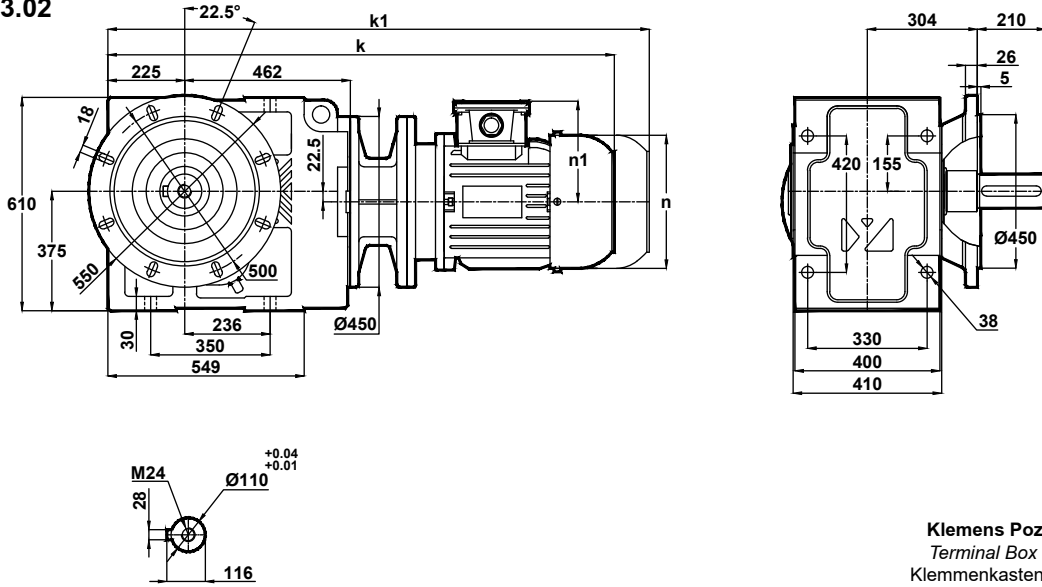

Klemens Pozisyonları  
Terminal Box Positions  
Klemmenkasten Positionen

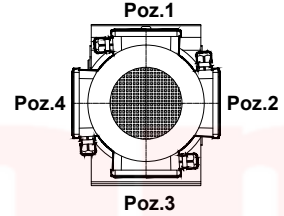

160-180-200-225-250-280  
Tip / Type / Typ

	160M/B5	160L/B5	180M/B5	180L/B5	200L/B5	225S/B5	225M/B5	250M/B5	280S/B5	280M/B5
k	1395	1439	1452	1490	1542	1560	1585	1661	1723	1723
k1	1595	1609	1622	1660	1742	-	-	-	-	-
n	310	310	348	348	390	433	433	480	544	544
n1	225	225	241	241	275	285	285	322	350	350

## KV873.03

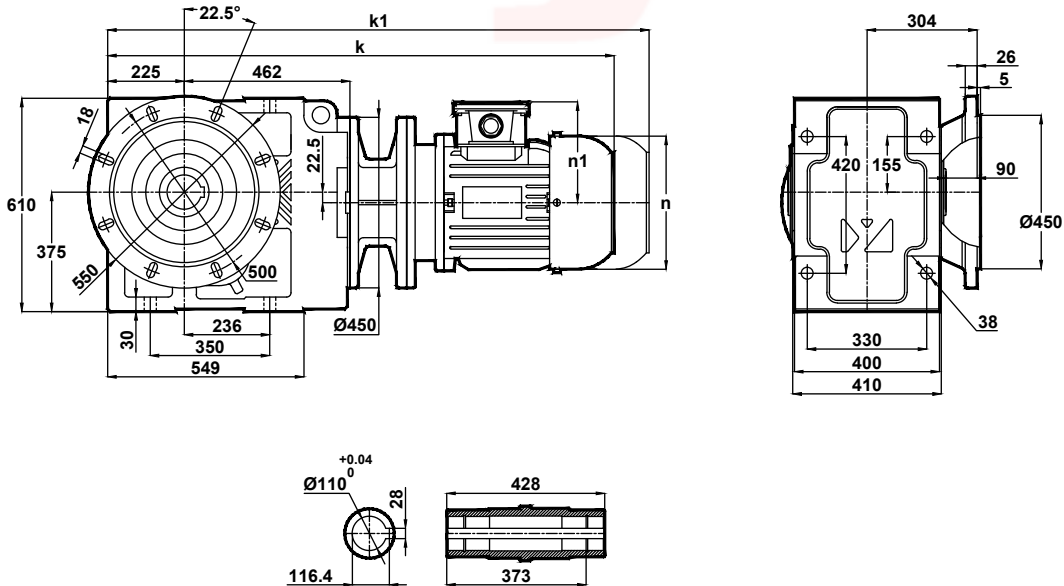

	160M/B5	160L/B5	180M/B5	180L/B5	200L/B5	225S/B5	225M/B5	250M/B5	280S/B5	280M/B5
k	1395	1439	1452	1490	1542	1560	1585	1661	1723	1723
k1	1595	1609	1622	1660	1742	-	-	-	-	-
n	310	310	348	348	390	433	433	480	544	544
n1	225	225	241	241	275	285	285	322	350	350



# Ölçü Sayfaları Dimension Pages Abmessungsseiten



-Mil ucu çekirme deliği DIN 332 sayfa 2 / Tapped center hole to DIN 332, sheet 2 / Zentrierung mit gewinde DIN 332, Blatt 2

## KV873.04

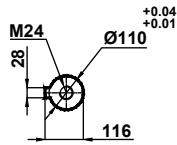
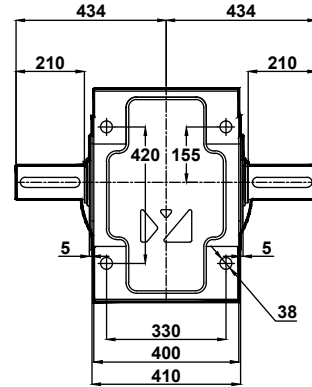
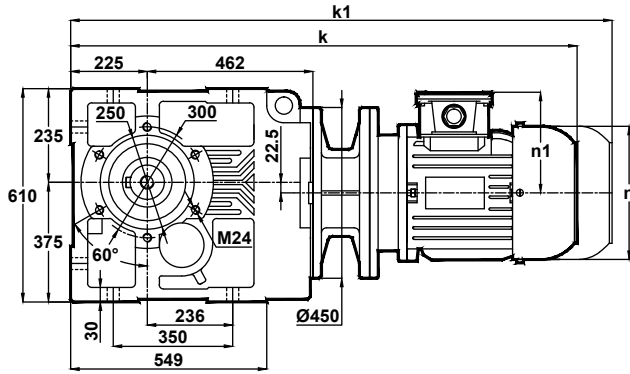

Klemens Pozisyonları  
Terminal Box Positions  
Klemmenkasten Positionen

	160M/B5	160L/B5	180M/B5	180L/B5	200L/B5	225S/B5	225M/B5	250M/B5	280S/B5	280M/B5
k	1395	1439	1452	1490	1542	1560	1585	1661	1723	1723
k1	1565	1609	1622	1660	1742	-	-	-	-	-
n	310	310	348	348	390	433	433	480	544	544
n1	225	225	241	241	275	285	285	322	350	350

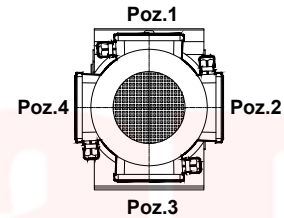

160-180-200-225-250-280  
Tip / Type / Typ

## KV873.05

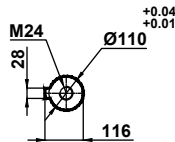
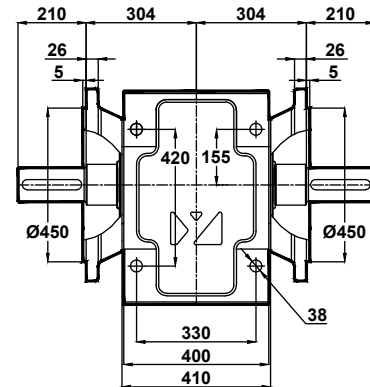
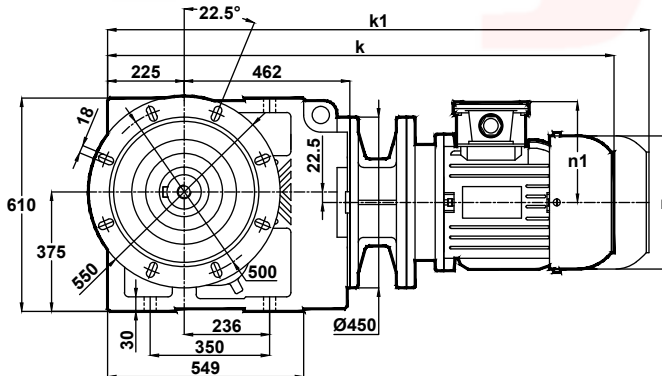

	160M/B5	160L/B5	180M/B5	180L/B5	200L/B5	225S/B5	225M/B5	250M/B5	280S/B5	280M/B5
k	1395	1439	1452	1490	1542	1560	1585	1661	1723	1723
k1	1595	1609	1622	1660	1742	-	-	-	-	-
n	310	310	348	348	390	433	433	480	544	544
n1	225	225	241	241	275	285	285	322	350	350



# Ölçü Sayfaları Dimension Pages Abmessungenseiten



-Mil ucu çekirme deliği DIN 332 sayfa 2 / Tapped center hole to DIN 332, sheet 2 / Zentrierung mit gewinde DIN 332, Blatt 2

KV873.08

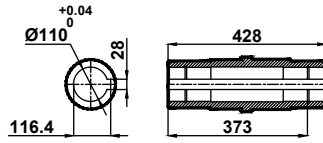
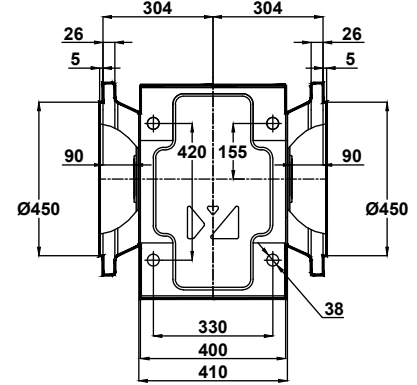
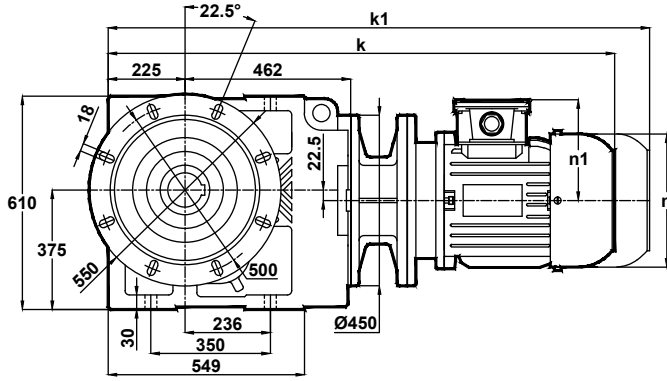

Klemens Pozisyonları  
Terminal Box Positions  
Klemmenkasten Positionen

	160M/B5	160L/B5	180M/B5	180L/B5	200L/B5	225S/B5	225M/B5	250M/B5	280S/B5	280M/B5
k	1395	1439	1452	1490	1542	1560	1585	1661	1723	1723
k1	1595	1609	1622	1660	1742	-	-	-	-	-
n	310	310	348	348	390	433	433	480	544	544
n1	225	225	241	241	275	285	285	322	350	350

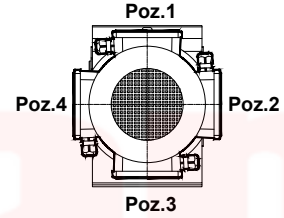

160-180-200-225-250-280  
Tip / Type / Typ



# Ölçü Sayfaları Dimension Pages Abmessungenseiten



-Mil ucu çektirme deliği DIN 332 sayfa 2 / Tapped center hole to DIN 332, sheet 2 / Zentrierung mit gewinde DIN 332, Blatt 2

## KV874.00

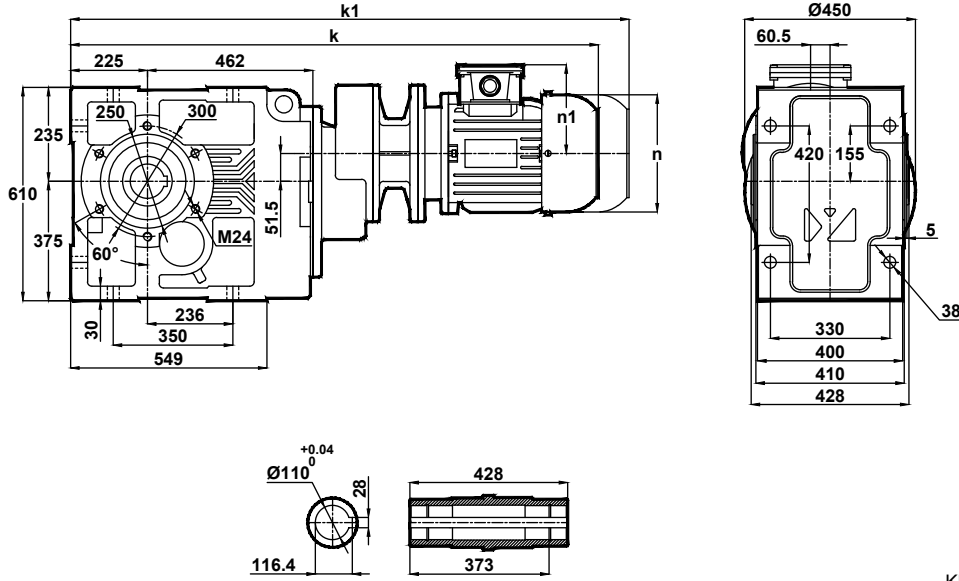

	100L/B5	112M/B5	132S/B5	132M/B5	160M/B5	160L/B5	180M/B5	180L/B5	200L/B5
k	1194	1214	1279	1317	1464	1508	1521	1559	1631
k1	1329	1349	1424	1462	1634	1678	1691	1729	1831
n	194	218	258	258	310	310	348	348	390
n1	135	146	168	168	225	225	241	241	275

Klemens Pozisyonları  
Terminal Box Positions  
Klemmenkasten Positionen

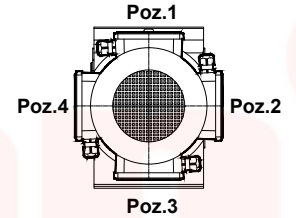

100-112-132-160-180-200  
Tip / Type / Typ

## KV874.01

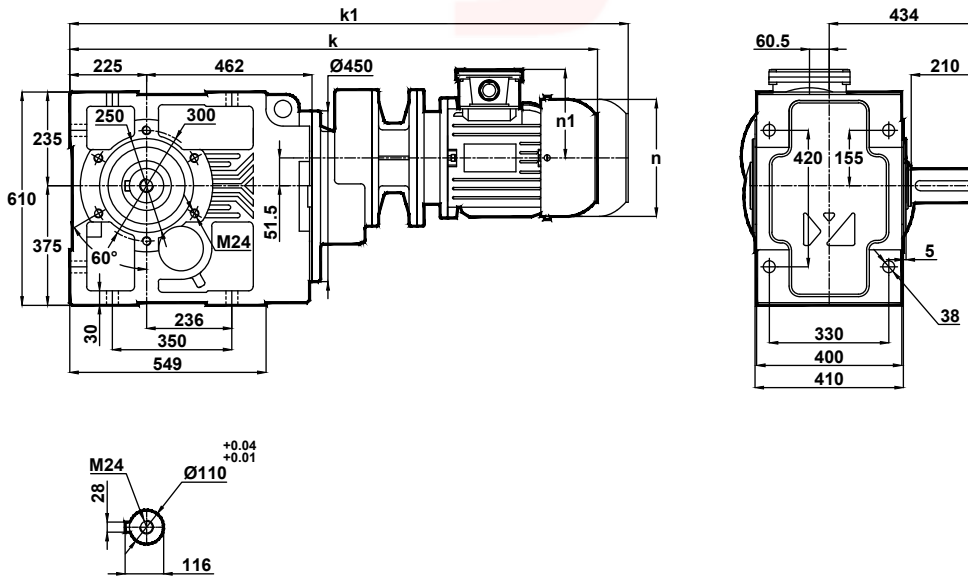

	100L/B5	112M/B5	132S/B5	132M/B5	160M/B5	160L/B5	180M/B5	180L/B5	200L/B5
k	1194	1214	1279	1317	1464	1508	1521	1559	1631
k1	1329	1349	1424	1462	1634	1678	1691	1729	1831
n	194	218	258	258	310	310	348	348	390
n1	135	146	168	168	225	225	241	241	275





# Ölçü Sayfaları Dimension Pages Abmessungsseiten



-Mil ucu çekirme deliği DIN 332 sayfa 2 / Tapped center hole to DIN 332, sheet 2 / Zentrierung mit gewinde DIN 332, Blatt 2

## KV874.02

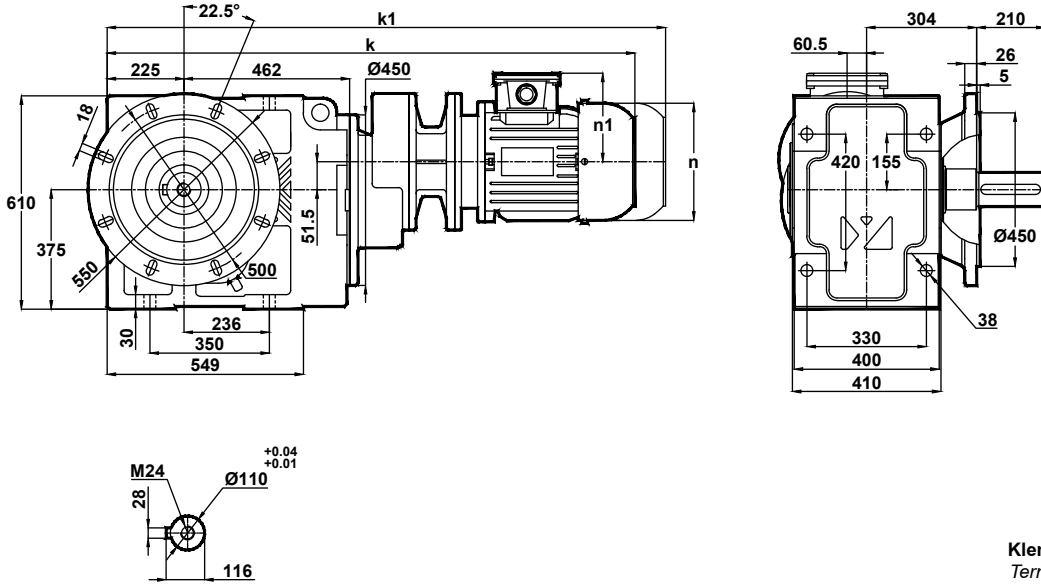

	100L/B5	112M/B5	132S/B5	132M/B5	160M/B5	160L/B5	180M/B5	180L/B5	200L/B5
k	1194	1214	1279	1317	1464	1508	1521	1559	1631
k1	1329	1349	1424	1462	1634	1678	1691	1729	1831
n	194	218	258	258	310	310	348	348	390
n1	135	146	168	168	225	225	241	241	275

Klemens Pozisyonları  
Terminal Box Positions  
Klemmenkasten Positionen

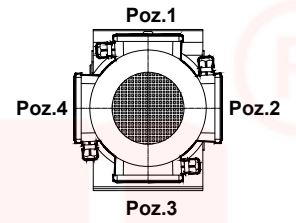

100-112-132-160-180-200  
Tip / Type / Typ

## KV874.03

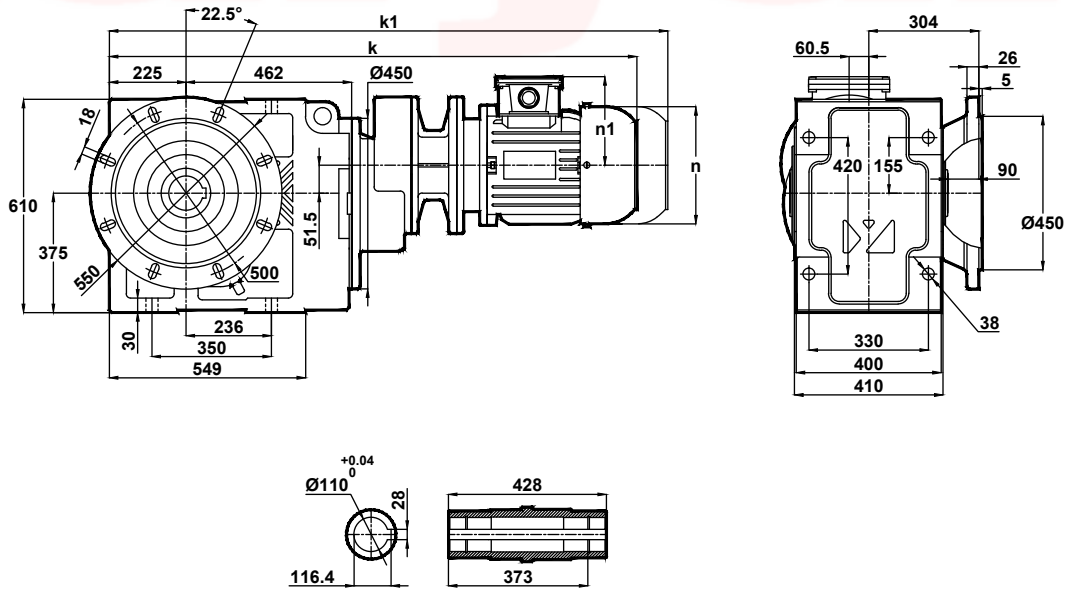

	100L/B5	112M/B5	132S/B5	132M/B5	160M/B5	160L/B5	180M/B5	180L/B5	200L/B5
k	1194	1214	1279	1317	1464	1508	1521	1559	1631
k1	1329	1349	1424	1462	1634	1678	1691	1729	1831
n	194	218	258	258	310	310	348	348	390
n1	135	146	168	168	225	225	241	241	275



# Ölçü Sayfaları

## Dimension Pages

### Abmessungenseiten



-Mil ucu çektirme deliği DIN 332 sayfa 2 / Tapped center hole to DIN 332, sheet 2 / Zentrierung mit gewinde DIN 332, Blatt 2

#### KV874.04

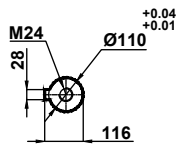
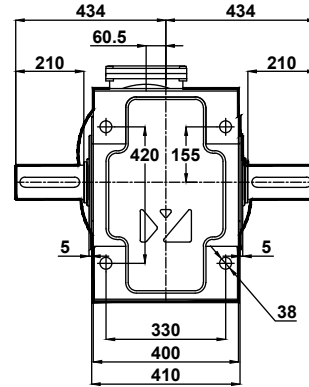
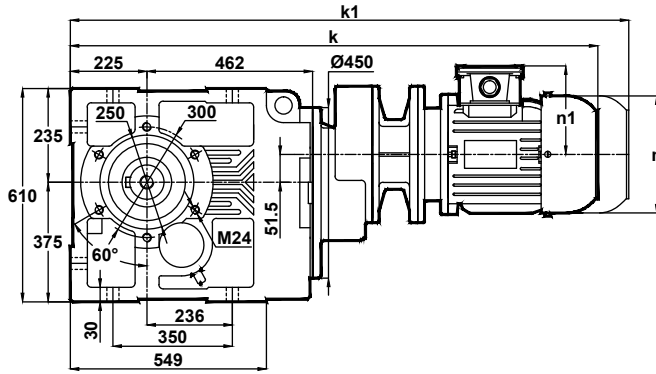

	100L/B5	112M/B5	132S/B5	132M/B5	160M/B5	160L/B5	180M/B5	180L/B5	200L/B5
k	1194	1214	1279	1317	1464	1508	1521	1559	1631
k1	1329	1349	1424	1462	1634	1678	1691	1729	1831
n	194	218	258	258	310	310	348	348	390
n1	135	146	168	168	225	225	241	241	275

Klemens Pozisyonları  
Terminal Box Positions  
Klemmenkasten Positionen

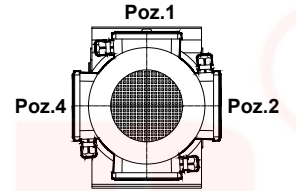

Poz.3  
100-112-132-160-180-200  
Tip / Type / Typ

#### KV874.05

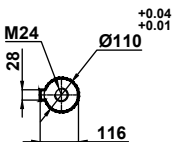
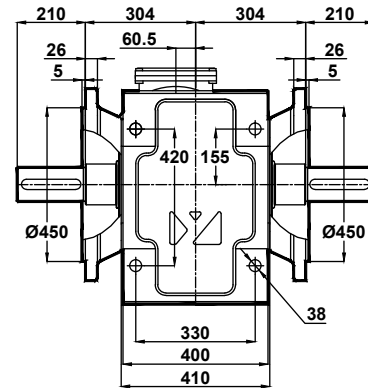
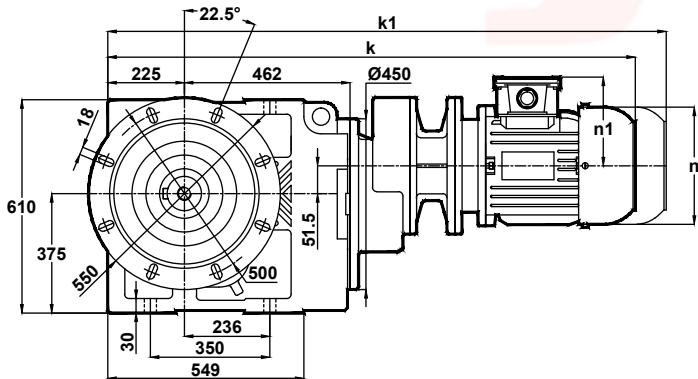

	100L/B5	112M/B5	132S/B5	132M/B5	160M/B5	160L/B5	180M/B5	180L/B5	200L/B5
k	1194	1214	1279	1317	1464	1508	1521	1559	1631
k1	1329	1349	1424	1462	1634	1678	1691	1729	1831
n	194	218	258	258	310	310	348	348	390
n1	135	146	168	168	225	225	241	241	275



# Ölçü Sayfaları Dimension Pages Abmessungsseiten



-Mil ucu çekirme deliği DIN 332 sayfa 2 / Tapped center hole to DIN 332, sheet 2 / Zentrierung mit gewinde DIN 332, Blatt 2

KV874.08

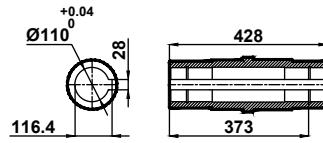
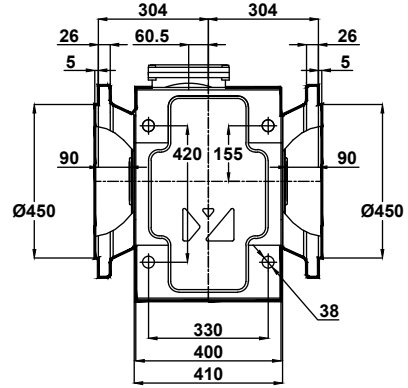
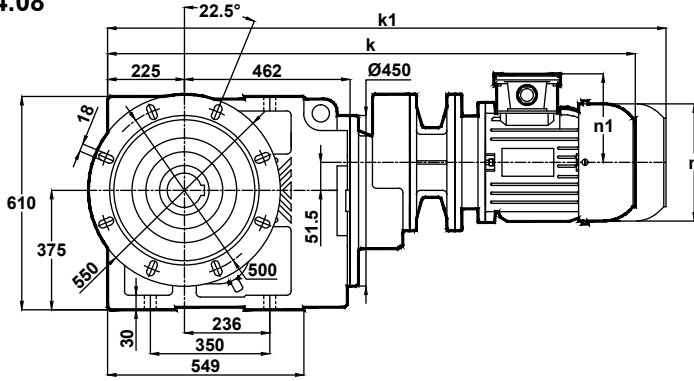

Klemens Pozisyonları  
Terminal Box Positions  
Klemmenkasten Positionen

	100L/B5	112M/B5	132S/B5	132M/B5	160M/B5	160L/B5	180M/B5	180L/B5	200L/B5
k	1194	1214	1279	1317	1464	1508	1521	1559	1631
k1	1329	1349	1424	1462	1634	1678	1691	1729	1831
n	194	218	258	258	310	310	348	348	390
n1	135	146	168	168	225	225	241	241	275

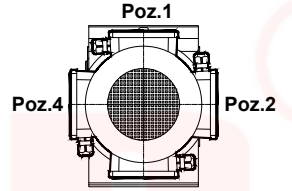

Poz.3  
100-112-132-160-180-200  
Tip / Type / Typ



# Ölçü Sayfaları Dimension Pages Abmessungenseiten



-Mil ucu çekirme deliği DIN 332 sayfa 2 / Tapped center hole to DIN 332, sheet 2 / Zentrierung mit gewinde DIN 332, Blatt 2

KV875.00  
KV876.00

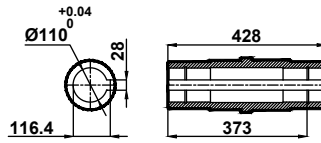
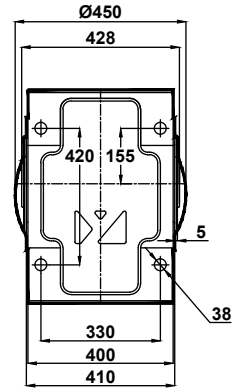
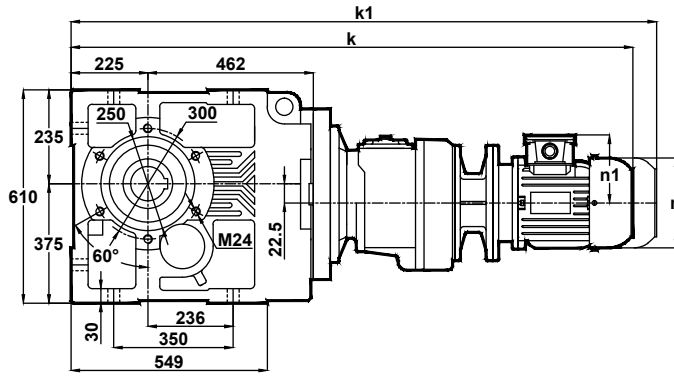

Klemens Pozisyonları  
Terminal Box Positions  
Klemmenkasten Positionen

	71/B5	80/B5	90S/B5	90L/B5	100L/B5	112M/B5	132S/B5	132M/B5
k	1216	1236	1256	1281	1330	1350	1414	1452
k1	1336	1356	1381	1406	1465	1485	1559	1597
n	138	156	176	176	194	218	258	258
n1	110	118	126	126	135	146	168	168

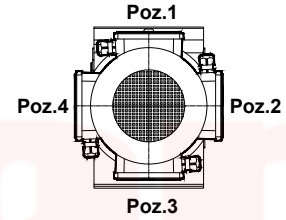

71-80-90-100-112-132  
Tip / Type / Typ

KV875.01  
KV876.01

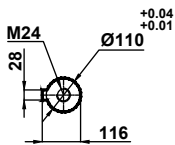
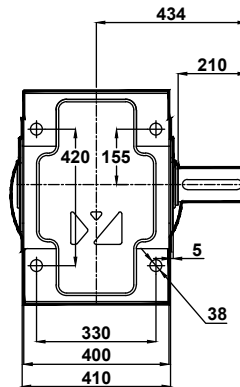
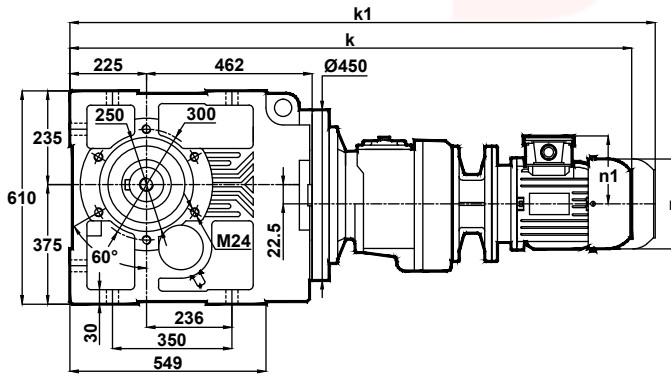

	71/B5	80/B5	90S/B5	90L/B5	100L/B5	112M/B5	132S/B5	132M/B5
k	1216	1236	1256	1281	1330	1350	1414	1452
k1	1336	1356	1381	1406	1465	1485	1559	1597
n	138	156	176	176	194	218	258	258
n1	110	118	126	126	135	146	168	168



# Ölçü Sayfaları Dimension Pages Abmessungsseiten



-Mil ucu çekirme deliği DIN 332 sayfa 2 / Tapped center hole to DIN 332, sheet 2 / Zentrierung mit gewinde DIN 332, Blatt 2

KV875.02  
KV876.02

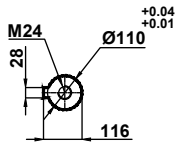
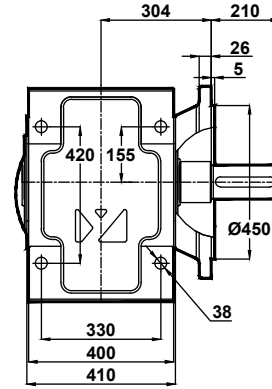
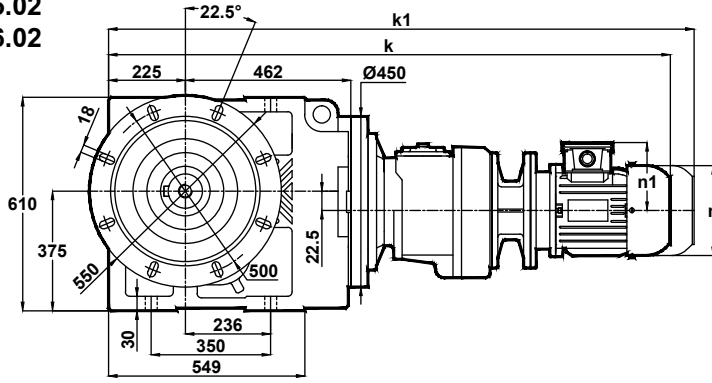

	71/B5	80/B5	90S/B5	90L/B5	100L/B5	112M/B5	132S/B5	132M/B5
k	1216	1236	1256	1281	1330	1350	1414	1452
k1	1336	1356	1381	1406	1465	1485	1559	1597
n	138	156	176	176	194	218	258	258
n1	110	118	126	126	135	146	168	168

Klemens Pozisyonları  
Terminal Box Positions  
Klemmenkasten Positionen

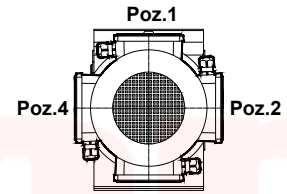

Poz.1  
Poz.2  
Poz.3  
71-80-90-100-112-132  
Tip / Type / Typ

KV875.03  
KV876.03

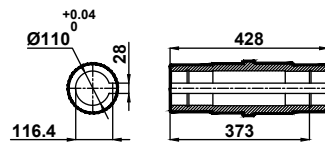
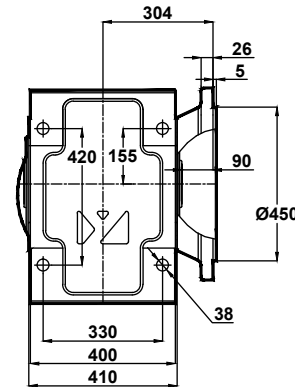
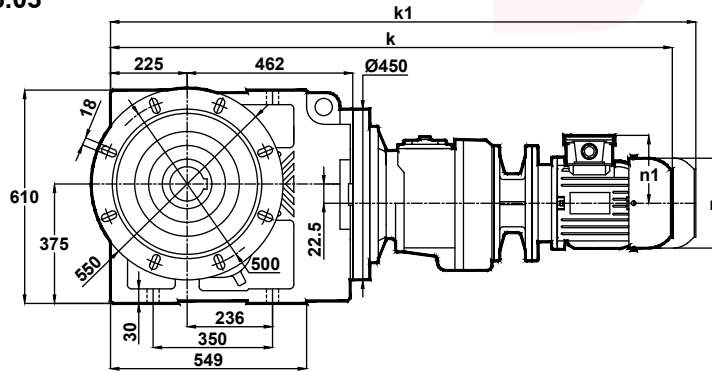

	71/B5	80/B5	90S/B5	90L/B5	100L/B5	112M/B5	132S/B5	132M/B5
k	1216	1236	1256	1281	1330	1350	1414	1452
k1	1336	1356	1381	1406	1465	1485	1559	1597
n	138	156	176	176	194	218	258	258
n1	110	118	126	126	135	146	168	168



# Ölçü Sayfaları Dimension Pages Abmessungsseiten



-Mil ucu çektirme deliği DIN 332 sayfa 2 / Tapped center hole to DIN 332, sheet 2 / Zentrierung mit gewinde DIN 332, Blatt 2

KV875.04  
KV876.04

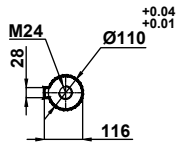
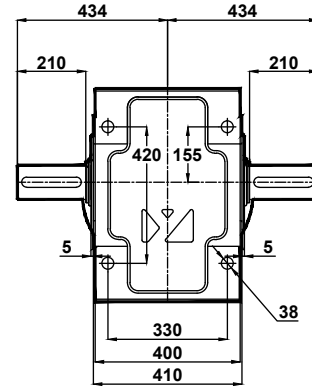
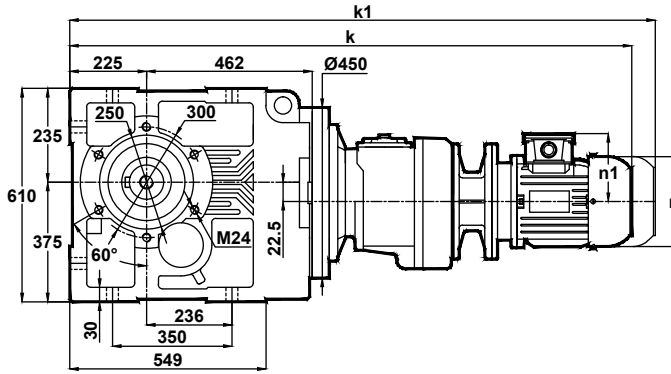

	71/B5	80/B5	90S/B5	90L/B5	100L/B5	112M/B5	132S/B5	132M/B5
k	1216	1236	1256	1281	1330	1350	1414	1452
k1	1336	1356	1381	1406	1465	1485	1559	1597
n	138	156	176	176	194	218	258	258
n1	110	118	126	126	135	146	168	168

Klemens Pozisyonları  
Terminal Box Positions  
Klemmenkasten Positionen

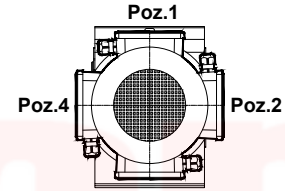

71-80-90-100-112-132  
Tip / Type / Typ

KV875.05  
KV876.05

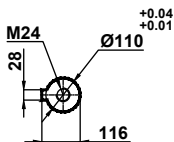
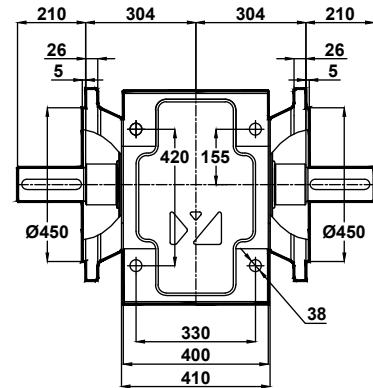
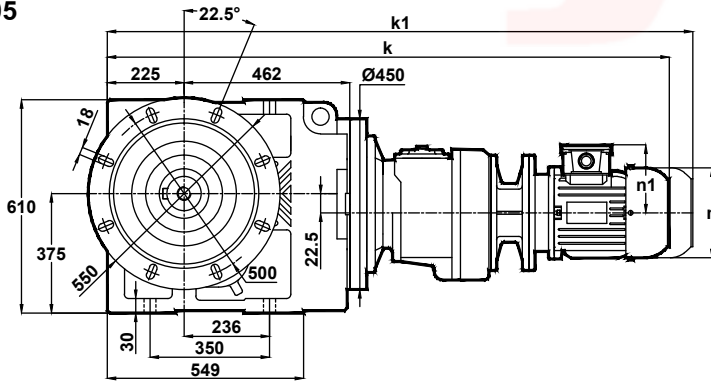

	71/B5	80/B5	90S/B5	90L/B5	100L/B5	112M/B5	132S/B5	132M/B5
k	1216	1236	1256	1281	1330	1350	1414	1452
k1	1336	1356	1381	1406	1465	1485	1559	1597
n	138	156	176	176	194	218	258	258
n1	110	118	126	126	135	146	168	168



# Ölçü Sayfaları Dimension Pages Abmessungsseiten



-Mil ucu çekirme deliği DIN 332 sayfa 2 / Tapped center hole to DIN 332, sheet 2 / Zentrierung mit gewinde DIN 332, Blatt 2

KV875.08  
KV876.08

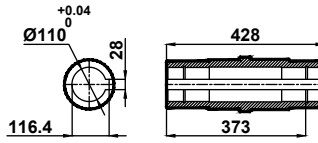
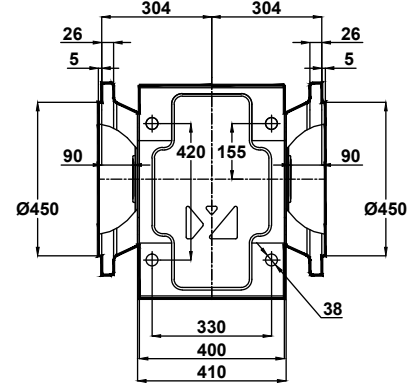
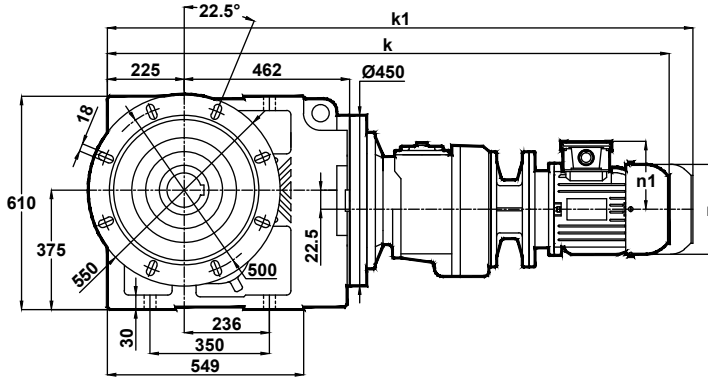

	71/B5	80/B5	90S/B5	90L/B5	100L/B5	112M/B5	132S/B5	132M/B5
k	1216	1236	1256	1281	1330	1350	1414	1452
k1	1336	1356	1381	1406	1465	1485	1559	1597
n	138	156	176	176	194	218	258	258
n1	110	118	126	126	135	146	168	168

Klemens Pozisyonları  
Terminal Box Positions  
Klemmenkasten Positionen

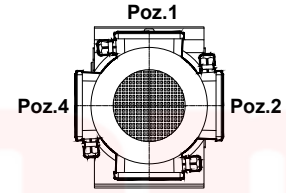

Poz.3  
71-80-90-100-112-132  
Tip / Type / Typ







# Güç ve Devir Tabloları

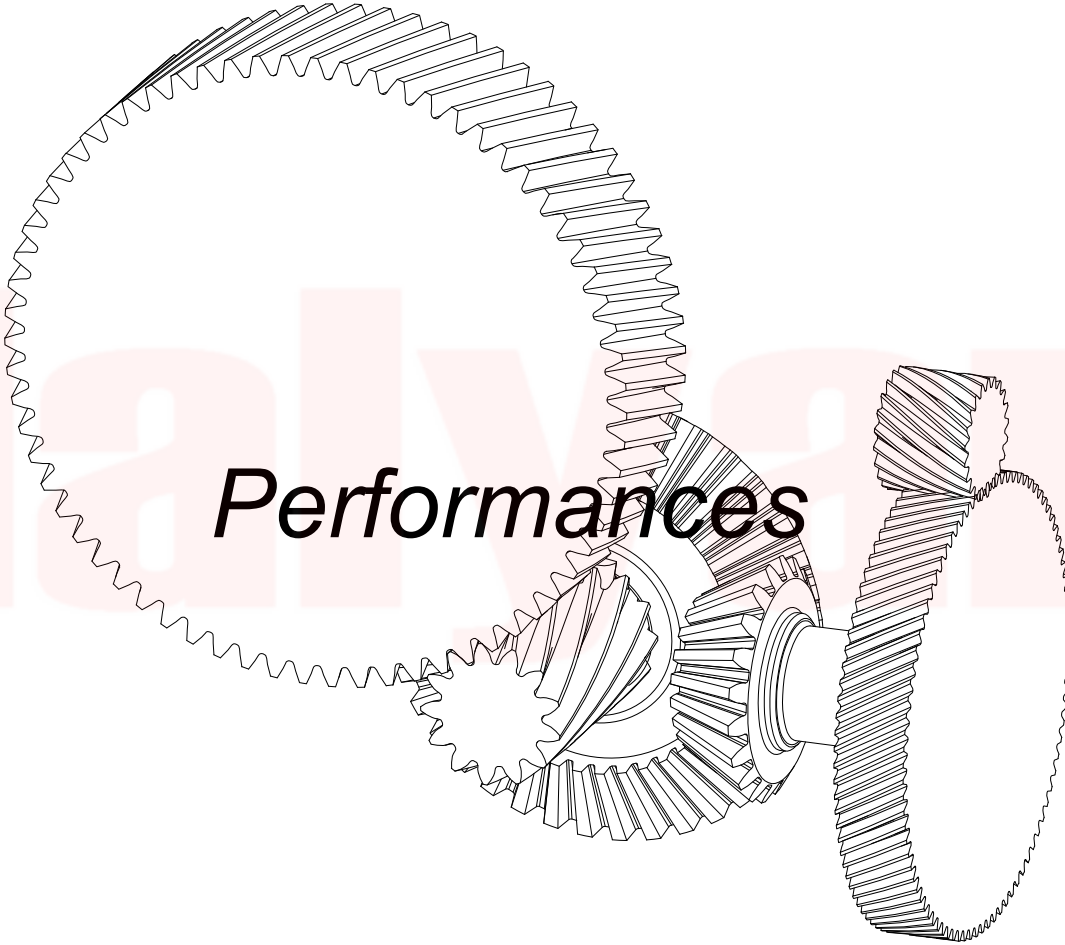

## Leistung und Drehzahlübersicht



# K Serisi Motorsuz Güç Devir Sayfaları

## K Series Gear Units Performance Tables

### K Serien Getriebe Leistung und Drehzahlübersicht



Anma Momenti Nominal Torques Nenn-drehmomente Ma [Nm] (n1=1400rpm)	Çevrim Oranı Ratio Übersetzung i	Çıkış Devri Output Speeds Abtriebs-drehzahlen n2 [r.p.m] (n1=1400rpm)	Tipi Type Typ	Pe= Nominal Güç [kW] (Servis Faktörü fs=1,0 için) Pe= Nominal Power [kW] (For Service Factor fs=1,0) Pe= NennLeistung [kW] (Bei Betriebsfaktor fs=1,0)						Güv. Rad.Yük Çıkış Per.O.Loads (Output) Zul.Querkräfte (Abtrieb) Fqam [N] (n1=1400rpm)	Güv.Rad.Yük Giriş Per.O.Loads (Input) Zul.Querkräfte (Antrieb) Fqem [N] (n1=1400rpm)	Ağırlık Weight Gewicht [kg]	Ölçü Sayfası Dim. Page Maße Seite	Fiyat Kodu Price Ref. Preis No.
				Giriş devri[d/d] / Input speed[rpm] / Antriebsdrehzahl[upm]										
				n1=2800	n1=1400	n1=900	n1=750	n1=450	n1=350					
<b>220</b>	6.94	202	<b>KT273</b>	8.5	<b>5.0</b>	3.9	3.4	2.4	2.0	10876	420	25	330	KT001
<b>230</b>	8.28	169		7.5	<b>4.3</b>	3.4	3.0	2.1	1.7	11484	525			
<b>240</b>	9.92	141		6.6	<b>3.8</b>	2.9	2.6	1.8	1.5	12152	616			
<b>250</b>	12.00	117		5.7	<b>3.3</b>	2.6	2.3	1.6	1.3	12600	696			
<b>350</b>	13.34	105		7.0	<b>4.1</b>	3.2	2.8	1.7	1.3	12600	892			
<b>370</b>	15.92	88		6.1	<b>3.6</b>	2.8	2.4	1.4	1.1	12500	954			
<b>390</b>	19.08	73		5.4	<b>3.2</b>	2.4	2.0	1.2	0.92	12400	1008			
<b>410</b>	23.08	61		4.7	<b>2.8</b>	2.0	1.6	0.98	0.76	12250	1057			
<b>430</b>	25.55	55		4.4	<b>2.6</b>	1.8	1.5	0.88	0.69	12100	1240			
<b>450</b>	30.48	46		3.9	<b>2.3</b>	1.5	1.2	0.74	0.58	12000	1255			
	36.55	38		3.4	<b>1.9</b>	1.2	1.0	0.62	0.48	12000	1280			
	44.20	32		3.0	<b>1.6</b>	1.0	0.85	0.51	0.40	12000	1303			
	50.51	28		2.7	<b>1.4</b>	0.89	0.74	0.45	0.35	12000	1316			
	58.15	24		2.4	<b>1.2</b>	0.78	0.65	0.39	0.30	12000	1328			
	68.40	20		2.1	<b>1.0</b>	0.66	0.55	0.33	0.26	12000	1340			
	72.92	19		1.9	<b>0.96</b>	0.62	0.52	0.31	0.27	12000	1344			
	83.48	17		1.7	<b>0.84</b>	0.54	0.45	0.27	0.23	12000	1352			
	96.68	14		1.5	<b>0.73</b>	0.47	0.39	0.26	0.20	12000	1360			
	113.65	12		1.2	<b>0.62</b>	0.40	0.33	0.22	0.17	12000	1367			
<b>450</b>	112.73	12	<b>KT275</b>	1.3	<b>0.66</b>	0.42	0.35	0.23	0.18	12000	592	28	334	KT002
	131.68	11		1.1	<b>0.56</b>	0.36	0.30	0.20	0.16	12000	602			
	200.35	7.0		0.74	<b>0.37</b>	0.27	0.22	0.13	0.10	12000	675			
	215.91	6.5		0.69	<b>0.34</b>	0.25	0.21	0.12	0.10	12000	678			
	252.20	5.6		0.59	<b>0.30</b>	0.21	0.18	0.11	0.08	12000	683			
	300.85	4.7		0.55	<b>0.28</b>	0.20	0.16	0.10	0.08	12000	697			
	360.73	3.9		0.46	<b>0.23</b>	0.16	0.14	0.08	0.06	12000	710			
	436.24	3.2		0.38	<b>0.19</b>	0.14	0.11	0.07	0.05	12000	720			
	498.55	2.8		0.33	<b>0.17</b>	0.12	0.10	0.06	0.05	12000	727			
	573.99	2.4		0.29	<b>0.15</b>	0.10	0.09	0.05	0.04	12000	733			
	675.13	2.1		0.27	<b>0.12</b>	0.09	0.07	0.04	0.03	12000	738			
	719.79	1.9		0.26	<b>0.12</b>	0.08	0.07	0.04	0.03	12000	740			
<b>450</b>	735.42	1.9	<b>KT276</b>	0.26	<b>0.12</b>	0.08	0.07	0.04	0.03	12000	742	30	334	KT003
	881.79	1.6		0.21	<b>0.10</b>	0.07	0.06	0.03	0.03	12000	747			
	1066.35	1.3		0.18	<b>0.08</b>	0.06	0.05	0.03	0.02	12000	751			
	1218.69	1.1		0.16	<b>0.07</b>	0.05	0.04	0.02	0.02	12000	754			
	1403.10	1.0		0.14	<b>0.06</b>	0.04	0.04	0.02	0.02	12000	756			
	1650.31	0.85		0.11	<b>0.05</b>	0.04	0.03	0.02	0.01	12000	758			
	1759.48	0.80		0.11	<b>0.05</b>	0.03	0.03	0.02	0.01	12000	759			
<b>580</b>	5.68	247	<b>KT373</b>	26	<b>16</b>	12	10	7.2	5.6	11009	-	60	338	KT004
<b>595</b>	6.63	211		23	<b>14</b>	10	9.1	6.2	4.8	11617	-			
<b>610</b>	7.73	181		20	<b>12</b>	9.1	8.1	5.3	4.1	12253	-			
<b>630</b>	8.54	164		19	<b>12</b>	8.5	7.4	4.8	3.7	12616	-			
<b>655</b>	9.97	140		17	<b>10</b>	7.5	6.6	4.1	3.2	13248	-			
<b>805</b>	10.60	132		19	<b>12</b>	7.8	6.5	3.9	3.0	12100	-			
<b>820</b>	12.38	113		17	<b>10</b>	6.6	5.5	3.3	2.6	11800	-			
	14.44	97		15	<b>8.9</b>	5.7	4.7	2.9	2.2	11800	-			
	15.96	88		14	<b>8.0</b>	5.2	4.3	2.6	2.0	11800	-			
	18.62	75		13	<b>6.9</b>	4.4	3.7	2.2	1.7	11800	-			
	21.90	64		12	<b>5.8</b>	3.8	3.1	1.9	1.5	11800	-			
	24.72	57		10	<b>5.2</b>	3.3	2.8	1.7	1.3	11800	1484			
	28.85	49		8.9	<b>4.4</b>	2.9	2.4	1.4	1.1	11800	1529			
	33.65	42		7.6	<b>3.8</b>	2.4	2.0	1.2	0.95	11800	1572			
	37.19	38		6.9	<b>3.4</b>	2.2	1.8	1.1	0.86	11800	1595			
	43.40	32		5.9	<b>3.0</b>	1.9	1.6	0.95	0.74	11800	1625			
	51.05	27		5.0	<b>2.6</b>	1.6	1.3	0.81	0.63	11800	1652			
	60.69	23		4.2	<b>2.1</b>	1.4	1.1	0.68	0.53	11800	1675			
	68.65	20		3.7	<b>1.9</b>	1.2	1.0	0.60	0.47	11800	1690			
	78.29	18		3.3	<b>1.6</b>	1.1	0.88	0.53	0.41	11800	1704			
	97.26	14		2.6	<b>1.3</b>	0.85	0.70	0.42	0.33	11800	1723			
	110.61	13		2.3	<b>1.2</b>	0.74	0.62	0.37	0.29	11800	1732			
	127.30	11		2.0	<b>1.0</b>	0.65	0.54	0.32	0.25	11800	-			



# K Serisi Motorsuz Güç Devir Sayfaları

## K Series Gear Units Performance Tables

### K Serien Getriebe Leistung und Drehzahlübersicht



Anma Momenti Nominal Torques Nenn-drehmomente Ma [Nm] (n1=1400rpm)	Çevrim Oranı Ratio Übersetzung i	Çıkış Devri Output Speeds Abtriebs-drehzahlen n2 [r.p.m] (n1=1400rpm)	Tipi Type Typ	Pe= Nominal Güç [kW] (Servis Faktörü fs=1,0 için) Pe= Nominal Power [kW] (For Service Factor fs=1,0) Pe= NennLeistung [kW] (Bei Betriebsfaktor fs=1,0)						Güv. Rad.Yük Çıkış Per.O.Loads (Output) Zul.Querkräfte (Abtrieb) Fqam [N] (n1=1400rpm)	Güv.Rad.Yük Giriş Per.O.Loads (Input) Zul.Querkräfte (Antrieb) Fqem [N] (n1=1400rpm)	Ağırlık Weight Gewicht [kg]	Ölçü Sayfası Dim. Page Maße Seite	Fiyat Kodu Price Ref. Preis No.
				Giriş devri[d/d] / Input speed[rpm] / Antriebsdrehzahl[upm]										
				n1=2800	n1=1400	n1=900	n1=750	n1=450	n1=350					
820	127.30	11	KT373	2.0	1.00	0.65	0.54	0.32	0.25	11800	-	60	338	KT004
	148.75	9		1.7	0.86	0.55	0.46	0.28	0.24	11800	-			
820	127.14	11	KT374	2.1	1.0	0.67	0.56	0.33	0.26	11800	1317	61	342	KT005
	140.49	10		1.9	0.94	0.60	0.50	0.30	0.26	11800	1241			
	163.96	8.54		1.6	0.81	0.52	0.43	0.26	0.22	11800	1374			
	192.86	7.26		1.4	0.69	0.44	0.37	0.24	0.19	11800	1403			
	229.29	6.11		1.2	0.58	0.37	0.31	0.21	0.16	11800	1429			
	259.36	5.40		1.0	0.51	0.33	0.27	0.18	0.14	11800	1445			
	295.76	4.73		0.90	0.45	0.29	0.27	0.16	0.12	11800	1460			
	367.43	3.81		0.72	0.36	0.26	0.22	0.13	0.10	11800	1481			
820	374.18	3.74	KT375	0.73	0.36	0.26	0.22	0.13	0.10	11800	927	62	346	KT006
	442.71	3.16		0.61	0.31	0.22	0.18	0.11	0.09	11800	931			
	473.96	2.95		0.57	0.29	0.20	0.17	0.10	0.08	11800	932			
	536.75	2.61		0.51	0.25	0.18	0.15	0.09	0.07	11800	934			
	593.11	2.36		0.51	0.26	0.18	0.15	0.09	0.07	11800	939			
	692.22	2.02		0.44	0.22	0.16	0.13	0.08	0.06	11800	947			
	814.20	1.72		0.37	0.19	0.13	0.11	0.07	0.05	11800	953			
	968.01	1.4		0.31	0.16	0.11	0.09	0.06	0.04	11800	960			
	1094.97	1.3		0.28	0.14	0.10	0.08	0.05	0.04	11800	963			
	820	1184.90		1.2	KT376	0.26	0.13	0.09	0.08	0.05	0.04			
1401.91		1.0	0.25	0.11		0.08	0.07	0.04	0.03	11800	972			
1500.87		0.93	0.23	0.10		0.07	0.06	0.04	0.03	11800	973			
1699.70		0.82	0.20	0.09		0.07	0.05	0.03	0.03	11800	973			
1878.17		0.75	0.18	0.08		0.06	0.05	0.03	0.02	11800	975			
2192.03		0.64	0.16	0.07		0.05	0.04	0.03	0.02	11800	978			
2578.32		0.54	0.13	0.06		0.04	0.04	0.02	0.02	11800	980			
3065.37		0.46	0.11	0.05		0.04	0.03	0.02	0.01	11800	982			
3467.39		0.40	0.10	0.04		0.03	0.03	0.02	0.01	11800	983			
830 865 905 935 970 1005 1370 1425 1485 1550		6.21	225	KT473		34	21	15	13	9.4	7.9	12444	-	96
	7.48	187	29		18	13	11	8.1	6.8	13228	-			
	9.06	154	25		16	11	9.5	7.0	5.9	14068	-			
	10.34	135	23		14	10	8.6	6.4	5.4	14673	-			
	11.87	118	21		13	9.3	7.8	5.8	4.8	15314	-			
	13.71	102	19		11	8.4	7.0	5.2	4.3	16035	-			
	15.33	91	23		14	10	8.5	5.1	3.9	16405	-			
	17.49	80	21		13	8.9	7.4	4.4	3.5	17070	-			
	20.07	70	19		12	7.7	6.5	3.9	3.0	17000	-			
	23.19	60	17		10	6.7	5.6	3.4	2.6	17000	-			
	23.76	59	17		10	6.5	5.5	3.3	2.5	17000	-			
	25.15	56	16		9.7	6.2	5.2	3.1	2.4	17000	-			
	30.11	46	14		8.0	5.1	4.3	2.6	2.0	17000	-			
	39.11	36	11		6.2	4.0	3.3	2.0	1.6	17000	1591			
	44.64	31	10		5.4	3.5	2.9	1.7	1.4	17000	1630			
	51.22	27	9.3		4.7	3.0	2.5	1.5	1.9	17000	1665			
	59.19	24	8.2		4.1	2.6	2.2	1.3	1.0	17000	1698			
	60.63	23	8.0		4.0	2.6	2.1	1.3	1.0	17000	1704			
64.17	22	7.5	3.8	2.4	2.0	1.2	0.94	17000	1716					
76.83	18	6.3	3.2	2.0	1.7	1.0	0.79	17000	1747					
87.49	16	5.5	2.8	1.8	1.5	0.89	0.69	17000	1766					
97.79	14	4.9	2.5	1.6	1.3	0.79	0.62	17000	1783					
110.65	13	4.3	2.2	1.4	1.2	0.70	0.55	17000	1797					
135.98	10	3.6	1.8	1.1	0.95	0.57	0.44	17000	1818					
153.47	9.1	3.2	1.6	1.0	0.84	0.51	0.39	17000	1827					
1550	160.79	8.7	KT474	31	1.5	0.99	0.83	0.50	0.39	17000	1786	98	354	KT009
	181.88	7.7		2.7	1.4	0.88	0.73	0.44	0.34	17000	1797			
	207.41	6.7		2.4	1.2	0.77	0.64	0.39	0.30	17000	1806			
	242.51	5.8		2.1	1.0	0.66	0.55	0.33	0.26	17000	1816			



# K Serisi Motorsuz Güç Devir Sayfaları

## K Series Gear Units Performance Tables

### K Serien Getriebe Leistung und Drehzahlübersicht



Anma Momenti Nominal Torques Nenn-drehmomente Ma [Nm] (n1=1400rpm)	Çevrim Oranı Ratio Übersetzung i	Çıkış Devri Output Speeds Abtriebs-drehzahlen n2 [r.p.m] (n1=1400rpm)	Tipi Type Typ	Pe= Nominal Güç [kW] (Servis Faktörü fs=1,0 için) Pe= Nominal Power [kW] (For Service Factor fs=1,0) Pe= Nennleistung [kW] (Bei Betriebsfaktor fs=1,0)						Güv. Rad.Yük Çıkış Per.O.Loads (Output)	Güv.Rad.Yük Giriş Per.O.Loads (Input)	Ağırlık Weight Gewicht [kg]	Ölçü Sayfası Dim. Page Maße Seite	Fiyat Kodu Price Ref. Preis No.					
				Giriş devri[d/d] / Input speed[rpm] / Antriebsdrehzahl[upm]						Zul.Querkräfte (Abtrieb)	Zul.Querkräfte (Antrieb)								
				n1=2800	n1=1400	n1=900	n1=750	n1=450	n1=350	Fqam [N] (n1=1400rpm)	Fqem [N] (n1=1400rpm)								
1550	293.03	4.8	KT474	1.7	0.85	0.55	0.46	0.27	0.24	17000	1827	98	354	KT009					
	310.16	4.5		1.6	0.81	0.52	0.43	0.26	0.22	17000	1837								
	371.35	3.8		1.4	0.67	0.43	0.36	0.24	0.19	17000	1874								
	422.88	3.3		1.2	0.59	0.38	0.32	0.21	0.16	17000	1896								
	472.63	3.0		1.0	0.53	0.34	0.28	0.19	0.15	17000	1912								
1550	509.34	2.7	KT475	1.0	0.50	0.32	0.27	0.18	0.14	17000	1504	101	358	KT010					
	610.72	2.3		0.84	0.42	0.27	0.25	0.15	0.12	17000	1509								
	655.16	2.1		0.78	0.39	0.25	0.23	0.14	0.11	17000	1510								
	738.55	1.9		0.69	0.35	0.25	0.21	0.12	0.10	17000	1513								
	844.06	1.7		0.61	0.30	0.22	0.18	0.11	0.08	17000	1516								
	901.03	1.6		0.57	0.29	0.20	0.17	0.10	0.08	17000	1517								
	971.77	1.4		0.53	0.26	0.19	0.16	0.09	0.07	17000	1519								
	1142.99	1.2		0.50	0.25	0.18	0.15	0.09	0.07	17000	1521								
	1218.61	1.1		0.47	0.24	0.17	0.14	0.08	0.07	17000	1522								
	1395.04	1.0		0.41	0.21	0.15	0.12	0.07	0.06	17000	1524								
	1476.60	0.95		0.39	0.19	0.14	0.12	0.07	0.05	17000	1526								
	1767.90	0.79		0.33	0.16	0.12	0.10	0.06	0.05	17000	1533								
	1550	2183.54		0.64	KT476	0.27	0.13	0.10	0.08	0.05	0.04				17000	1550	104	358	KT011
2495.47		0.56	0.26	0.12		0.08	0.07	0.04	0.03	17000	1551								
2663.91		0.53	0.24	0.11		0.08	0.07	0.04	0.03	17000	1551								
2873.07		0.49	0.23	0.10		0.07	0.06	0.04	0.03	17000	1551								
3379.28		0.41	0.19	0.09		0.06	0.05	0.03	0.02	17000	1552								
3602.83		0.39	0.18	0.08		0.06	0.05	0.03	0.02	17000	1552								
4124.46		0.34	0.16	0.07		0.05	0.04	0.03	0.02	17000	1553								
4365.60		0.32	0.15	0.07		0.05	0.04	0.02	0.02	17000	1554								
5226.85		0.27	0.13	0.06		0.04	0.03	0.02	0.02	17000	1556								
1220 1300 1380 1470 1700 1820 1930 2050 2100 2200 2300 2300 2430 2500 2620 2700		6.91	203	KT573		-	28	20	18	12	10	19926	-	138	362	KT012			
		8.07	173			-	25	21	16	11	9.3	20771	-						
	9.48	148	37		23	17	15	10	8.6	21719	-								
	11.22	125	33		20	15	13	9.2	7.8	22753	-								
	11.58	121	-		23	17	15	10	8.7	22685	-								
	13.53	104	-		21	15	14	9.5	7.8	23595	-								
	15.88	88	31		19	14	13	8.5	6.6	24671	-								
	18.80	74	28		17	13	11	7.2	5.6	25860	-								
	20.24	69	27		16	12	11	6.7	5.2	26421	-								
	22.77	61	25		15	11	9.8	5.9	4.6	27263	-								
	25.78	54	23		14	10	8.8	5.3	4.1	28225	-								
	30.25	46	-		12	8.7	7.5	4.5	3.5	29000	2812								
	35.34	40	-		11	7.7	6.4	3.8	3.0	27500	2834								
	38.16	37	17		10	7.1	5.9	3.6	2.8	26000	2865								
	44.73	31	15		9.1	6.1	5.0	3.0	2.4	24500	2886								
	52.88	26	13		8.0	5.1	4.3	2.6	2.0	22500	2919								
	59.49	24	12		7.1	4.6	3.8	2.3	1.8	22500	2954								
67.37	21	11	6.3	4.0	3.4	2.0	1.6	22500	2988										
82.14	17	9.9	5.1	3.3	2.8	1.7	1.3	22500	3031										
97.19	14	8.7	4.3	2.8	2.3	1.4	1.1	22500	3063										
109.86	13	7.7	3.8	2.5	2.1	1.2	0.96	22500	3083										
125.51	11	6.7	3.4	2.2	1.8	1.1	0.84	22500	3102										
2700	117.96	12	KT574	7.3	3.7	2.4	2.0	1.2	0.91	22500	1500	140	366	KT013					
	140.24	10		6.2	3.1	2.0	1.7	0.99	0.77	22500	1533								
	158.64	8.83		5.5	2.7	1.8	1.5	0.88	0.68	22500	1553								
	180.90	7.74		4.8	2.4	1.5	1.3	0.77	0.60	22500	1572								
	211.51	6.62		4.1	2.1	1.3	1.1	0.66	0.51	22500	1592								
	237.97	5.88		3.7	1.8	1.2	0.98	0.59	0.46	22500	1643								
	246.42	5.68		3.5	1.8	1.1	0.94	0.57	0.44	22500	1731								
	281.00	4.98		3.1	1.6	0.99	0.83	0.50	0.39	22500	1743								
	328.56	4.26		2.7	1.3	0.85	0.71	0.43	0.33	22500	1756								
	397.01	3.53		2.2	1.1	0.71	0.59	0.35	0.27	22500	1769								
	469.74	2.98		1.9	0.93	0.60	0.50	0.30	0.26	22500	1813								



# K Serisi Motorsuz Güç Devir Sayfaları

## K Series Gear Units Performance Tables

### K Serien Getriebe Leistung und Drehzahlübersicht



Anma Momenti Nominal Torques Nenn-drehmomente Ma [Nm] (n1=1400rpm)	Çevrim Oranı Ratio Übersetzung i	Çıkış Devri Output Speeds Abtriebs-drehzahlen n2 [r.p.m] (n1=1400rpm)	Tipi Type Typ	Pe= Nominal Güç [kW] (Servis Faktörü fs=1,0 için) Pe= Nominal Power [kW] (For Service Factor fs=1,0) Pe= NennLeistung [kW] (Bei Betriebsfaktor fs=1,0)						Güv. Rad.Yük Çıkış Per.O.Loads (Output)	Güv.Rad.Yük Giriş Per.O.Loads (Input)	Ağırlık Weight Gewicht [kg]	Ölçü Sayfası Dim. Page Maße Seite	Fiyat Kodu Price Ref. Preis No.
				Giriş devri[d/d] / Input speed[rpm] / Antriebsdrehzahl[upm]										
				n1=2800	n1=1400	n1=900	n1=750	n1=450	n1=350					
<b>2700</b>	507.09	2.76	<b>KT575</b>	1.8	<b>0.88</b>	0.57	0.47	0.28	0.25	22500	1356	140	370	KT014
	570.53	2.45		1.6	<b>0.78</b>	0.50	0.42	0.25	0.22	22500	1380			
	787.70	1.78		1.1	<b>0.57</b>	0.37	0.30	0.20	0.16	22500	1431			
	932.00	1.50		0.96	<b>0.48</b>	0.31	0.26	0.17	0.13	22500	1453			
	1216.74	1.2		0.74	<b>0.37</b>	0.26	0.22	0.13	0.10	22500	1478			
	1368.95	1.0		0.66	<b>0.33</b>	0.23	0.20	0.12	0.09	22500	1488			
	1890.04	0.74		0.53	<b>0.26</b>	0.19	0.16	0.09	0.07	22500	1510			
	2236.28	0.63		0.45	<b>0.22</b>	0.16	0.13	0.08	0.06	22500	1519			
<b>2700</b>	2328.84	0.60	<b>KT576</b>	0.44	<b>0.22</b>	0.16	0.13	0.08	0.06	22500	1523	145	370	KT015
	2755.47	0.51		0.37	<b>0.19</b>	0.13	0.11	0.07	0.05	22500	1530			
	3597.31	0.39		0.28	<b>0.14</b>	0.10	0.08	0.05	0.04	22500	1538			
	4047.32	0.35		0.25	<b>0.13</b>	0.09	0.08	0.05	0.04	22500	1541			
	5587.93	0.25		0.20	<b>0.09</b>	0.07	0.05	0.03	0.03	22500	1549			
	6611.61	0.21		0.17	<b>0.08</b>	0.06	0.05	0.03	0.02	22500	1552			
<b>2500</b> <b>2600</b> <b>2700</b> <b>2800</b> <b>2900</b> <b>4300</b>	8.31	169	<b>KT673</b>	-	<b>47</b>	35	31	21	17.8	25155	-	235	374	KT016
	9.45	148		-	<b>43</b>	31	28	19	15.7	26140	-			
	10.81	130		-	<b>39</b>	29	25	18	13.7	27248	-			
	12.46	112		56	<b>35</b>	26	23	15	11.9	28510	-			
	14.49	97		51	<b>31</b>	23	20	13	10.2	29970	-			
	16.54	85		-	<b>41</b>	26	22	13	10.1	26490	-			
	18.74	75		-	<b>36</b>	23	19	12	9.0	28202	-			
	21.32	66		-	<b>31</b>	20	17	10	7.9	29600	-			
	24.38	57		-	<b>28</b>	18	15	8.8	6.9	29600	-			
	28.10	50		48	<b>24</b>	15	13	7.7	6.0	29600	-			
	32.68	43		41	<b>21</b>	13	11	6.6	5.1	29600	-			
	39.26	36		-	<b>17</b>	11	9.2	5.5	4.3	29600	3205			
	44.65	31		-	<b>15</b>	9.7	8.1	4.8	3.8	29600	3276			
	51.08	27		-	<b>13</b>	8.4	7.0	4.2	3.3	29600	3340			
	58.86	24		23	<b>11</b>	7.3	6.1	3.7	2.9	29600	3400			
	68.47	20		20	<b>9.8</b>	6.3	5.3	3.2	2.5	29600	3454			
	80.38	17		17	<b>8.3</b>	5.4	4.5	2.7	2.1	29600	3520			
	90.21	16		15	<b>7.4</b>	4.8	4.0	2.4	1.9	29600	3551			
100.90	14	13	<b>6.7</b>	4.3	3.6	2.1	1.7	29600	3569					
128.24	11	10	<b>5.2</b>	3.4	2.8	1.7	1.3	29600	3626					
<b>4300</b>	123.38	11	<b>KT674</b>	11	<b>5.6</b>	3.6	3.0	1.8	1.4	29600	687	238	378	KT017
	140.49	10		9.8	<b>4.9</b>	3.1	2.6	1.6	1.2	29600	808			
	157.02	8.9		8.7	<b>4.4</b>	2.8	2.3	1.4	1.1	29600	920			
	178.62	7.8		7.7	<b>3.9</b>	2.5	2.1	1.2	0.96	29600	1342			
	204.32	6.9		6.7	<b>3.4</b>	2.2	1.8	1.1	0.84	29600	1616			
	235.44	5.9		5.9	<b>2.9</b>	1.9	1.6	0.94	0.73	29600	1702			
	273.88	5.1		5.0	<b>2.5</b>	1.6	1.4	0.81	0.63	29600	1781			
	321.51	4.4		4.3	<b>2.1</b>	1.4	1.2	0.69	0.54	29600	1853			
	363.81	3.8		3.8	<b>1.9</b>	1.2	1.0	0.61	0.47	29600	1865			
	<b>4300</b>	423.90		3.3	<b>KT675</b>	3.3	<b>1.7</b>	1.1	0.89	0.53	0.42			
489.82		2.9	2.9	<b>1.4</b>		0.93	0.77	0.46	0.36	29600	1863			
531.08		2.6	2.7	<b>1.3</b>		0.85	0.71	0.43	0.33	29600	1869			
635.86		2.2	2.2	<b>1.1</b>		0.72	0.60	0.36	0.28	29600	1880			
724.08		1.9	2.0	<b>0.98</b>		0.63	0.52	0.31	0.27	29600	1886			
809.27		1.7	1.8	<b>0.88</b>		0.56	0.47	0.28	0.24	29600	1892			
915.75		1.5	1.6	<b>0.78</b>		0.50	0.42	0.28	0.22	29600	1897			
1041.68		1.3	1.4	<b>0.68</b>		0.44	0.37	0.24	0.19	29600	1916			
1191.60		1.2	1.2	<b>0.60</b>		0.38	0.32	0.21	0.17	29600	1933			
1373.07		1.0	1.0	<b>0.52</b>		0.33	0.28	0.19	0.14	29600	1949			
1597.25		0.88	0.89	<b>0.45</b>		0.29	0.27	0.16	0.12	29600	1963			
1875.03		0.75	0.76	<b>0.38</b>		0.27	0.23	0.14	0.11	29600	1977			
<b>4300</b>		1884.33	0.74	<b>KT676</b>		0.77	<b>0.39</b>	0.28	0.23	0.14	0.11	29600	2009	250



# K Serisi Motorsuz Güç Devir Sayfaları

## K Series Gear Units Performance Tables

### K Serien Getriebe Leistung und Drehzahlübersicht



Anma Momenti Nominal Torques Nenn-drehmomente Ma [Nm] (n1=1400rpm)	Çevrim Oranı	Çıkış Devri	Tipi Type Typ	Pe= Nominal Güç [kW] (Servis Faktörü fs=1,0 için) Pe= Nominal Power [kW] (For Service Factor fs=1,0) Pe= NennLeistung [kW] (Bei Betriebsfaktor fs=1,0)						Güv. Rad.Yük Çıkış	Güv.Rad.Yük Giriş	Ağırlık	Ölçü Sayfası	Fiyat Kodu
	Ratio	Output Speeds		Giriş devri[d/d] / Input speed[rpm] / Antriebsdrehzahl[upm]						Per.O.Loads (Output)	Per.O.Loads (Input)	Weight	Dim. Page	Price Ref.
	Übersetzung	Abtriebs-drehzahlen								Zul.Querkräfte (Abtrieb)	Zul.Querkräfte (Antrieb)	Gewicht	Maße Seite	Preis No.
	i	n2 [r.p.m] (n1=1400rpm)		n1=2800	n1=1400	n1=900	n1=750	n1=450	n1=350	Fqam [N] (n1=1400rpm)	Fqem [N] (n1=1400rpm)	[kg]		
<b>4300</b>	2082.19 2430.14 2858.39 3398.35 3844.04 4383.55 5445.72 6193.17 7044.81 8058.67 9285.97 10802.05 12680.66	0.67 0.58 0.49 0.41 0.36 0.32 0.26 0.23 0.20 0.17 0.15 0.13 0.11	<b>KT676</b>	0.70 0.60 0.51 0.48 0.42 0.37 0.30 0.26 0.26 0.23 0.20 0.17 0.14	<b>0.35</b> <b>0.30</b> <b>0.26</b> <b>0.24</b> <b>0.21</b> <b>0.19</b> <b>0.15</b> <b>0.13</b> <b>0.12</b> <b>0.10</b> <b>0.09</b> <b>0.08</b> <b>0.06</b>	0.25 0.21 0.18 0.17 0.15 0.13 0.11 0.09 0.08 0.07 0.06 0.05 0.04	0.21 0.18 0.15 0.14 0.13 0.11 0.09 0.08 0.07 0.06 0.05 0.03 0.02	0.12 0.11 0.09 0.09 0.08 0.07 0.05 0.04 0.03 0.03 0.02 0.02 0.02	0.10 0.08 0.07 0.07 0.06 0.05 0.04 0.04 0.03 0.03 0.02 0.02 0.02	29600 29600 29600 29600 29600 29600 29600 29600 29600 29600 29600 29600 29600	2011 2014 2016 2018 2020 2021 2023 2024 2027 2030 2033 2036 2038	250	382	KT019
<b>3900</b> <b>4050</b> <b>4200</b> <b>4250</b> <b>4400</b> <b>4500</b> <b>7250</b> <b>7550</b> <b>7900</b> <b>8000</b>	7.41 8.52 9.83 10.20 11.44 12.89 15.25 17.52 20.23 20.97 23.52 26.52 29.40 33.78 39.00 40.44 45.36 51.13 58.00 66.32 76.59 88.57 99.00 111.63	189 164 142 137 122 109 92 80 69 67 60 53 48 41 36 35 31 27 24 21 18 16 14 13	<b>KT773</b>	- - - - - - - - - - - - - - - - - - - 38 33 28 25 22	<b>77</b> <b>70</b> <b>63</b> <b>61</b> <b>56</b> <b>51</b> <b>70</b> <b>63</b> <b>57</b> <b>56</b> <b>50</b> <b>44</b> <b>40</b> <b>35</b> <b>30</b> <b>29</b> <b>26</b> <b>23</b> <b>20</b> <b>18</b> <b>15</b> <b>13</b> <b>12</b> <b>11</b>	60 54 49 48 44 40 53 46 40 38 34 30 27 24 21 20 18 16 14 12 10 9 8.1 7.2	53 48 43 42 39 35 44 38 33 32 28 25 23 20 17 16 15 13 12 10 7.6 6.8 6.0	37 34 30 29 25 23 20 19 18 15 13 12 11 9.2 8.0 7.7 6.9 6.1 5.4 4.7 4.1 3.5 3.2 2.8	31 27 23 22 20 18 20 15 15 13 12 11 9.2 8.0 7.7 6.9 6.1 5.4 4.7 4.1 3.5 3.2 2.8	34068 35582 37261 37654 38968 40635 37126 38736 40382 40780 43151 45714 47999 51188 54628 55522 55500 55500 55500 55500 55500 55500 55500 55500	- - - - - - - - - - - - 2086 2708 3265 3286 3666 4019 4208 4284 4355 4434 4475 4515	360	386	KT020
<b>8000</b>	127.11 142.56 160.70 182.29 208.42 240.71 278.35 311.14 354.32 396.00	11 10 8.7 7.7 6.7 5.8 5.0 4.5 4.0 3.5	<b>KT774</b>	20 18 16 14 12 11 9.2 8.2 7.2 6.5	<b>10</b> <b>8.9</b> <b>7.9</b> <b>7.0</b> <b>6.1</b> <b>5.3</b> <b>4.6</b> <b>4.1</b> <b>3.6</b> <b>3.2</b>	6.4 5.7 5.1 4.5 3.9 3.4 3.0 2.6 2.3 2.1	5.4 4.8 4.2 3.7 3.3 2.8 2.5 2.2 1.9 1.7	3.2 2.9 2.5 2.2 2.0 1.7 1.5 1.3 1.2 1.0	2.5 2.2 2.0 1.8 1.5 1.3 1.2 1.0 0.90 0.81	55000 55000 55000 55000 55000 55000 55000 55000 55000 55000	- - - - 326 874 1351 1601 1625 1647	370	390	KT021
<b>8000</b>	436.74 504.65 547.17 655.11 746.01 833.78 943.49 1058.16 1192.77 1353.02 1547.01 1786.65	3.2 2.8 2.6 2.1 1.9 1.7 1.5 1.3 1.2 1.0 0.90 0.78	<b>KT775</b>	6.0 5.2 4.8 4.0 3.5 3.2 2.8 2.5 2.2 2.0 1.7 1.5	<b>3.0</b> <b>2.6</b> <b>2.4</b> <b>2.0</b> <b>1.8</b> <b>1.6</b> <b>1.4</b> <b>1.3</b> <b>1.1</b> <b>0.98</b> <b>0.85</b> <b>0.74</b>	1.9 1.7 1.5 1.3 1.1 1.0 0.90 0.80 0.71 0.63 0.55 0.48	1.6 1.4 1.3 1.1 0.94 0.85 0.75 0.67 0.59 0.52 0.46 0.40	0.96 0.83 0.77 0.64 0.57 0.51 0.45 0.40 0.36 0.31 0.27 0.24 0.21	0.75 0.65 0.60 0.50 0.44 0.39 0.35 0.31 0.28 0.27 0.24 0.21	55000 55000 55000 55000 55000 55000 55000 55000 55000 55000 55000 55000	1686 1706 1717 1737 1749 1759 1768 1799 1827 1854 1879 1902	381	394	KT022



# K Serisi Motorsuz Güç Devir Sayfaları

## K Series Gear Units Performance Tables

### K Serien Getriebe Leistung und Drehzahlübersicht



Anma Momenti Nominal Torques Nenn-drehmomente Ma [Nm] (n1=1400rpm)	Çevrim Oranı Ratio Übersetzung i	Çıkış Devri Output Speeds Abtriebs-drehzahlen n2 [r.p.m] (n1=1400rpm)	Tipi Type Typ	Pe= Nominal Güç [kW] (Servis Faktörü fs=1,0 için) Pe= Nominal Power [kW] (For Service Factor fs=1,0) Pe= NennLeistung [kW] (Bei Betriebsfaktor fs=1,0)						Güv. Rad.Yük Çıkış Per.O.Loads (Output)	Güv.Rad.Yük Giriş Per.O.Loads (Input)	Ağırlık Weight Gewicht [kg]	Ölçü Sayfası Dim. Page Maße Seite	Fiyat Kodu Price Ref. Preis No.
				Giriş devri[d/d] / Input speed[rpm] / Antriebsdrehzahl[upm]										
				n1=2800	n1=1400	n1=900	n1=750	n1=450	n1=350					
<b>8000</b>	2066.04	0.68	<b>KT775</b>	1.3	<b>0.64</b>	0.41	0.34	0.23	0.18	55000	1923	381	394	KT022
	2539.01	0.55		1.0	<b>0.52</b>	0.34	0.28	0.19	0.14	55000	1928			
	2838.16	0.49		0.93	<b>0.47</b>	0.30	0.25	0.17	0.13	55000	1941			
	3203.12	0.44		0.83	<b>0.41</b>	0.27	0.25	0.15	0.11	55000	1944			
<b>8000</b>	1941.39	0.72	<b>KT776</b>	1.4	<b>0.69</b>	0.45	0.37	0.25	0.19	55000	1974	386	394	KT023
	2145.24	0.65		1.3	<b>0.63</b>	0.40	0.34	0.22	0.17	55000	1978			
	2503.73	0.56		1.1	<b>0.54</b>	0.35	0.29	0.19	0.15	55000	1983			
	2944.95	0.48		0.92	<b>0.46</b>	0.30	0.27	0.16	0.13	55000	1987			
	3501.26	0.40		0.77	<b>0.39</b>	0.28	0.23	0.14	0.11	55000	1991			
	3960.44	0.35		0.69	<b>0.34</b>	0.24	0.20	0.12	0.10	55000	1993			
	4516.30	0.31		0.60	<b>0.30</b>	0.22	0.18	0.11	0.08	55000	1996			
	5610.63	0.25		0.54	<b>0.27</b>	0.19	0.16	0.10	0.07	55000	1999			
	6380.72	0.22		0.47	<b>0.24</b>	0.17	0.14	0.08	0.07	55000	2000			
	7156.22	0.20		0.42	<b>0.21</b>	0.15	0.13	0.08	0.06	55000	2006			
	8066.59	0.17		0.38	<b>0.19</b>	0.13	0.11	0.07	0.05	55000	2011			
	9150.37	0.15		0.33	<b>0.17</b>	0.12	0.10	0.06	0.05	55000	2016			
	10462.31	0.13		0.29	<b>0.15</b>	0.10	0.09	0.05	0.04	55000	2021			
	12082.94	0.12		0.25	<b>0.13</b>	0.09	0.07	0.04	0.03	55000	2025			
	13972.49	0.10		0.24	<b>0.11</b>	0.08	0.06	0.04	0.03	55000	2029			
	15618.73	0.09		0.22	<b>0.10</b>	0.07	0.06	0.03	0.03	55000	2031			
<b>7850</b> <b>8100</b> <b>8350</b> <b>8650</b> <b>12600</b> <b>13100</b> <b>13550</b> <b>14100</b> <b>13300</b> <b>13800</b> <b>14250</b> <b>14750</b> <b>15000</b>	9.63	145	<b>KT873</b>	-	<b>127</b>	93	80	48	37	60190	-	615	398	KT024
	11.05	127		-	<b>114</b>	83	70	42	32	62966	-			
	12.25	114		-	<b>106</b>	75	63	38	29	64949	-			
	13.93	101		-	<b>97</b>	66	55	33	26	67591	-			
	16.78	83		-	<b>117</b>	86	75	45	35	65717	-			
	19.26	73		-	<b>106</b>	78	65	39	30	68567	-			
	21.34	66		-	<b>99</b>	70	59	35	27	70611	-			
	24.28	58		-	<b>91</b>	62	52	31	24	73348	-			
	29.88	47		-	<b>69</b>	50	42	25	20	82509	-			
	34.28	41		-	<b>63</b>	44	37	22	17	86143	-			
	38.00	37		-	<b>58</b>	40	33	20	15	83500	-			
	43.22	32		-	<b>53</b>	35	29	17	14	79500	-			
	49.75	28		-	<b>47</b>	30	25	15	12	76000	-			
	55.53	25		-	<b>42</b>	27	23	14	11	76000	-			
	62.42	22		-	<b>37</b>	24	20	12	9.4	76000	-			
	70.76	20		61	<b>33</b>	21	18	11	8.3	76000	266			
	81.06	17		55	<b>29</b>	19	15	9.3	7.2	76000	1059			
92.80	15	50	<b>25</b>	16	14	8.1	6.3	76000	1618					
103.24	14	45	<b>23</b>	15	12	7.3	5.7	76000	2100					
115.87	12	40	<b>20</b>	13	11	6.5	5.1	76000	2567					
<b>15000</b>	86.63	16	<b>KT874</b>	55	<b>27</b>	18	15	8.8	6.8	76000	-	630	402	KT025
	98.53	14		48	<b>24</b>	15	13	7.7	6.0	76000	-			
	113.42	12		42	<b>21</b>	13	11	6.7	5.2	76000	-			
	126.62	11		37	<b>19</b>	12	10	6.0	4.7	76000	-			
	142.32	10		33	<b>17</b>	11	8.9	5.4	4.2	76000	466			
	161.34	8.7		29	<b>15</b>	9.5	7.9	4.7	3.7	76000	1260			
	184.83	7.6		26	<b>13</b>	8.3	6.9	4.1	3.2	76000	2069			
	207.95	6.7		23	<b>11</b>	7.4	6.1	3.7	2.9	76000	2278			
	235.47	5.9		20	<b>10</b>	6.5	5.4	3.3	2.5	76000	2474			
	287.10	4.9		17	<b>8.3</b>	5.4	4.5	2.7	2.1	76000	2653			
	339.70	4.1		14	<b>7.1</b>	4.5	3.8	2.3	1.8	76000	2702			
	383.99	3.6		12	<b>6.2</b>	4.0	3.4	2.0	1.6	76000	2732			
	438.70	3.2		11	<b>5.5</b>	3.5	2.9	1.8	1.4	76000	2761			
<b>15000</b>	463.83	3.0	<b>KT875</b>	11	<b>5.3</b>	3.4	2.8	1.7	1.3	76000	-	640	406	KT026
	514.05	2.7		9.5	<b>4.8</b>	3.1	2.6	1.5	1.2	76000	-			
	584.66	2.4		8.4	<b>4.2</b>	2.7	2.3	1.4	1.1	76000	-			
	673.01	2.1		7.3	<b>3.6</b>	2.3	2.0	1.20	0.91	76000	-			
	751.30	1.9		6.5	<b>3.3</b>	2.1	1.8	1.1	0.82	76000	-			



# K Serisi Motorsuz Güç Devir Sayfaları

## K Series Gear Units Performance Tables

### K Serien Getriebe Leistung und Drehzahlübersicht



Anma Momenti Nominal Torques Nenn-drehmomente Ma [Nm] (n1=1400rpm)	Çevrim Oranı Ratio Übersetzung i	Çıkış Devri Output Speeds Abtriebs-drehzahlen n2 [r.p.m] (n1=1400rpm)	Tipi Type Typ	Pe= Nominal Güç [kW] (Servis Faktörü fs=1,0 için) Pe= Nominal Power [kW] (For Service Factor fs=1,0) Pe= NennLeistung [kW] (Bei Betriebsfaktor fs=1,0)						Göv. Rad.Yük Çıkış	Göv.Rad.Yük Giriş	Ağırlık Weight Gewicht [kg]	Ölçü Sayfası Dim. Page Maße Seite	Fiyat Kodu Price Ref. Preis No.
				Giriş devri[d/d] / Input speed[rpm] / Antriebsdrehzahl[upm]						Zul.Querkräfte (Abtrieb)	Zul.Querkräfte (Antrieb)			
				n1=2800	n1=1400	n1=900	n1=750	n1=450	n1=350	Fqam [N] (n1=1400rpm)	Fqem [N] (n1=1400rpm)			
<b>15000</b>	844.51	1.7	<b>KT875</b>	5.8	<b>2.9</b>	1.9	1.6	0.93	0.73	76000	-	640	406	KT026
	957.34	1.5		5.1	<b>2.6</b>	1.7	1.4	0.83	0.64	76000	-			
	1096.71	1.3		4.5	<b>2.2</b>	1.4	1.2	0.72	0.56	76000	-			
	1313.07	1.1		3.8	<b>1.9</b>	1.2	1.0	0.60	0.47	76000	-			
	1495.27	0.94		3.3	<b>1.7</b>	1.1	0.89	0.53	0.41	76000	-			
	1671.18	0.84		3.0	<b>1.5</b>	0.95	0.79	0.48	0.37	76000	-			
	1891.08	0.74		2.6	<b>1.3</b>	0.84	0.70	0.42	0.33	76000	-			
<b>15000</b>	2074.42	0.67	<b>KT876</b>	2.4	<b>1.2</b>	0.78	0.65	0.39	0.30	76000	1922	650	406	KT027
	2387.89	0.59		2.1	<b>1.1</b>	0.68	0.57	0.34	0.26	76000	1939			
	2665.68	0.53		1.9	<b>0.95</b>	0.61	0.51	0.30	0.26	76000	1951			
	2996.39	0.47		1.7	<b>0.84</b>	0.54	0.45	0.27	0.23	76000	1962			
	3396.71	0.41		1.5	<b>0.74</b>	0.48	0.40	0.27	0.21	76000	1973			
	3891.23	0.36		1.3	<b>0.65</b>	0.42	0.35	0.23	0.18	76000	1983			
	4299.81	0.33		1.2	<b>0.59</b>	0.38	0.32	0.21	0.16	76000	1986			
	5018.35	0.28		1.0	<b>0.51</b>	0.32	0.27	0.18	0.14	76000	1990			
	5902.70	0.24		0.86	<b>0.43</b>	0.28	0.26	0.15	0.12	76000	1994			
	7017.76	0.20		0.73	<b>0.36</b>	0.26	0.22	0.13	0.10	76000	1998			
	7938.12	0.18		0.64	<b>0.32</b>	0.23	0.19	0.11	0.09	76000	2000			
	9052.24	0.15		0.56	<b>0.28</b>	0.20	0.17	0.10	0.08	76000	2002			
	11245.67	0.12		0.50	<b>0.25</b>	0.18	0.15	0.09	0.07	76000	2005			
	12789.19	0.11		0.44	<b>0.22</b>	0.16	0.13	0.08	0.06	76000	2006			





# Ölçü Sayfaları

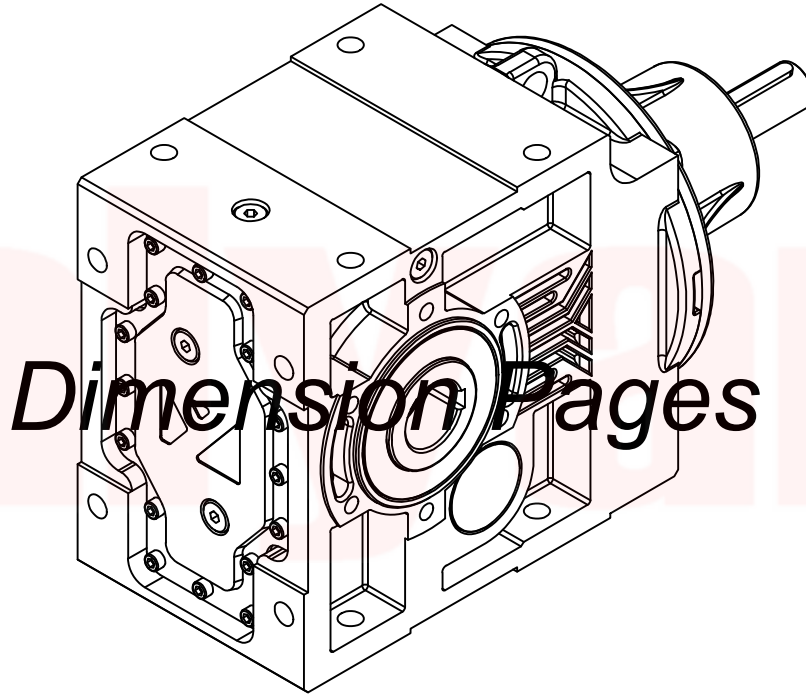

Abmessungsseiten



# Ölçü Sayfaları Dimension Pages Abmessungenseiten



-Mil ucu çekirme deliği DIN 332 sayfa 2 / Tapped center hole to DIN 332, sheet 2 / Zentrierung mit gewinde DIN 332, Blatt 2

KT273.00

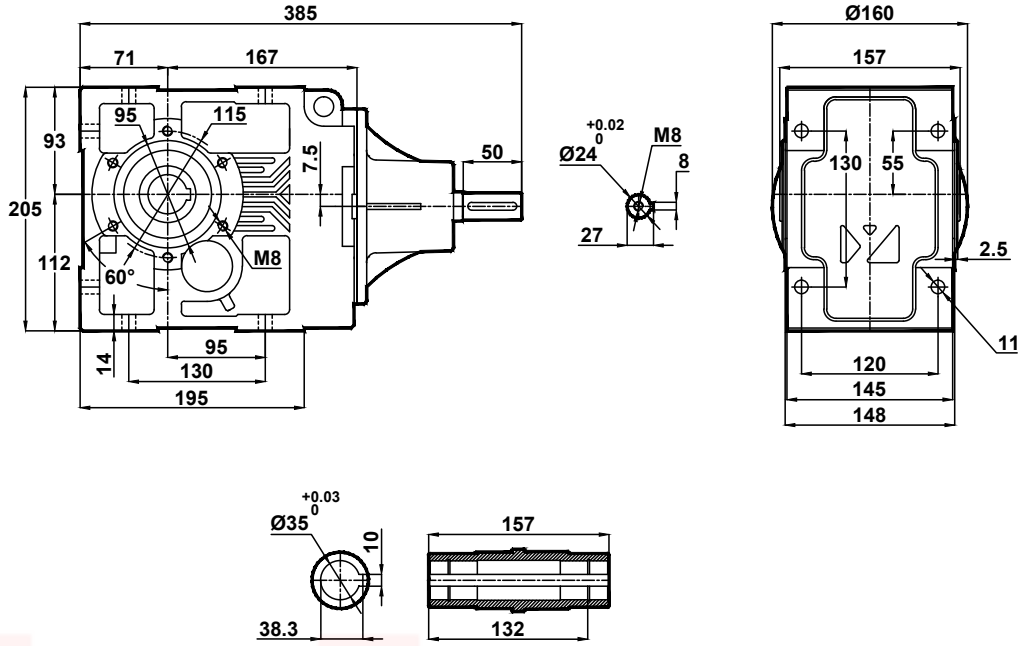

KT273.01

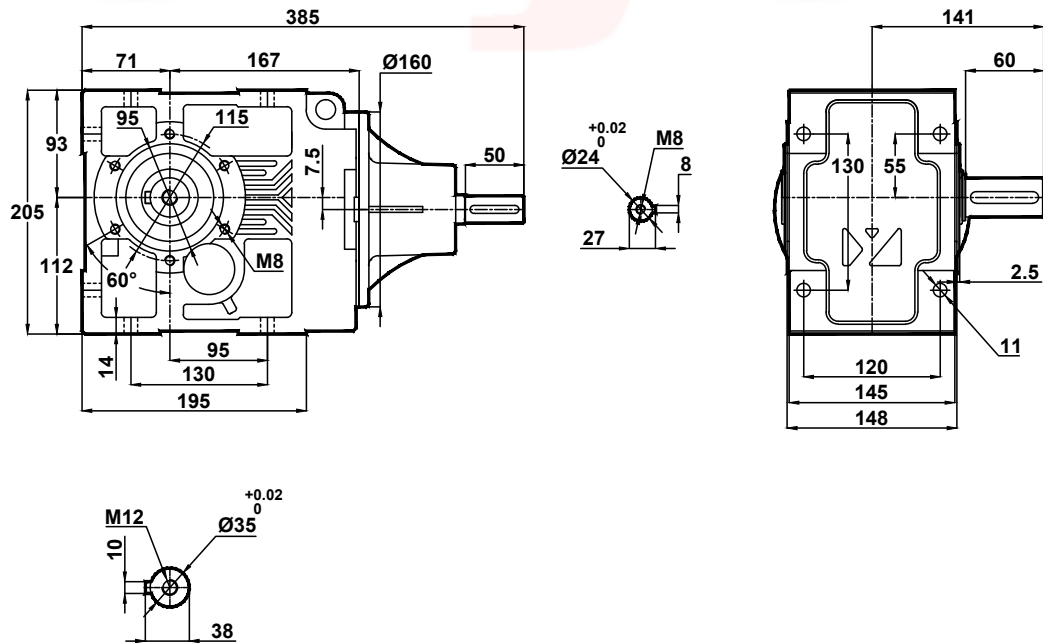



# Ölçü Sayfaları Dimension Pages Abmessungsseiten



-Mil ucu çekirme deliği DIN 332 sayfa 2 / Tapped center hole to DIN 332, sheet 2 / Zentrierung mit gewinde DIN 332, Blatt 2

KT273.02

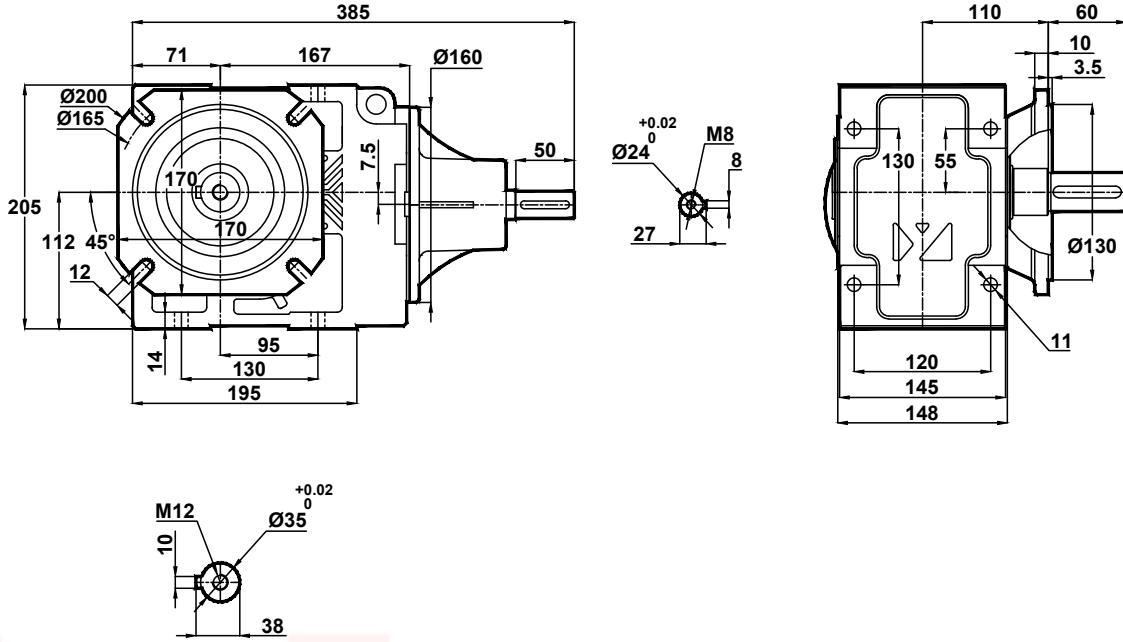

KT273.03

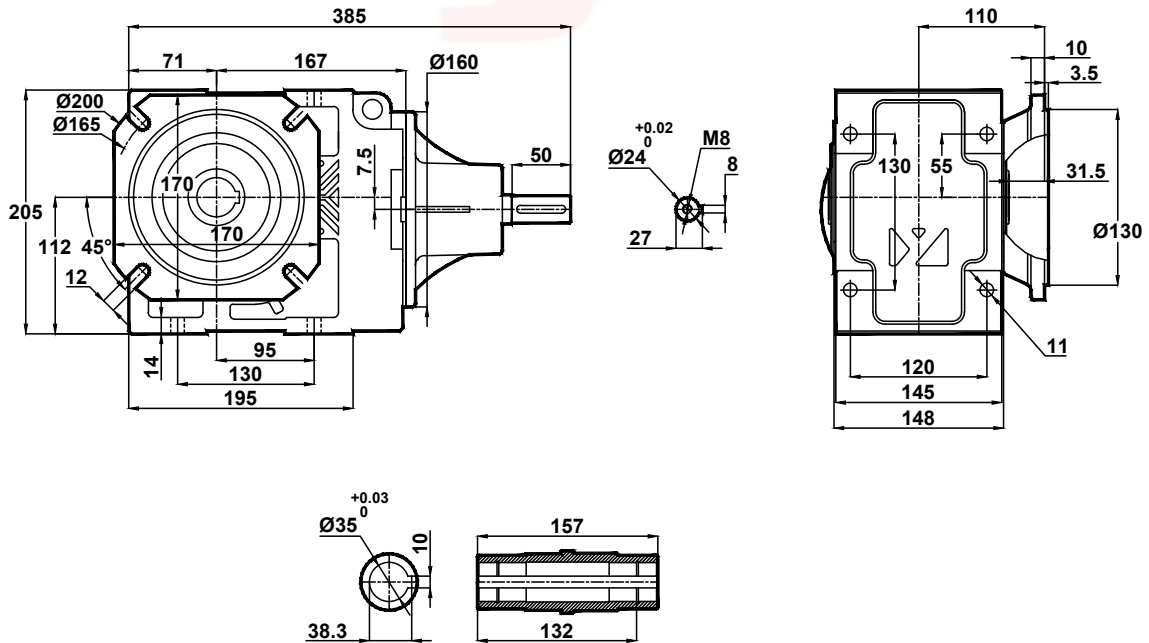



# Ölçü Sayfaları

## Dimension Pages

### Abmessungsseiten



-Mil ucu çektirme deliği DIN 332 sayfa 2 / Tapped center hole to DIN 332, sheet 2 / Zentrierung mit gewinde DIN 332, Blatt 2

KT273.04

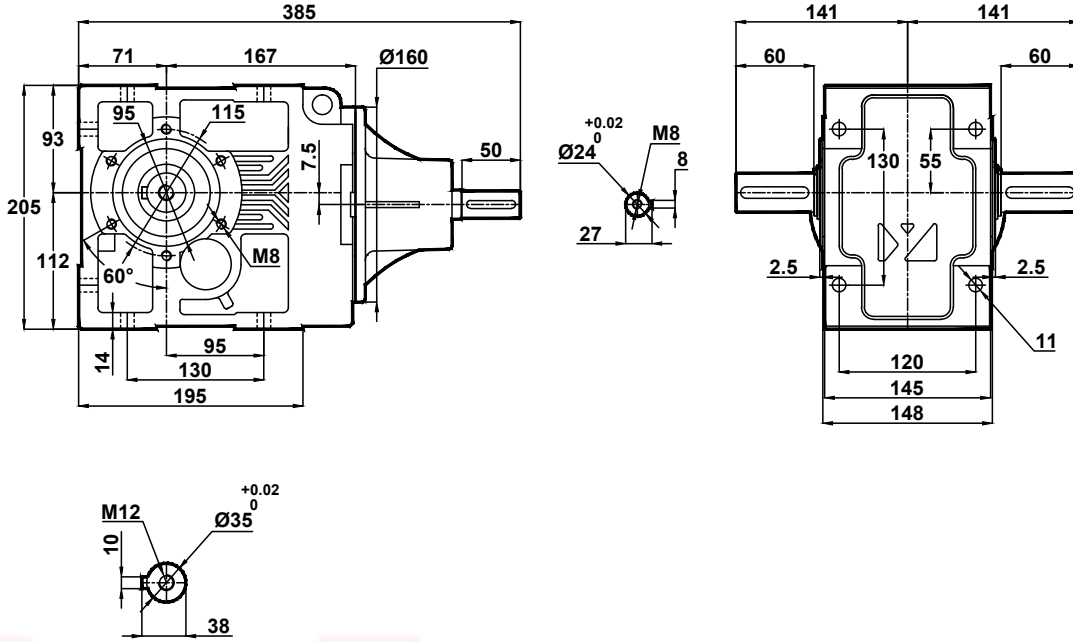

KT273.05

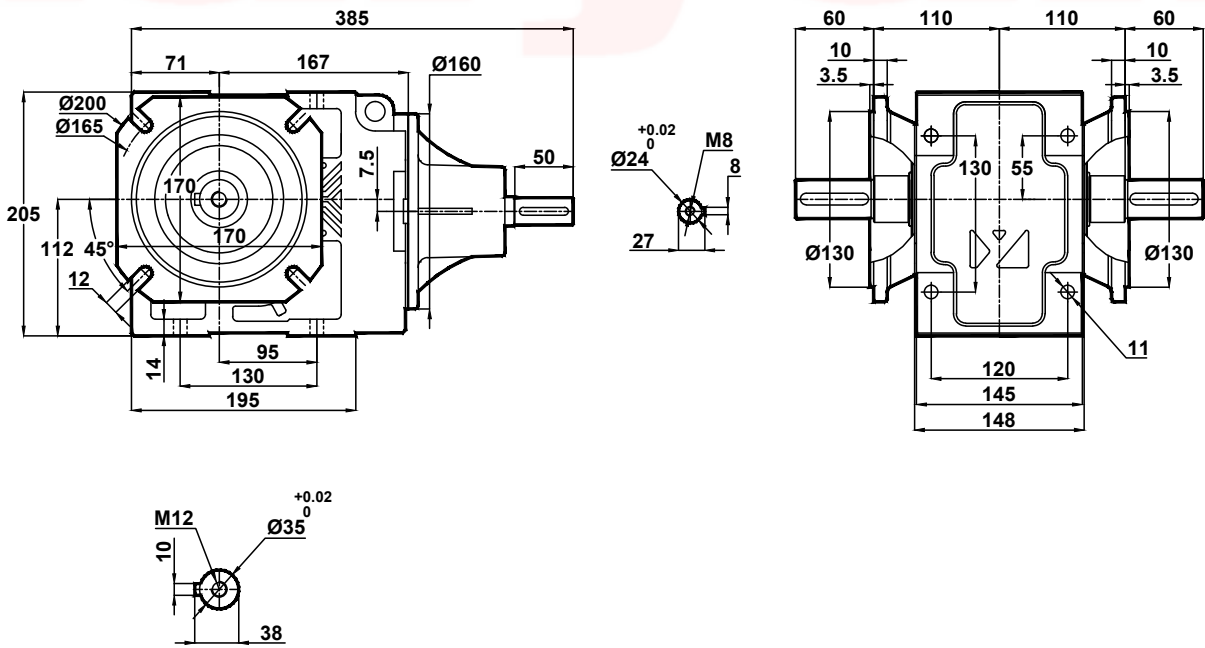



# Ölçü Sayfaları Dimension Pages Abmessungenseiten



-Mil ucu çekirme deliği DIN 332 sayfa 2 / Tapped center hole to DIN 332, sheet 2 / Zentrierung mit gewinde DIN 332, Blatt 2

KT273.08

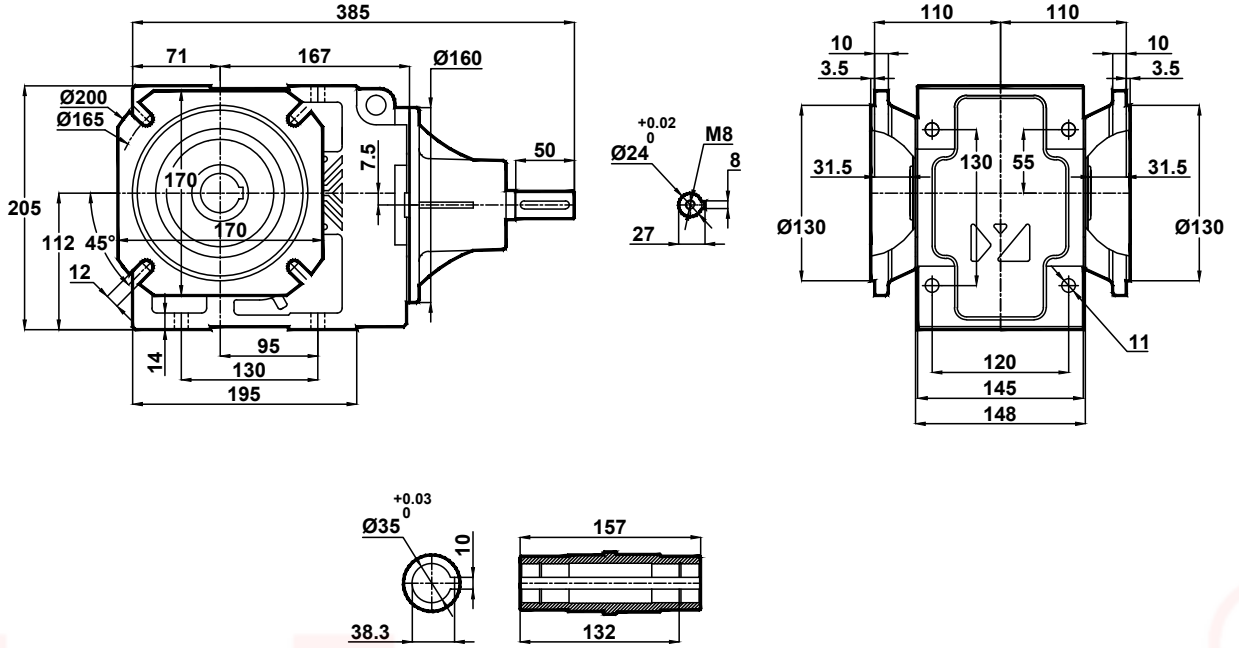



# Ölçü Sayfaları Dimension Pages Abmessungenseiten



-Mil ucu çekirme deliği DIN 332 sayfa 2 / Tapped center hole to DIN 332, sheet 2 / Zentrierung mit gewinde DIN 332, Blatt 2

KT275.00  
KT276.00

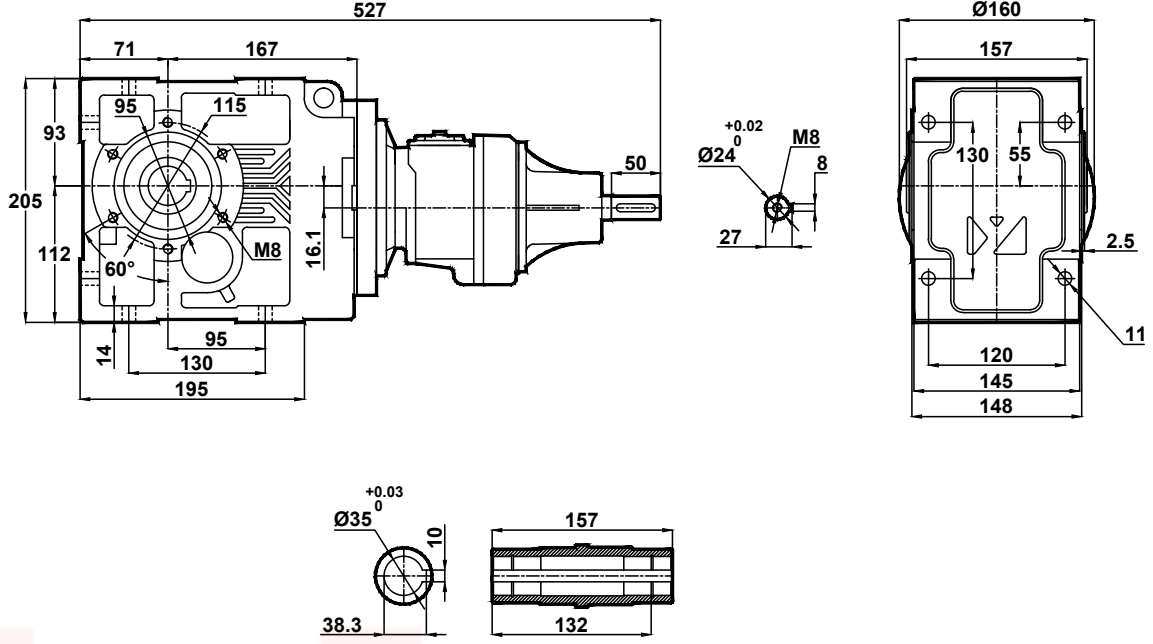

KT275.01  
KT276.01

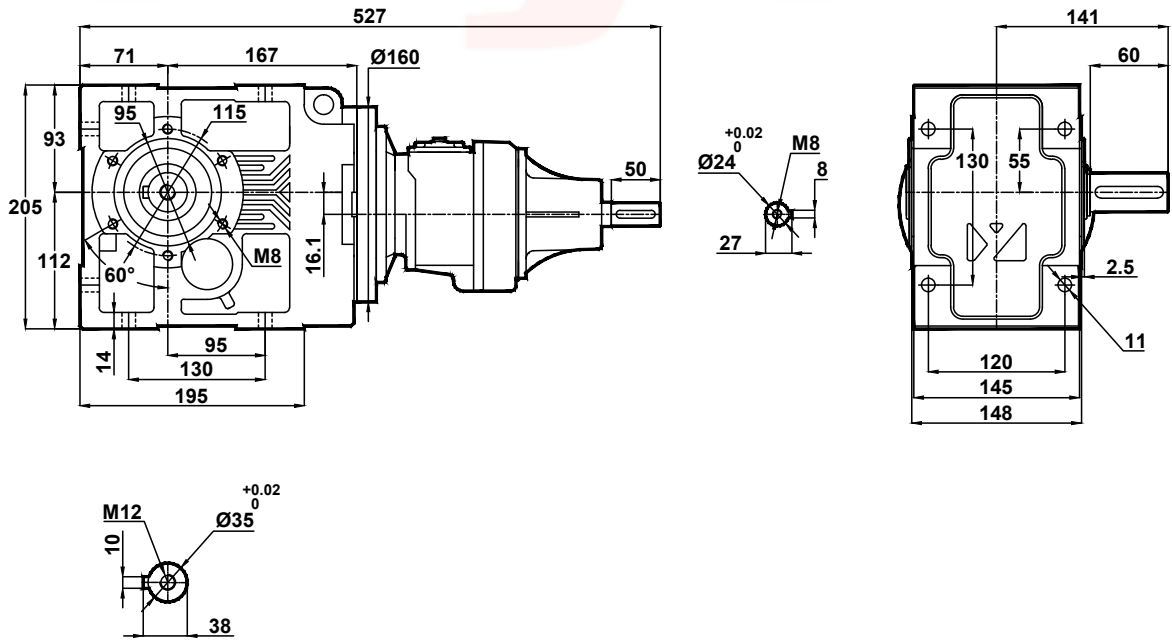



# Ölçü Sayfaları

## Dimension Pages

### Abmessungsseiten



-Mil ucu çekirme deliği DIN 332 sayfa 2 / Tapped center hole to DIN 332, sheet 2 / Zentrierung mit gewinde DIN 332, Blatt 2

KT275.02  
KT276.02

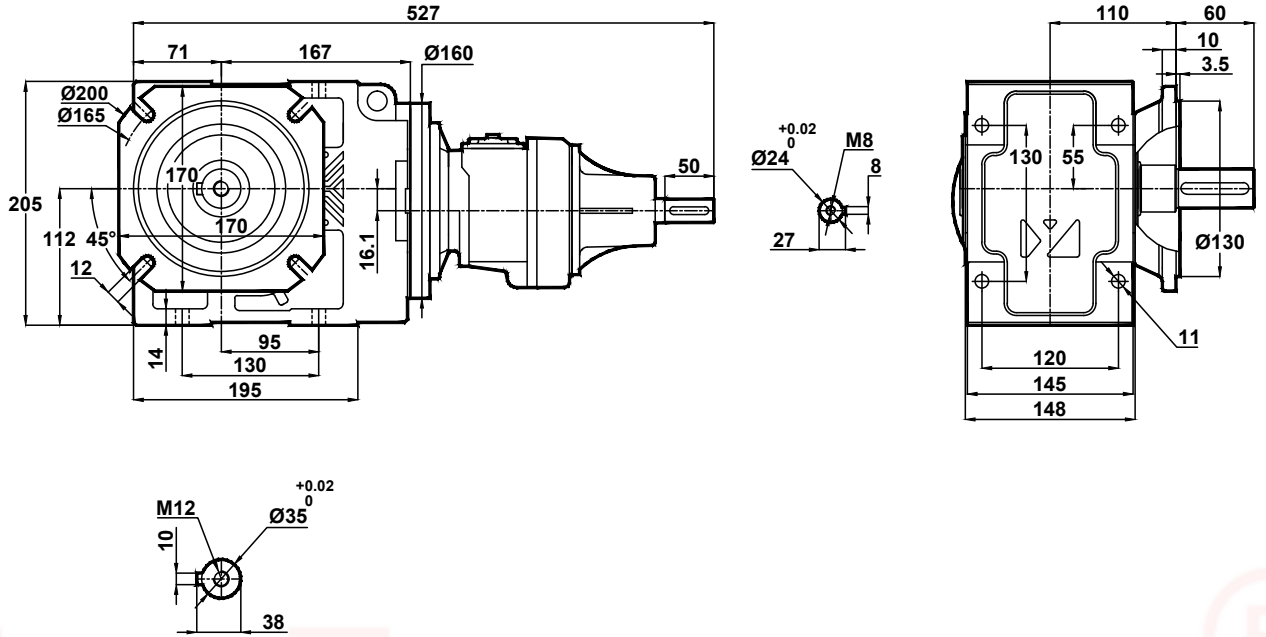

KT275.03  
KT276.03

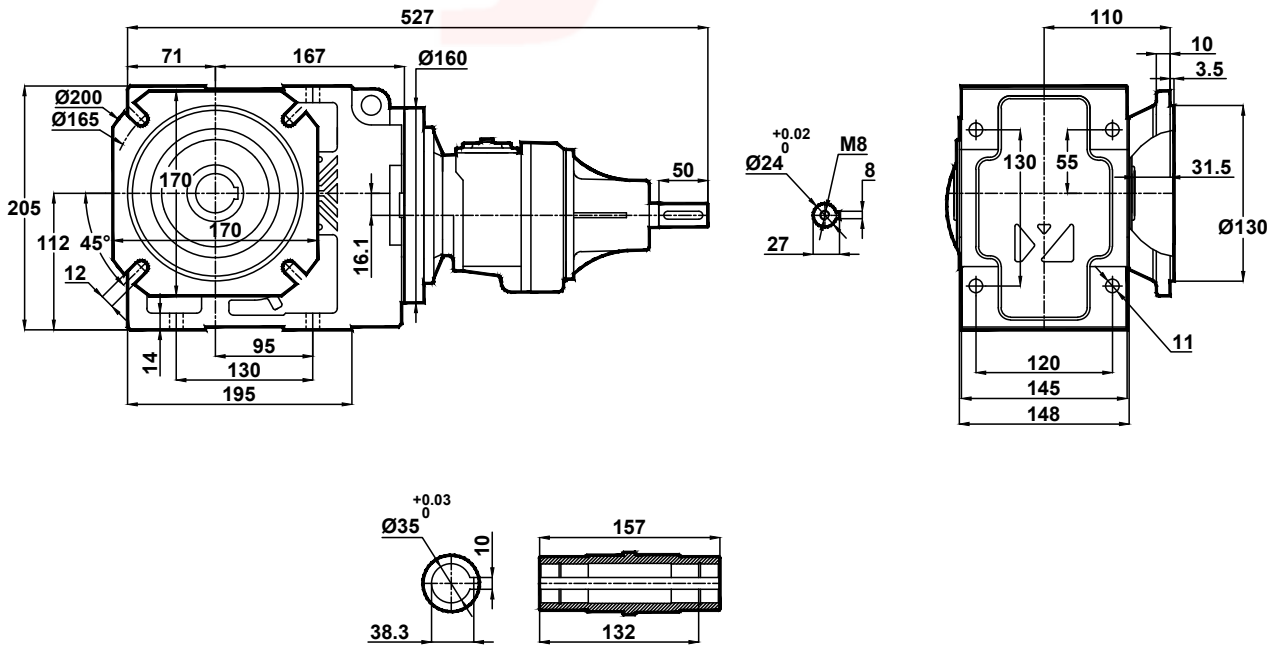



# Ölçü Sayfaları Dimension Pages Abmessungsseiten



-Mil ucu çekirme deliği DIN 332 sayfa 2 / Tapped center hole to DIN 332, sheet 2 / Zentrierung mit gewinde DIN 332, Blatt 2

KT275.04  
KT276.04

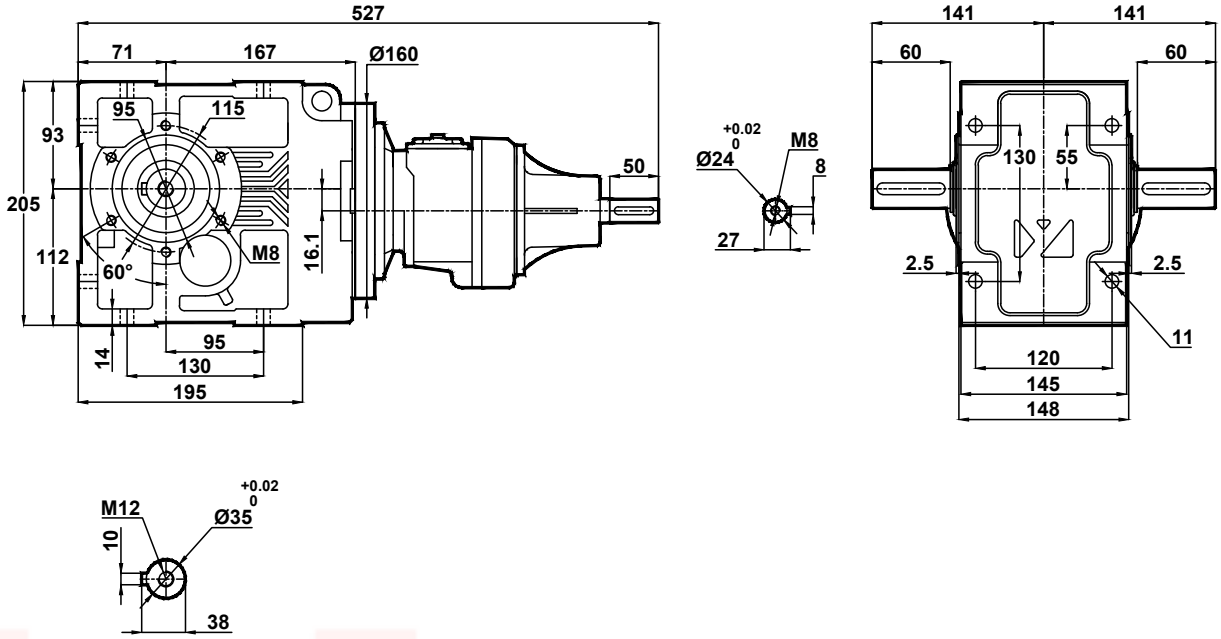

KT275.05  
KT276.05

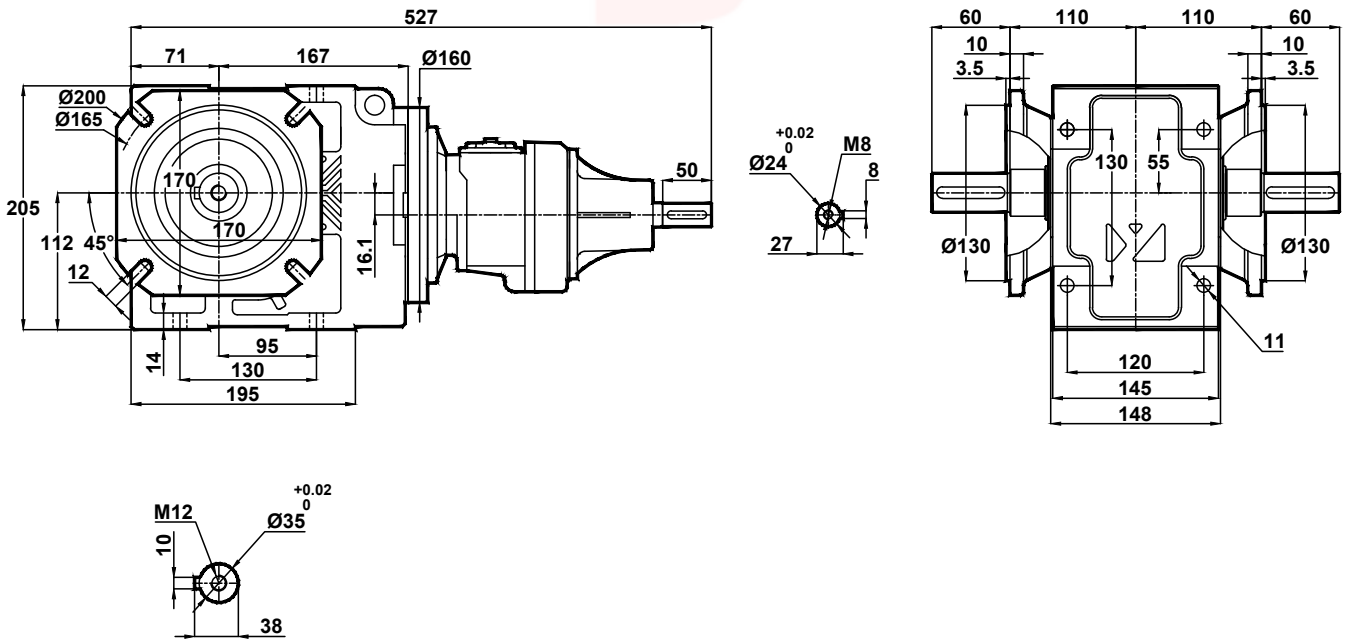





# Ölçü Sayfaları Dimension Pages Abmessungenseiten



-Mil ucu çekirme deliği DIN 332 sayfa 2 / Tapped center hole to DIN 332, sheet 2 / Zentrierung mit gewinde DIN 332, Blatt 2

KT275.08  
KT276.08

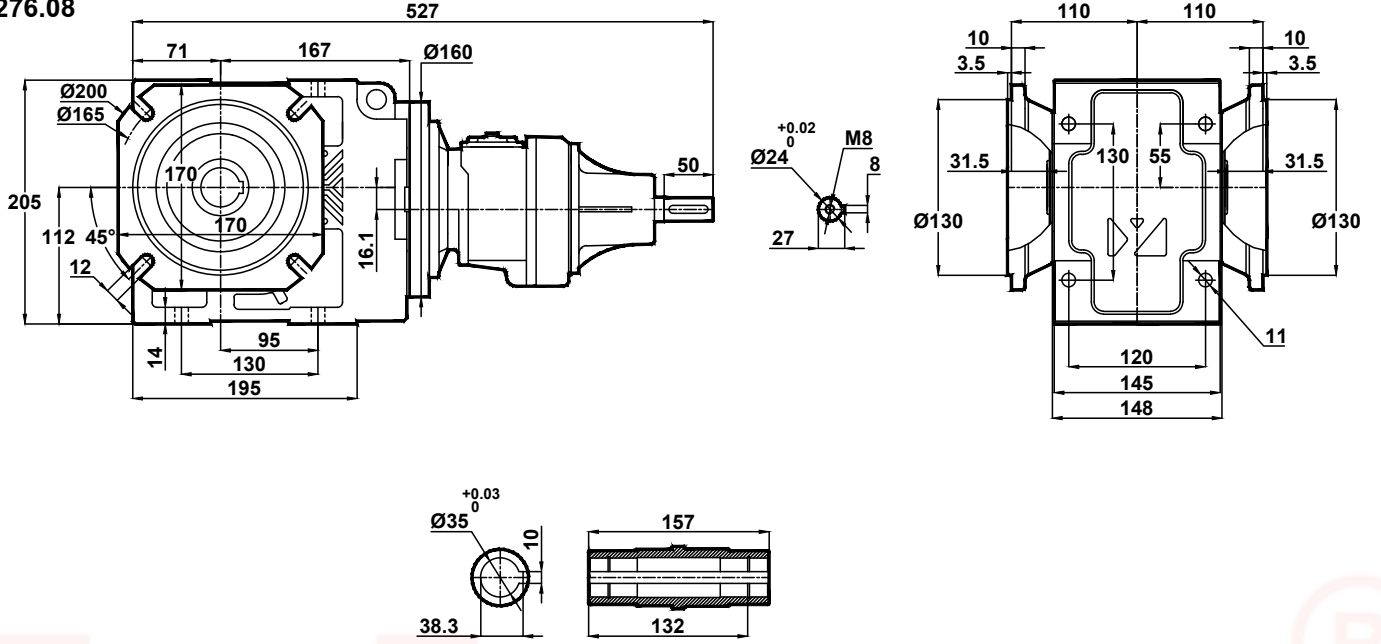



# Ölçü Sayfaları Dimension Pages Abmessungenseiten



-Mil ucu çekirme deliği DIN 332 sayfa 2 / Tapped center hole to DIN 332, sheet 2 / Zentrierung mit gewinde DIN 332, Blatt 2

KT373.00

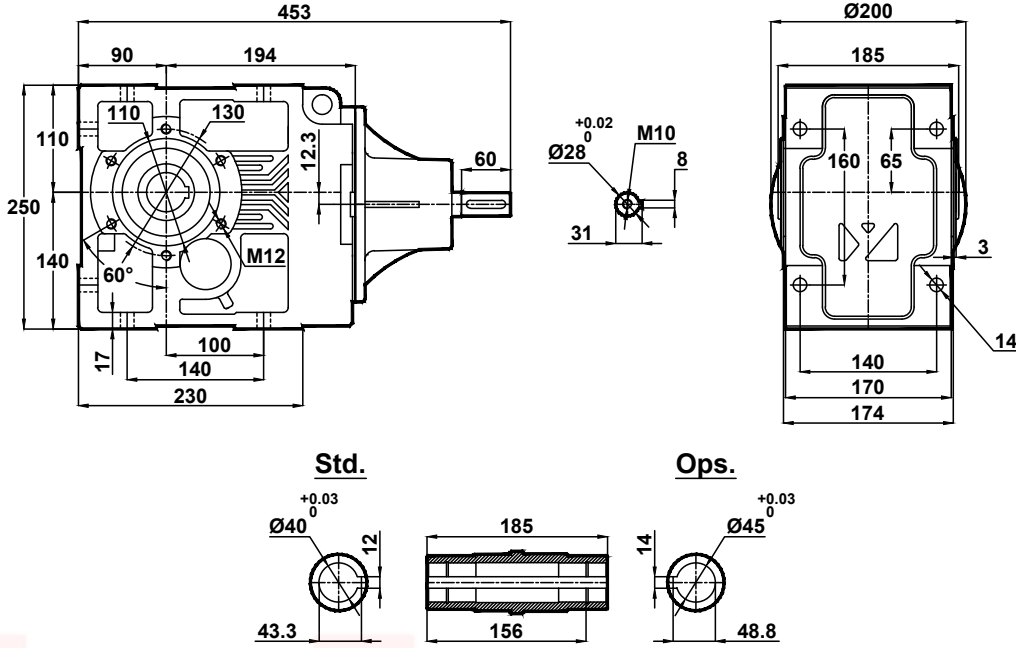

KT373.01

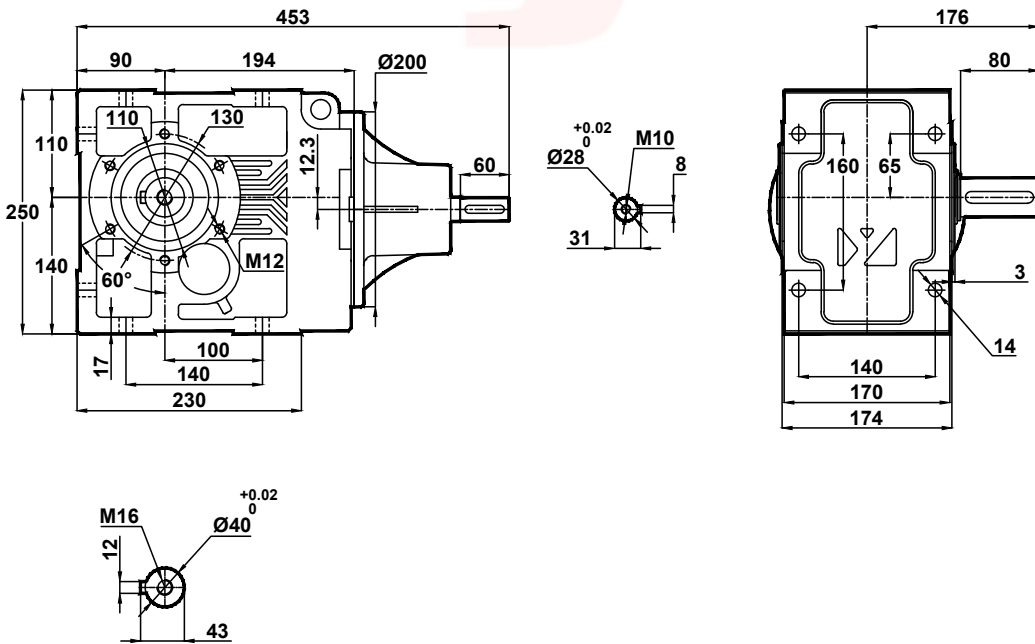



# Ölçü Sayfaları Dimension Pages Abmessungenseiten



-Mil ucu çekirme deliği DIN 332 sayfa 2 / Tapped center hole to DIN 332, sheet 2 / Zentrierung mit gewinde DIN 332, Blatt 2

KT373.02

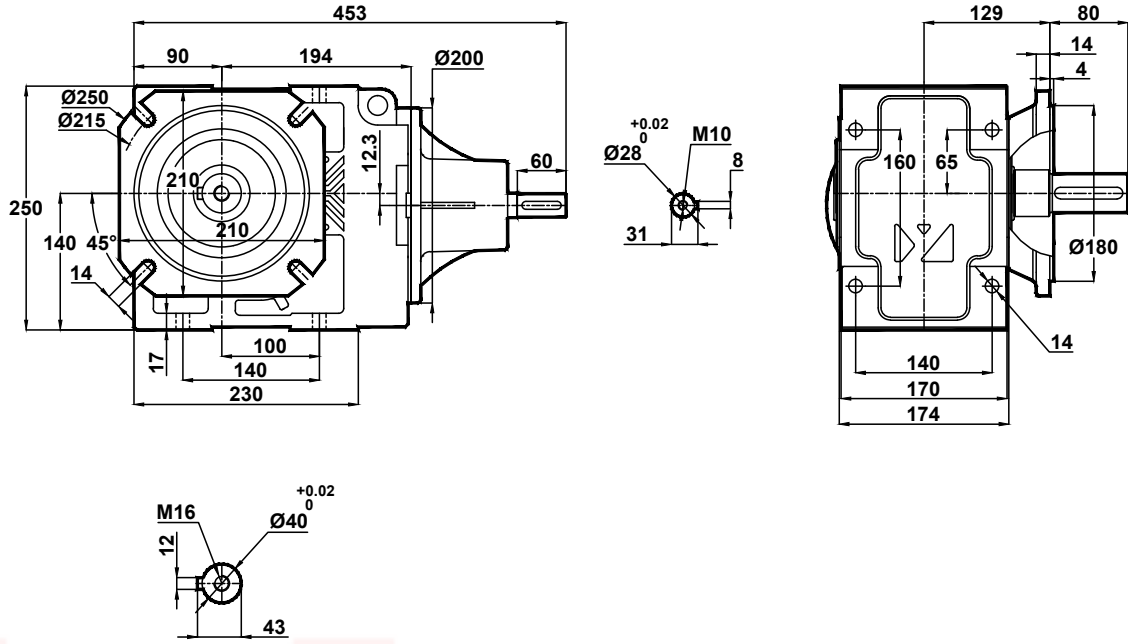

KT373.03

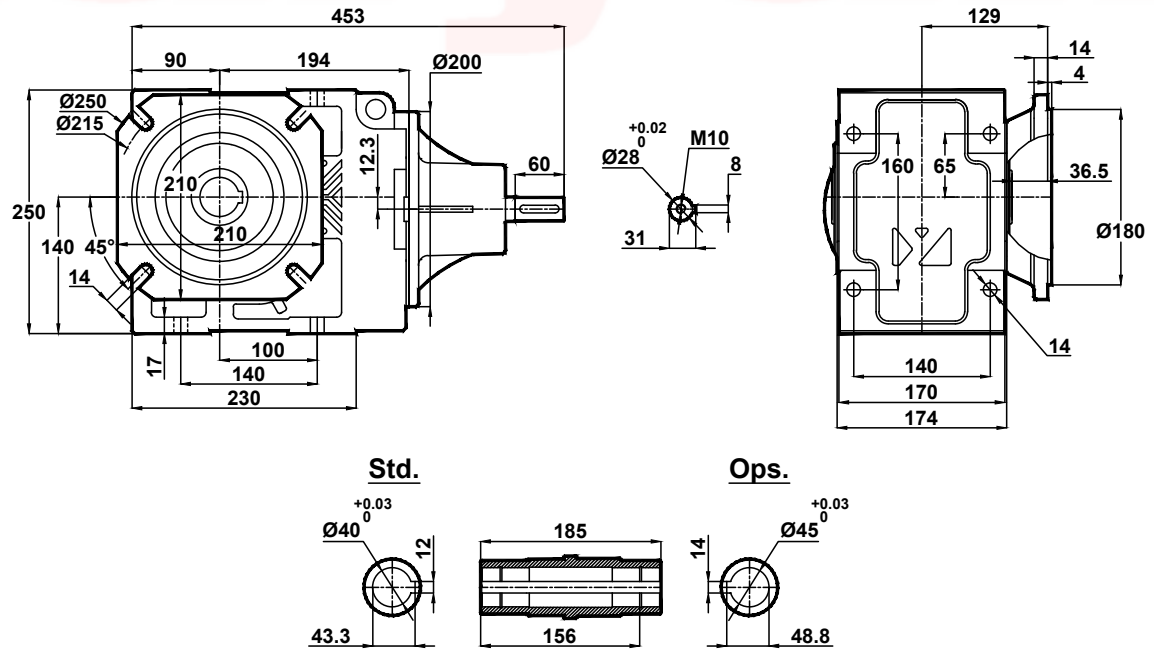

Std.

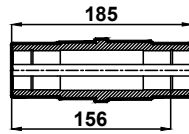
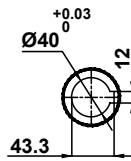

Ops.

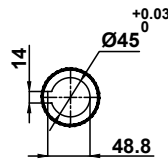



# Ölçü Sayfaları Dimension Pages Abmessungenseiten



-Mil ucu çektirme deliği DIN 332 sayfa 2 / Tapped center hole to DIN 332, sheet 2 / Zentrierung mit gewinde DIN 332, Blatt 2

## KT373.04

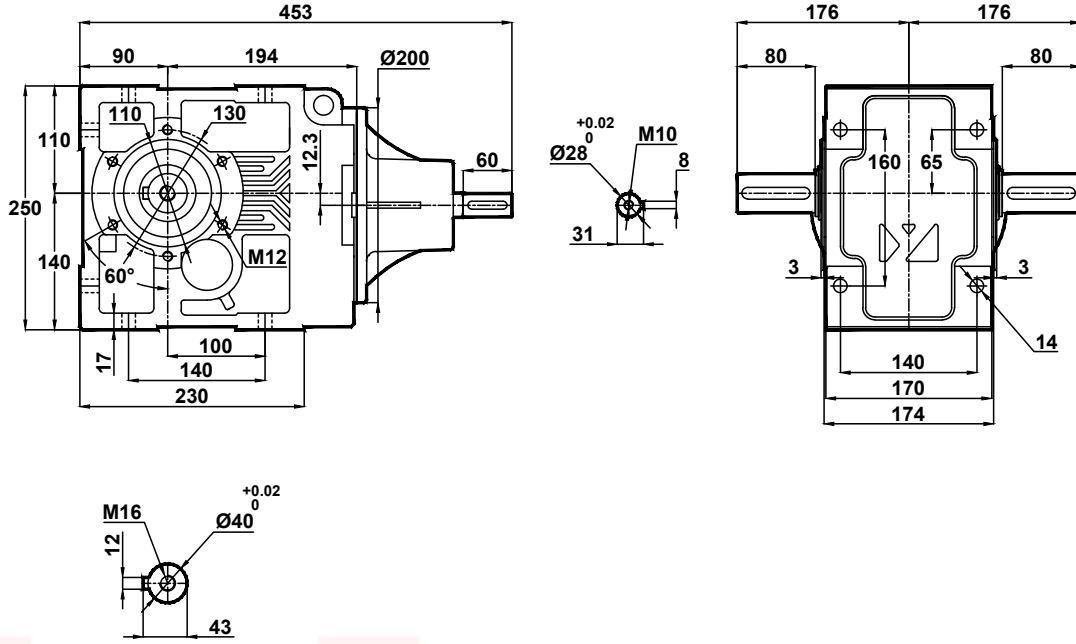

## KT373.05

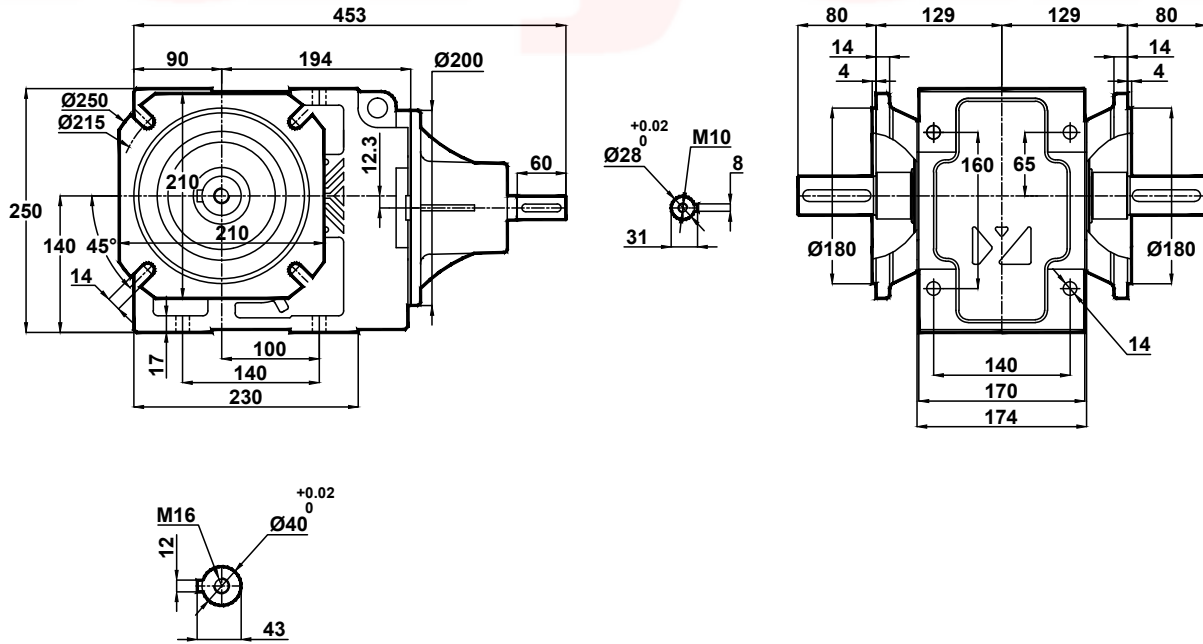



# Ölçü Sayfaları Dimension Pages Abmessungsseiten



-Mil ucu çekirme deliği DIN 332 sayfa 2 / Tapped center hole to DIN 332, sheet 2 / Zentrierung mit gewinde DIN 332, Blatt 2

KT373.08

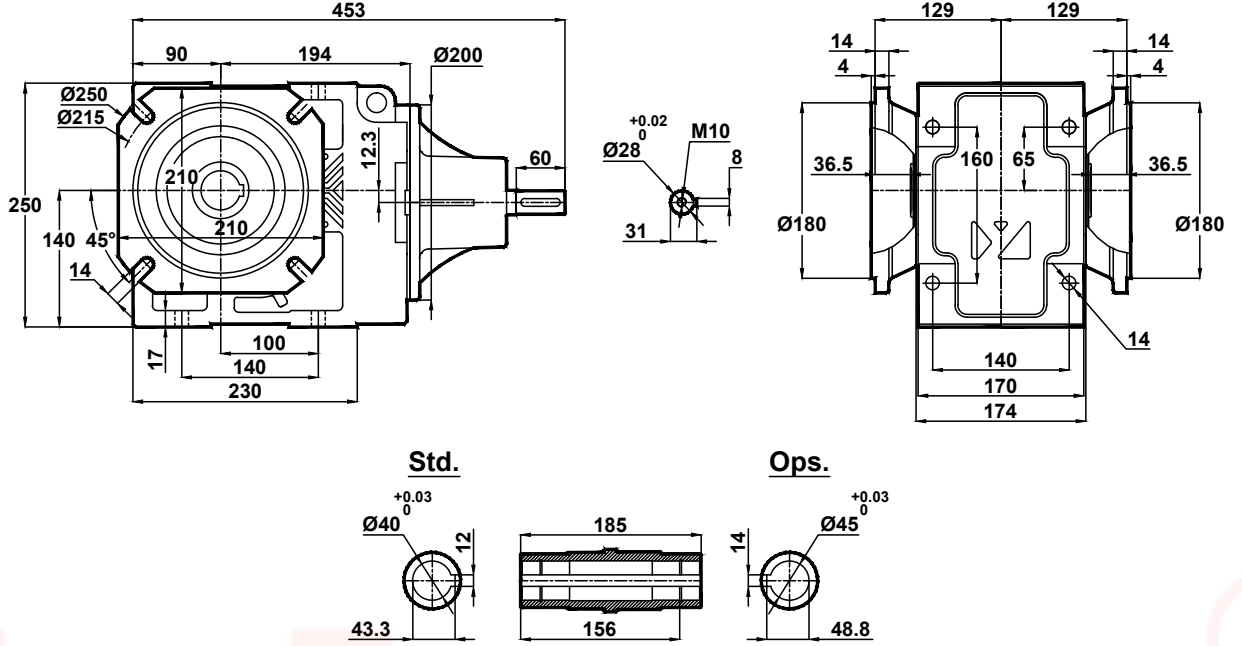



# Ölçü Sayfaları Dimension Pages Abmessungenseiten



-Mil ucu çekirme deliği DIN 332 sayfa 2 / Tapped center hole to DIN 332, sheet 2 / Zentrierung mit gewinde DIN 332, Blatt 2

KT374.00

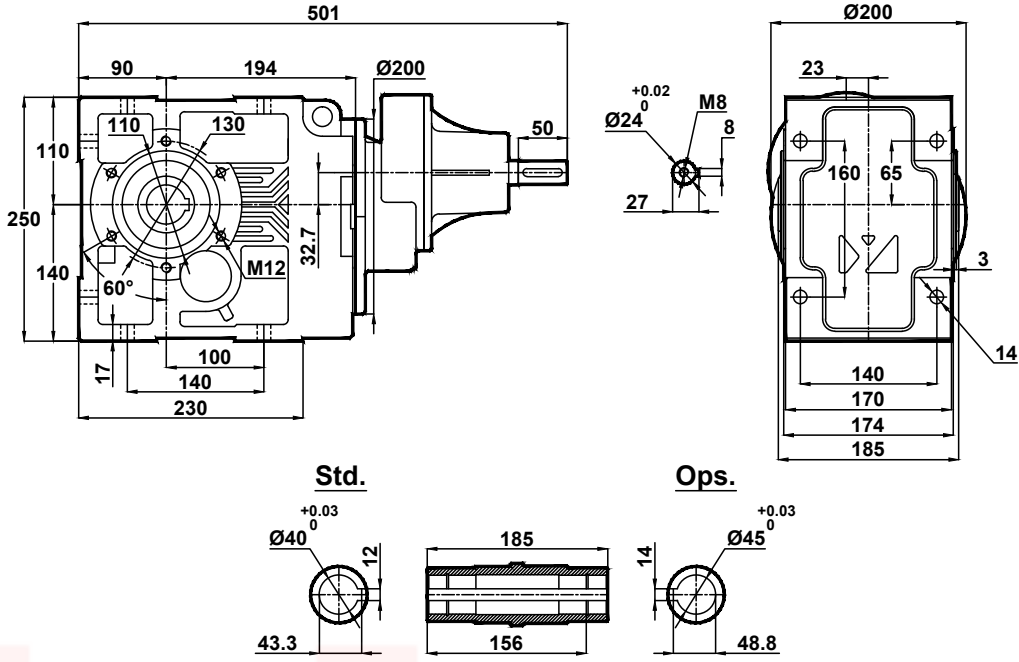

KT374.01

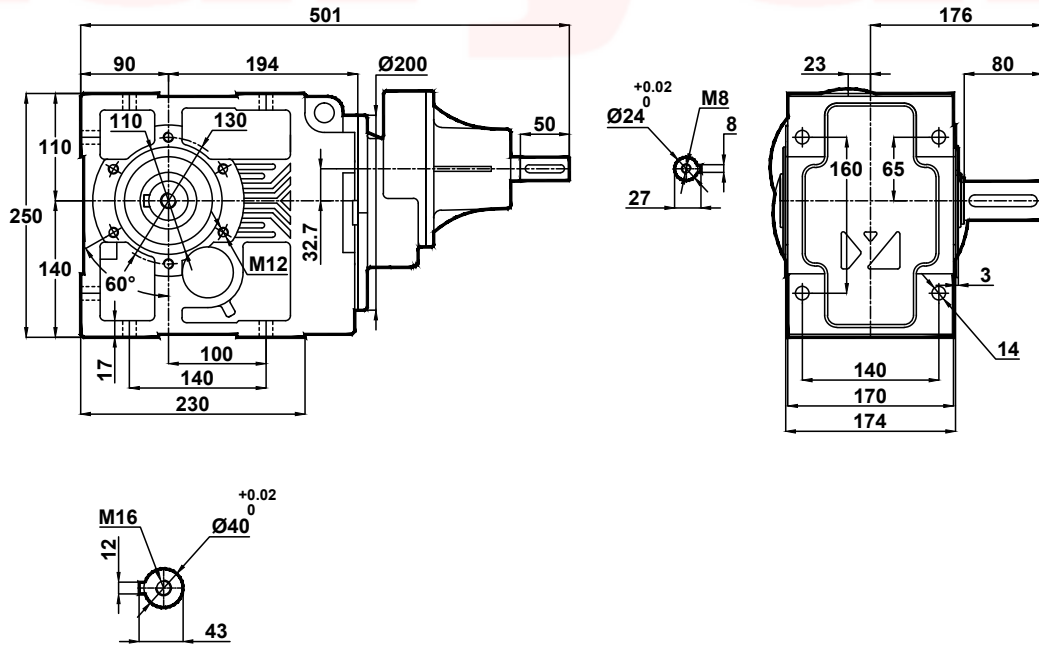



# Ölçü Sayfaları Dimension Pages Abmessungenseiten



-Mil ucu çekirme deliği DIN 332 sayfa 2 / Tapped center hole to DIN 332, sheet 2 / Zentrierung mit gewinde DIN 332, Blatt 2

KT374.02

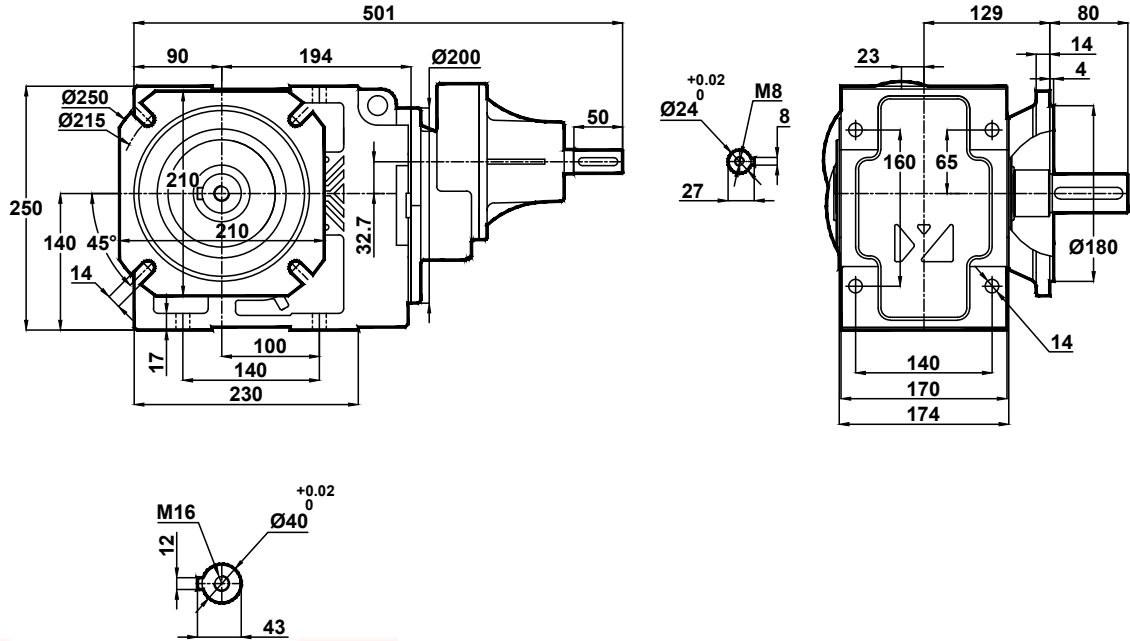

KT374.03

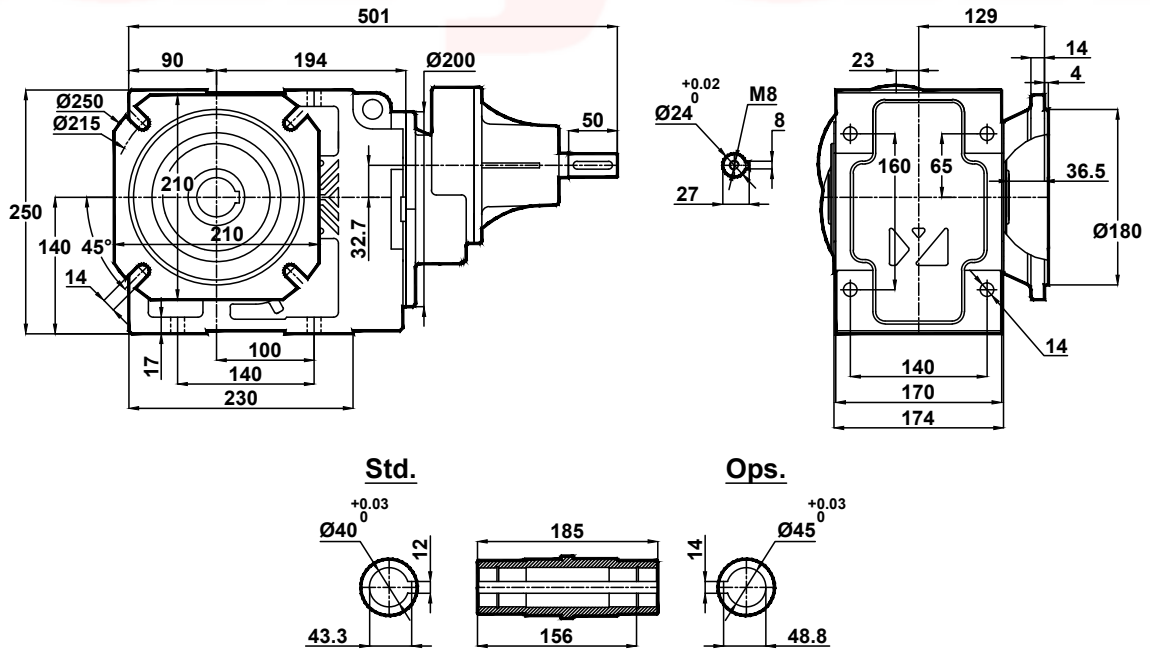



# Ölçü Sayfaları Dimension Pages Abmessungenseiten



-Mil ucu çektirme deliği DIN 332 sayfa 2 / Tapped center hole to DIN 332, sheet 2 / Zentrierung mit gewinde DIN 332, Blatt 2

## KT374.04

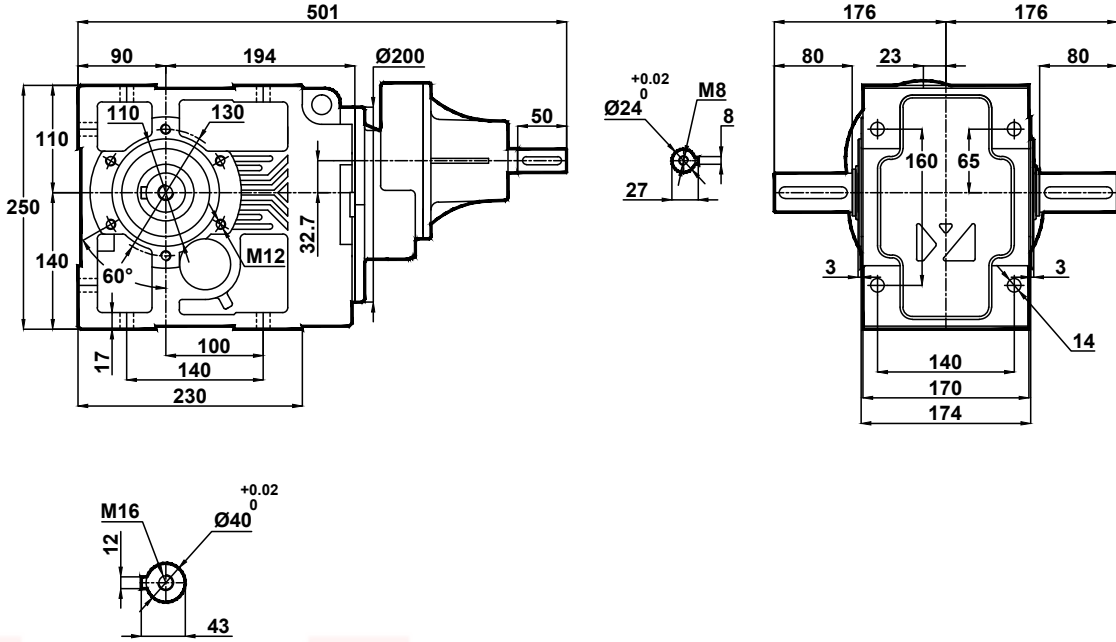

## KT374.05

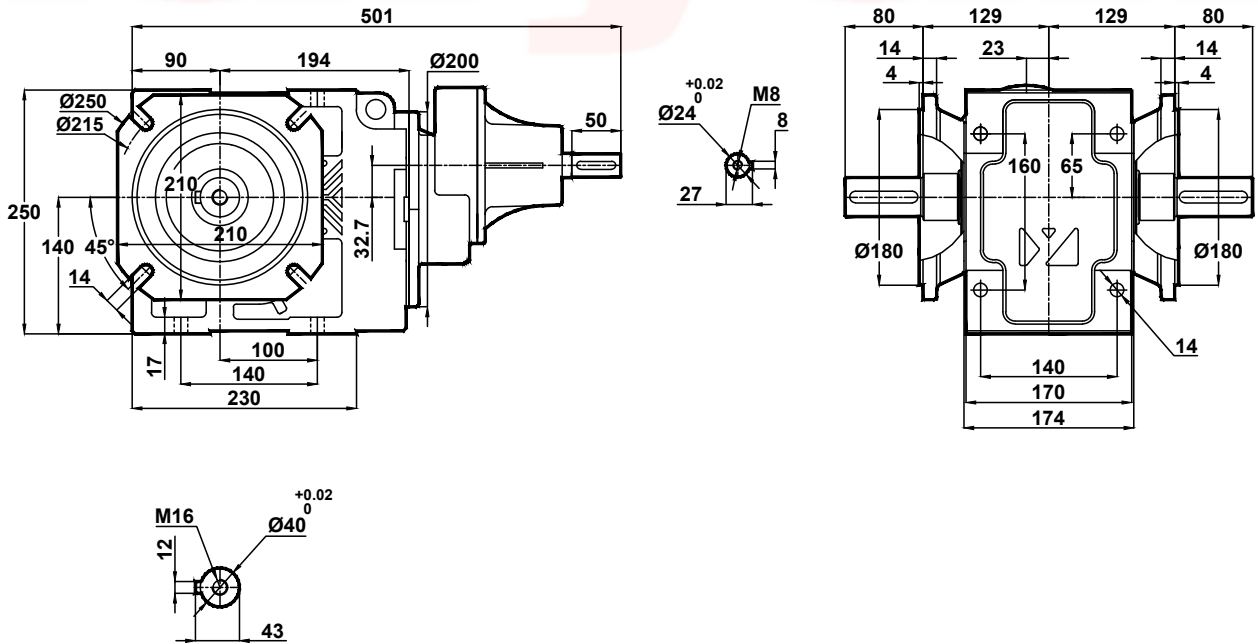





# Ölçü Sayfaları

## Dimension Pages

### Abmessungsseiten



-Mil ucu çekirme deliği DIN 332 sayfa 2 / Tapped center hole to DIN 332, sheet 2 / Zentrierung mit gewinde DIN 332, Blatt 2

KT374.08

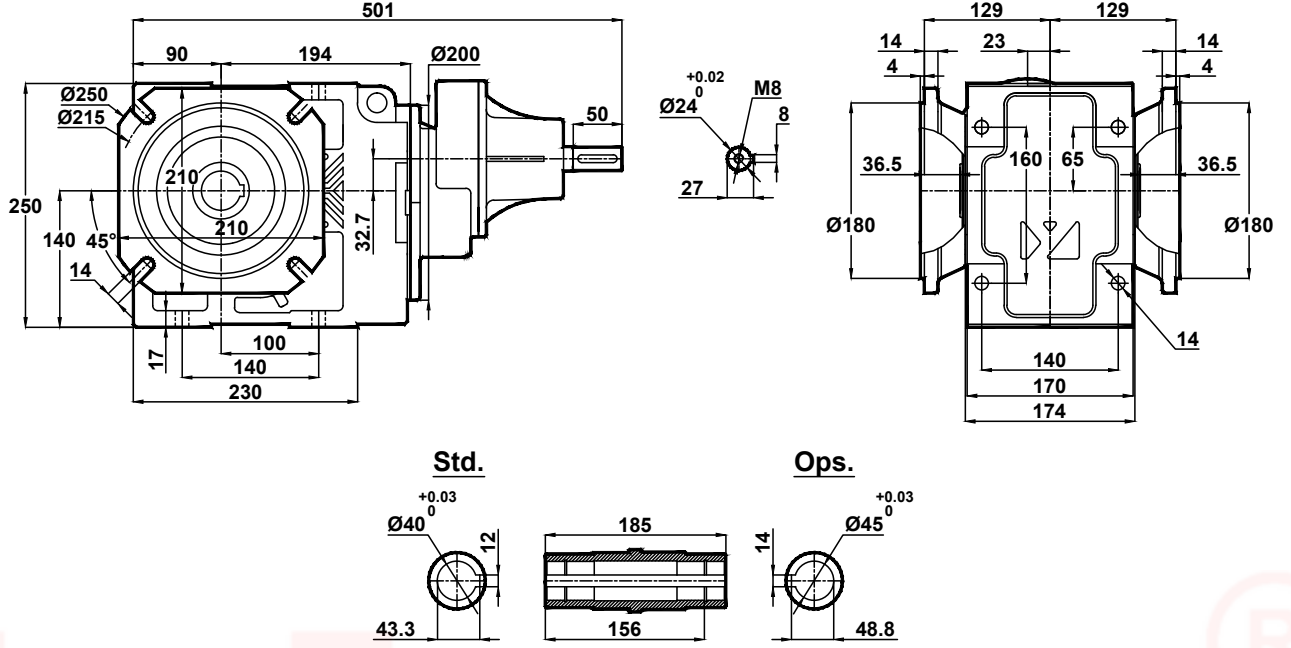



# Ölçü Sayfaları Dimension Pages Abmessungenseiten



-Mil ucu çekirme deliği DIN 332 sayfa 2 / Tapped center hole to DIN 332, sheet 2 / Zentrierung mit gewinde DIN 332, Blatt 2

KT375.00  
KT376.00

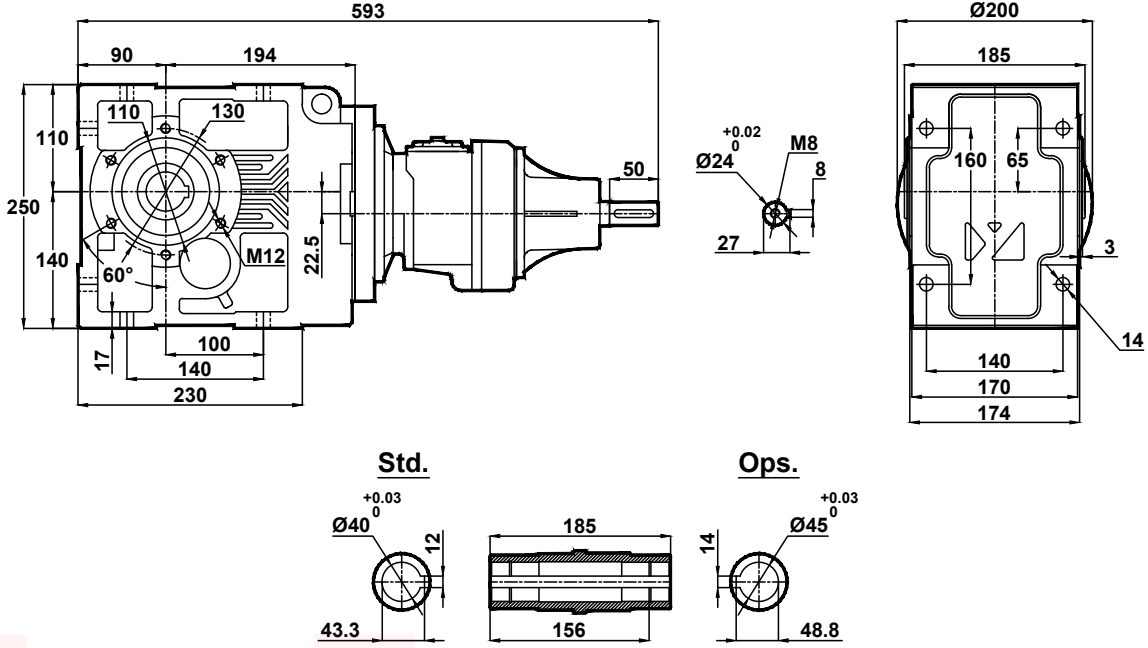

KT375.01  
KT376.01

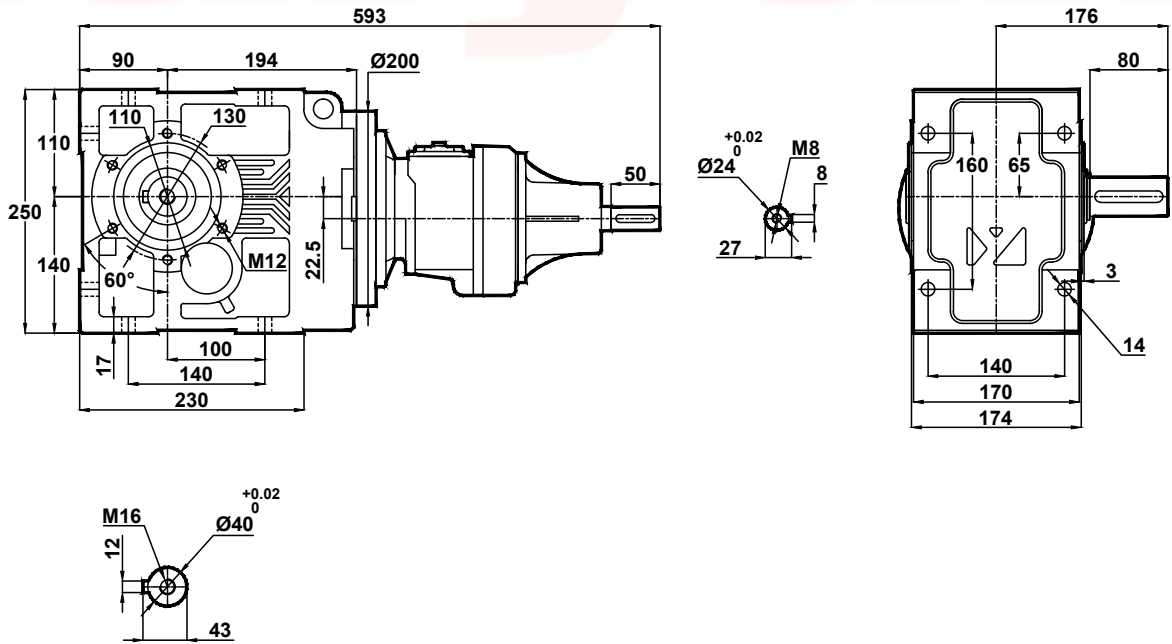



# Ölçü Sayfaları Dimension Pages Abmessungsseiten



-Mil ucu çekirme deliği DIN 332 sayfa 2 / Tapped center hole to DIN 332, sheet 2 / Zentrierung mit gewinde DIN 332, Blatt 2

KT375.02  
KT376.02

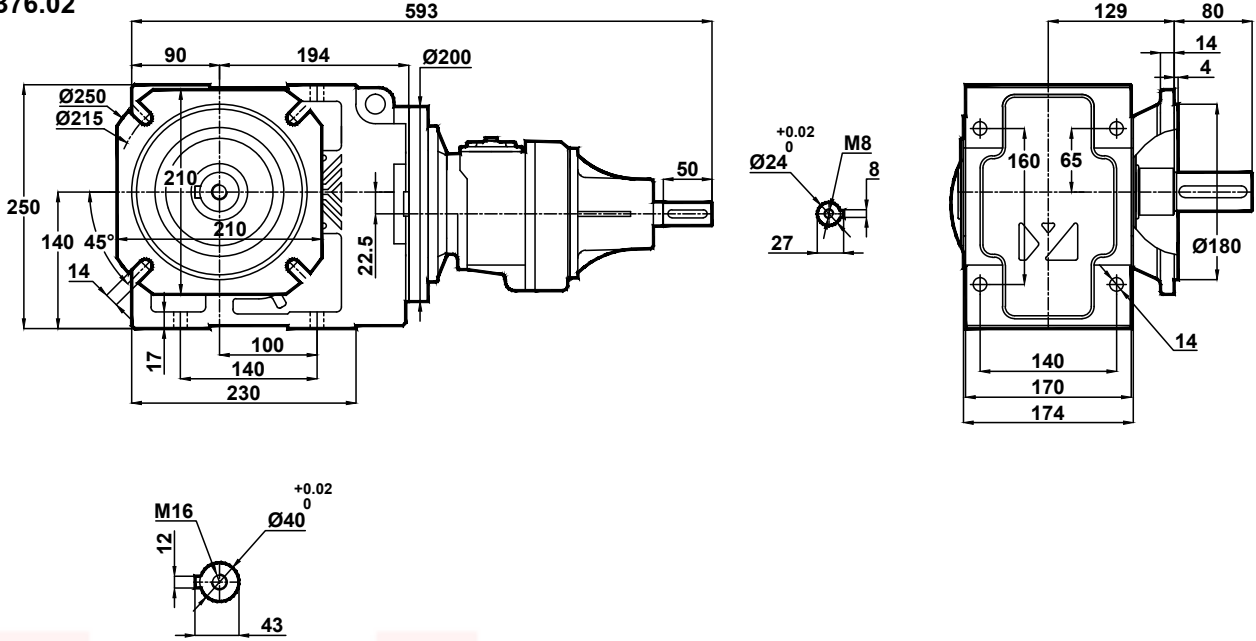

KT375.03  
KT376.03

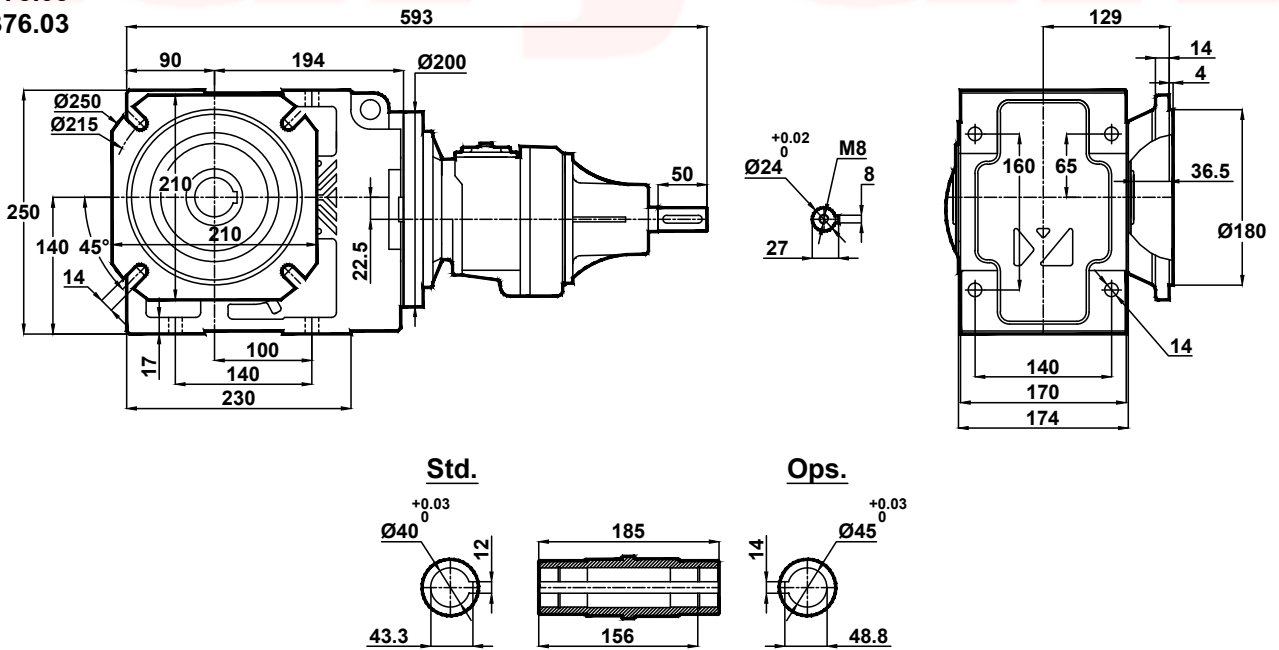



# Ölçü Sayfaları Dimension Pages Abmessungsseiten



-Mil ucu çektirme deliği DIN 332 sayfa 2 / Tapped center hole to DIN 332, sheet 2 / Zentrierung mit gewinde DIN 332, Blatt 2

KT375.04  
KT376.04

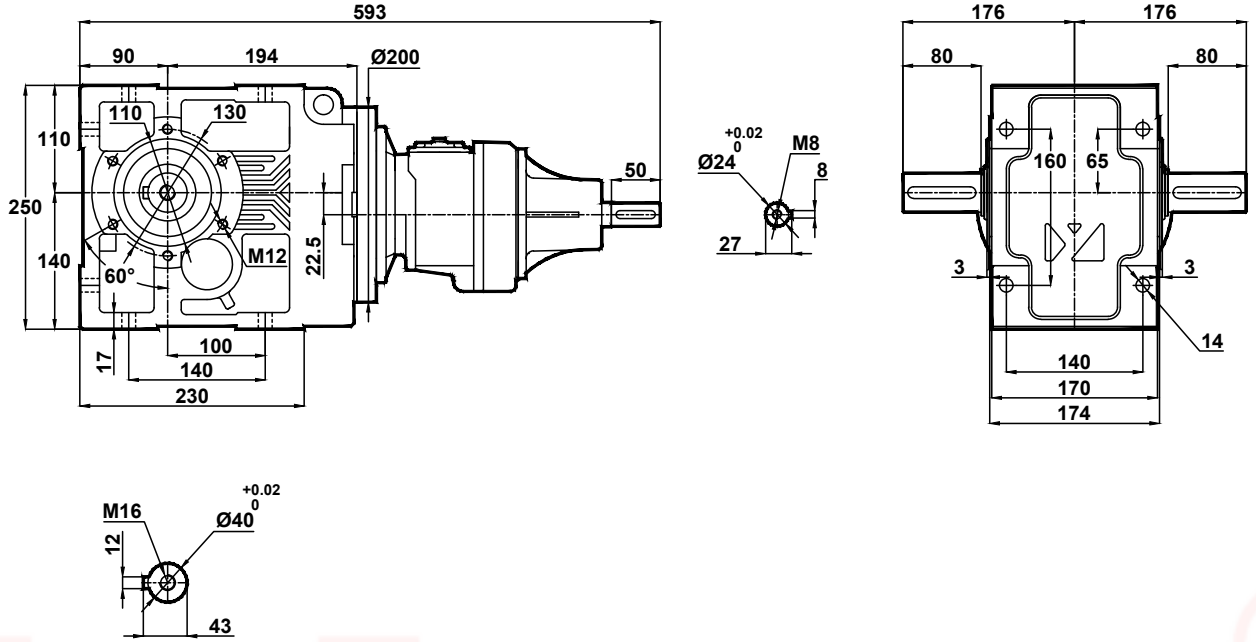

KT375.05  
KT376.05

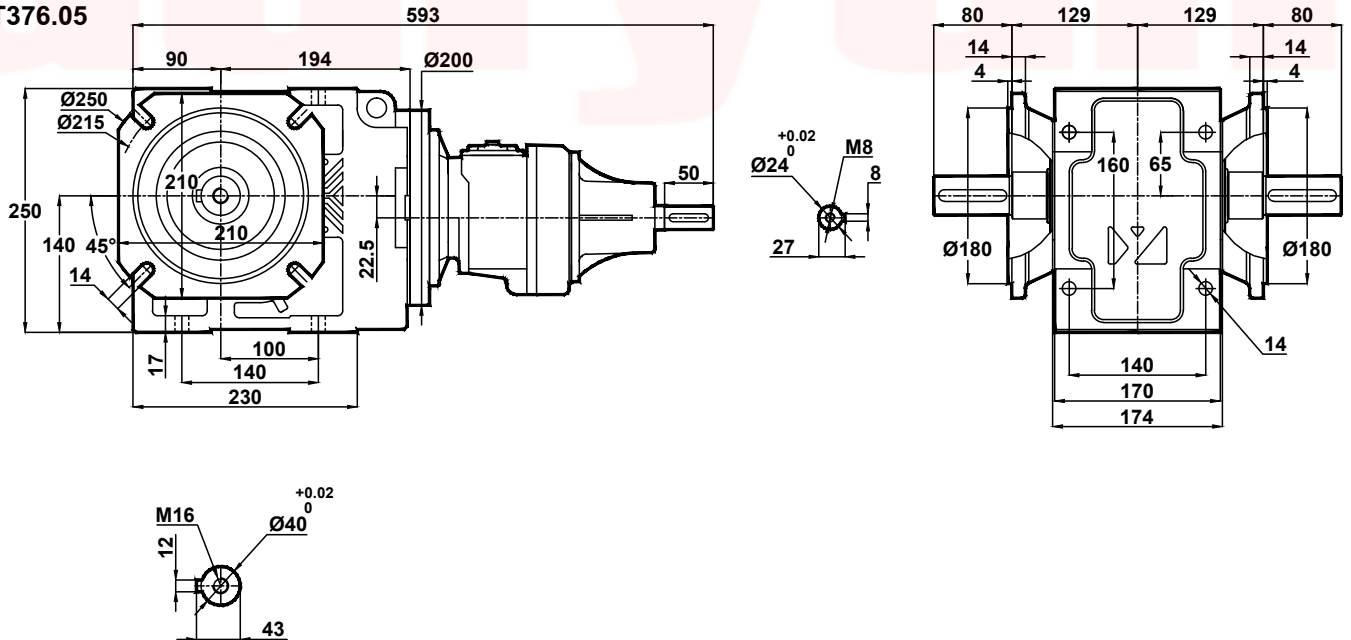



# Ölçü Sayfaları Dimension Pages Abmessungsseiten



-Mil ucu çekirme deliği DIN 332 sayfa 2 / Tapped center hole to DIN 332, sheet 2 / Zentrierung mit gewinde DIN 332, Blatt 2

KT375.08  
KT376.08

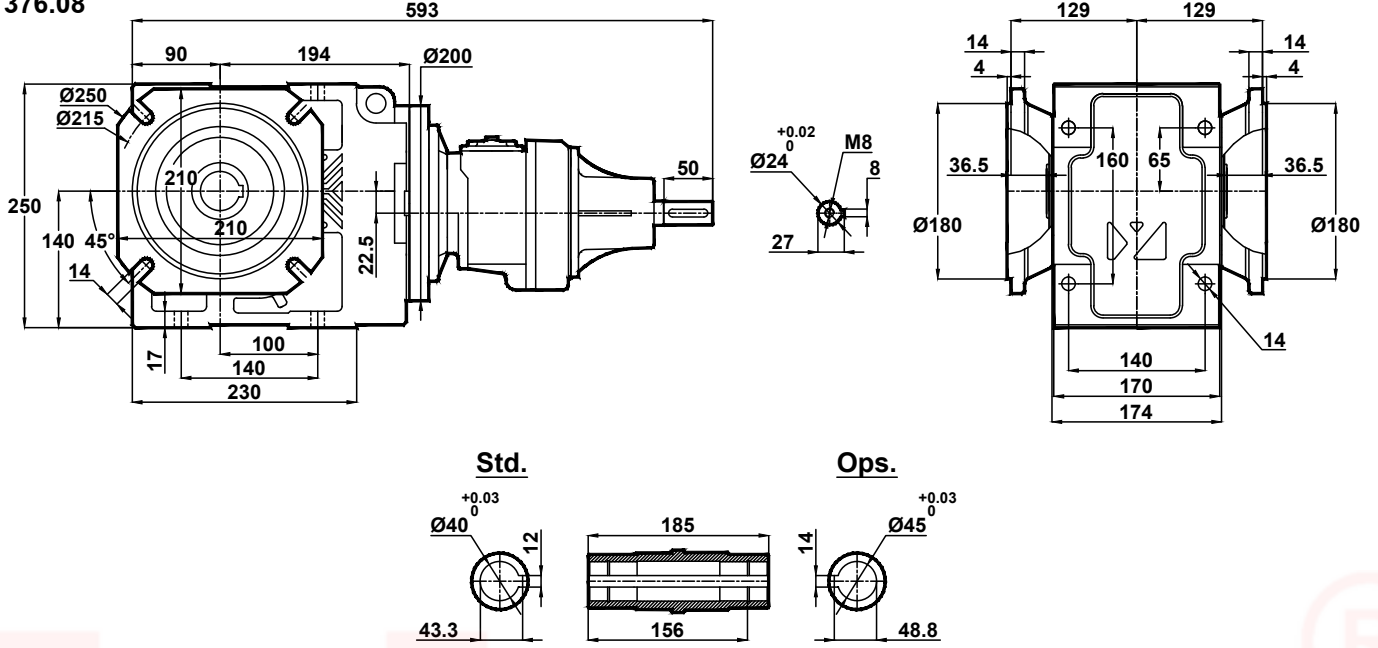



# Ölçü Sayfaları Dimension Pages Abmessungenseiten



-Mil ucu çektirme deliği DIN 332 sayfa 2 / Tapped center hole to DIN 332, sheet 2 / Zentrierung mit gewinde DIN 332, Blatt 2

KT473.00

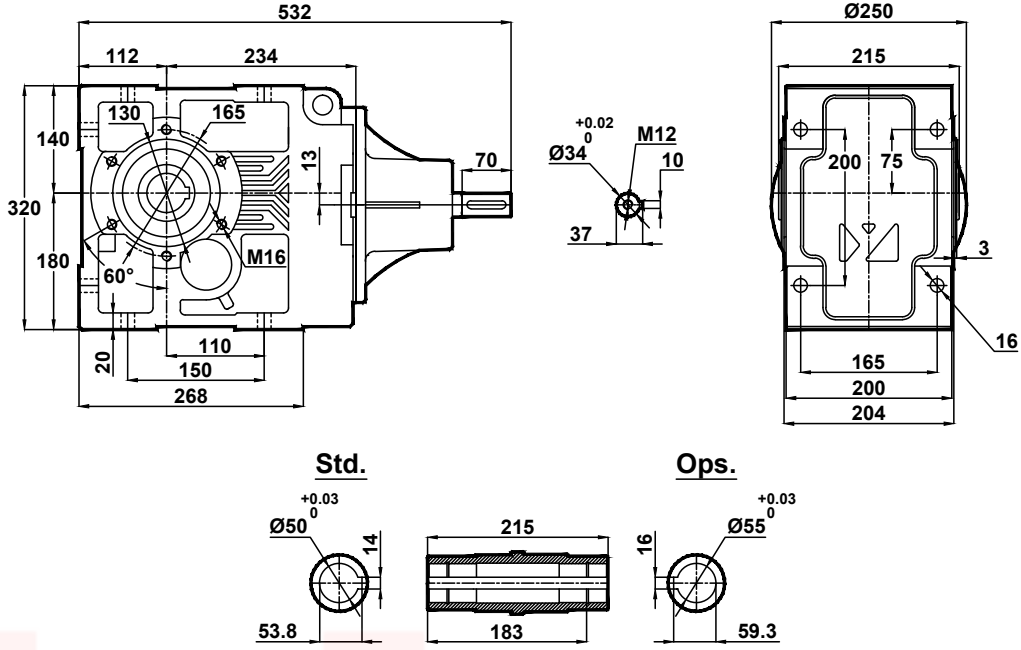

KT473.01

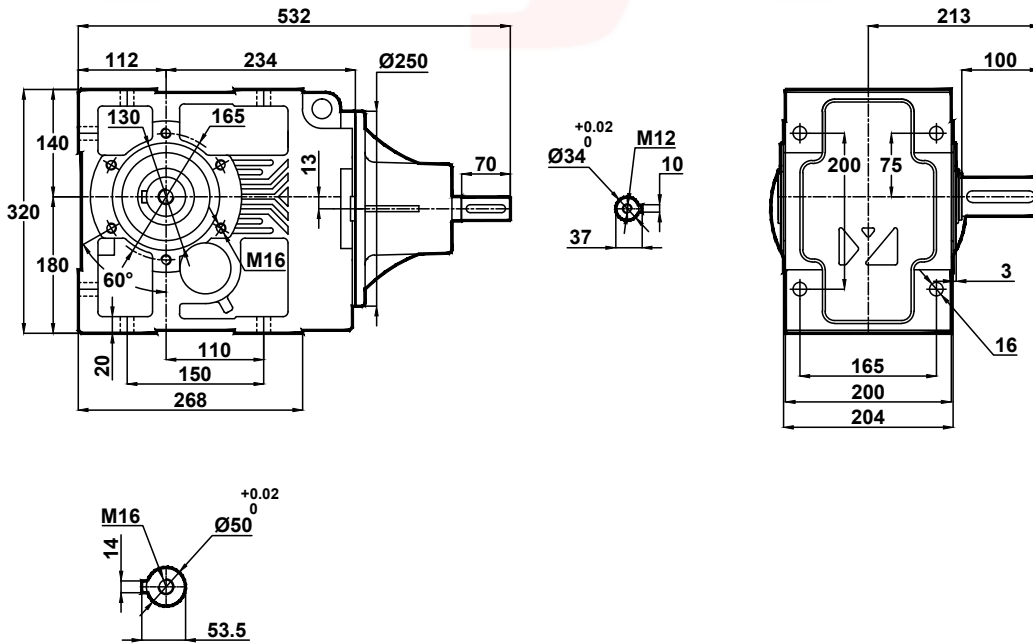



# Ölçü Sayfaları Dimension Pages Abmessungenseiten



-Mil ucu çekirme deliği DIN 332 sayfa 2 / Tapped center hole to DIN 332, sheet 2 / Zentrierung mit gewinde DIN 332, Blatt 2

KT473.02

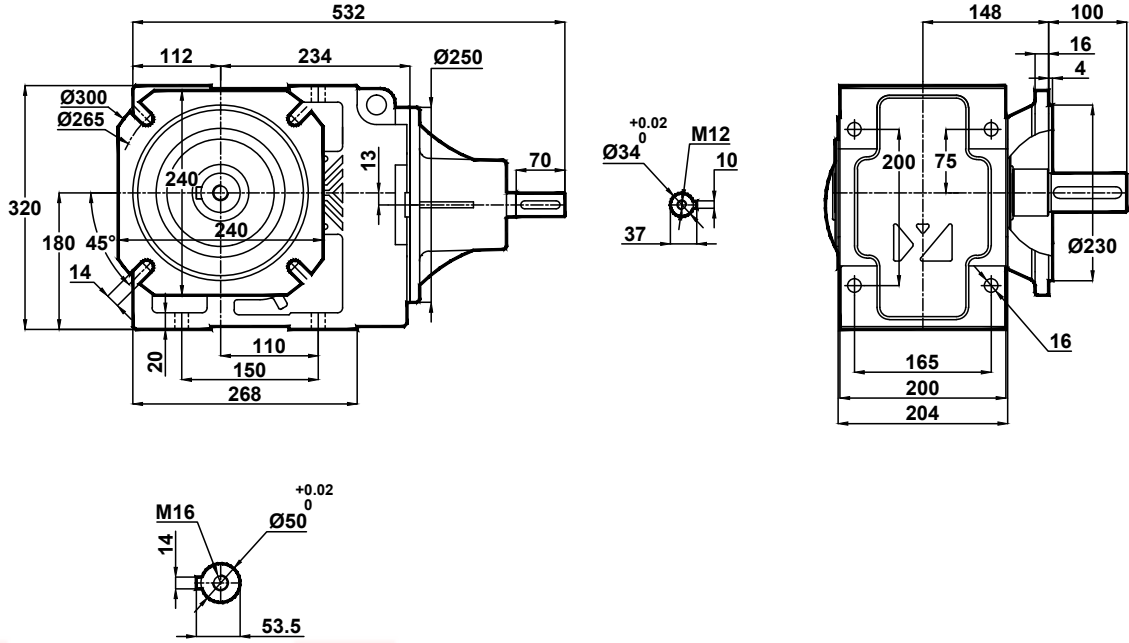

KT473.03

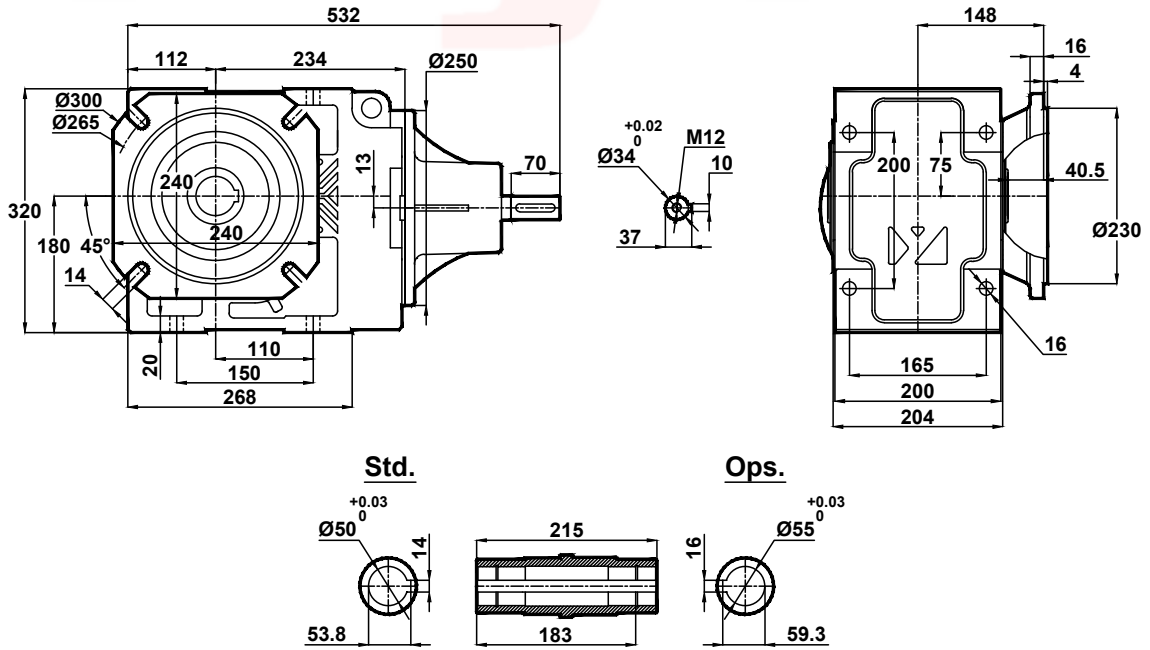



# Ölçü Sayfaları Dimension Pages Abmessungenseiten



-Mil ucu çektirme deliği DIN 332 sayfa 2 / Tapped center hole to DIN 332, sheet 2 / Zentrierung mit gewinde DIN 332, Blatt 2

KT473.04

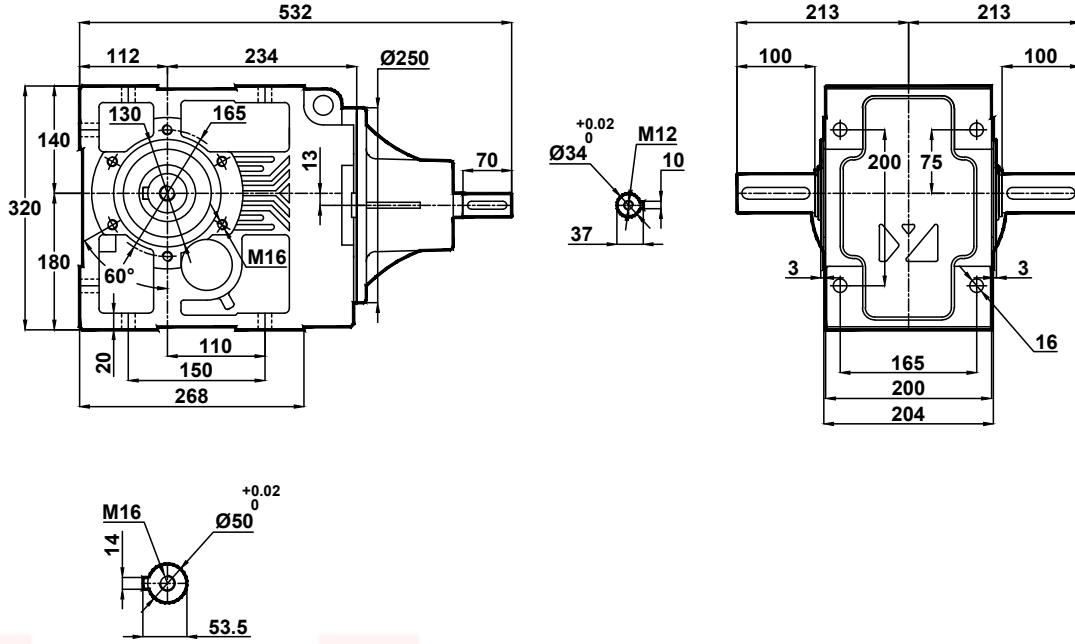

KT473.05

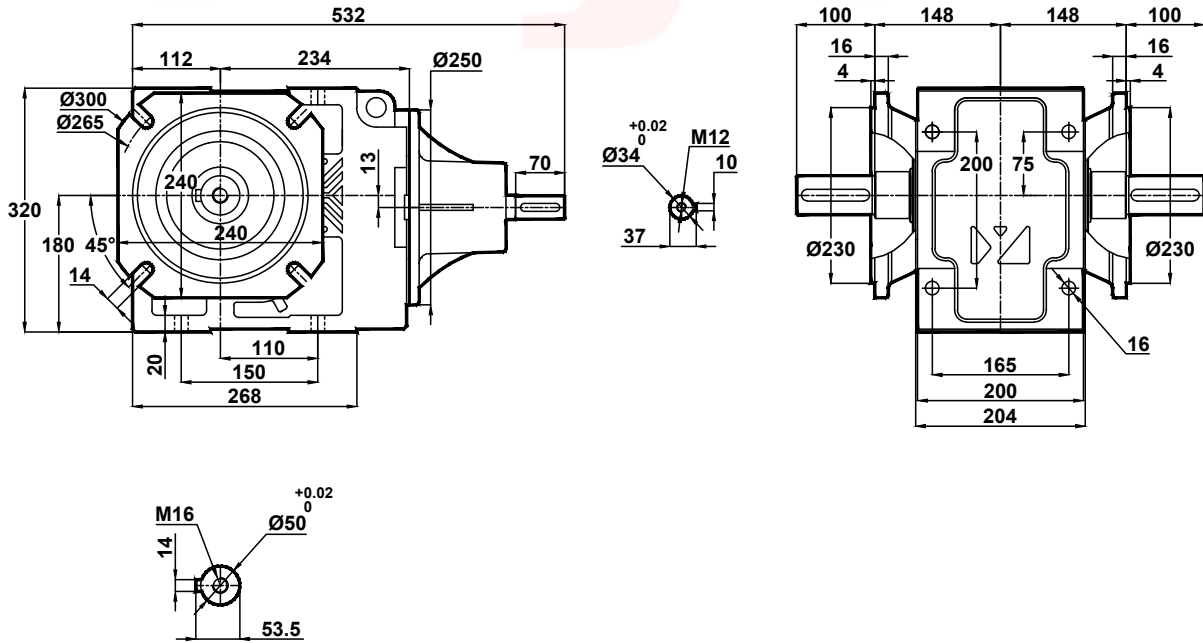





# Ölçü Sayfaları Dimension Pages Abmessungenseiten



-Mil ucu çekirme deliği DIN 332 sayfa 2 / Tapped center hole to DIN 332, sheet 2 / Zentrierung mit gewinde DIN 332, Blatt 2

KT473.08

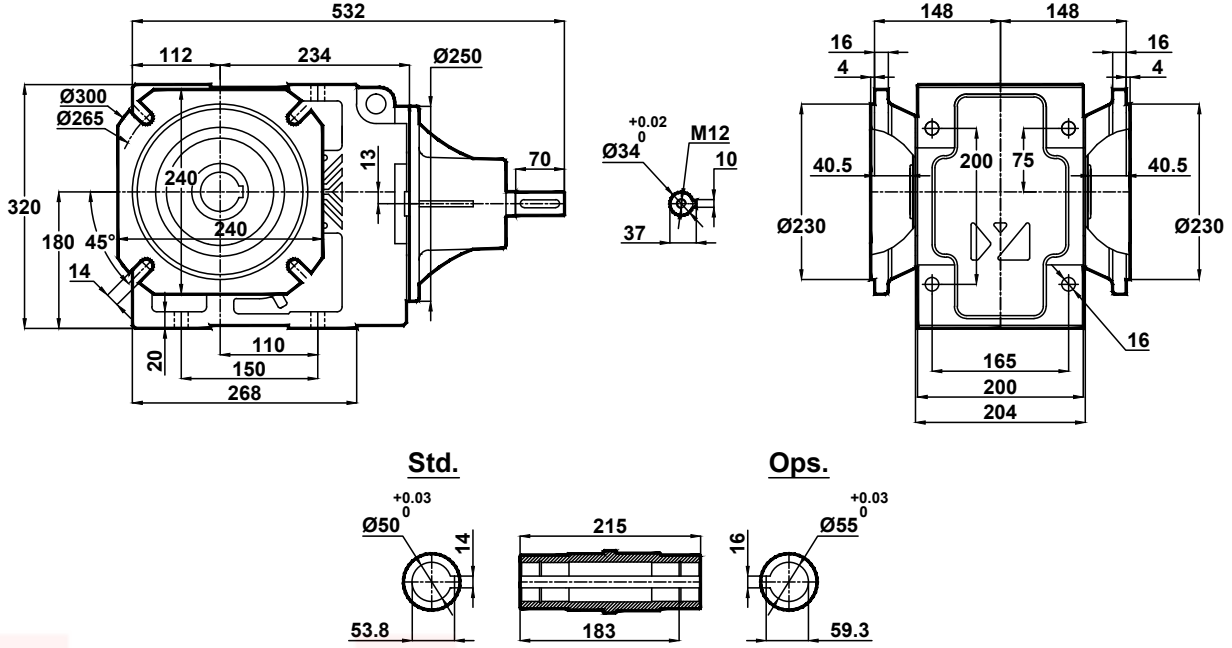



# Ölçü Sayfaları Dimension Pages Abmessungenseiten



-Mil ucu çektirme deliği DIN 332 sayfa 2 / Tapped center hole to DIN 332, sheet 2 / Zentrierung mit gewinde DIN 332, Blatt 2

KT474.00

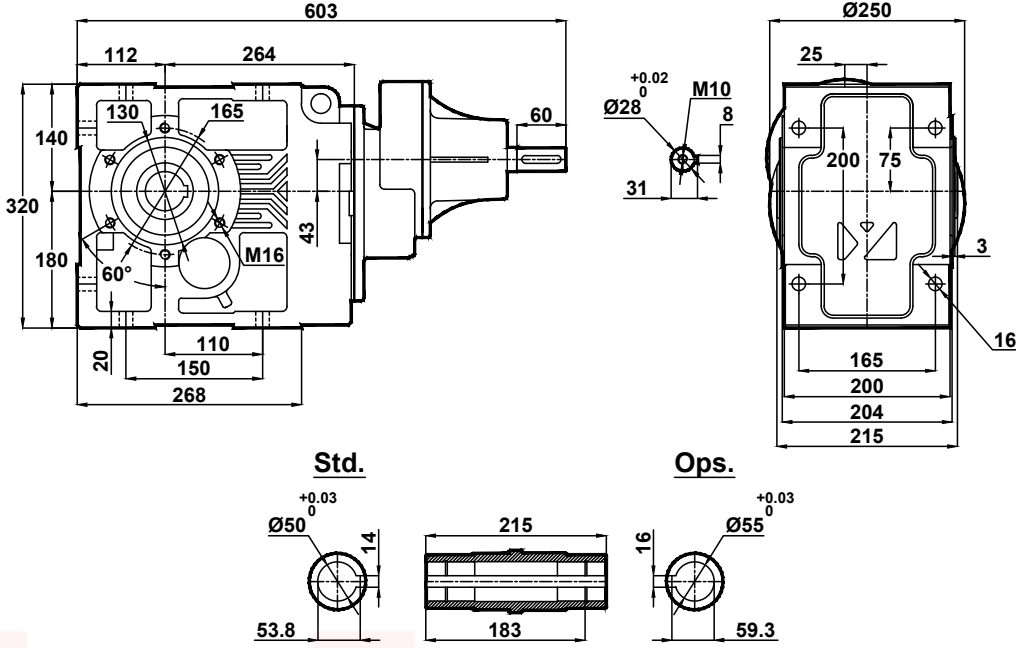

KT474.01

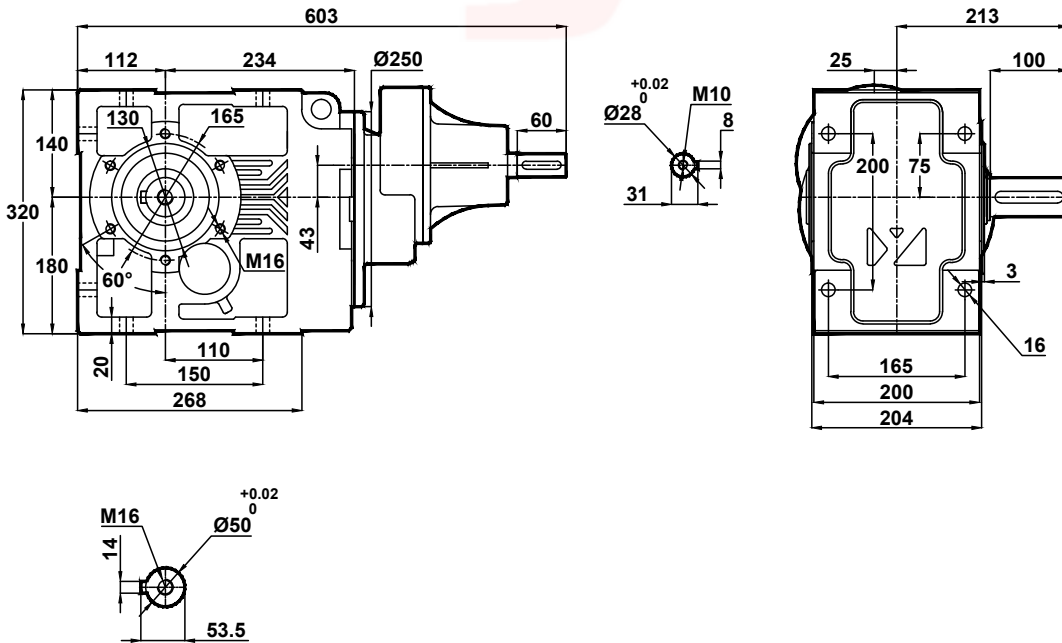



# Ölçü Sayfaları Dimension Pages Abmessungsseiten



-Mil ucu çekirme deliği DIN 332 sayfa 2 / Tapped center hole to DIN 332, sheet 2 / Zentrierung mit gewinde DIN 332, Blatt 2

KT474.02

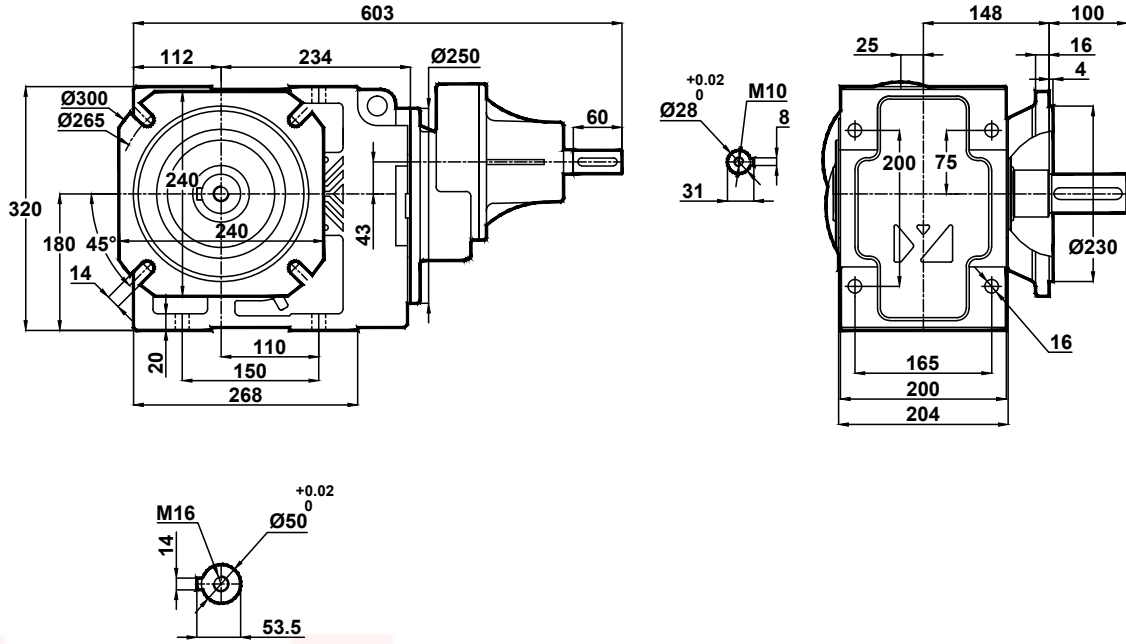

KT474.03

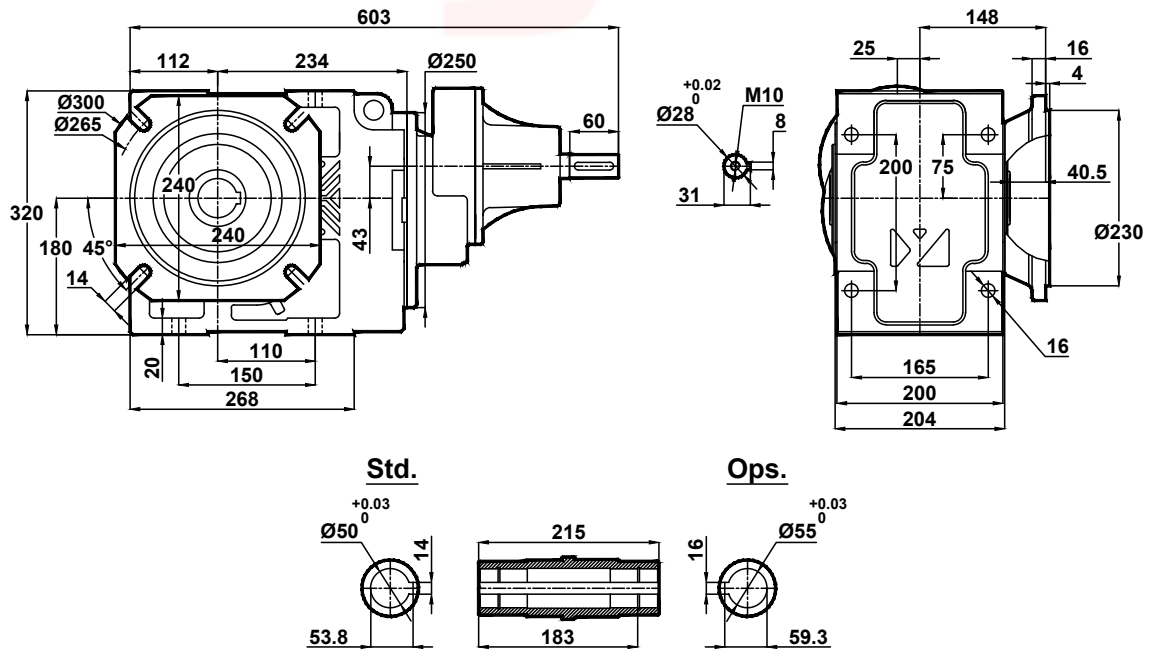



# Ölçü Sayfaları Dimension Pages Abmessungenseiten



-Mil ucu çektirme deliği DIN 332 sayfa 2 / Tapped center hole to DIN 332, sheet 2 / Zentrierung mit gewinde DIN 332, Blatt 2

## KT474.04

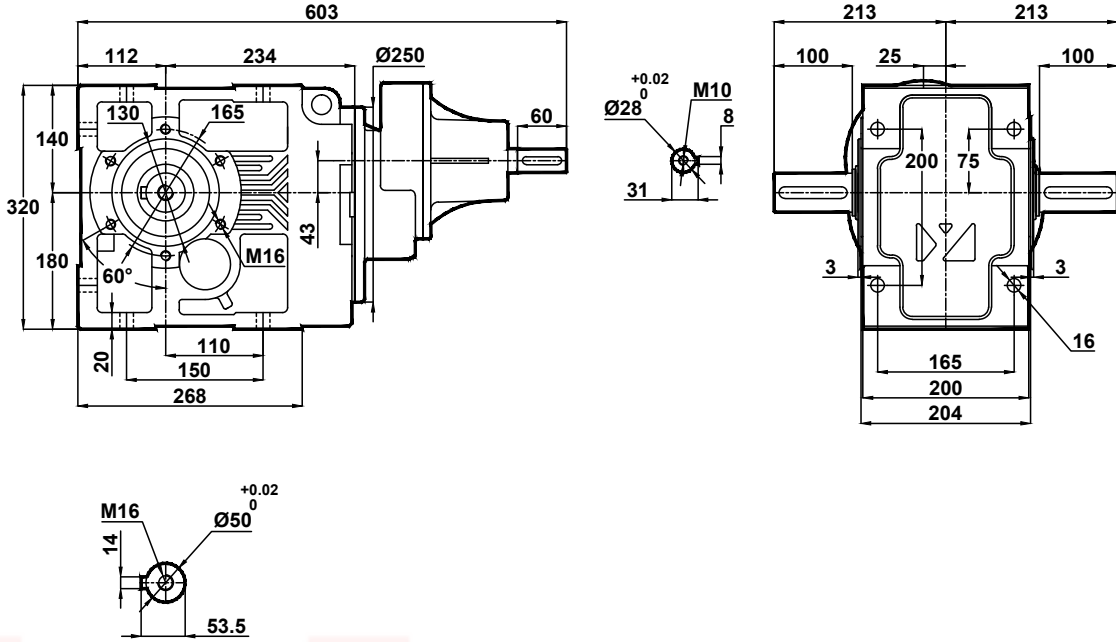

## KT474.05

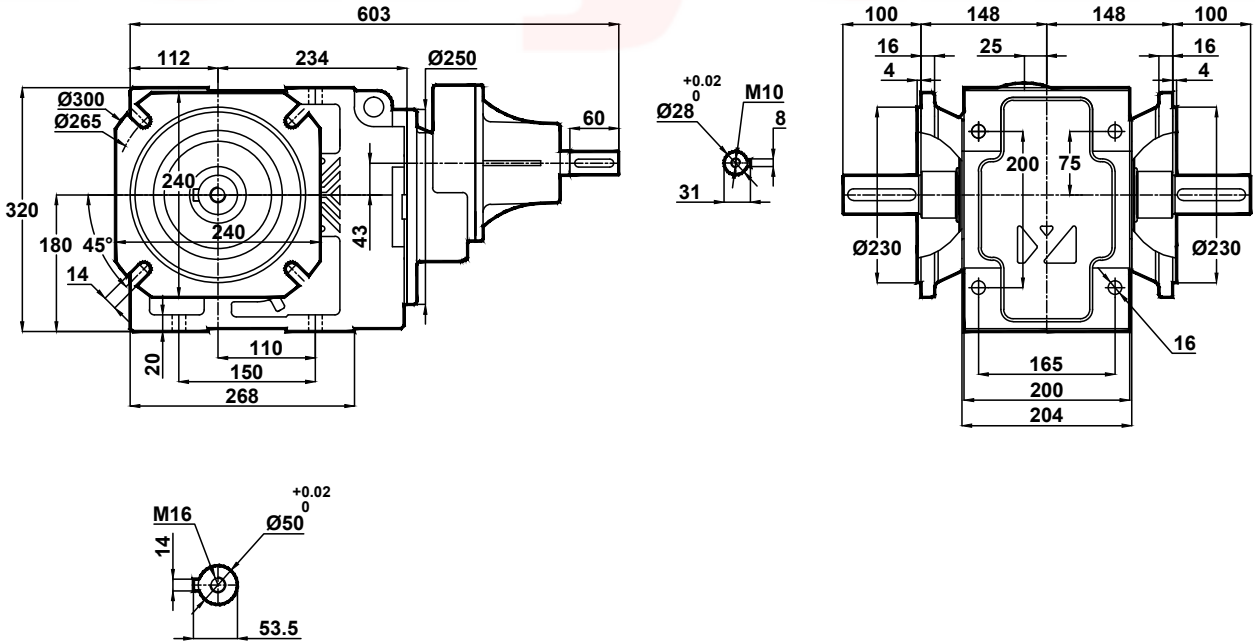



# Ölçü Sayfaları Dimension Pages Abmessungenseiten



-Mil ucu çektirme deliği DIN 332 sayfa 2 / Tapped center hole to DIN 332, sheet 2 / Zentrierung mit gewinde DIN 332, Blatt 2

KT474.08

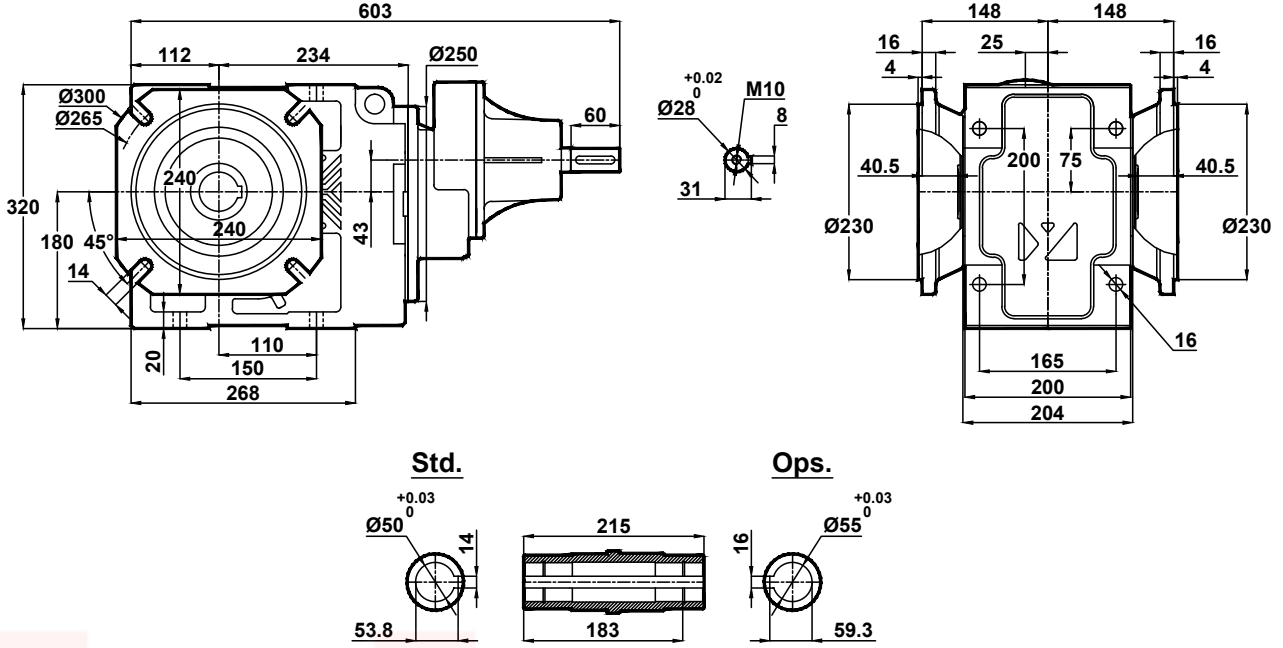



# Ölçü Sayfaları Dimension Pages Abmessungenseiten



-Mil ucu çekirme deliği DIN 332 sayfa 2 / Tapped center hole to DIN 332, sheet 2 / Zentrierung mit gewinde DIN 332, Blatt 2

KT475.00  
KT476.00

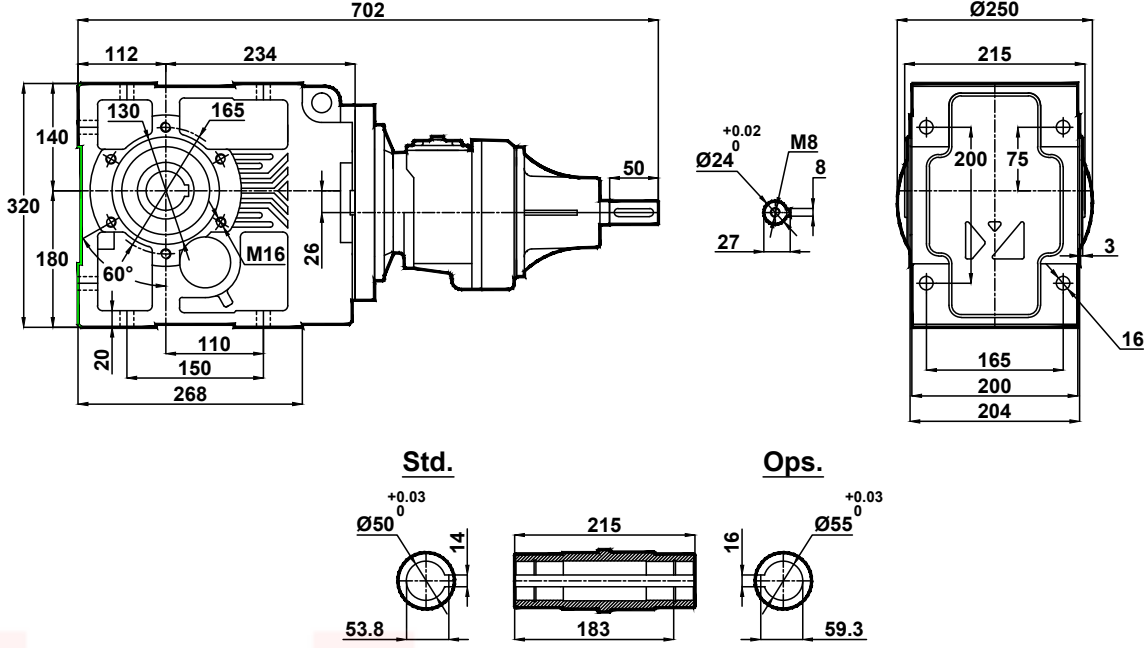

KT475.01  
KT476.01

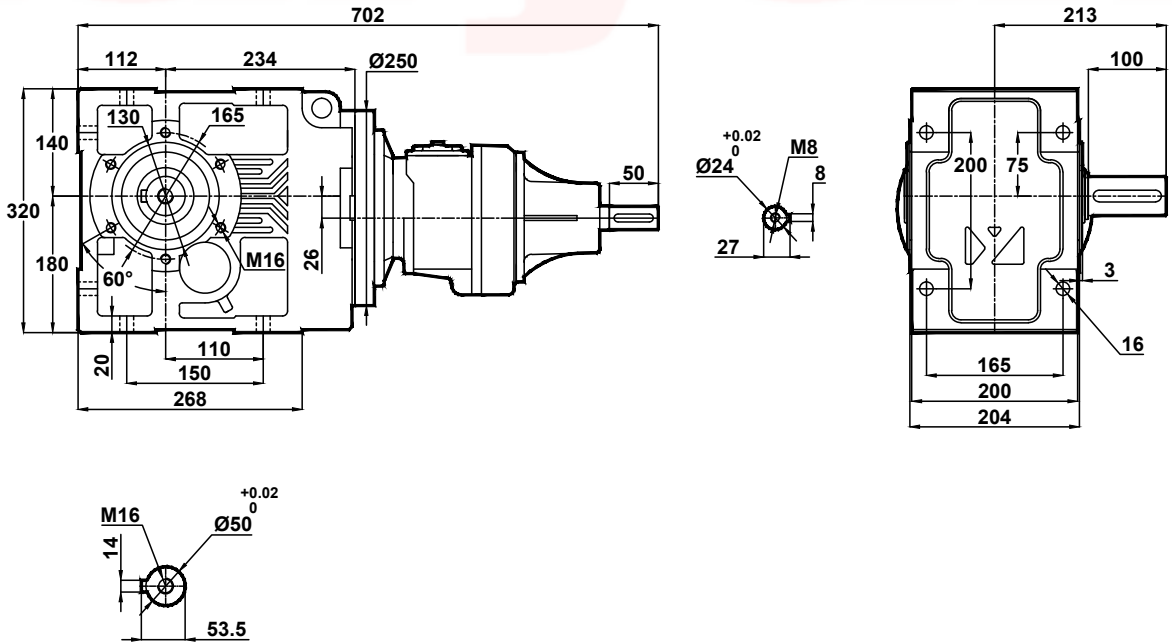



# Ölçü Sayfaları Dimension Pages Abmessungenseiten



-Mil ucu çekirme deliği DIN 332 sayfa 2 / Tapped center hole to DIN 332, sheet 2 / Zentrierung mit gewinde DIN 332, Blatt 2

KT475.02  
KT476.02

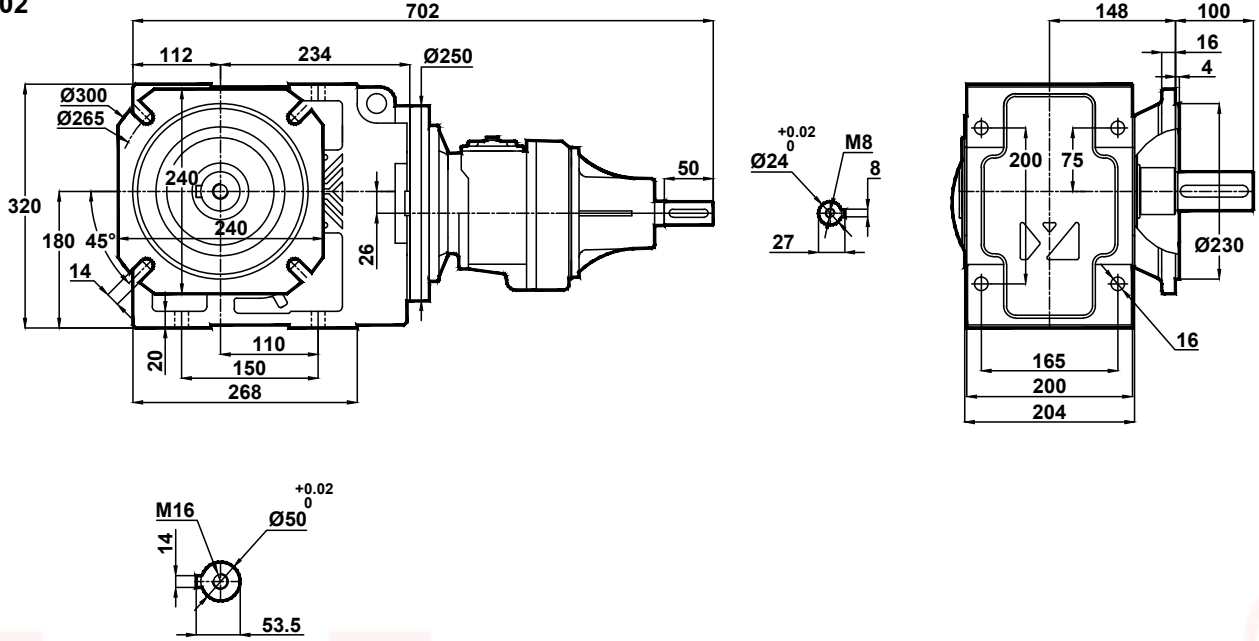

KT475.03  
KT476.03

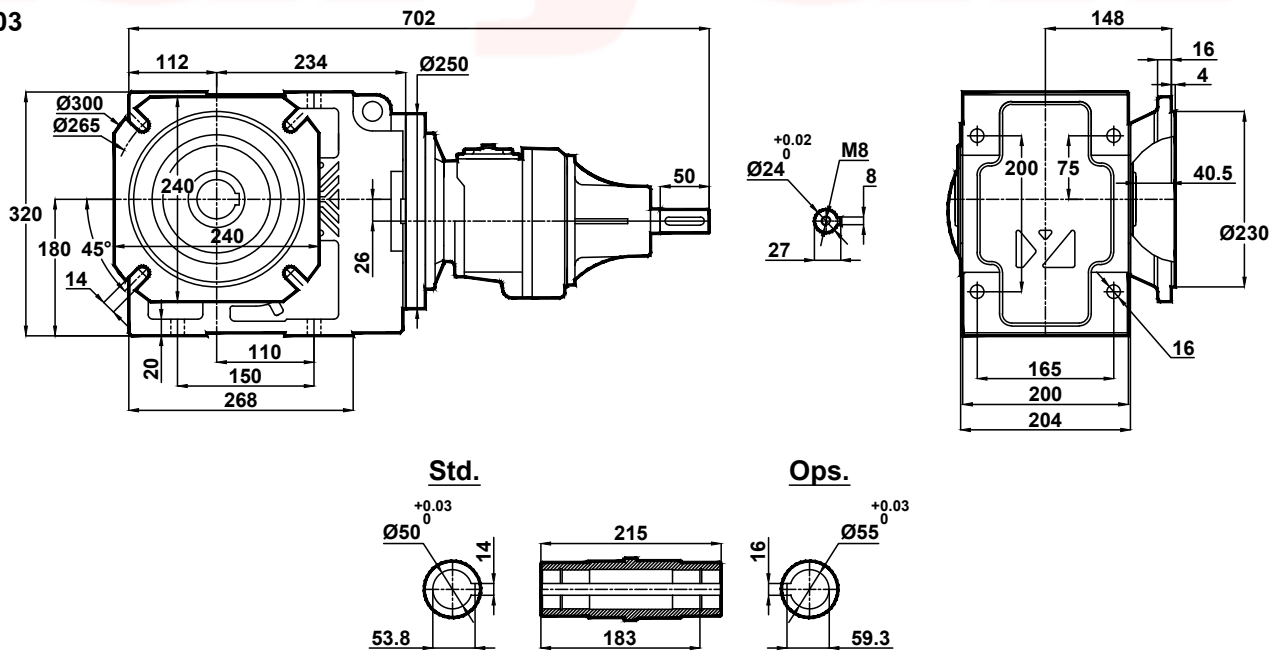



# Ölçü Sayfaları Dimension Pages Abmessungsseiten



-Mil ucu çektirme deliği DIN 332 sayfa 2 / Tapped center hole to DIN 332, sheet 2 / Zentrierung mit gewinde DIN 332, Blatt 2

KT475.04  
KT476.04

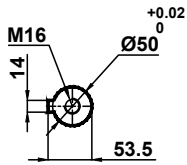
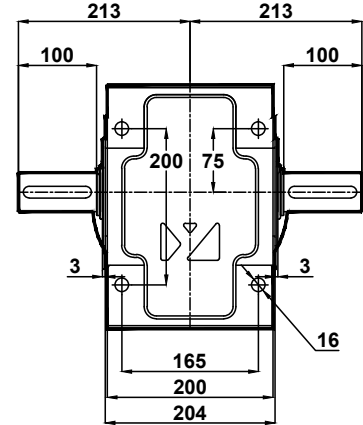
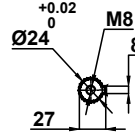
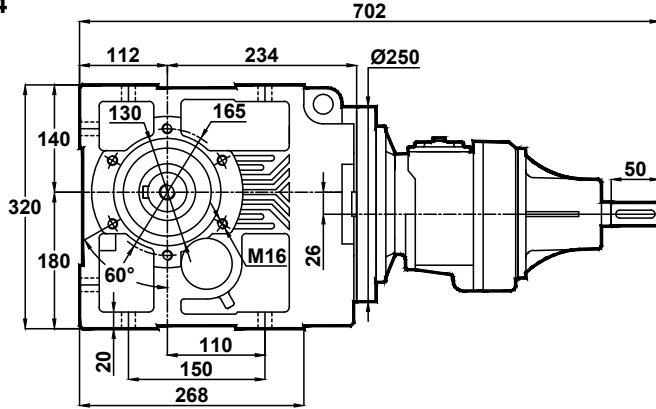

KT475.05  
KT476.05

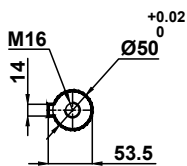
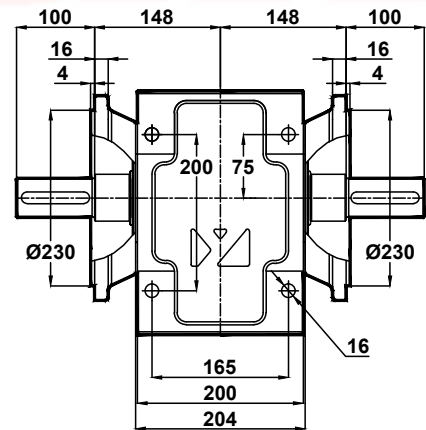
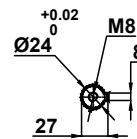
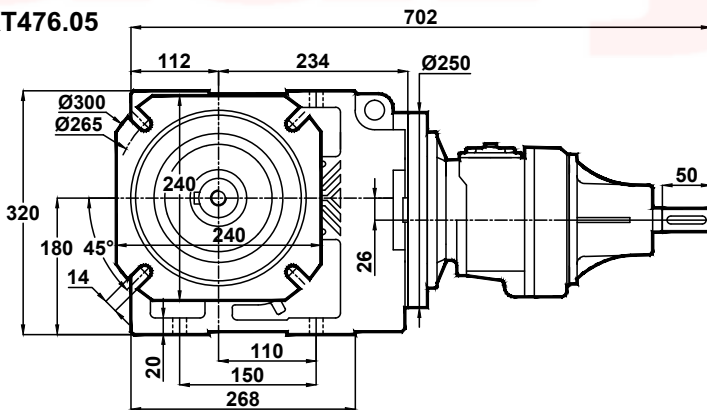





# Ölçü Sayfaları

## Dimension Pages

### Abmessungsseiten



-Mil ucu çekirme deliği DIN 332 sayfa 2 / Tapped center hole to DIN 332, sheet 2 / Zentrierung mit gewinde DIN 332, Blatt 2

KT475.08  
KT476.08

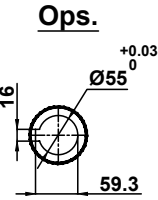
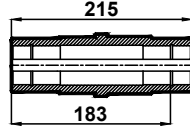
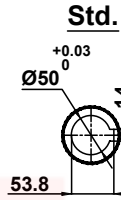
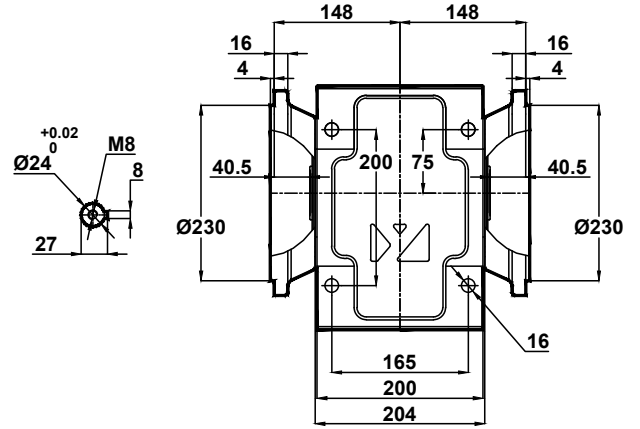
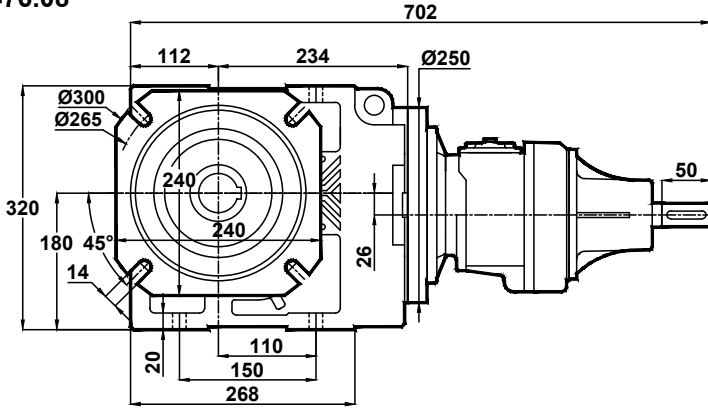



# Ölçü Sayfaları Dimension Pages Abmessungenseiten



-Mil ucu çekirme deliği DIN 332 sayfa 2 / Tapped center hole to DIN 332, sheet 2 / Zentrierung mit gewinde DIN 332, Blatt 2

KT573.00

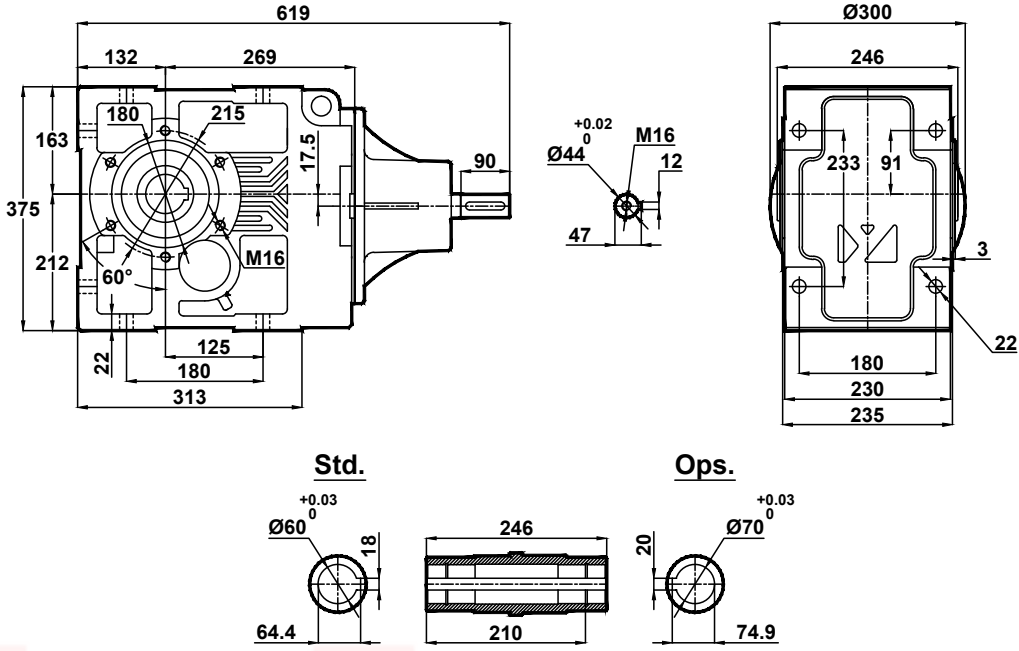

KT573.01

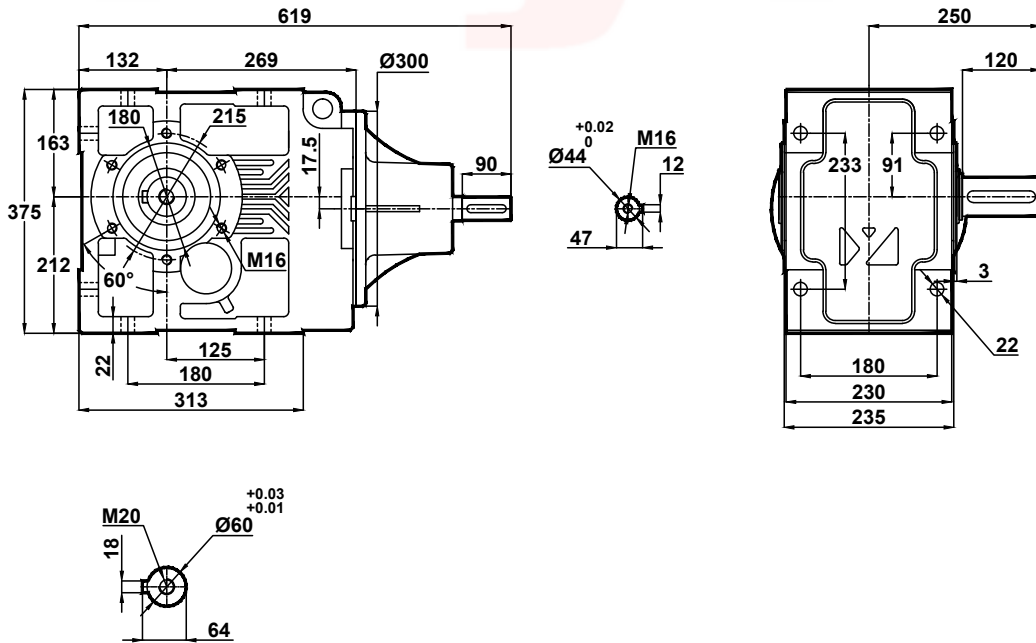



# Ölçü Sayfaları Dimension Pages Abmessungenseiten



-Mil ucu çekirme deliği DIN 332 sayfa 2 / Tapped center hole to DIN 332, sheet 2 / Zentrierung mit gewinde DIN 332, Blatt 2

KT573.02

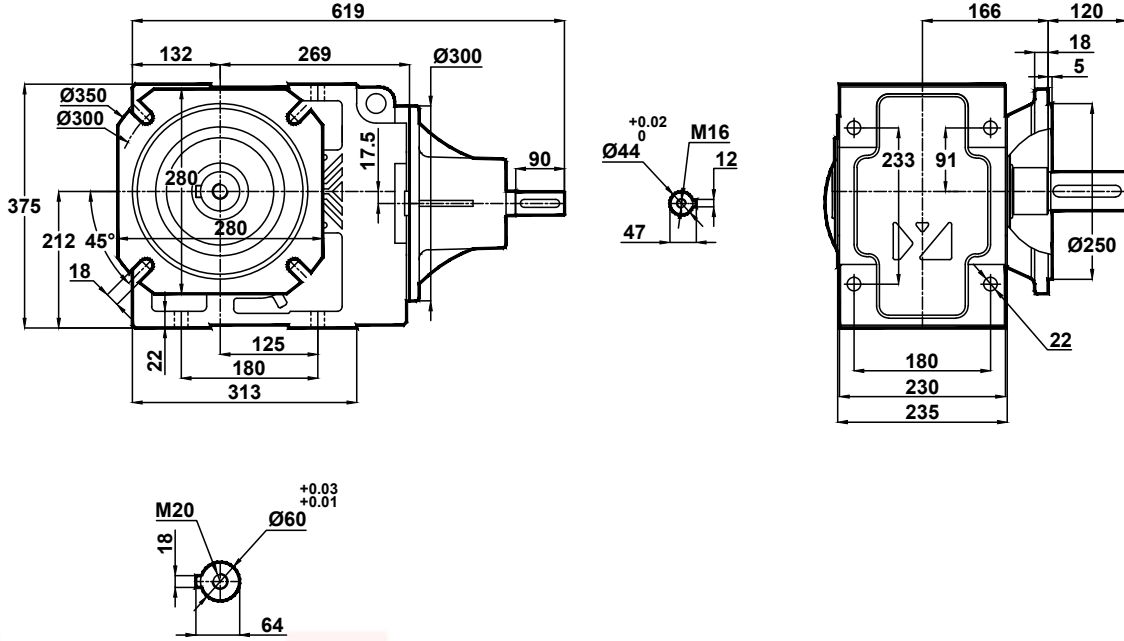

KT573.03

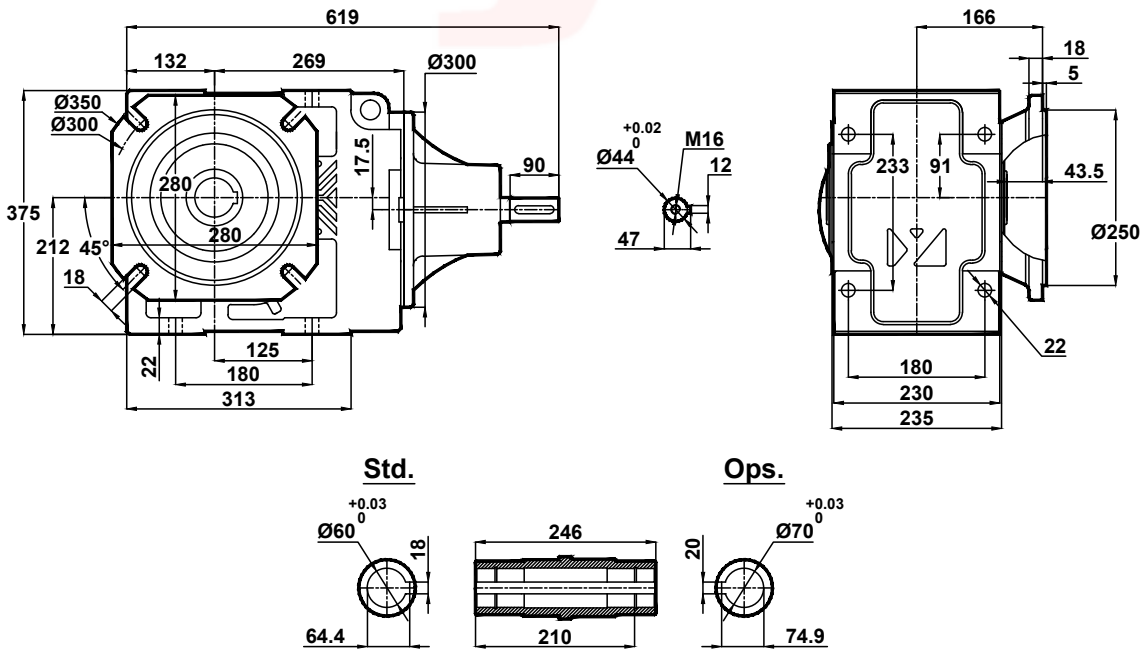



# Ölçü Sayfaları

## Dimension Pages

### Abmessungsseiten



-Mil ucu çekirme deliği DIN 332 sayfa 2 / Tapped center hole to DIN 332, sheet 2 / Zentrierung mit gewinde DIN 332, Blatt 2

KT573.04

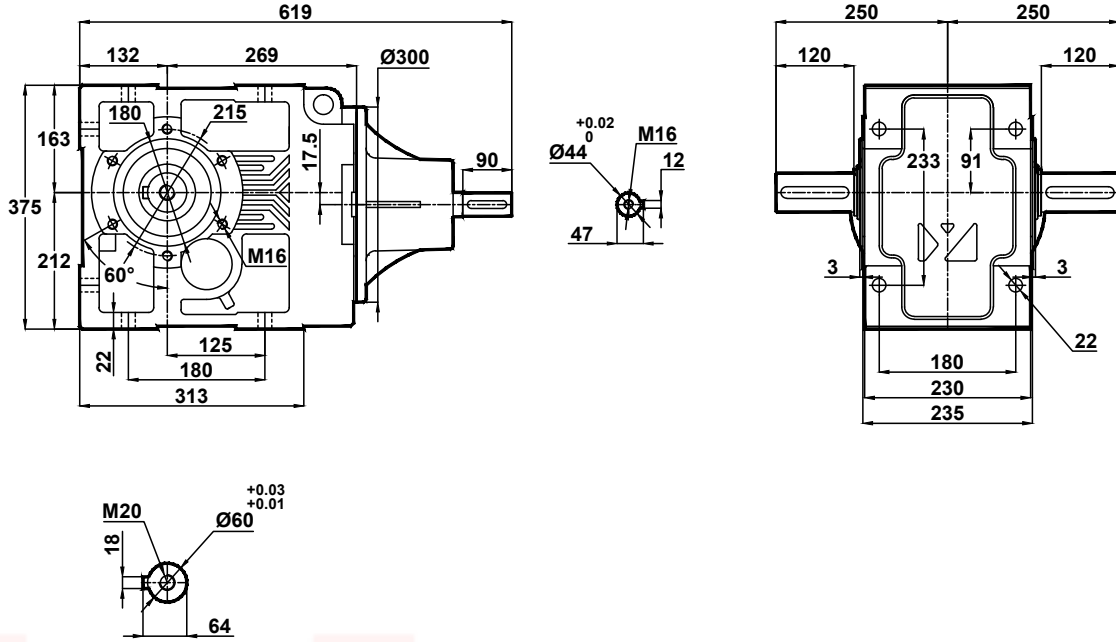

KT573.05

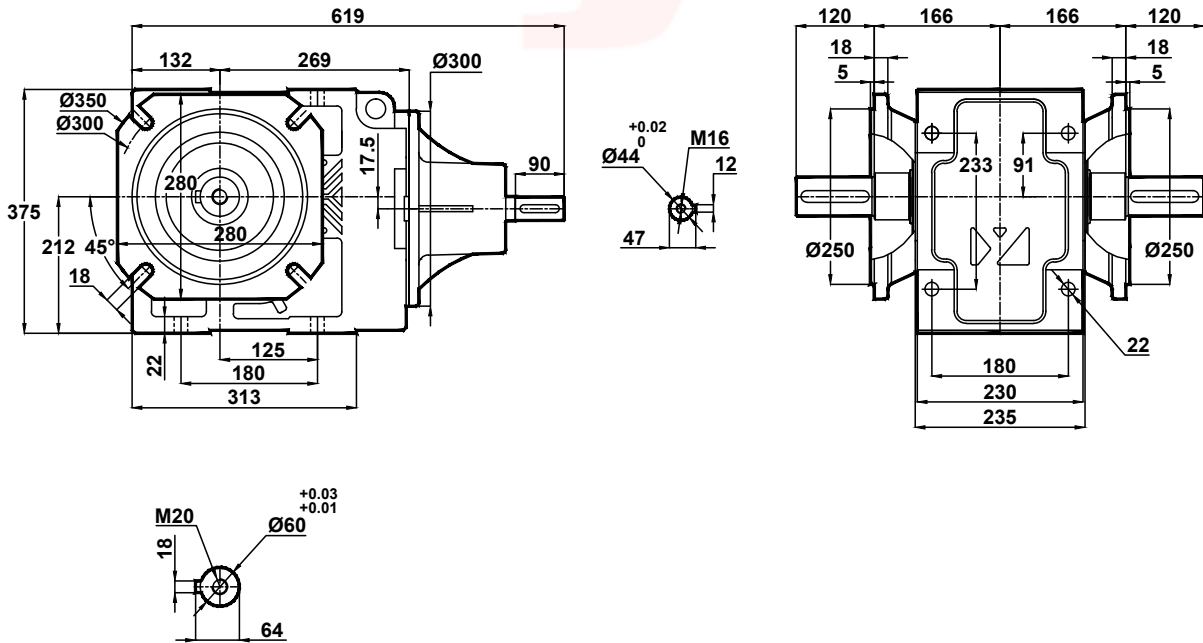



# Ölçü Sayfaları Dimension Pages Abmessungenseiten



-Mil ucu çekirme deliği DIN 332 sayfa 2 / Tapped center hole to DIN 332, sheet 2 / Zentrierung mit gewinde DIN 332, Blatt 2

KT573.08

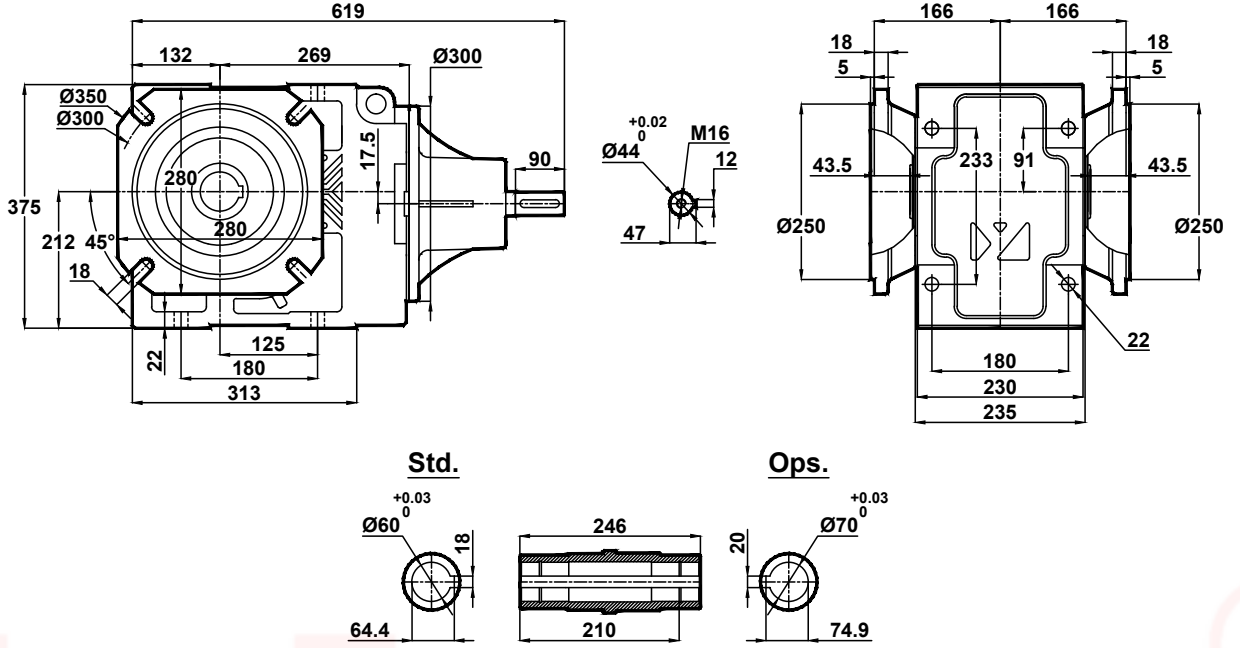



# Ölçü Sayfaları Dimension Pages Abmessungenseiten



-Mil ucu çekirme deliği DIN 332 sayfa 2 / Tapped center hole to DIN 332, sheet 2 / Zentrierung mit gewinde DIN 332, Blatt 2

KT574.00

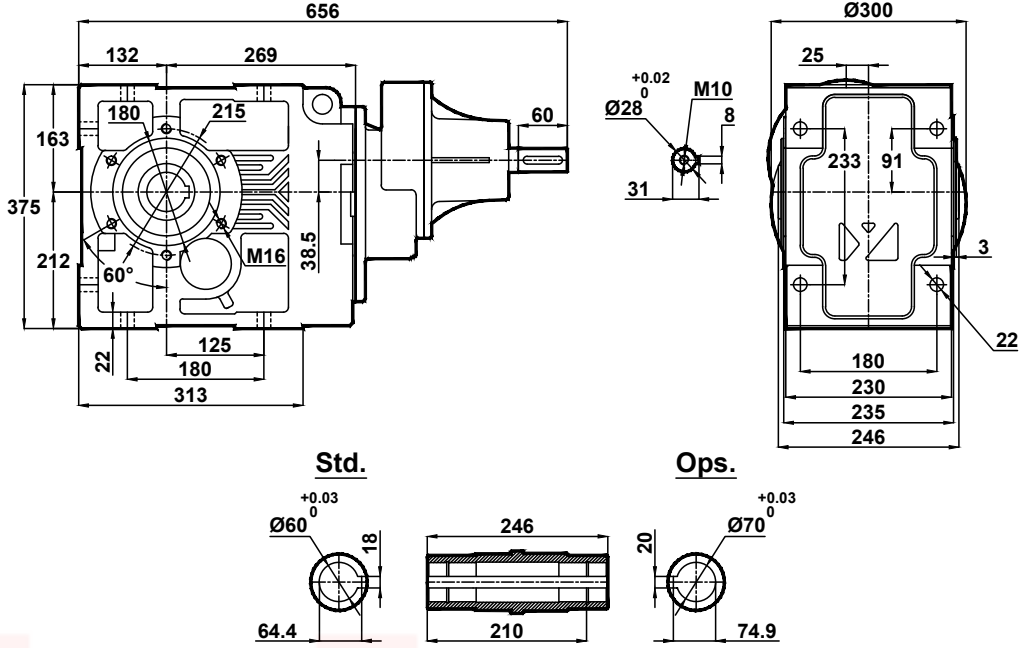

KT574.01

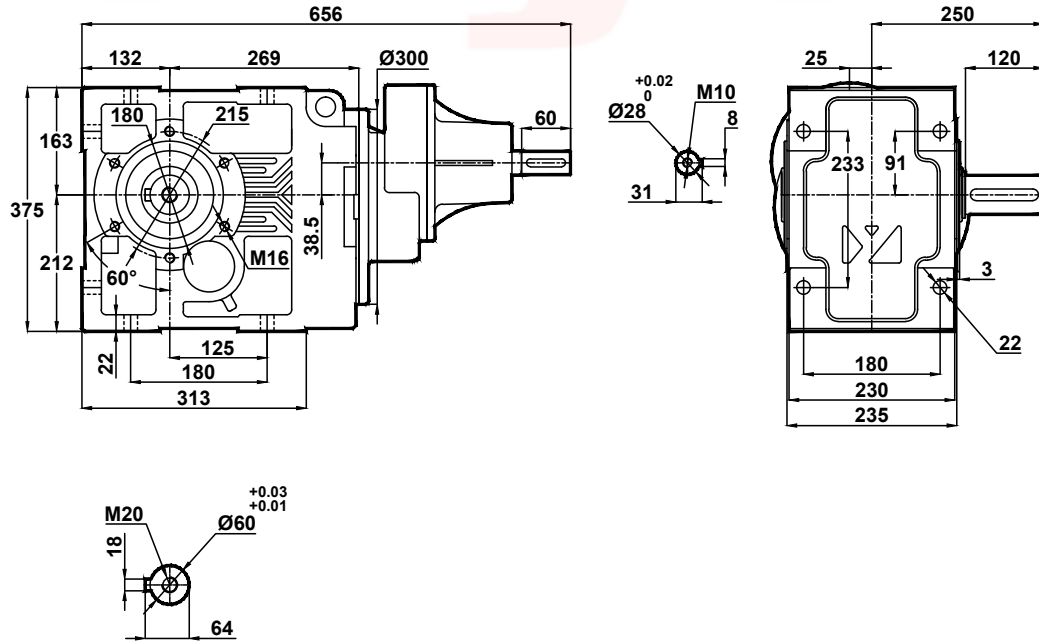



# Ölçü Sayfaları Dimension Pages Abmessungenseiten



-Mil ucu çekirme deliği DIN 332 sayfa 2 / Tapped center hole to DIN 332, sheet 2 / Zentrierung mit gewinde DIN 332, Blatt 2

KT574.02

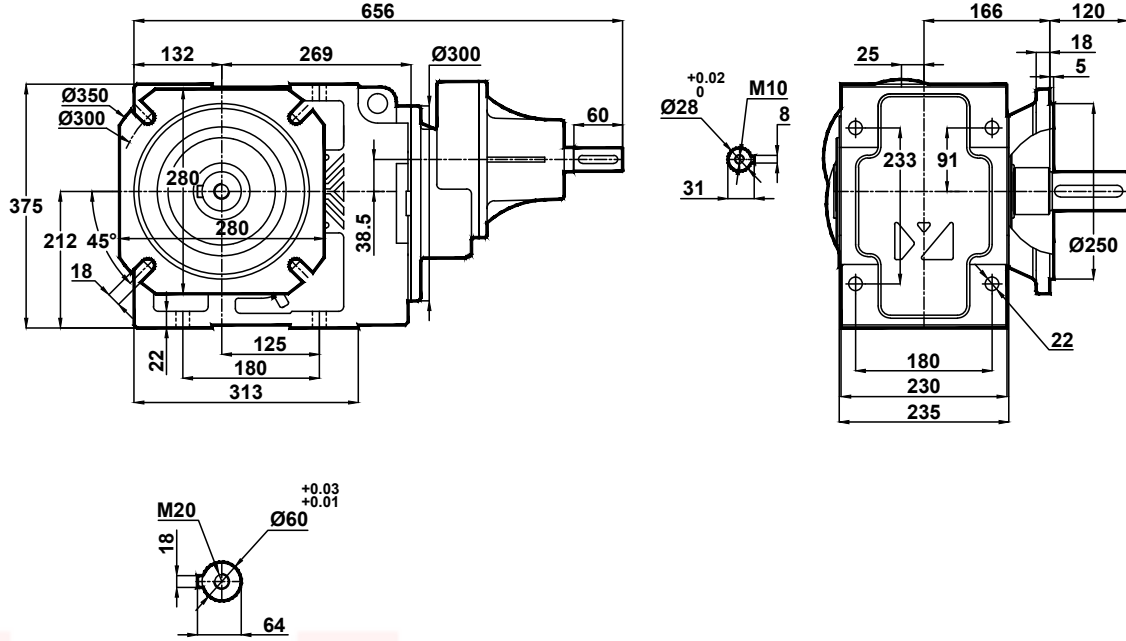

KT574.03

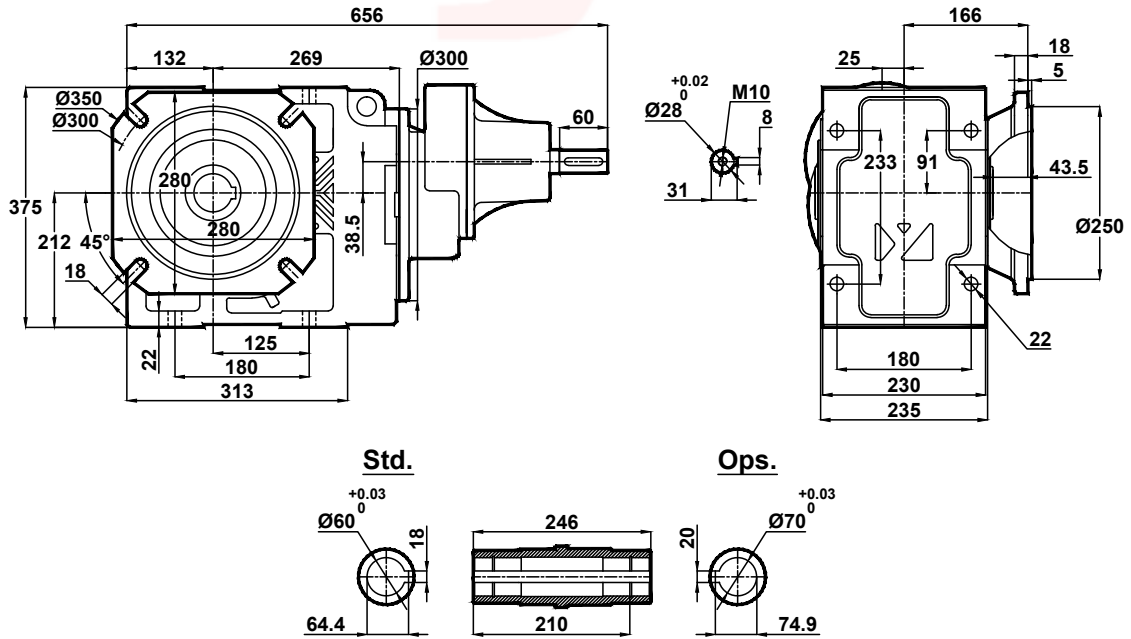



# Ölçü Sayfaları

## Dimension Pages

### Abmessungsseiten



-Mil ucu çekirme deliği DIN 332 sayfa 2 / Tapped center hole to DIN 332, sheet 2 / Zentrierung mit gewinde DIN 332, Blatt 2

KT574.04

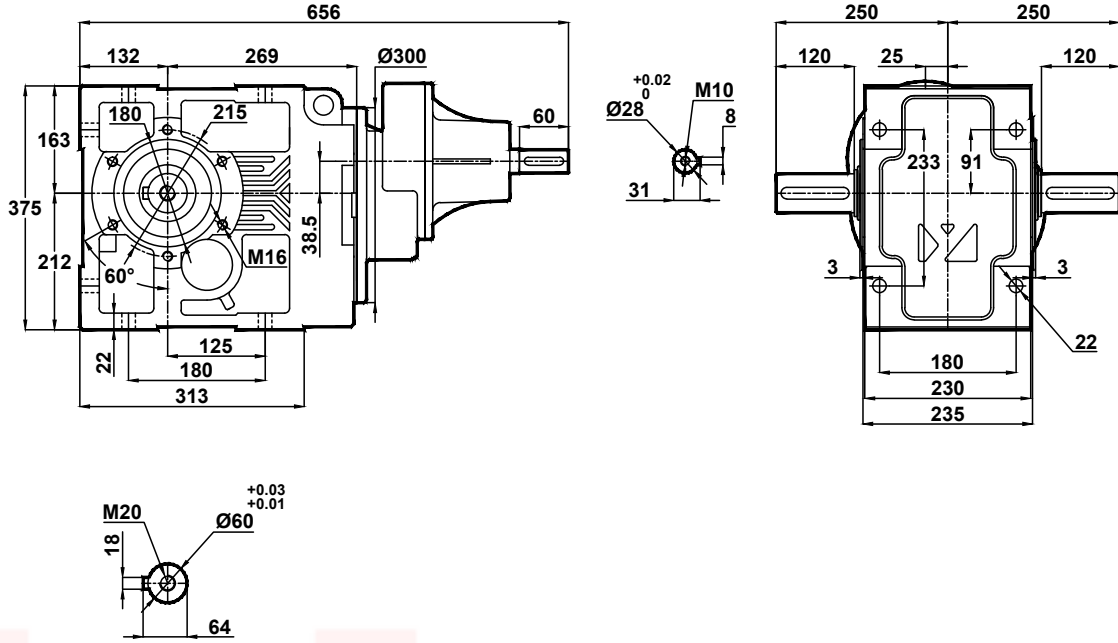

KT574.05

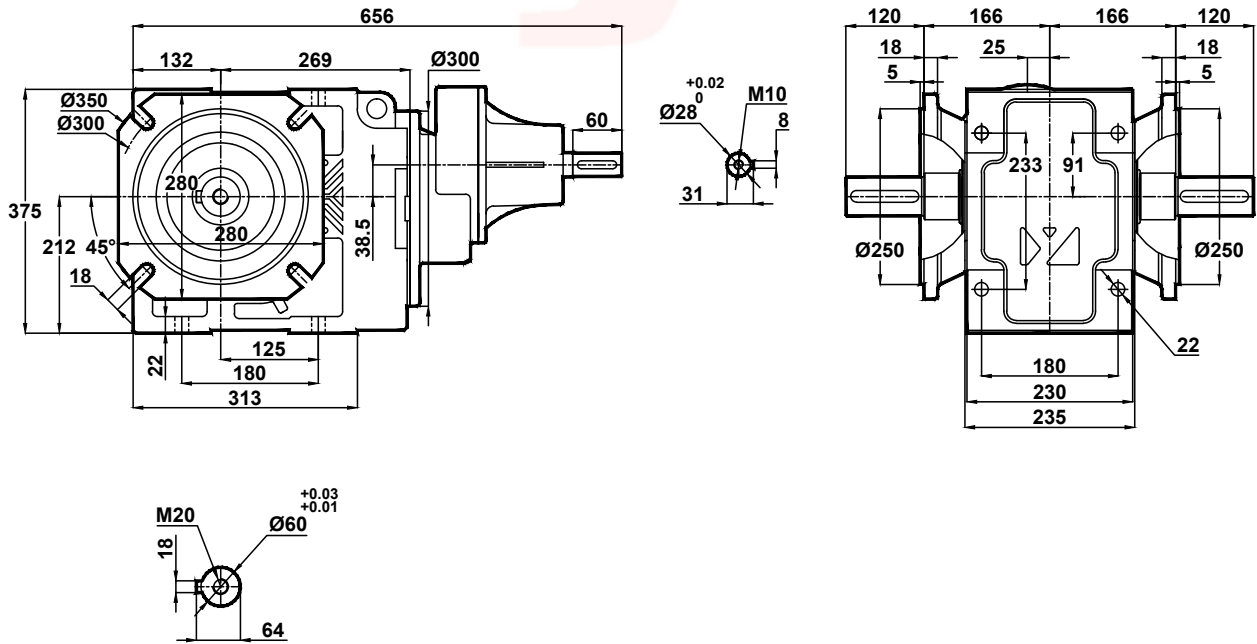





# Ölçü Sayfaları Dimension Pages Abmessungenseiten



-Mil ucu çekirme deliği DIN 332 sayfa 2 / Tapped center hole to DIN 332, sheet 2 / Zentrierung mit gewinde DIN 332, Blatt 2

KT574.08

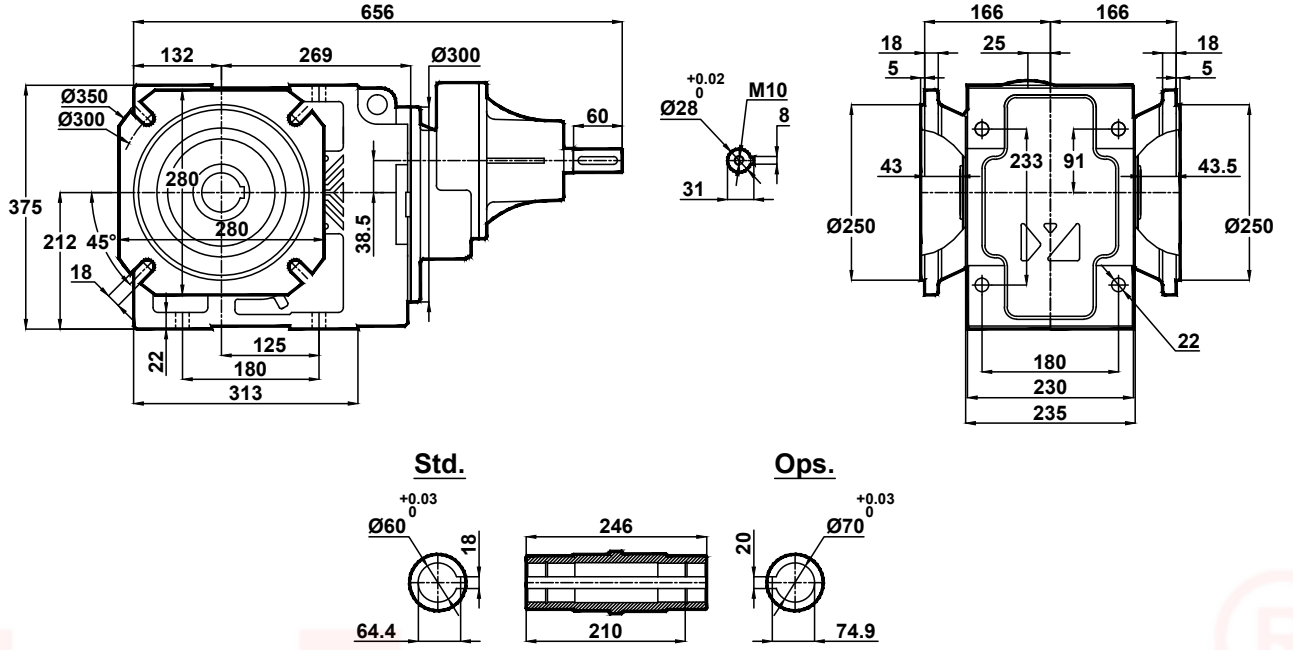



# Ölçü Sayfaları Dimension Pages Abmessungenseiten



-Mil ucu çekirme deliği DIN 332 sayfa 2 / Tapped center hole to DIN 332, sheet 2 / Zentrierung mit gewinde DIN 332, Blatt 2

KT575.00  
KT576.00

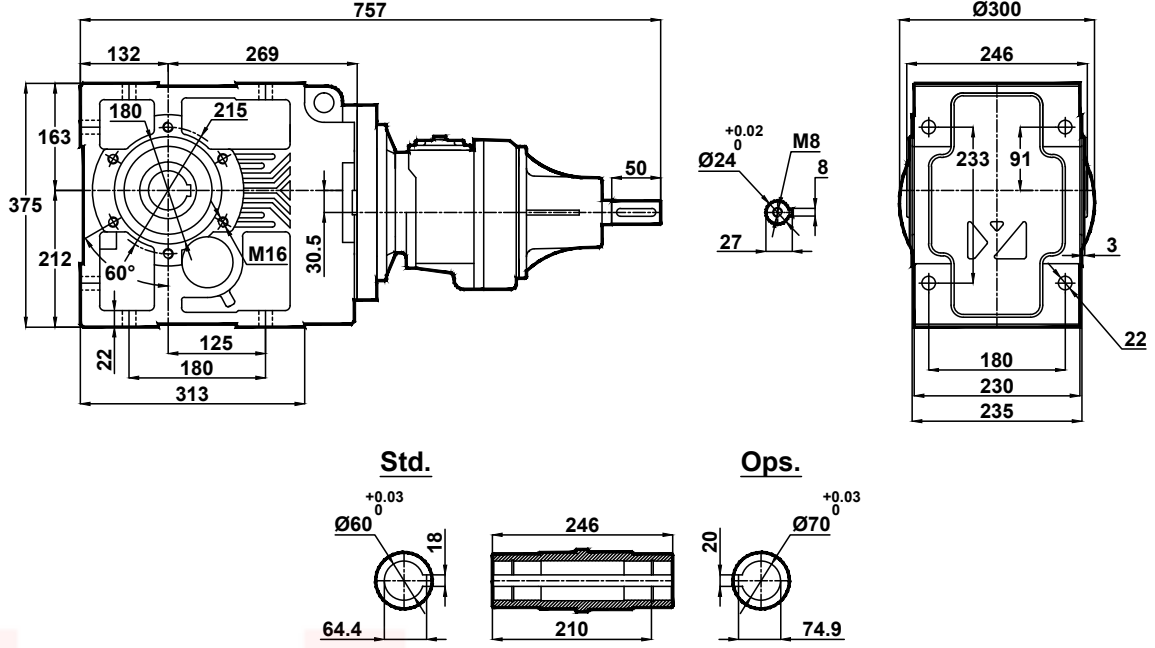

KT575.01  
KT576.01

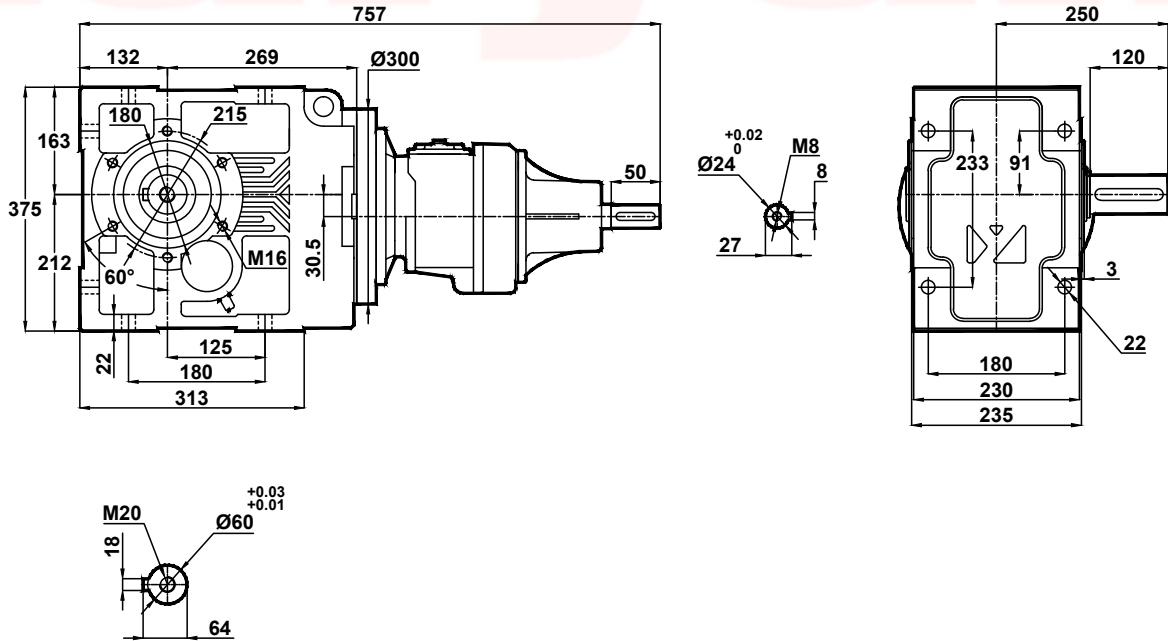



# Ölçü Sayfaları Dimension Pages Abmessungsseiten



-Mil ucu çekirme deliği DIN 332 sayfa 2 / Tapped center hole to DIN 332, sheet 2 / Zentrierung mit gewinde DIN 332, Blatt 2

KT575.02  
KT576.02

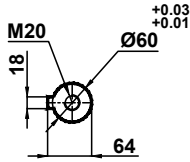
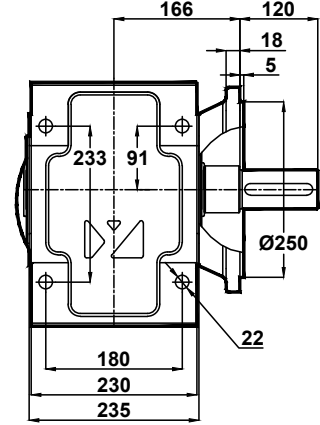
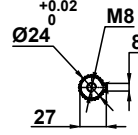
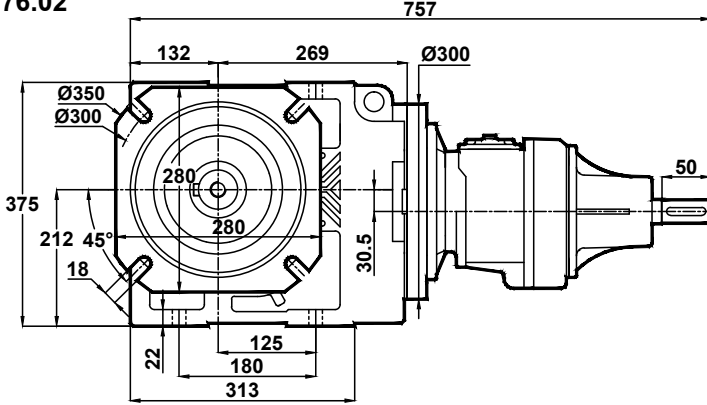

KT575.03  
KT576.03

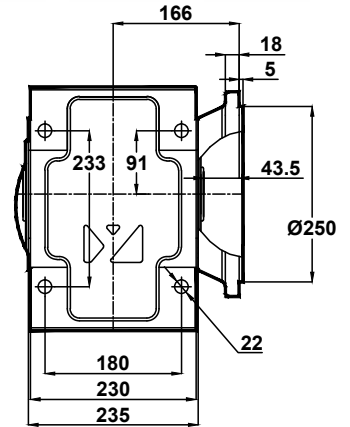
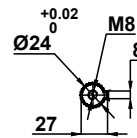
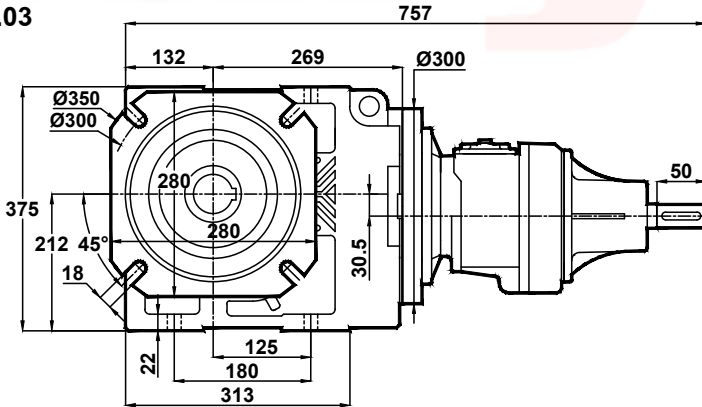

Std.

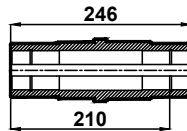
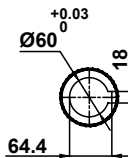

Ops.

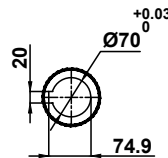



# Ölçü Sayfaları

## Dimension Pages

### Abmessungsseiten



-Mil ucu çektirme deliği DIN 332 sayfa 2 / Tapped center hole to DIN 332, sheet 2 / Zentrierung mit gewinde DIN 332, Blatt 2

KT575.04  
KT576.04

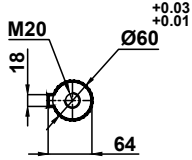
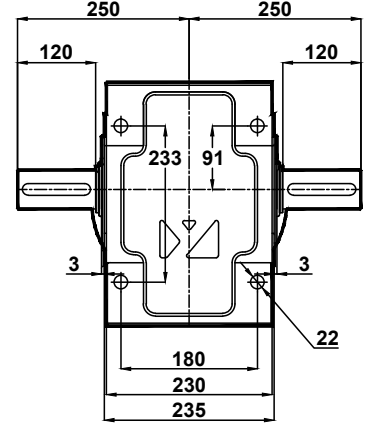
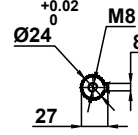
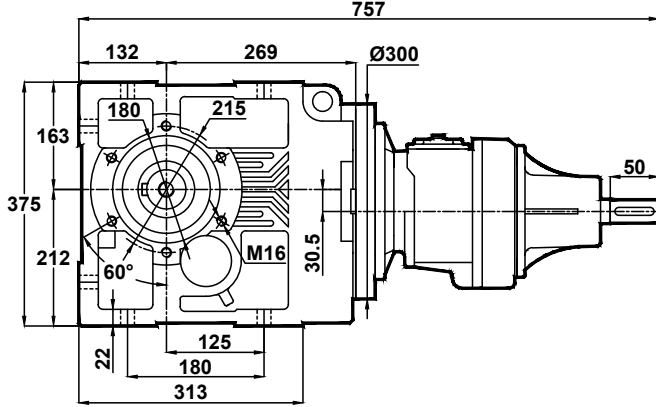

KT575.05  
KT576.05

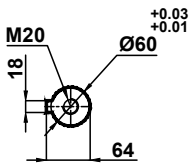
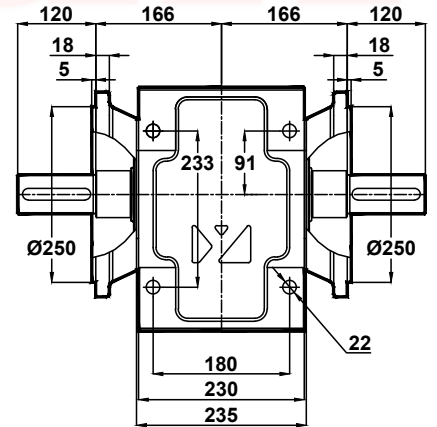
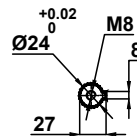
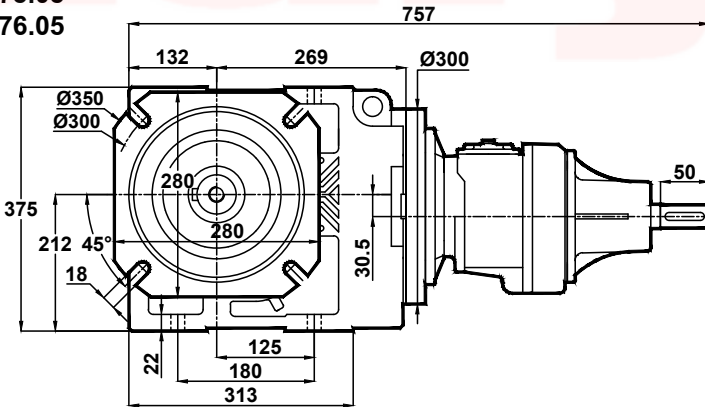



# Ölçü Sayfaları Dimension Pages Abmessungenseiten



-Mil ucu çekirme deliği DIN 332 sayfa 2 / Tapped center hole to DIN 332, sheet 2 / Zentrierung mit gewinde DIN 332, Blatt 2

KT575.08  
KT576.08

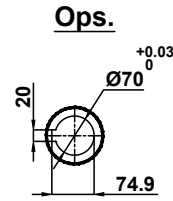
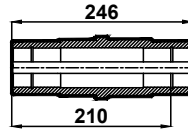
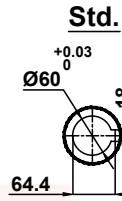
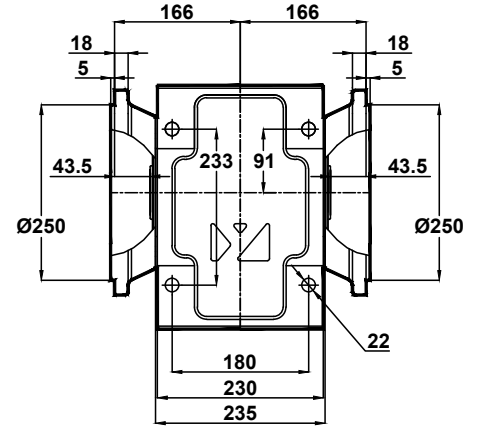
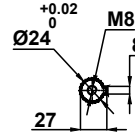
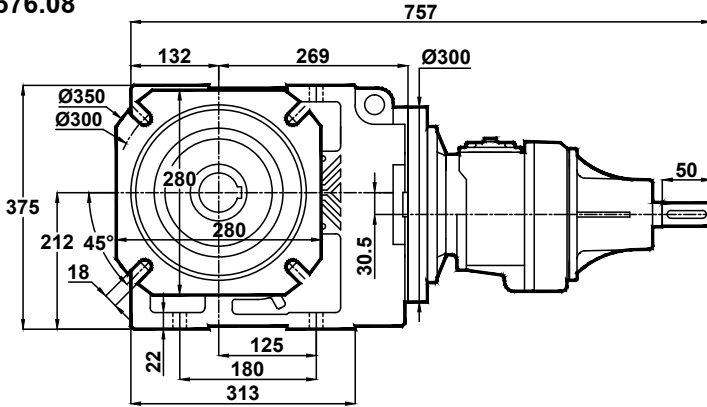



# Ölçü Sayfaları Dimension Pages Abmessungenseiten



-Mil ucu çekirme deliği DIN 332 sayfa 2 / Tapped center hole to DIN 332, sheet 2 / Zentrierung mit gewinde DIN 332, Blatt 2

KT673.00

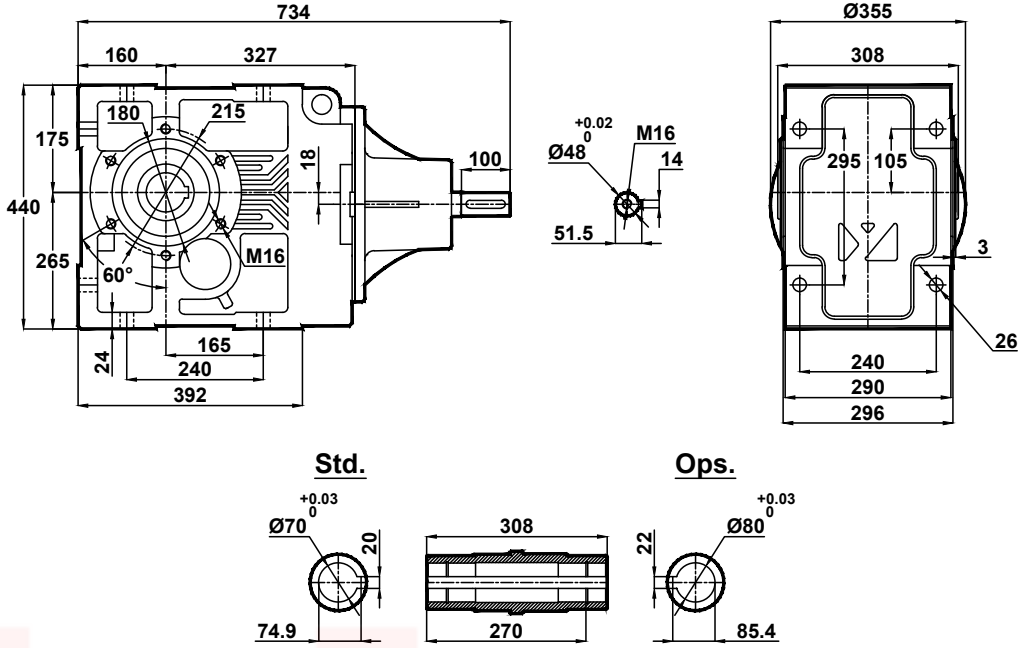

KT673.01

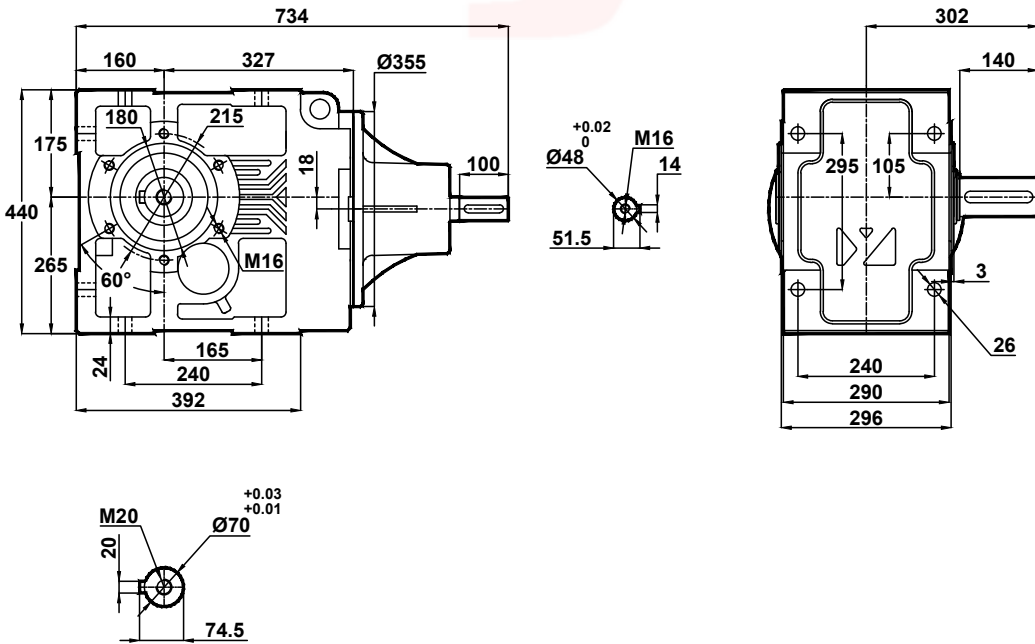



# Ölçü Sayfaları Dimension Pages Abmessungsseiten



-Mil ucu çekirme deliği DIN 332 sayfa 2 / Tapped center hole to DIN 332, sheet 2 / Zentrierung mit gewinde DIN 332, Blatt 2

KT673.02

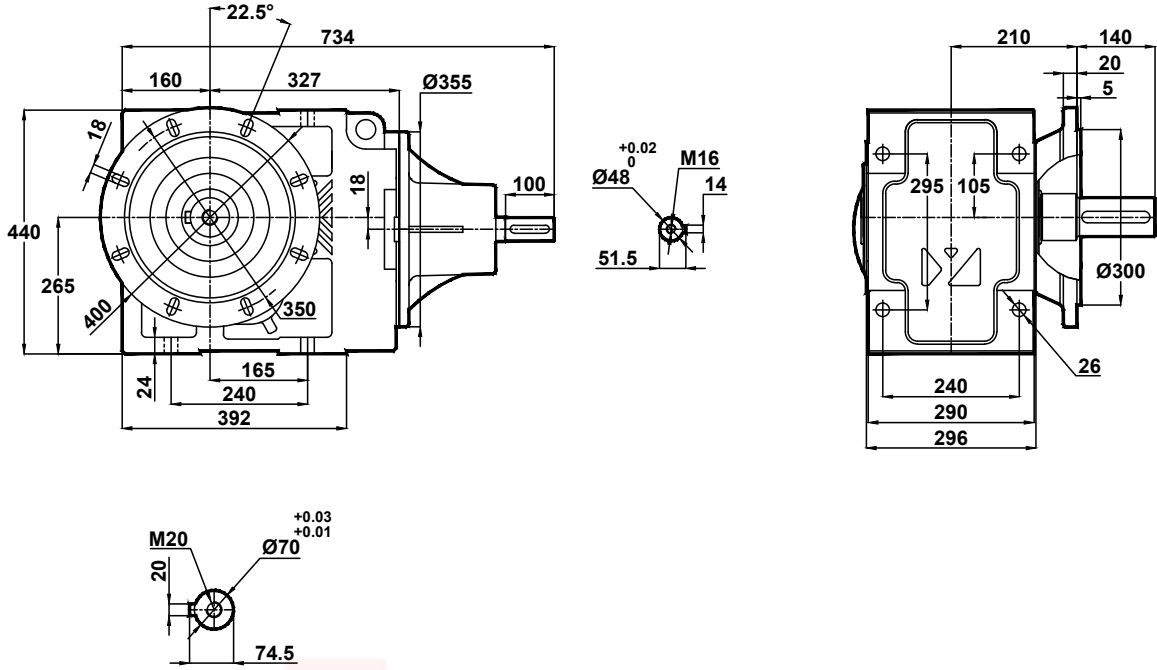

KT673.03

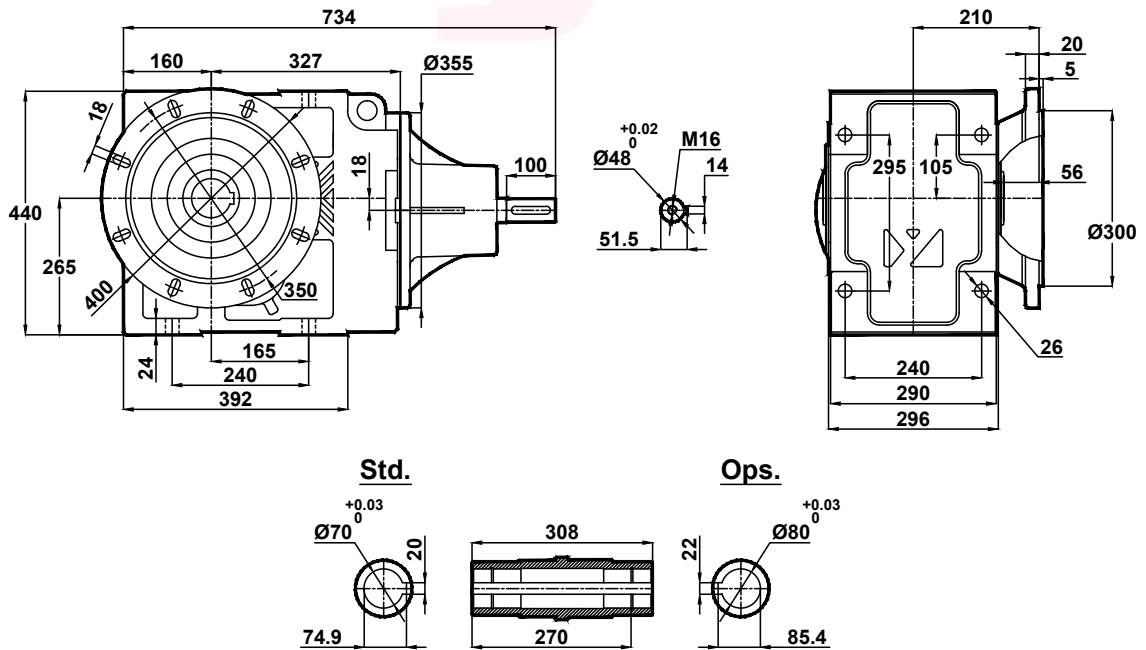



# Ölçü Sayfaları Dimension Pages Abmessungsseiten



-Mil ucu çekirme deliği DIN 332 sayfa 2 / Tapped center hole to DIN 332, sheet 2 / Zentrierung mit gewinde DIN 332, Blatt 2

## KT673.04

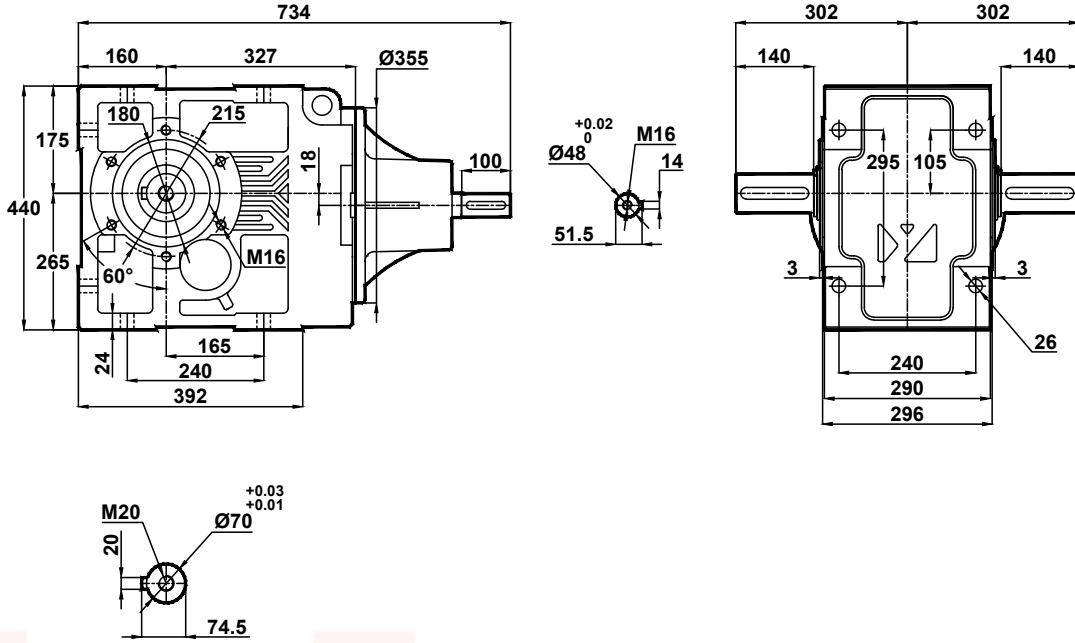

## KT673.05

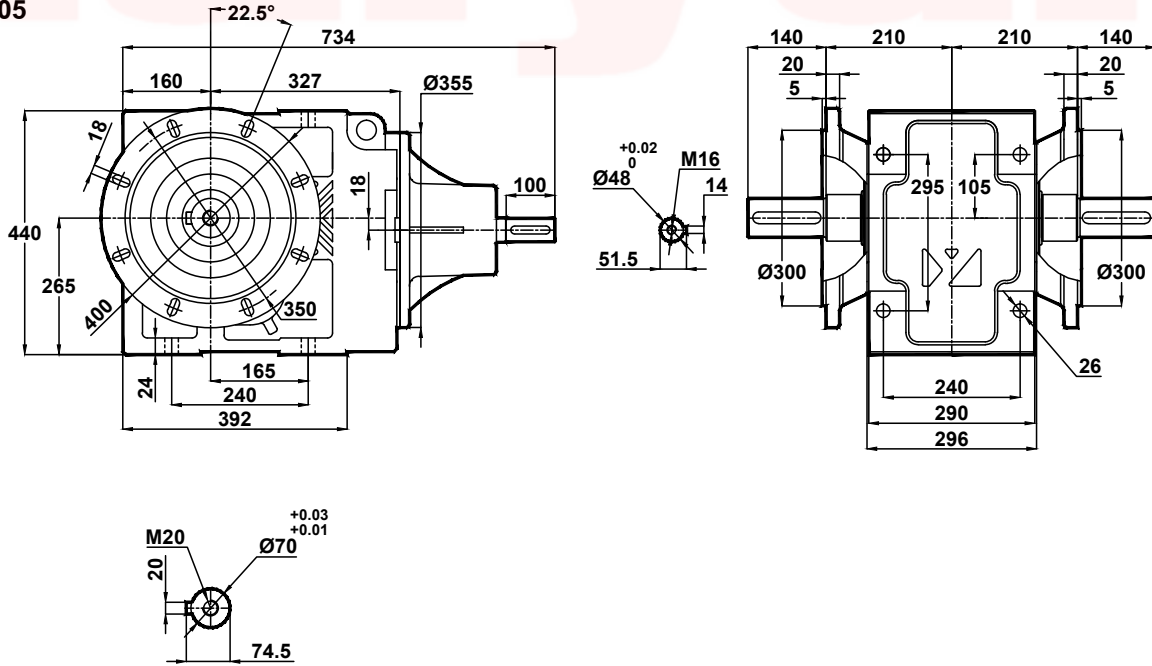





# Ölçü Sayfaları Dimension Pages Abmessungenseiten



-Mil ucu çekirme deliği DIN 332 sayfa 2 / Tapped center hole to DIN 332, sheet 2 / Zentrierung mit gewinde DIN 332, Blatt 2

KT673.08

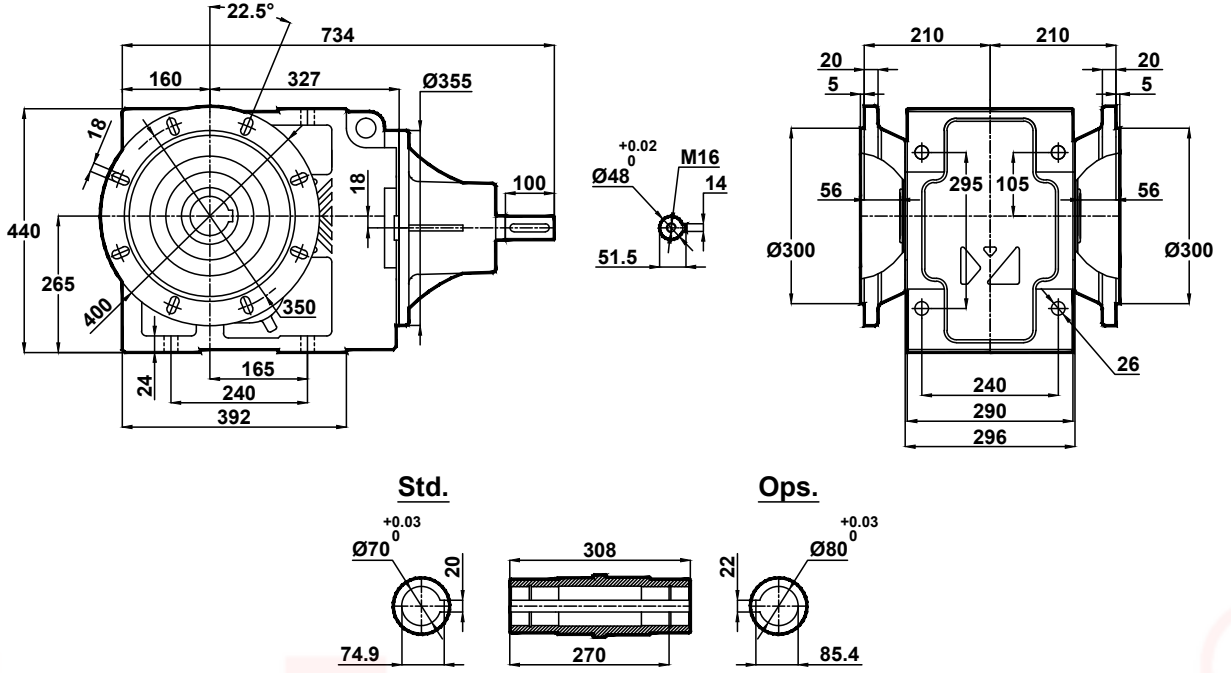



# Ölçü Sayfaları Dimension Pages Abmessungenseiten



-Mil ucu çektirme deliği DIN 332 sayfa 2 / Tapped center hole to DIN 332, sheet 2 / Zentrierung mit gewinde DIN 332, Blatt 2

KT674.00

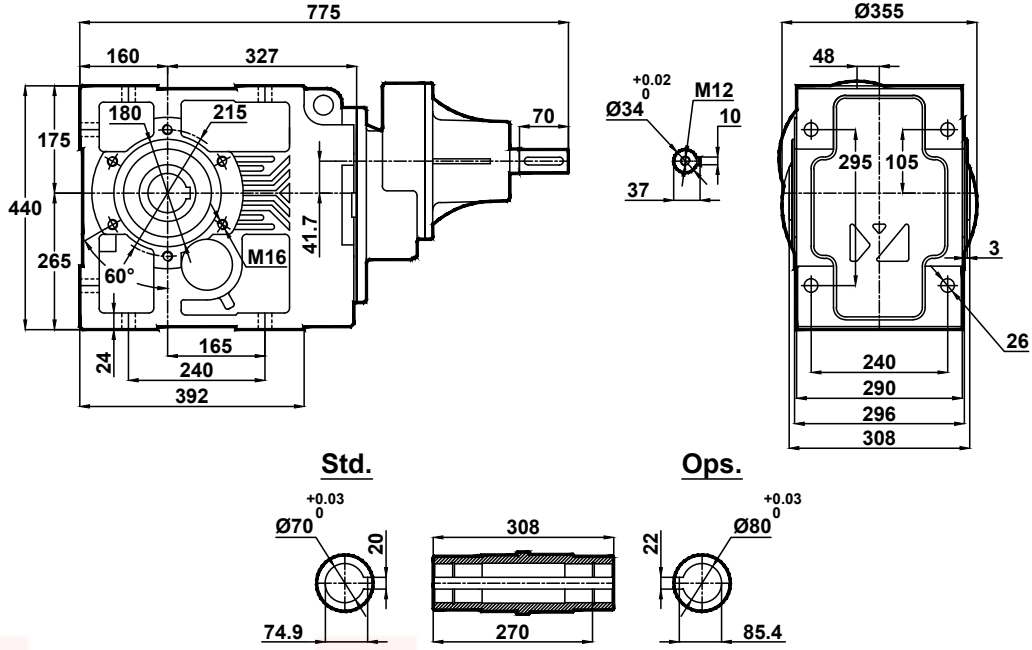

KT674.01

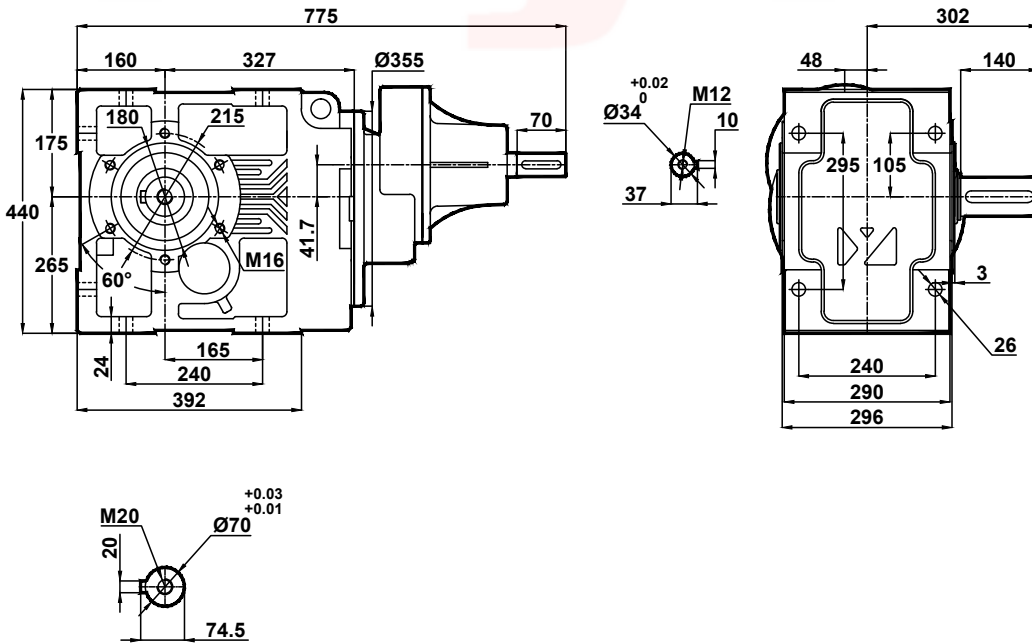



# Ölçü Sayfaları

## Dimension Pages

### Abmessungsseiten



-Mil ucu çekirme deliği DIN 332 sayfa 2 / Tapped center hole to DIN 332, sheet 2 / Zentrierung mit gewinde DIN 332, Blatt 2

KT674.02

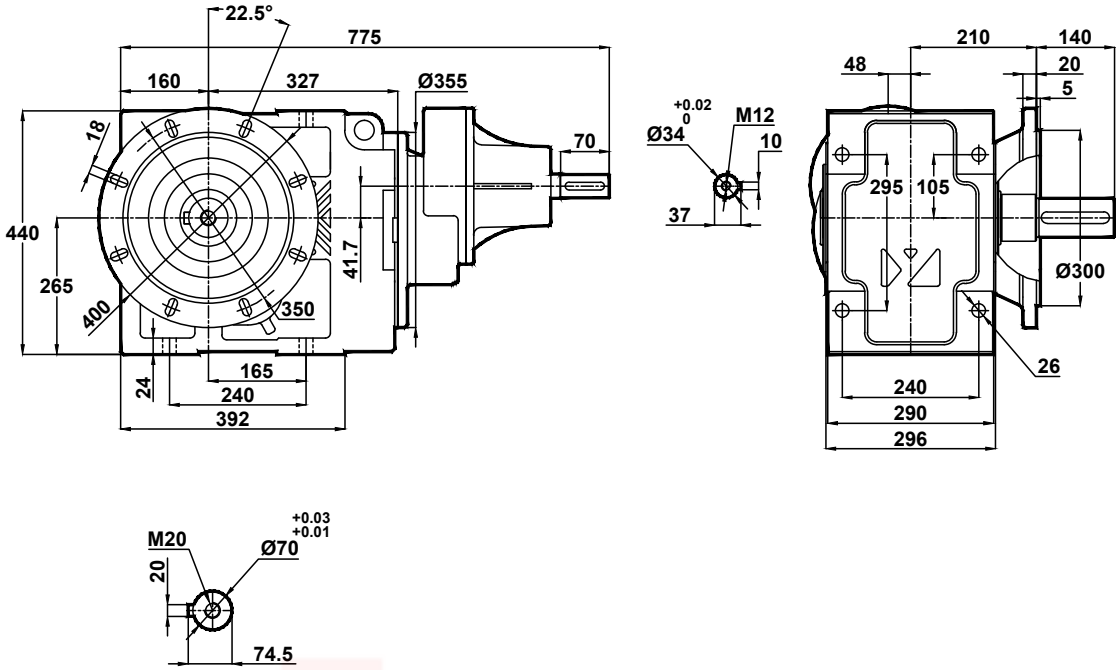

KT674.03

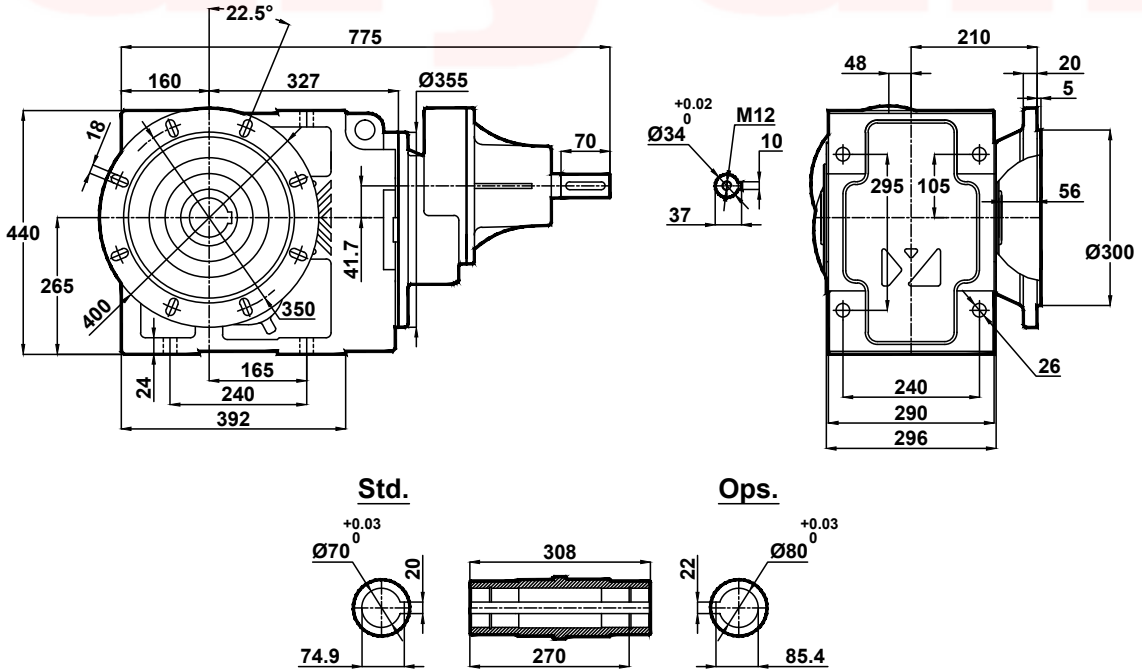



# Ölçü Sayfaları Dimension Pages Abmessungenseiten



-Mil ucu çektirme deliği DIN 332 sayfa 2 / Tapped center hole to DIN 332, sheet 2 / Zentrierung mit gewinde DIN 332, Blatt 2

## KT674.04

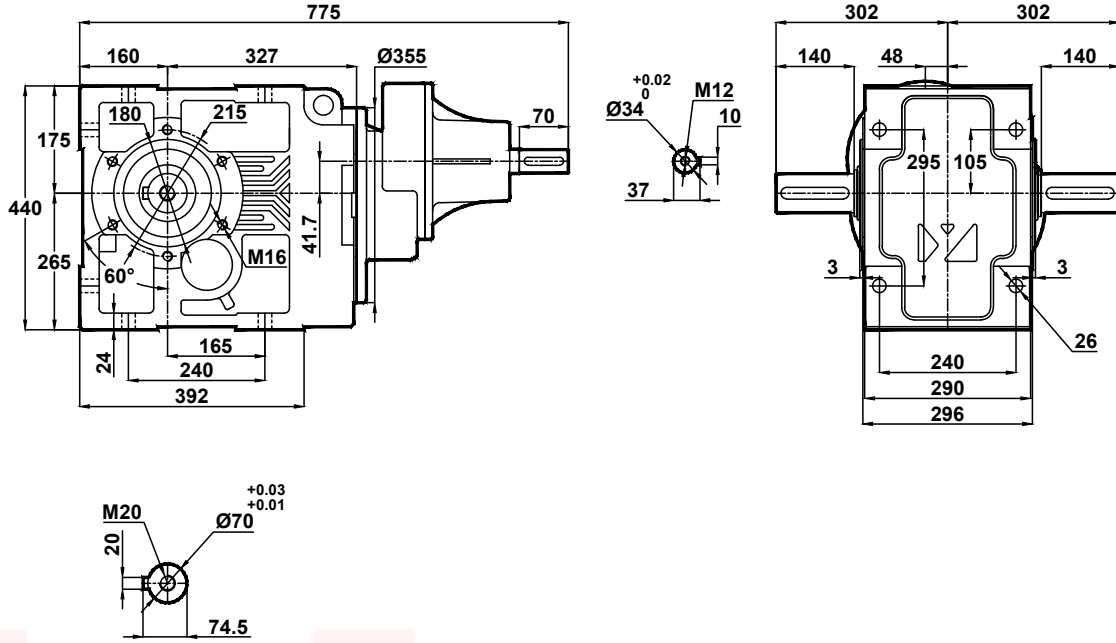

## KT674.05

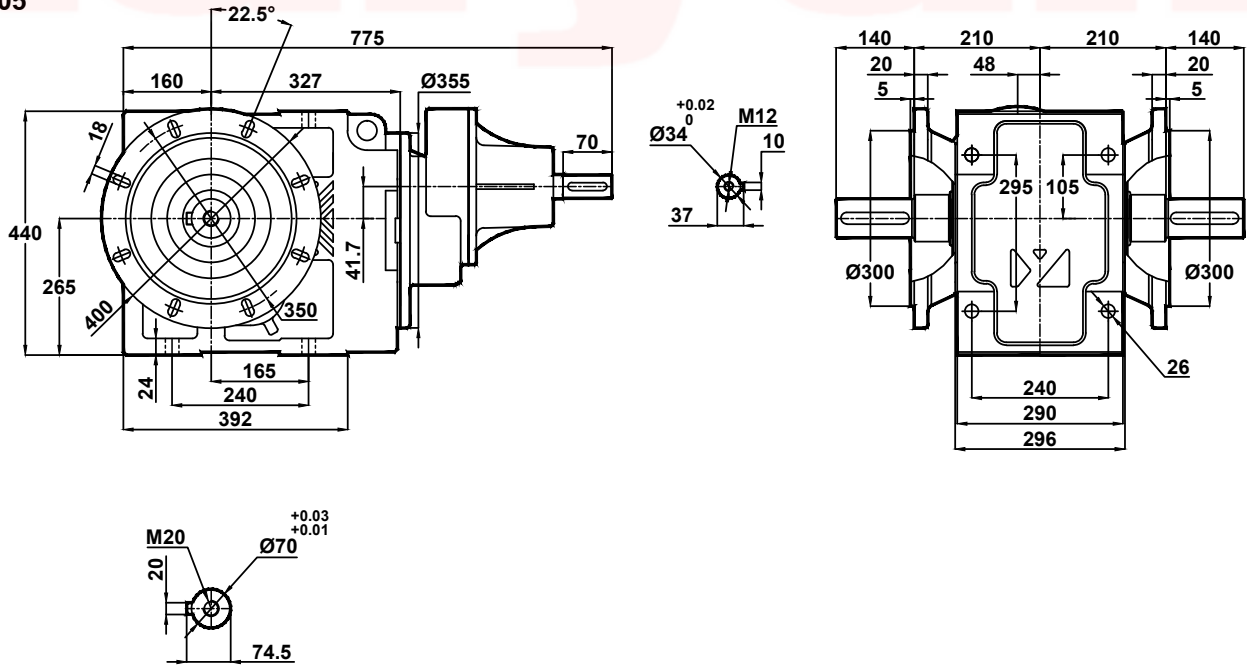



# Ölçü Sayfaları Dimension Pages Abmessungenseiten



-Mil ucu çekirme deliği DIN 332 sayfa 2 / Tapped center hole to DIN 332, sheet 2 / Zentrierung mit gewinde DIN 332, Blatt 2

KT674.08

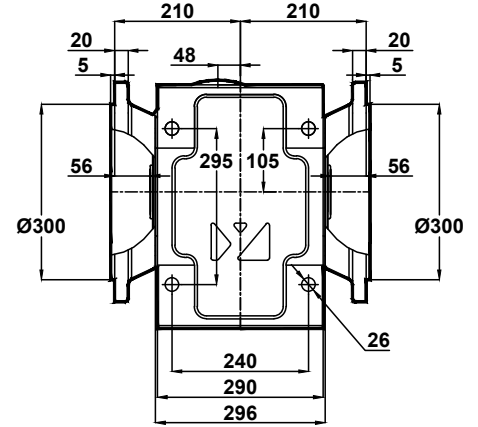
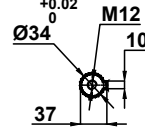
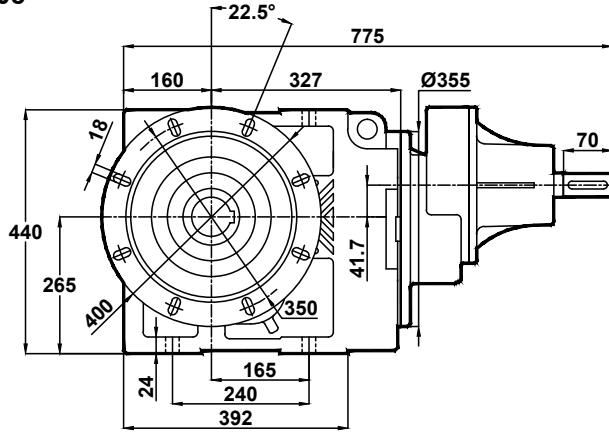

**Std.**

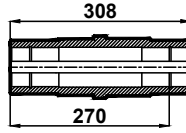
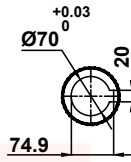

**Ops.**

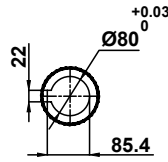



# Ölçü Sayfaları Dimension Pages Abmessungenseiten



-Mil ucu çekirme deliği DIN 332 sayfa 2 / Tapped center hole to DIN 332, sheet 2 / Zentrierung mit gewinde DIN 332, Blatt 2

KT675.00  
KT676.00

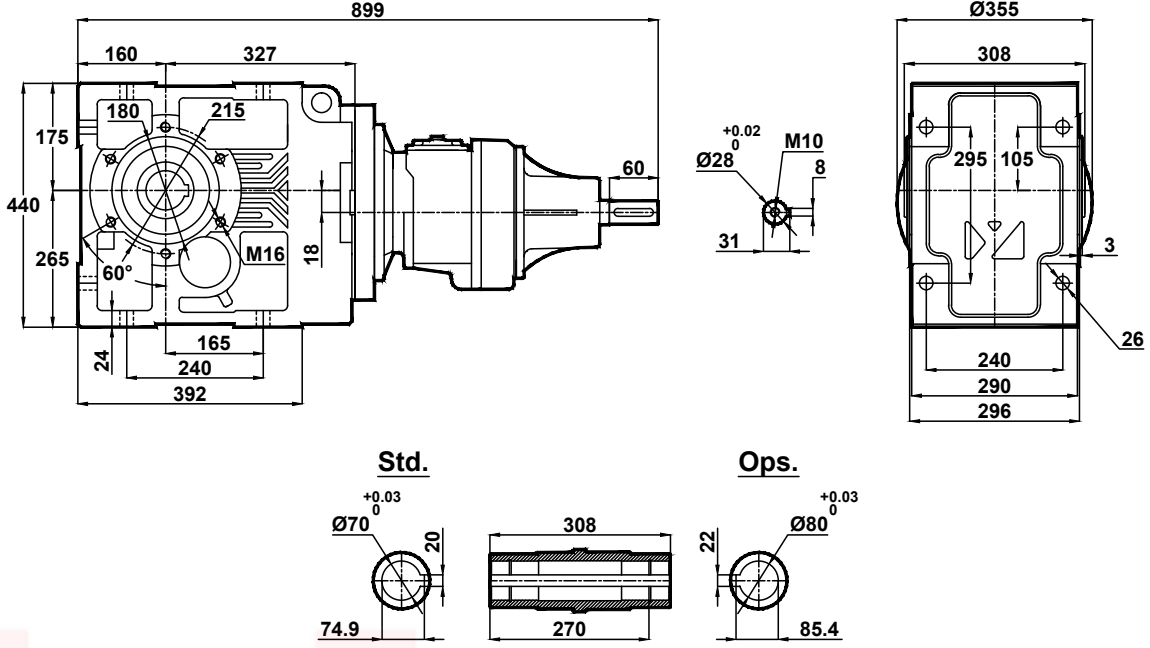

KT675.01  
KT676.01

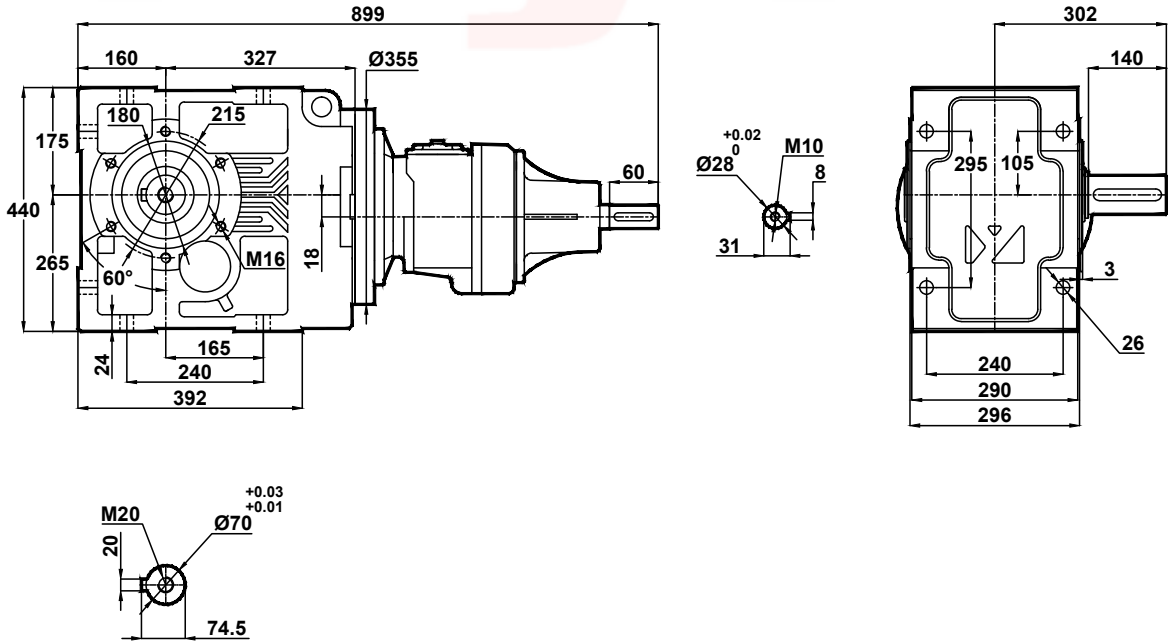



# Ölçü Sayfaları Dimension Pages Abmessungenseiten



-Mil ucu çekirme deliği DIN 332 sayfa 2 / Tapped center hole to DIN 332, sheet 2 / Zentrierung mit gewinde DIN 332, Blatt 2

KT675.02  
KT676.02

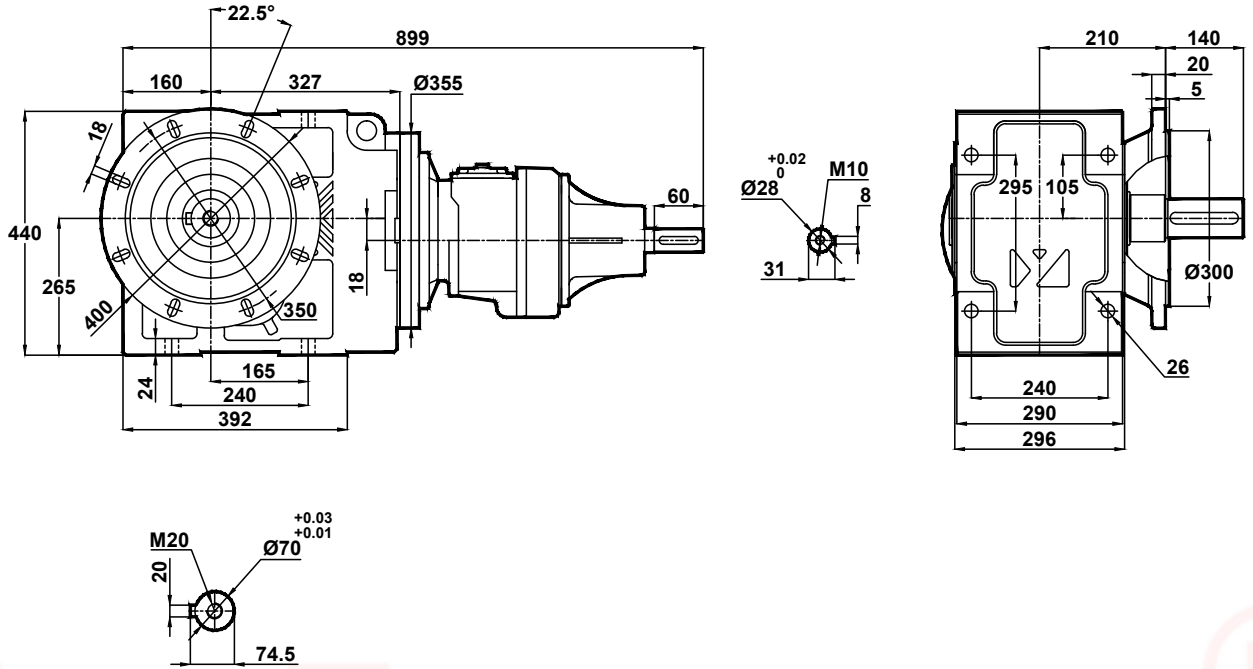

KT675.03  
KT676.03

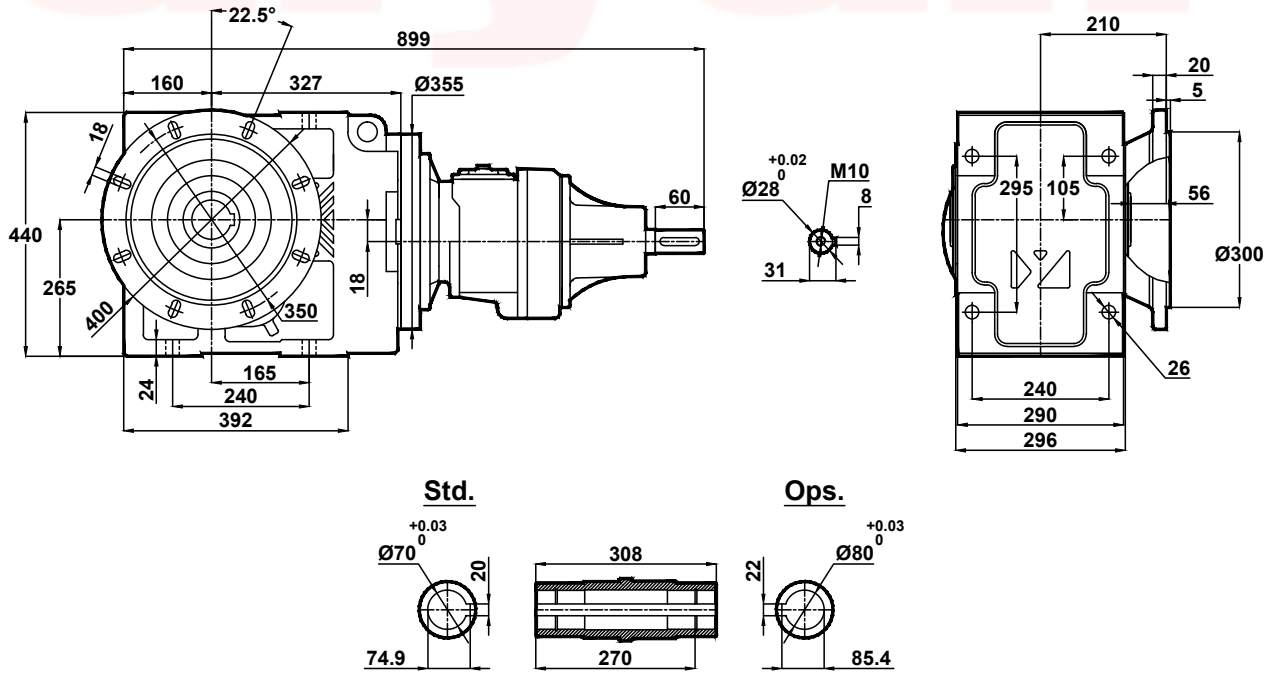



# Ölçü Sayfaları Dimension Pages Abmessungsseiten



-Mil ucu çektirme deliği DIN 332 sayfa 2 / Tapped center hole to DIN 332, sheet 2 / Zentrierung mit gewinde DIN 332, Blatt 2

KT675.04  
KT676.04

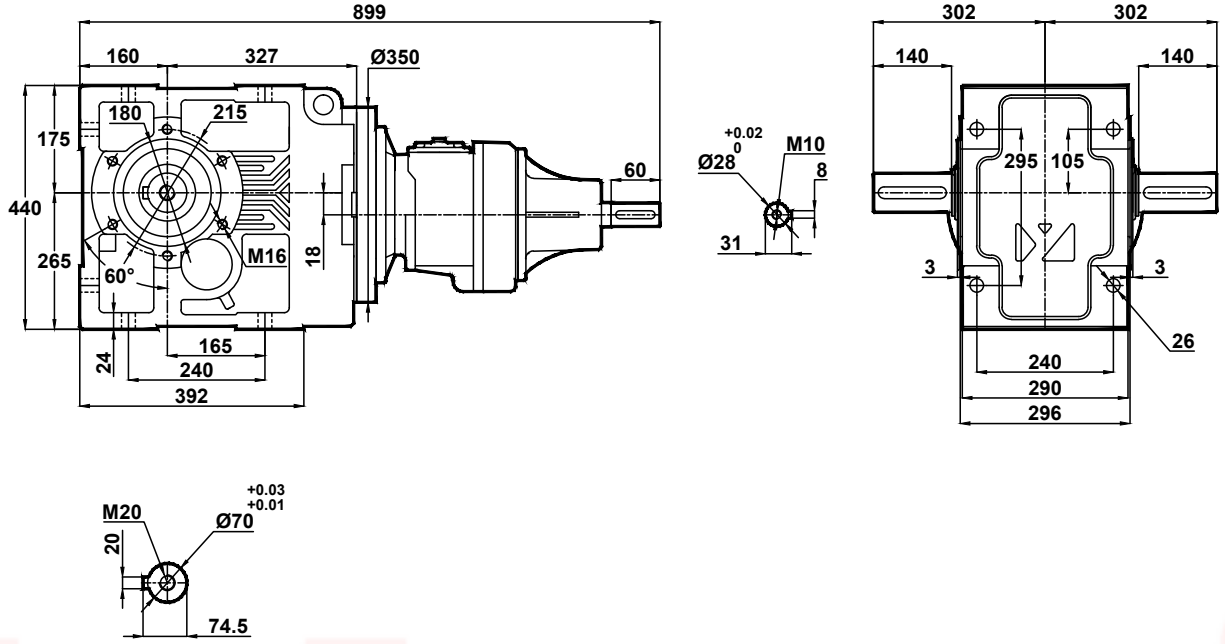

KT675.05  
KT676.05

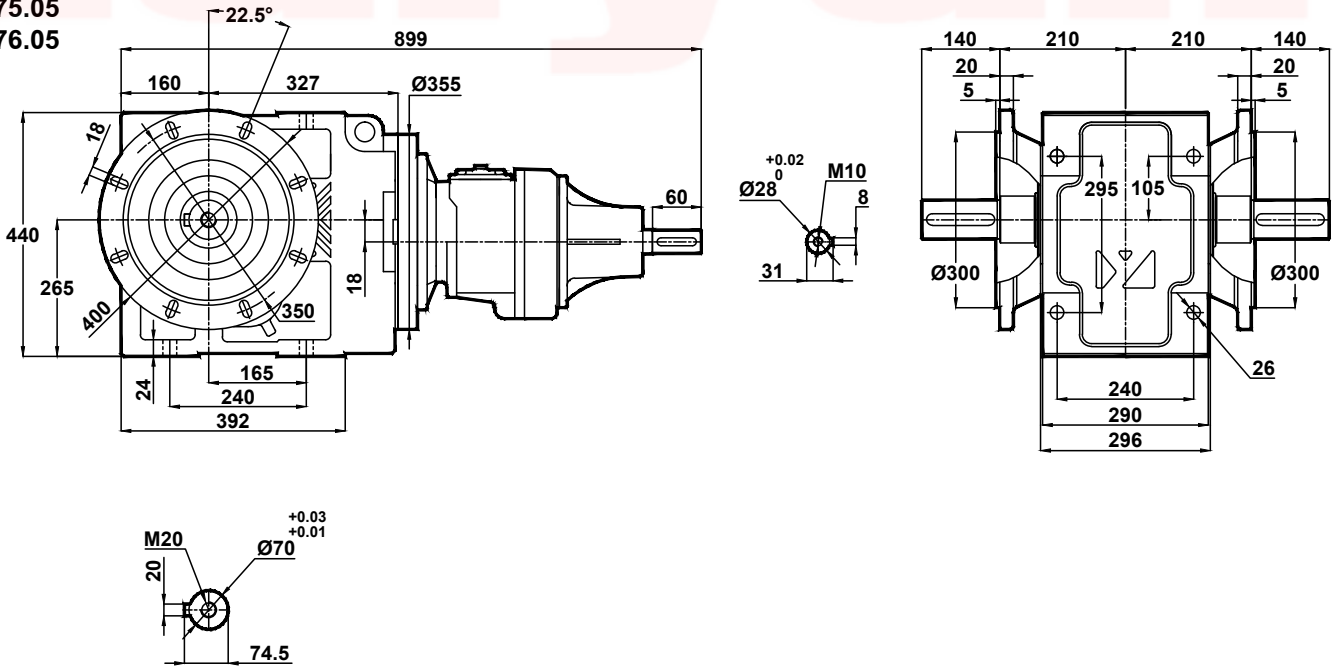





# Ölçü Sayfaları Dimension Pages Abmessungenseiten



-Mil ucu çekirme deliği DIN 332 sayfa 2 / Tapped center hole to DIN 332, sheet 2 / Zentrierung mit gewinde DIN 332, Blatt 2

KT675.08  
KT676.08

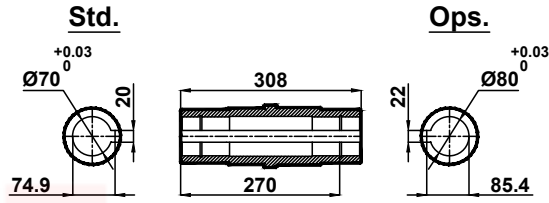
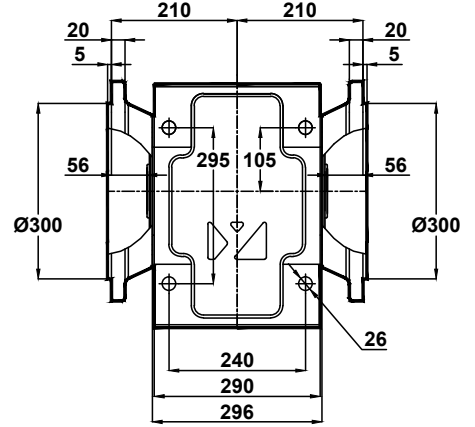
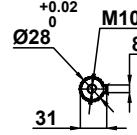
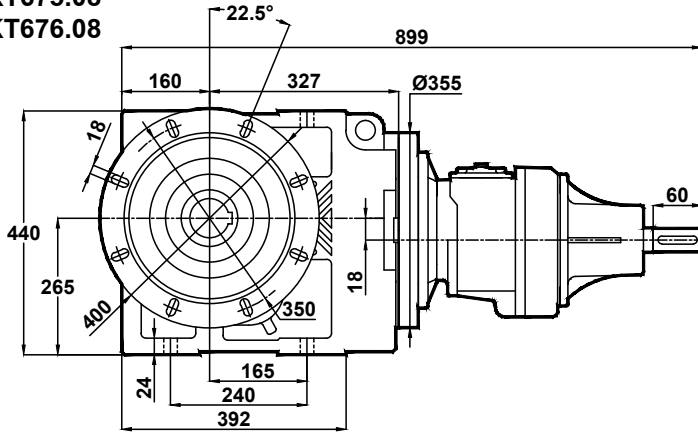



# Ölçü Sayfaları Dimension Pages Abmessungenseiten



-Mil ucu çektirme deliği DIN 332 sayfa 2 / Tapped center hole to DIN 332, sheet 2 / Zentrierung mit gewinde DIN 332, Blatt 2

KT773.00

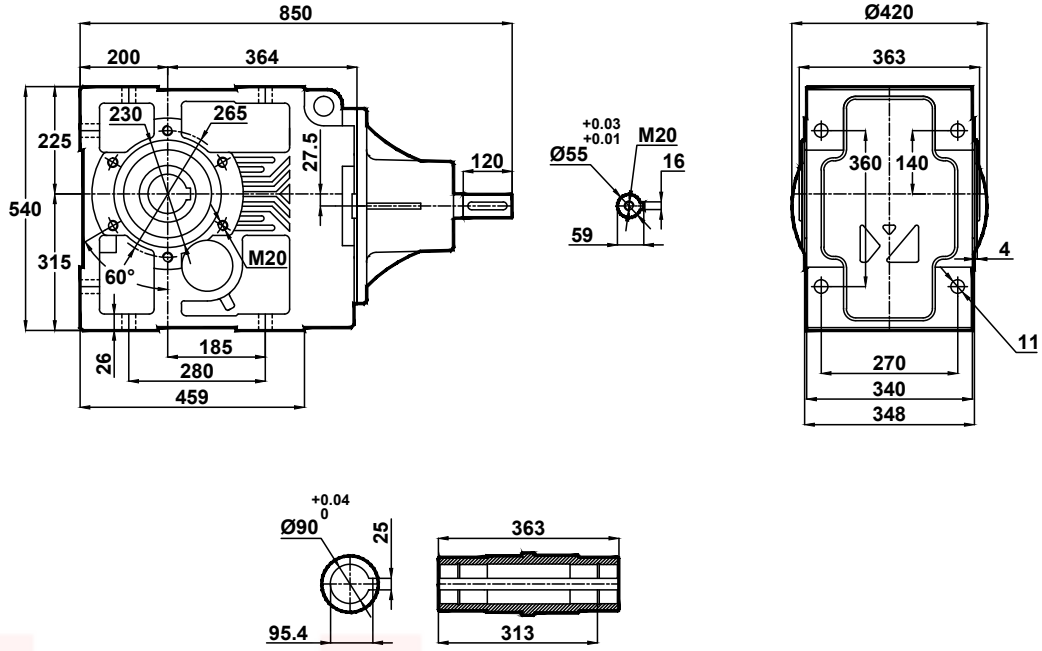

KT773.01

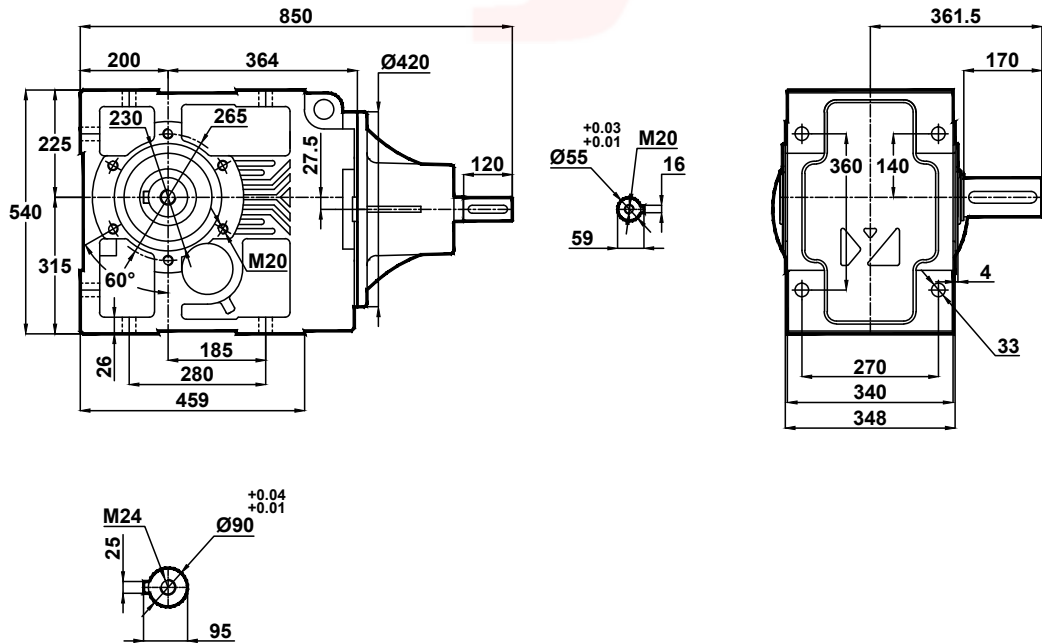



# Ölçü Sayfaları Dimension Pages Abmessungenseiten



-Mil ucu çekirme deliği DIN 332 sayfa 2 / Tapped center hole to DIN 332, sheet 2 / Zentrierung mit gewinde DIN 332, Blatt 2

KT773.02

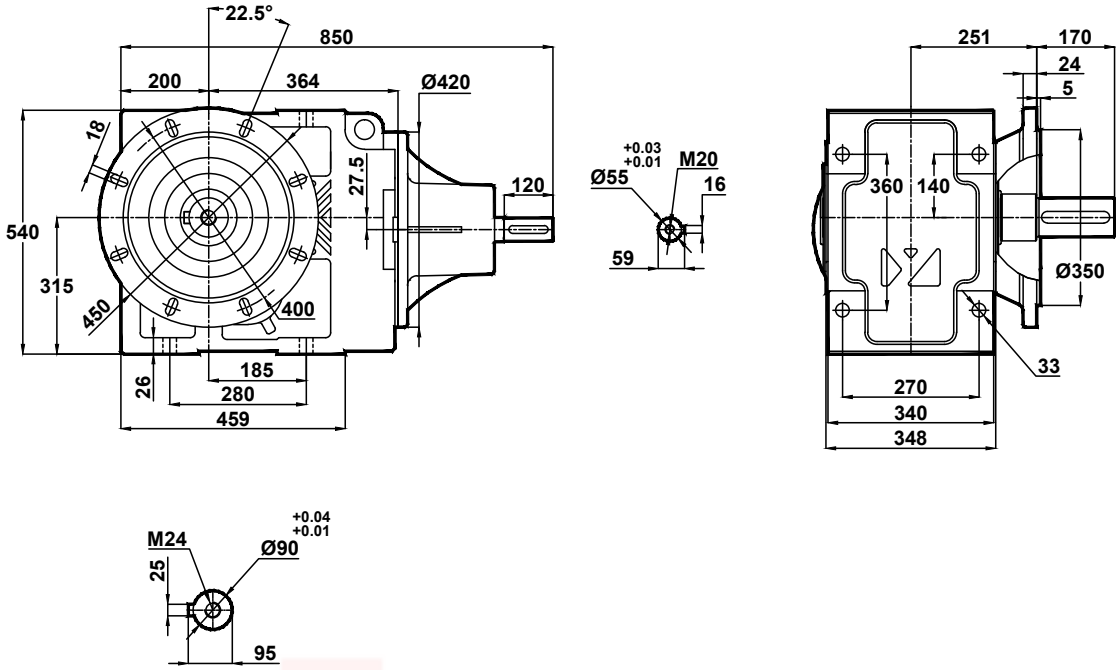

KT773.03

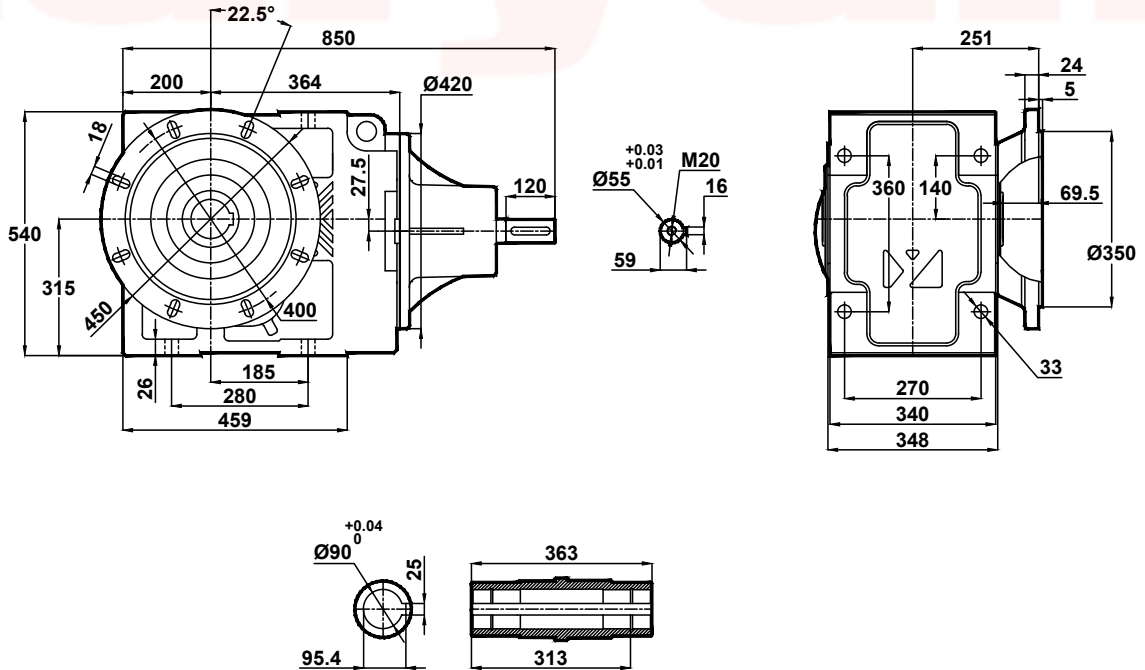



# Ölçü Sayfaları Dimension Pages Abmessungenseiten



-Mil ucu çektirme deliği DIN 332 sayfa 2 / Tapped center hole to DIN 332, sheet 2 / Zentrierung mit gewinde DIN 332, Blatt 2

KT773.04

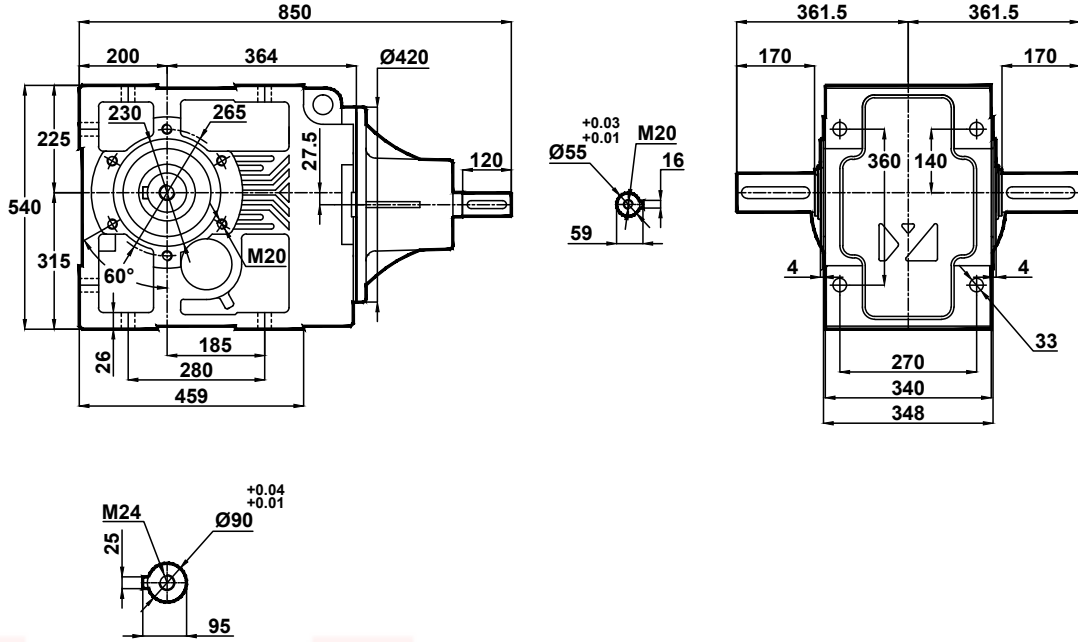

KT773.05

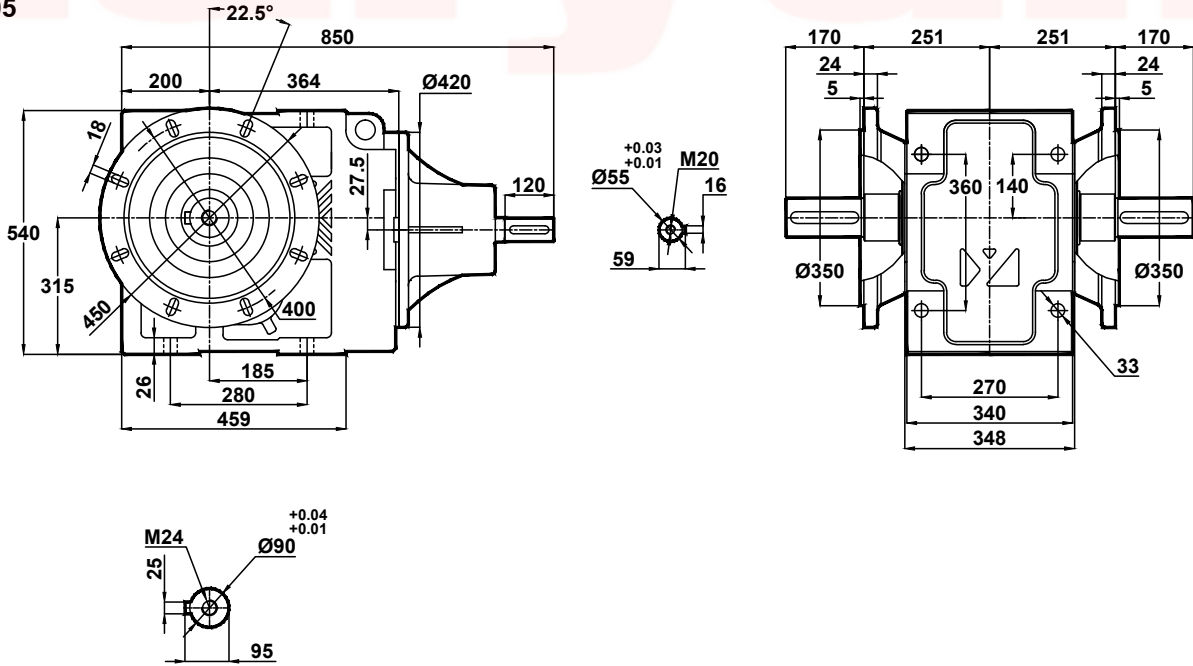



# Ölçü Sayfaları Dimension Pages Abmessungenseiten



-Mil ucu çekirme deliği DIN 332 sayfa 2 / Tapped center hole to DIN 332, sheet 2 / Zentrierung mit gewinde DIN 332, Blatt 2

KT773.08

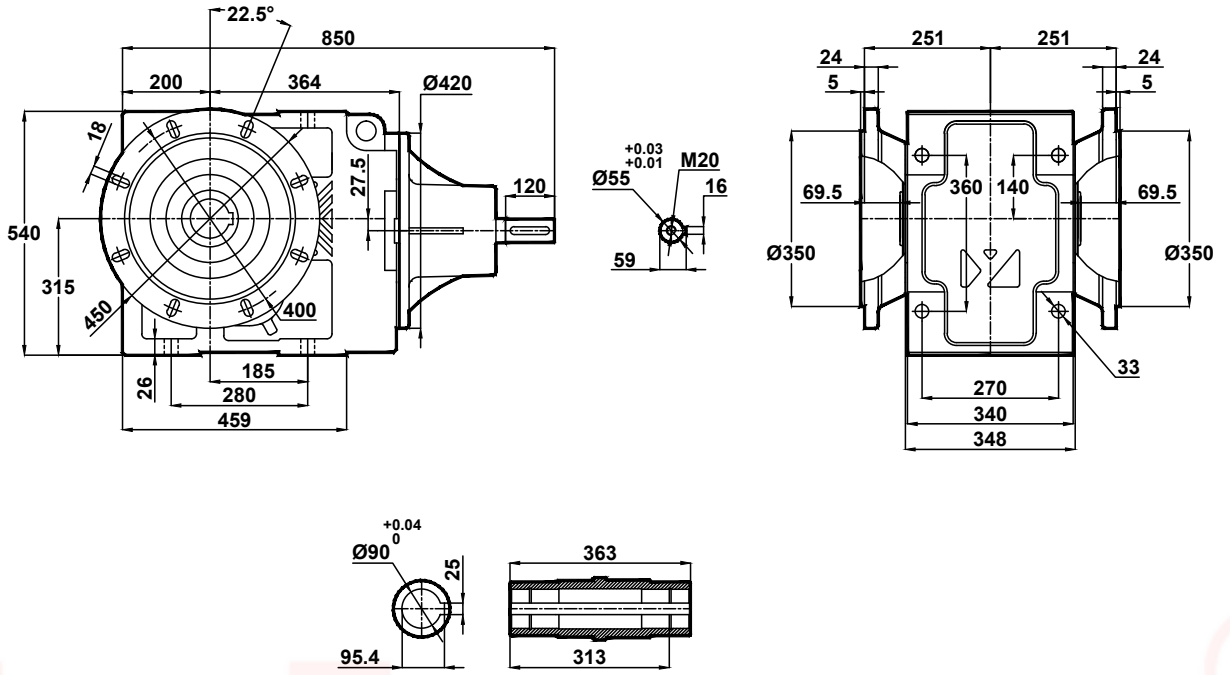



# Ölçü Sayfaları Dimension Pages Abmessungenseiten



-Mil ucu çekirme deliği DIN 332 sayfa 2 / Tapped center hole to DIN 332, sheet 2 / Zentrierung mit gewinde DIN 332, Blatt 2

KT774.00

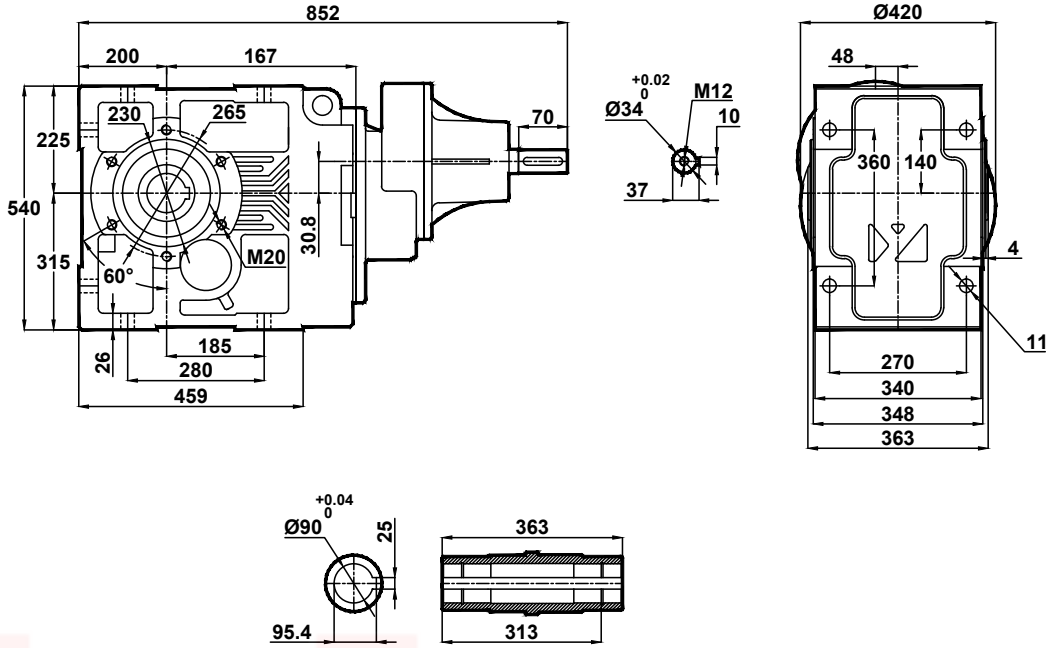

KT774.01

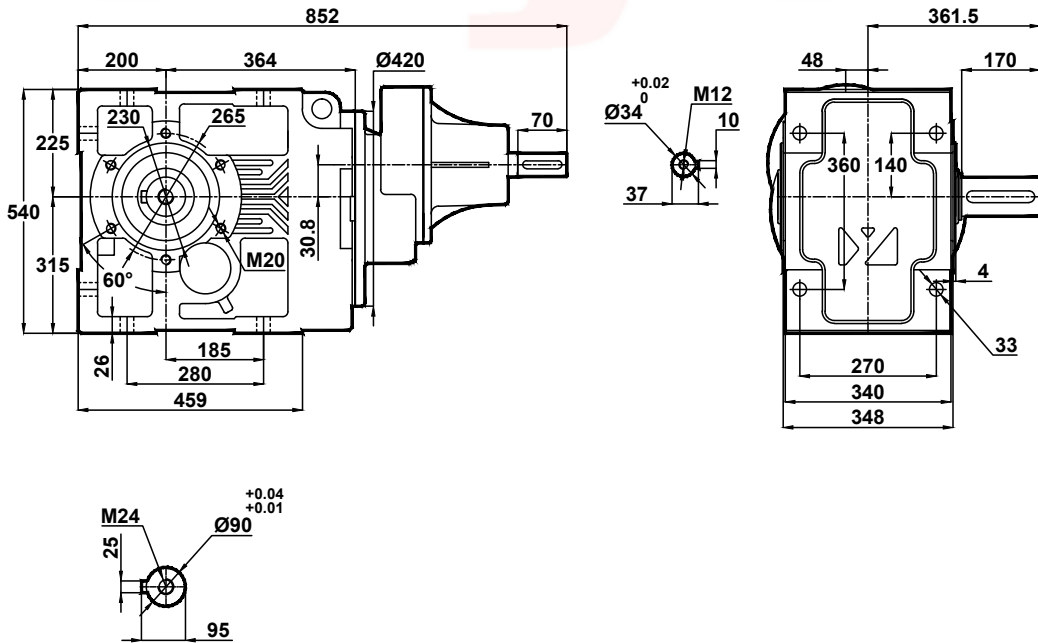



# Ölçü Sayfaları

## Dimension Pages

### Abmessungsseiten



-Mil ucu çekirme deliği DIN 332 sayfa 2 / Tapped center hole to DIN 332, sheet 2 / Zentrierung mit gewinde DIN 332, Blatt 2

KT774.02

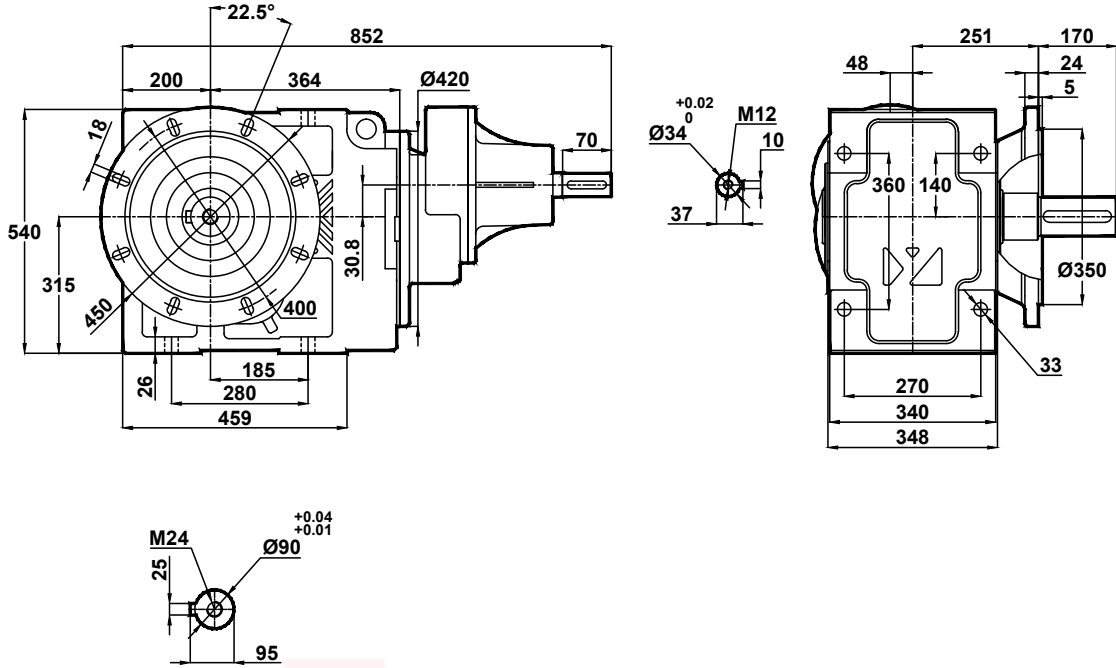

KT774.03

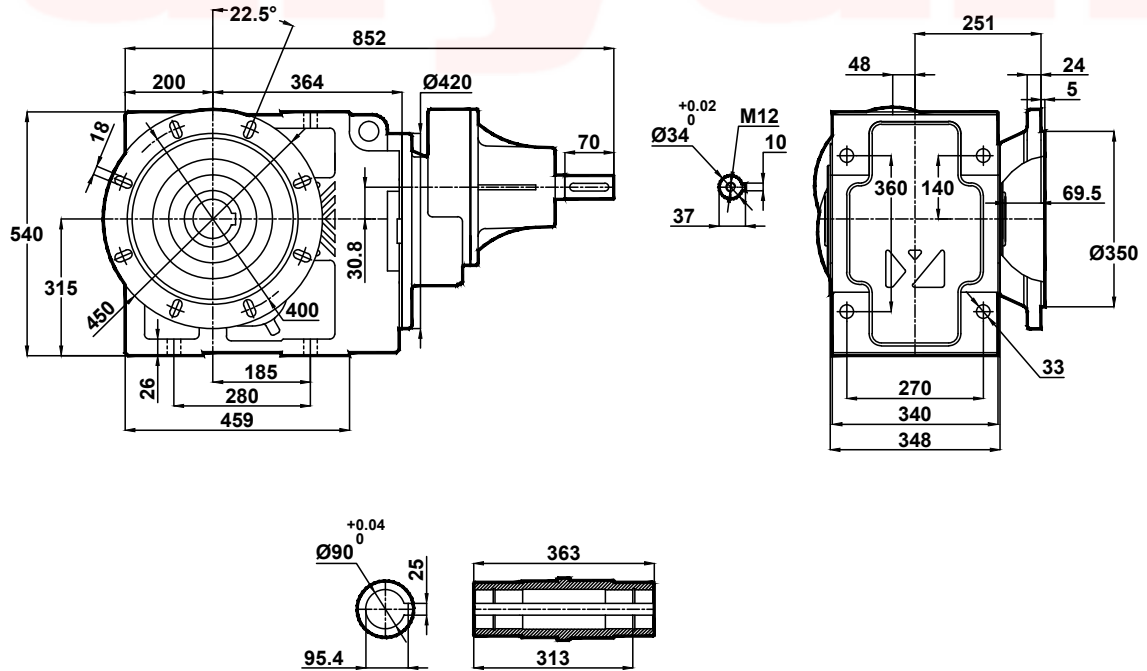



# Ölçü Sayfaları Dimension Pages Abmessungenseiten



-Mil ucu çektirme deliği DIN 332 sayfa 2 / Tapped center hole to DIN 332, sheet 2 / Zentrierung mit gewinde DIN 332, Blatt 2

KT774.04

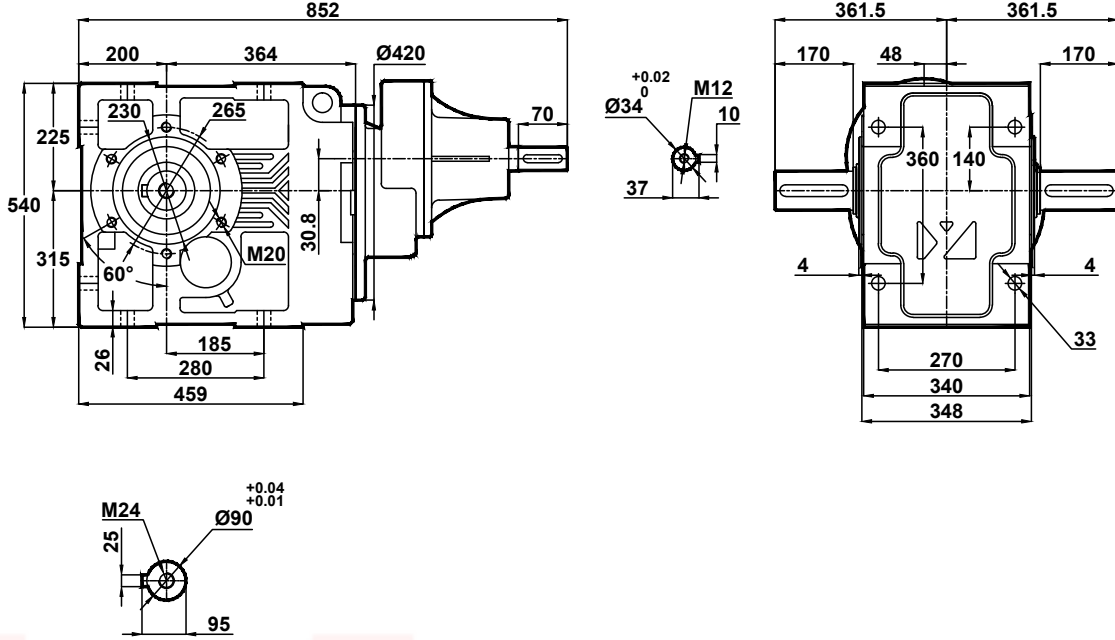

KT774.05

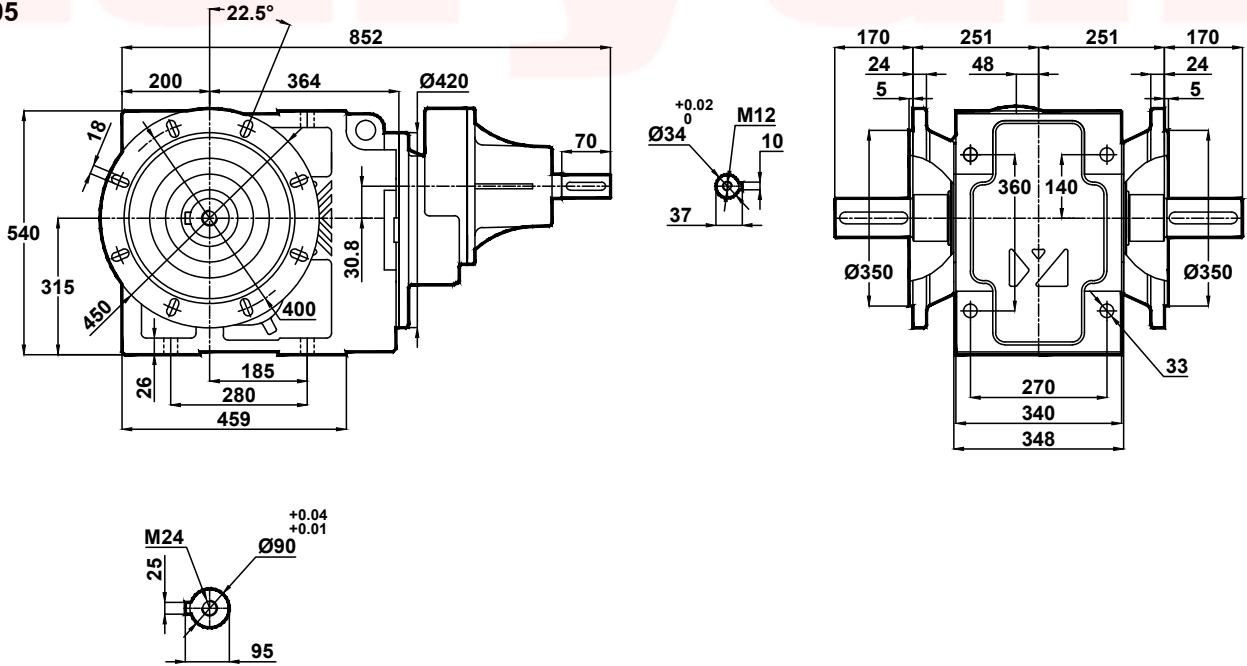





# Ölçü Sayfaları Dimension Pages Abmessungenseiten



-Mil ucu çektirme deliği DIN 332 sayfa 2 / Tapped center hole to DIN 332, sheet 2 / Zentrierung mit gewinde DIN 332, Blatt 2

KT774.08

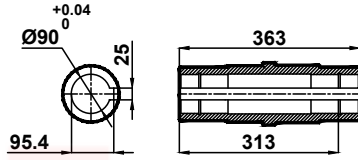
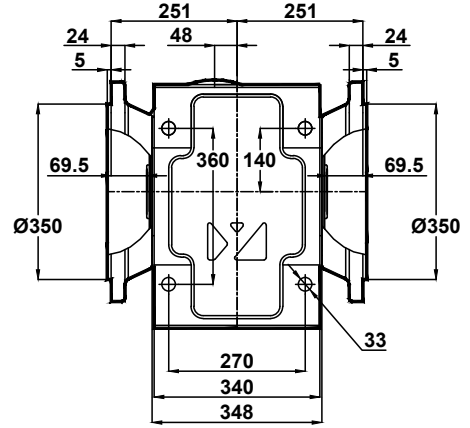
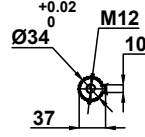
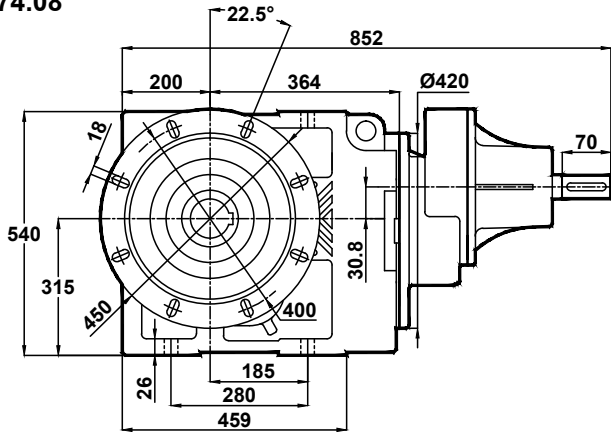



# Ölçü Sayfaları Dimension Pages Abmessungenseiten



-Mil ucu çektirme deliği DIN 332 sayfa 2 / Tapped center hole to DIN 332, sheet 2 / Zentrierung mit gewinde DIN 332, Blatt 2

KT775.00  
KT776.00

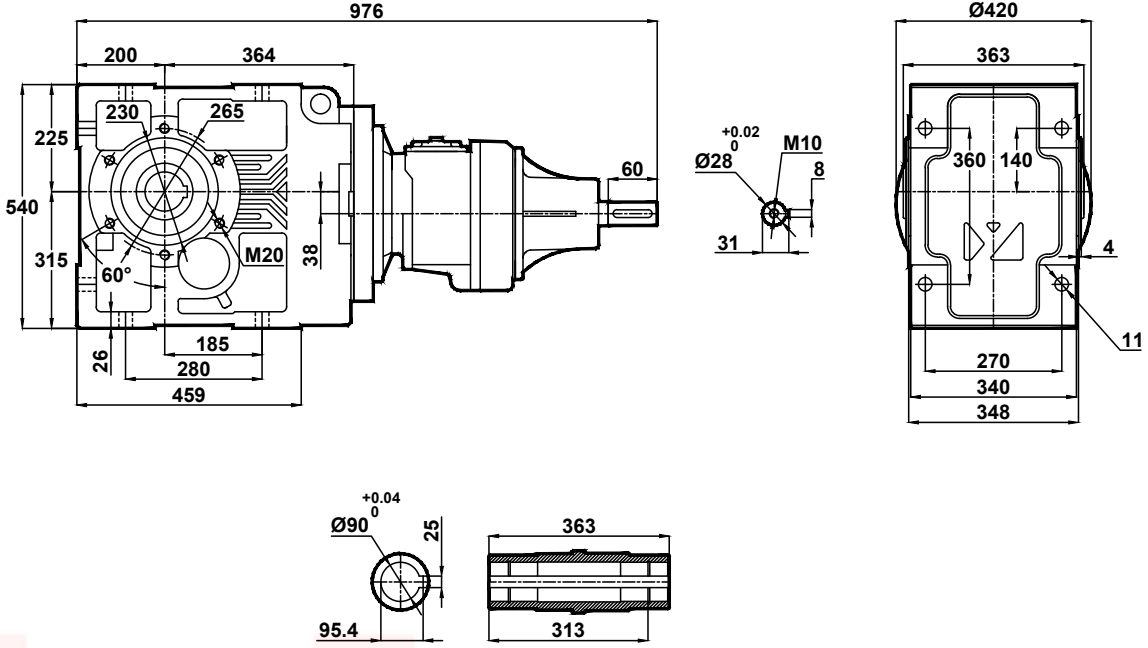

KT775.01  
KT776.01

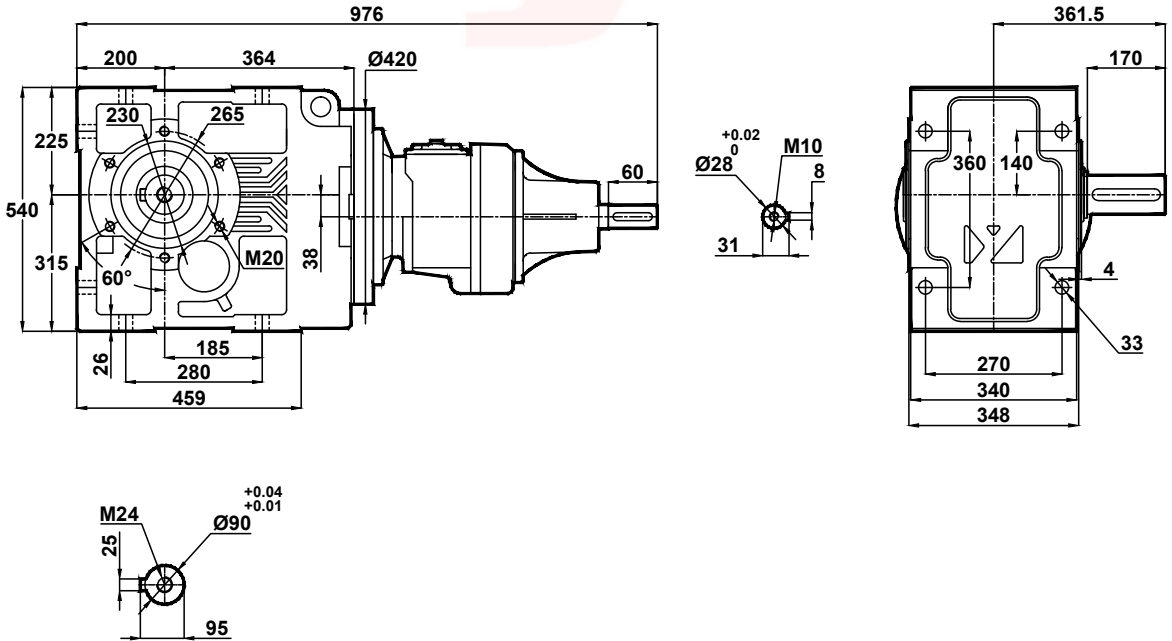



# Ölçü Sayfaları

## Dimension Pages

### Abmessungsseiten



-Mil ucu çekirme deliği DIN 332 sayfa 2 / Tapped center hole to DIN 332, sheet 2 / Zentrierung mit gewinde DIN 332, Blatt 2

KT775.02  
KT776.02

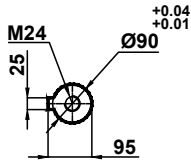
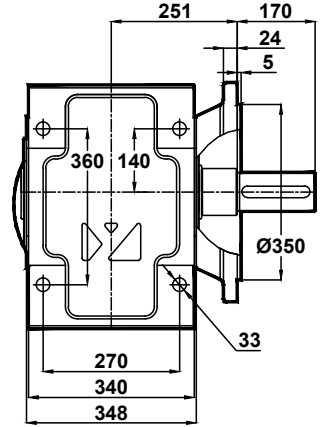
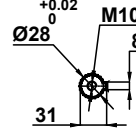
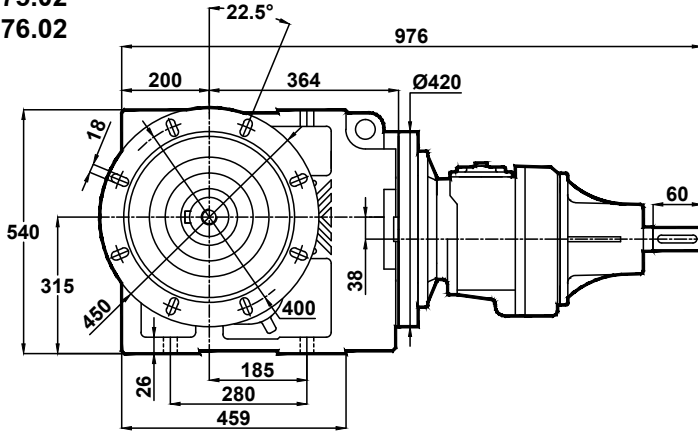

KT775.03  
KT776.03

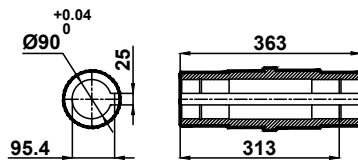
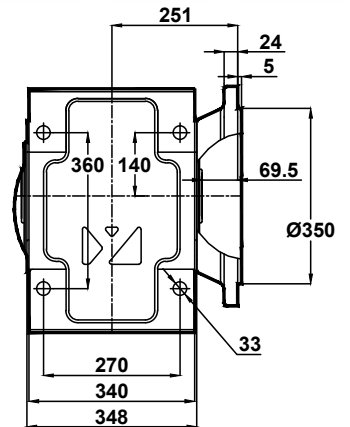
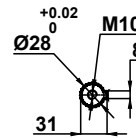
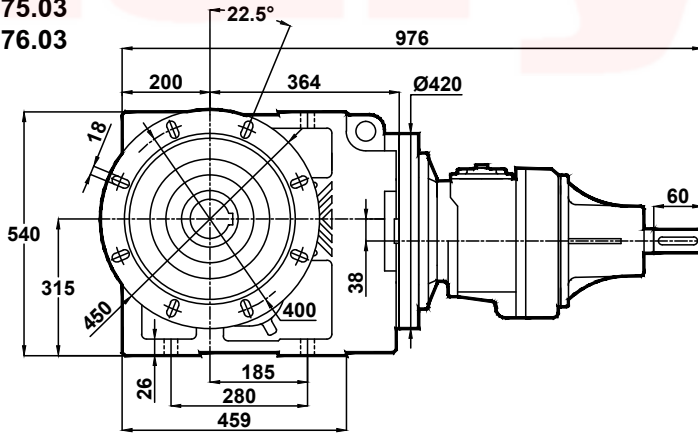



# Ölçü Sayfaları Dimension Pages Abmessungenseiten



-Mil ucu çektirme deliği DIN 332 sayfa 2 / Tapped center hole to DIN 332, sheet 2 / Zentrierung mit gewinde DIN 332, Blatt 2

KT775.04  
KT776.04

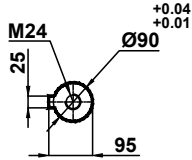
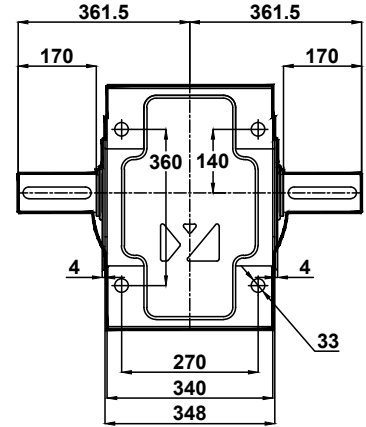
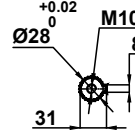
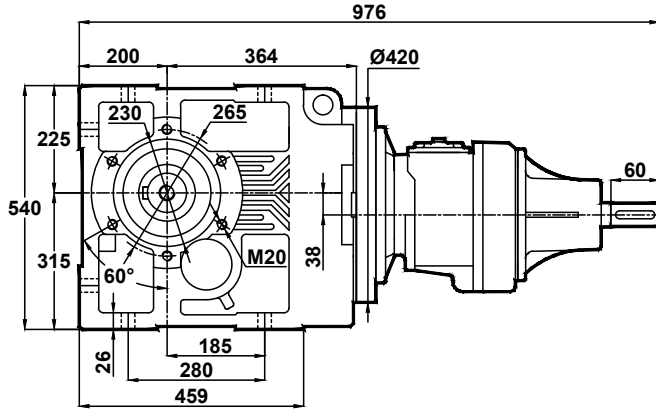

KT775.05  
KT776.05

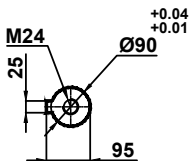
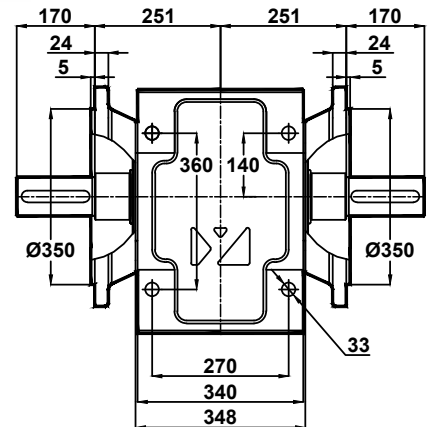
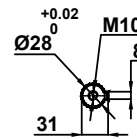
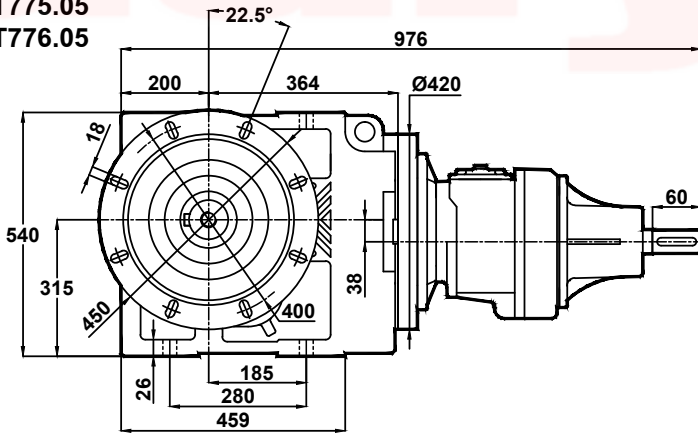



# Ölçü Sayfaları Dimension Pages Abmessungsseiten



-Mil ucu çekirme deliği DIN 332 sayfa 2 / Tapped center hole to DIN 332, sheet 2 / Zentrierung mit gewinde DIN 332, Blatt 2

KT775.08  
KT776.08

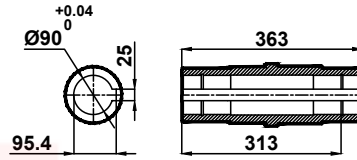
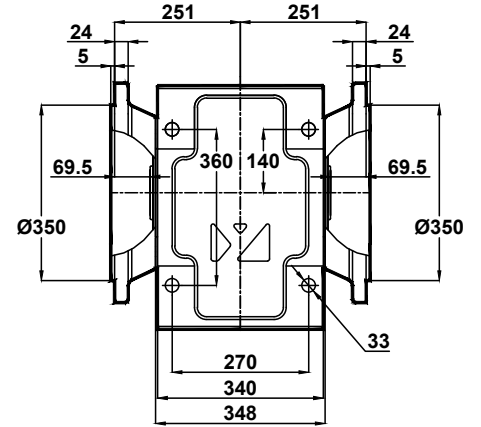
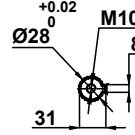
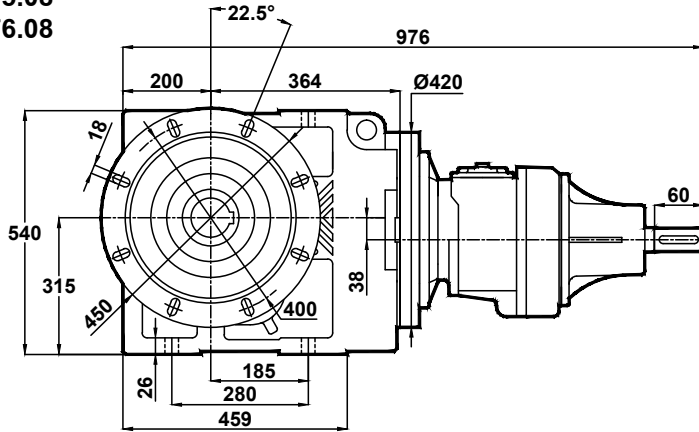



# Ölçü Sayfaları Dimension Pages Abmessungenseiten



-Mil ucu çekirme deliği DIN 332 sayfa 2 / Tapped center hole to DIN 332, sheet 2 / Zentrierung mit gewinde DIN 332, Blatt 2

KT873.00

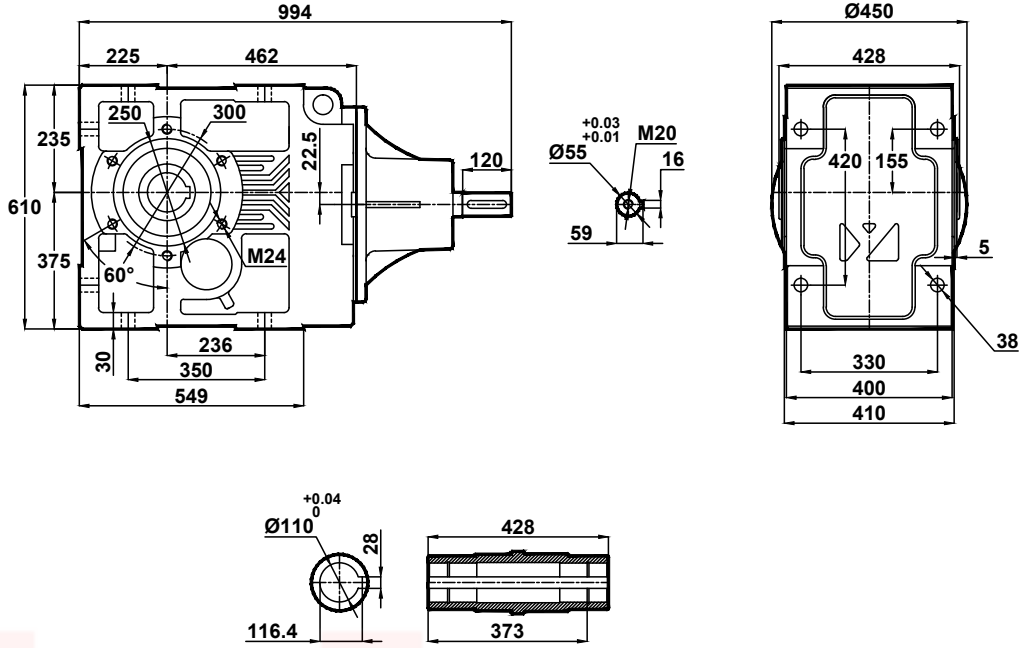

KT873.01

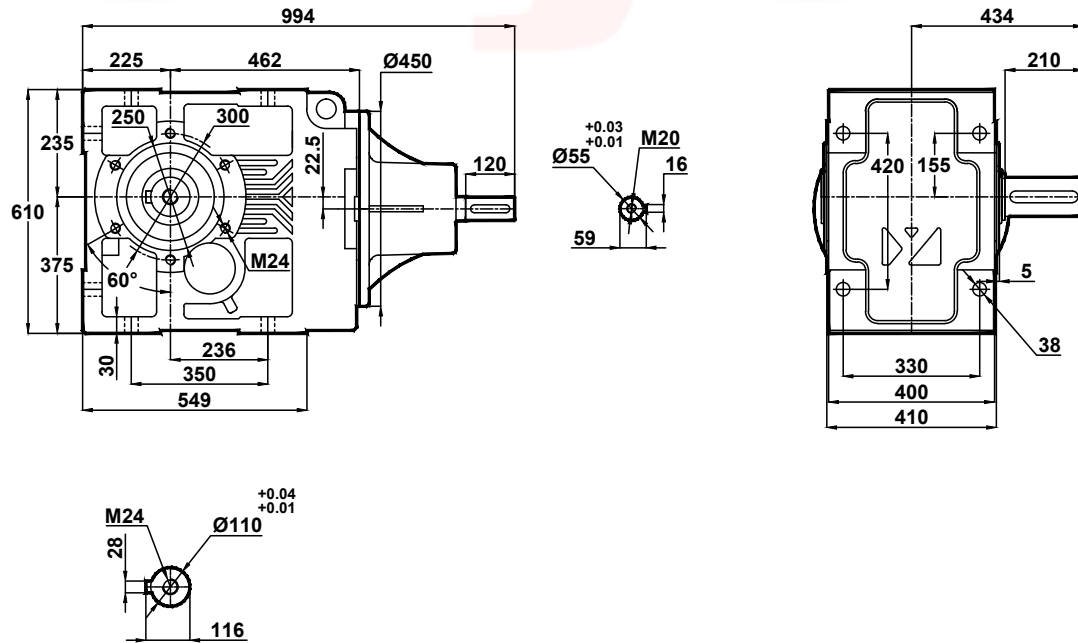



# Ölçü Sayfaları Dimension Pages Abmessungenseiten



-Mil ucu çekirme deliği DIN 332 sayfa 2 / Tapped center hole to DIN 332, sheet 2 / Zentrierung mit gewinde DIN 332, Blatt 2

KT873.02

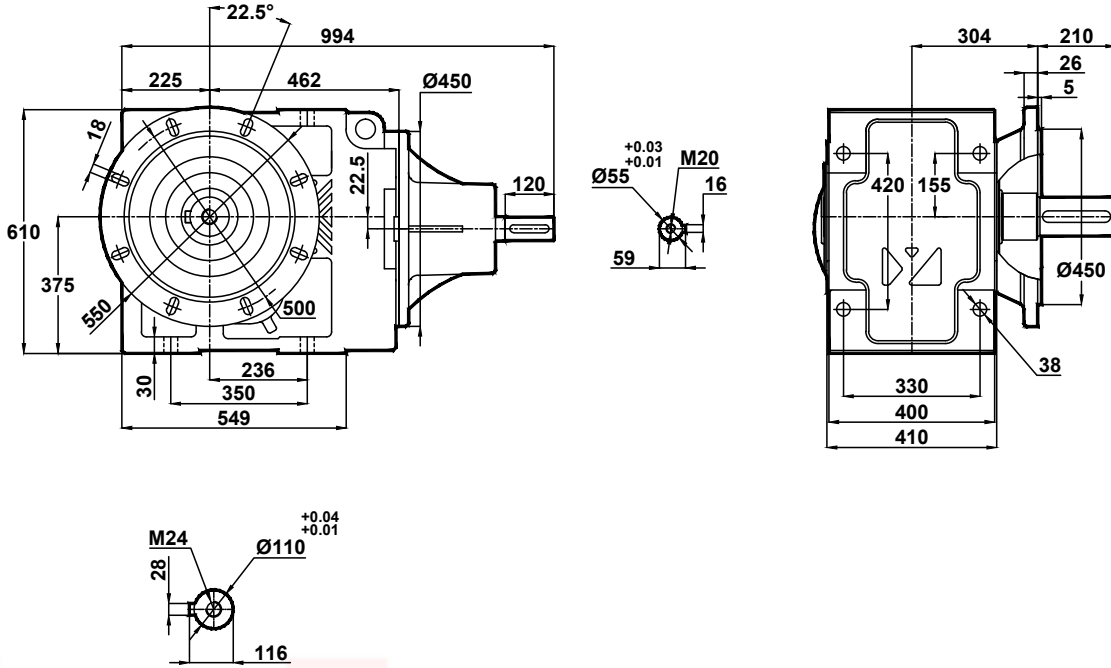

KT873.03

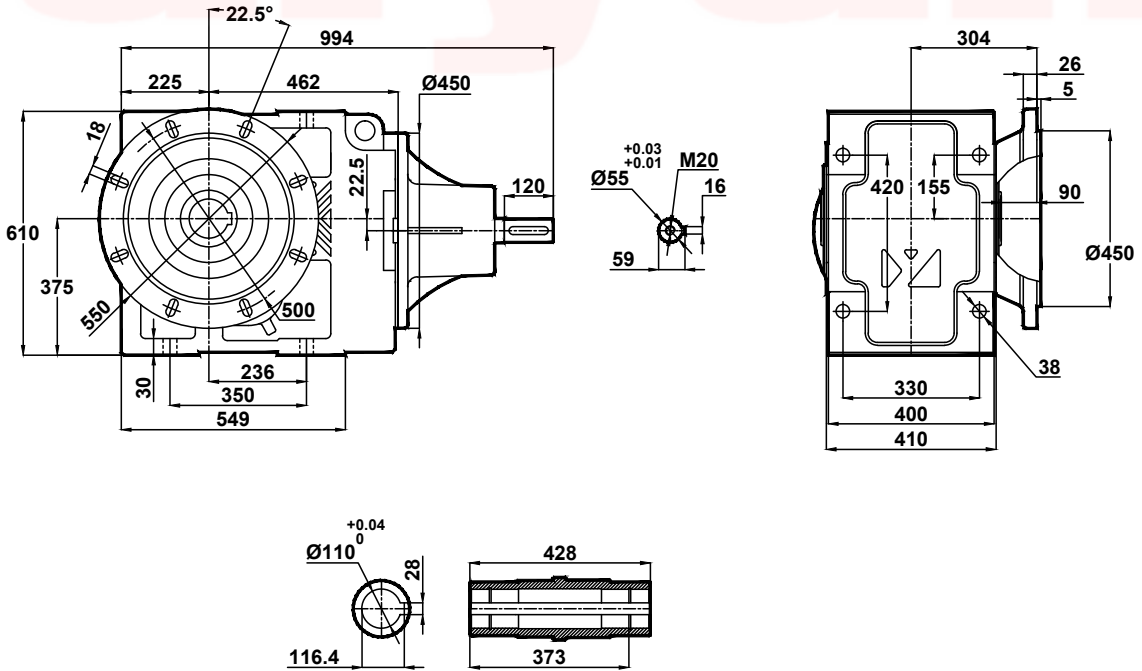



# Ölçü Sayfaları

## Dimension Pages

### Abmessungsseiten



-Mil ucu çekirme deliği DIN 332 sayfa 2 / Tapped center hole to DIN 332, sheet 2 / Zentrierung mit gewinde DIN 332, Blatt 2

KT873.04

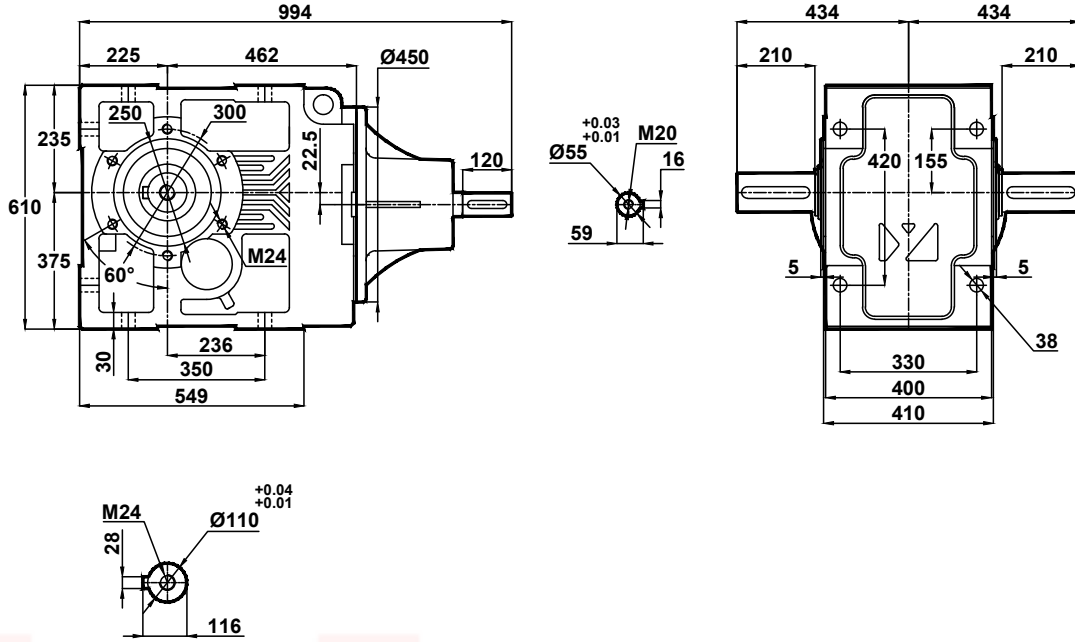

KT873.05

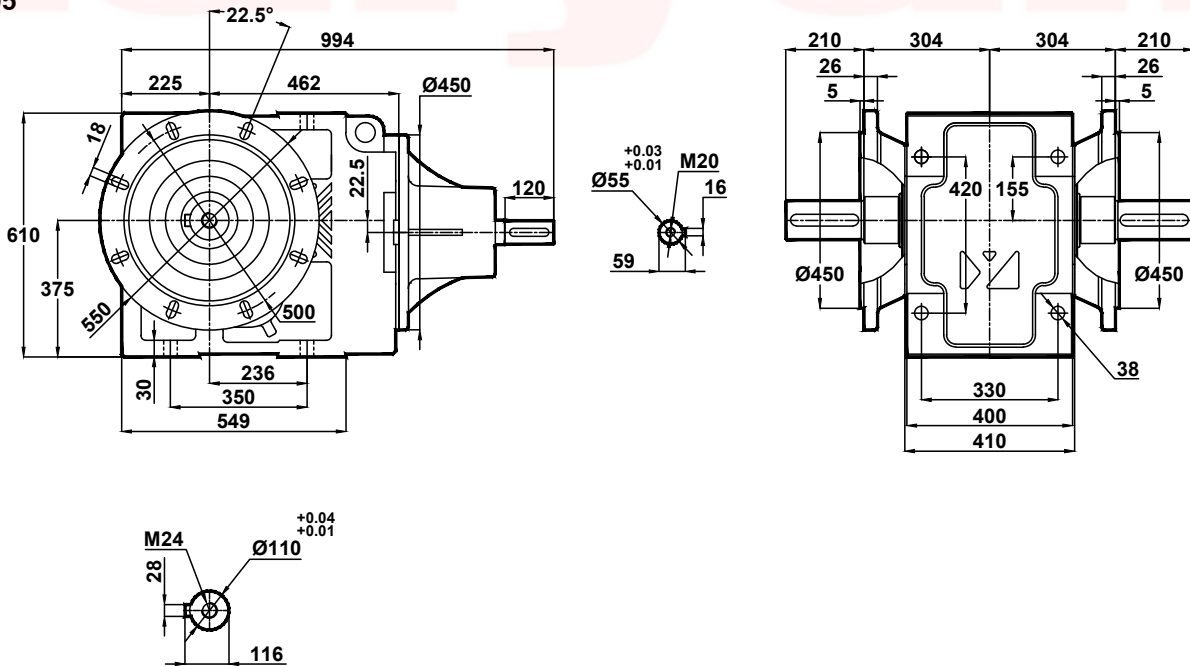





# Ölçü Sayfaları Dimension Pages Abmessungsseiten



-Mil ucu çekirme deliği DIN 332 sayfa 2 / Tapped center hole to DIN 332, sheet 2 / Zentrierung mit gewinde DIN 332, Blatt 2

KT873.08

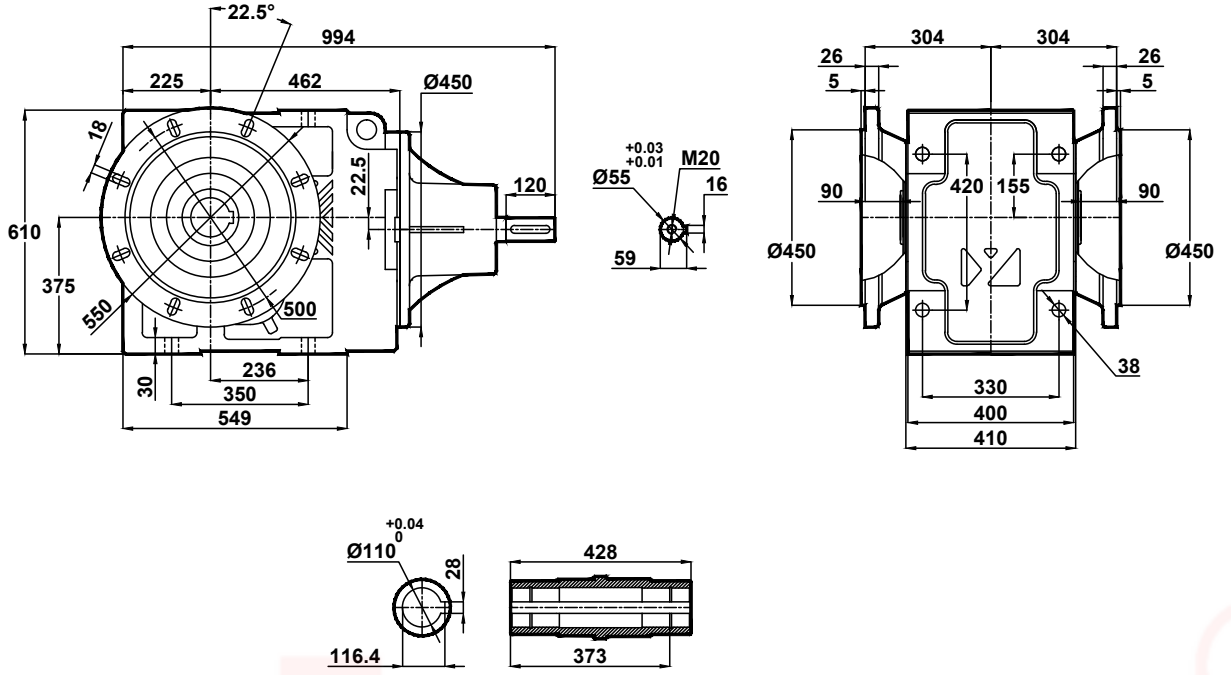



# Ölçü Sayfaları

## Dimension Pages

### Abmessungsseiten



-Mil ucu çekirme deliği DIN 332 sayfa 2 / Tapped center hole to DIN 332, sheet 2 / Zentrierung mit gewinde DIN 332, Blatt 2

KT874.00

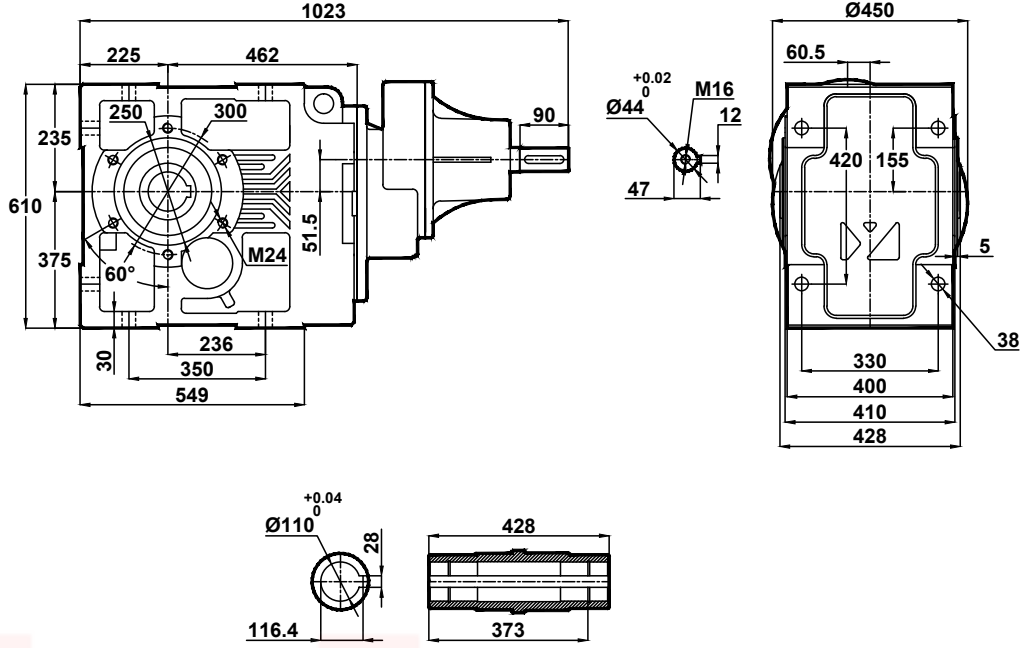

KT874.01

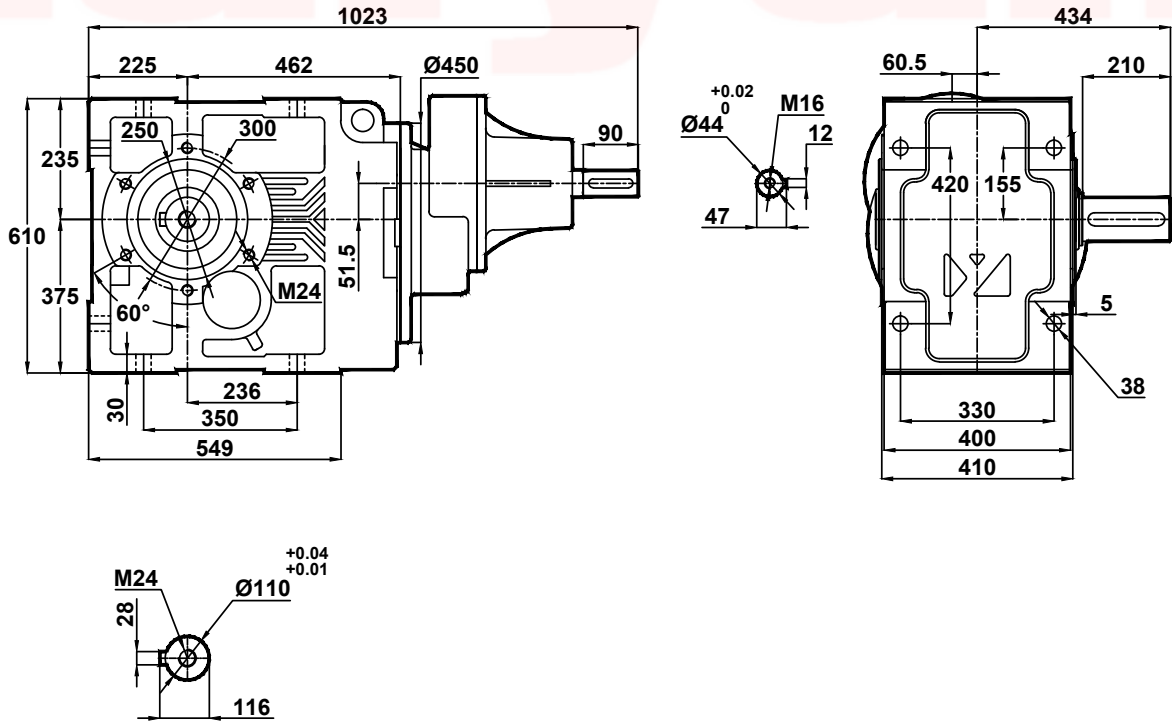



# Ölçü Sayfaları

## Dimension Pages

### Abmessungsseiten



-Mil ucu çekirme deliği DIN 332 sayfa 2 / Tapped center hole to DIN 332, sheet 2 / Zentrierung mit gewinde DIN 332, Blatt 2

KT874.02

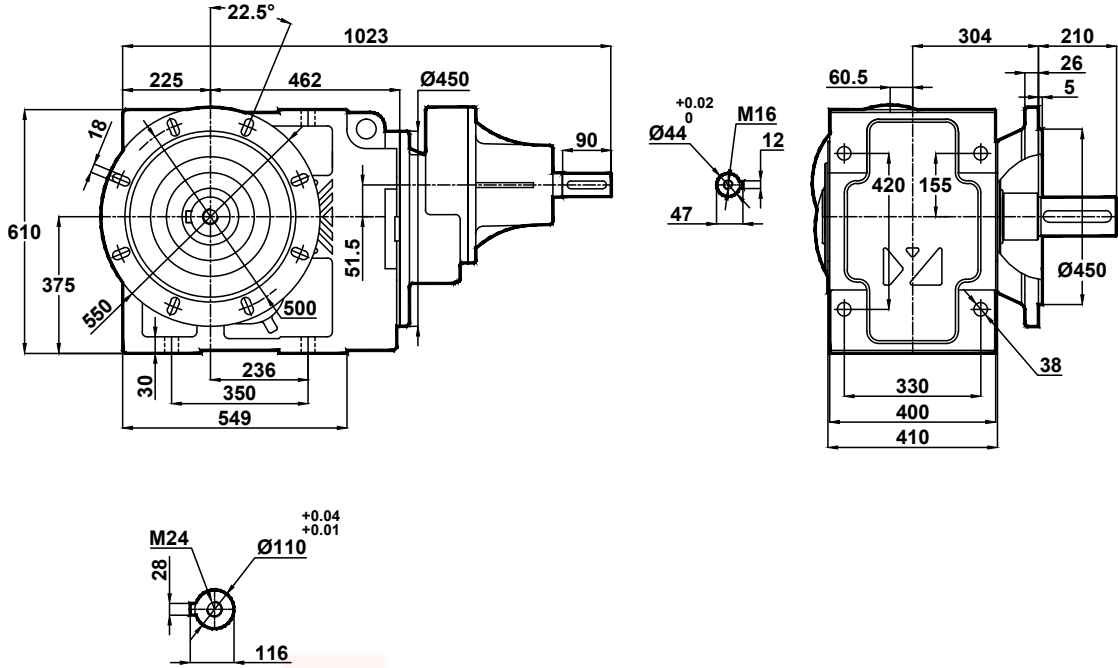

KT874.03

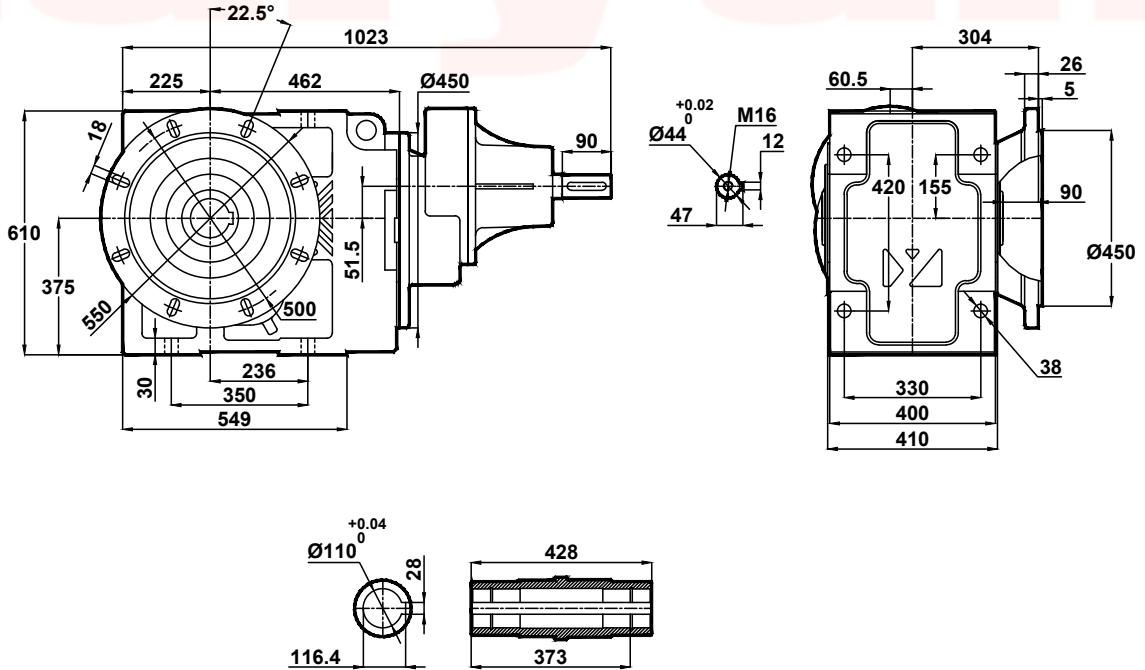



# Ölçü Sayfaları Dimension Pages Abmessungenseiten



-Mil ucu çekirme deliği DIN 332 sayfa 2 / Tapped center hole to DIN 332, sheet 2 / Zentrierung mit gewinde DIN 332, Blatt 2

## KT874.04

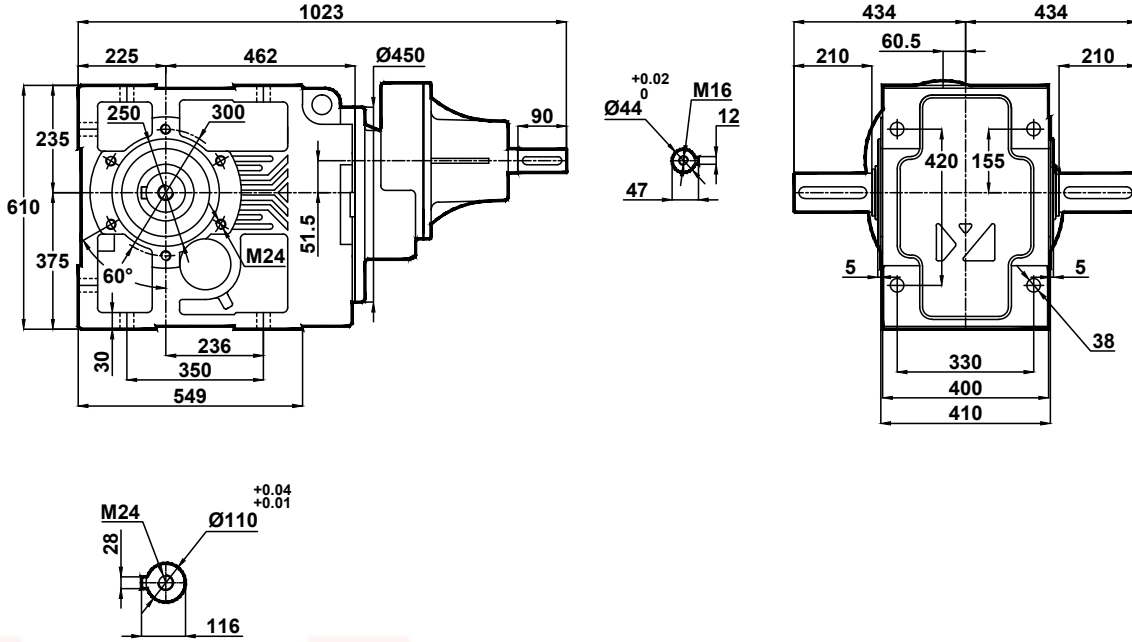

## KT874.05

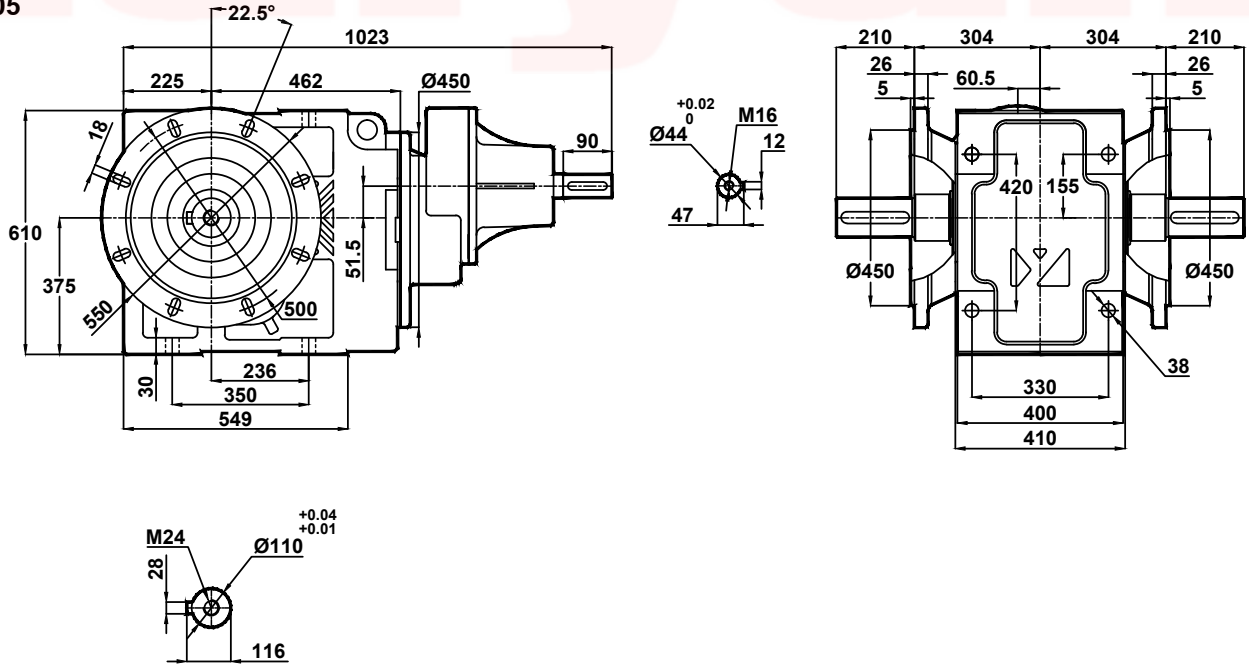



# Ölçü Sayfaları Dimension Pages Abmessungenseiten



-Mil ucu çekirme deliği DIN 332 sayfa 2 / Tapped center hole to DIN 332, sheet 2 / Zentrierung mit gewinde DIN 332, Blatt 2

KT874.08

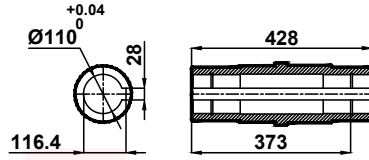
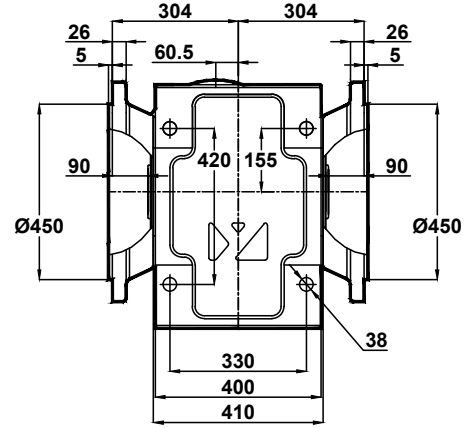
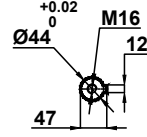
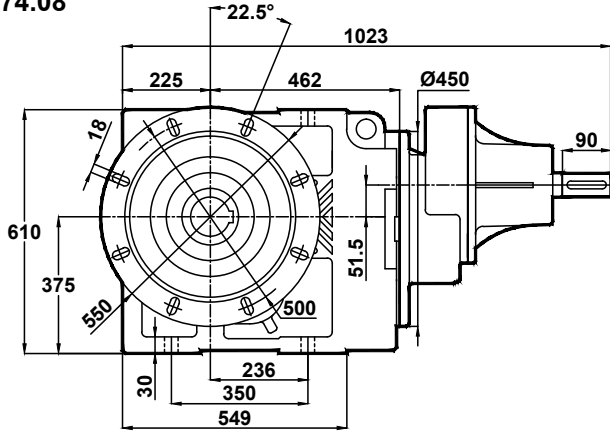



# Ölçü Sayfaları Dimension Pages Abmessungenseiten



-Mil ucu çektirme deliği DIN 332 sayfa 2 / Tapped center hole to DIN 332, sheet 2 / Zentrierung mit gewinde DIN 332, Blatt 2

KT875.00  
KT876.00

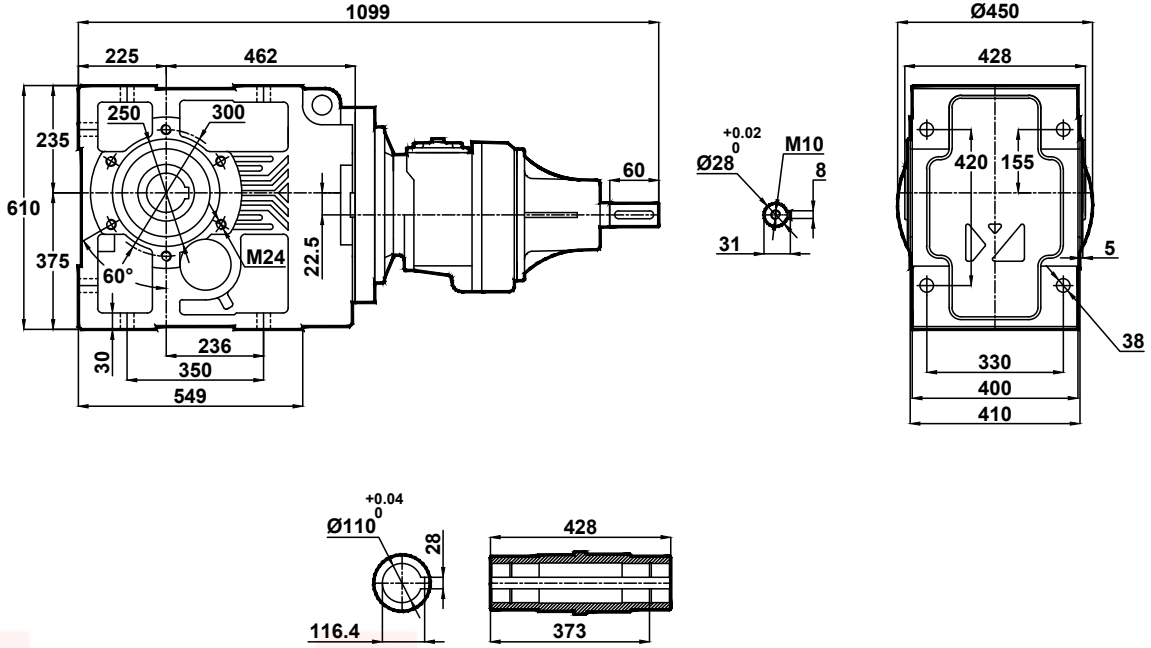

KT875.01  
KT876.01

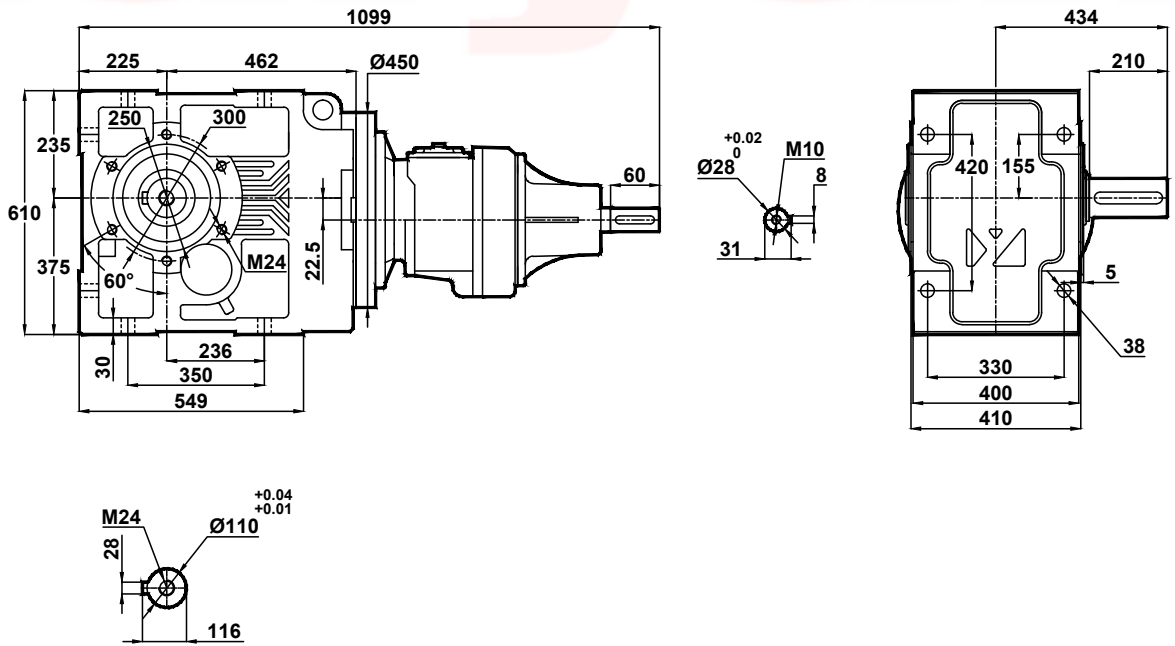



# Ölçü Sayfaları

## Dimension Pages

### Abmessungsseiten



-Mil ucu çekirme deliği DIN 332 sayfa 2 / Tapped center hole to DIN 332, sheet 2 / Zentrierung mit gewinde DIN 332, Blatt 2

KT875.02  
KT876.02

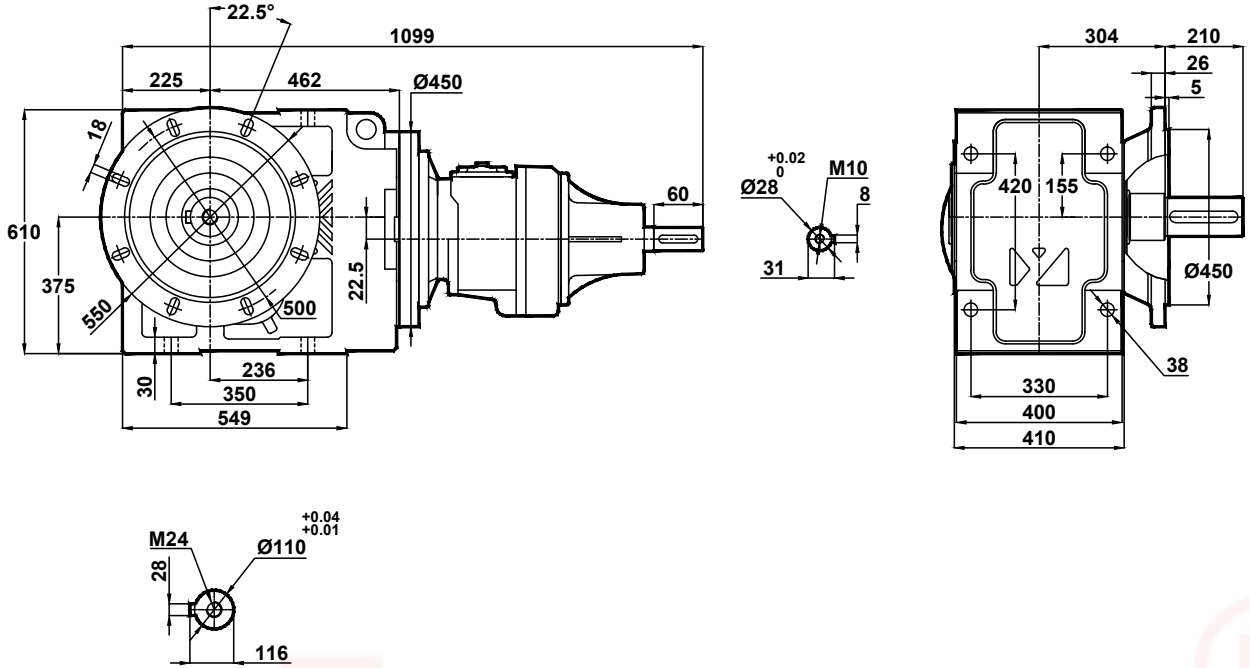

KT875.03  
KT876.03

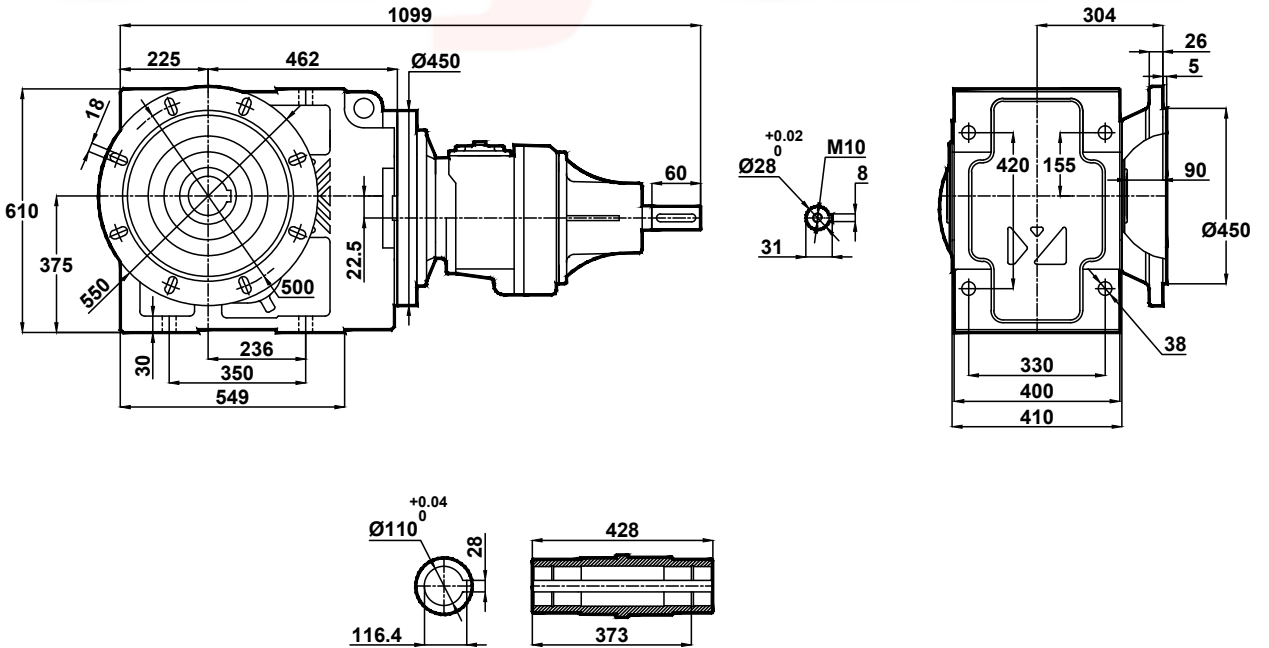



# Ölçü Sayfaları Dimension Pages Abmessungsseiten



-Mil ucu çekirme deliği DIN 332 sayfa 2 / Tapped center hole to DIN 332, sheet 2 / Zentrierung mit gewinde DIN 332, Blatt 2

KT875.04  
KT876.04

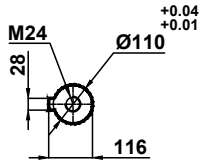
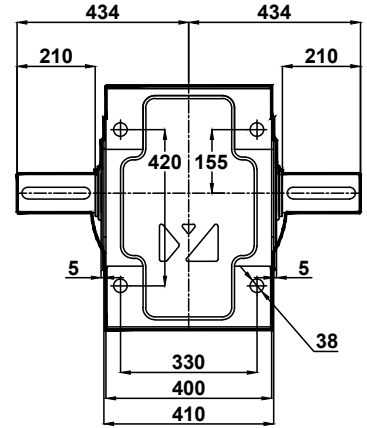
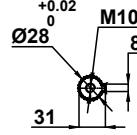
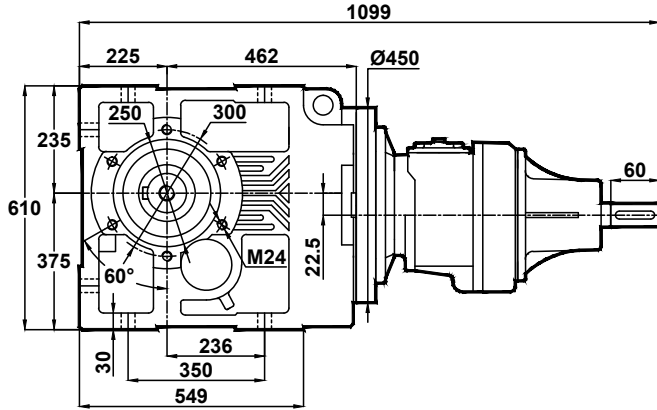

KT875.05  
KT876.05

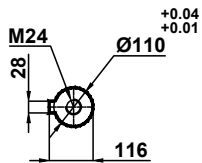
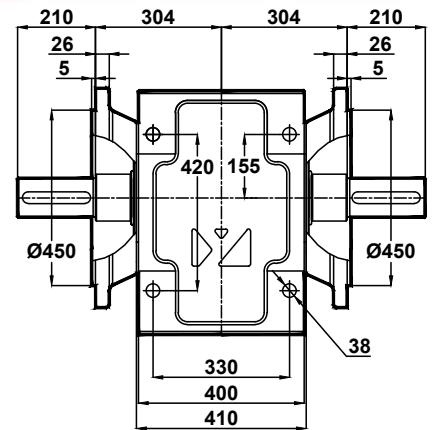
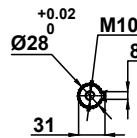
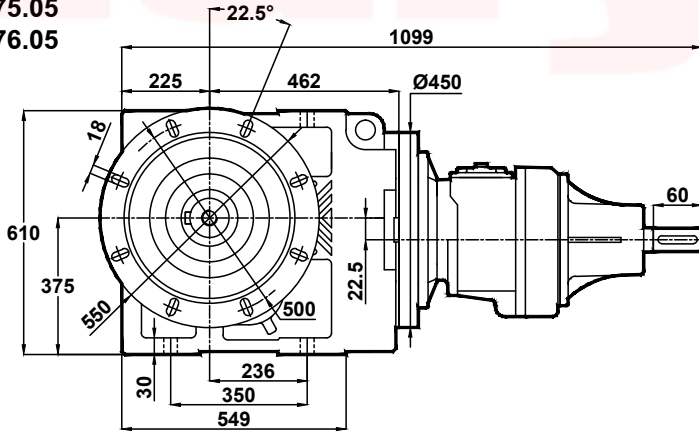





# Ölçü Sayfaları Dimension Pages Abmessungenseiten



-Mil ucu çekirme deliği DIN 332 sayfa 2 / Tapped center hole to DIN 332, sheet 2 / Zentrierung mit gewinde DIN 332, Blatt 2

KT875.08  
KT876.08

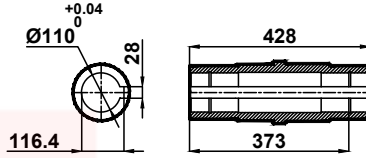
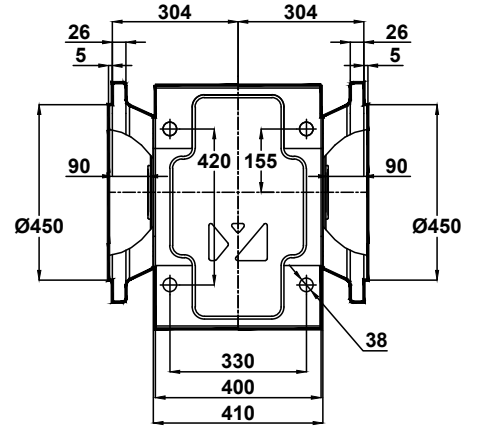
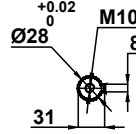
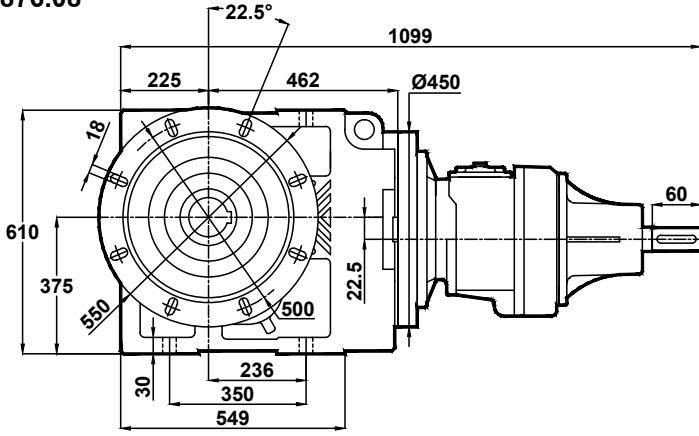



# Ölçü Sayfaları

## Dimension Pages

### Abmessungsseiten



## K Serisi Ekstruder Tip Redüktörler

### K Series Extruder Type Gearboxes

#### Extruder Getrieben von K Serie Getrieben

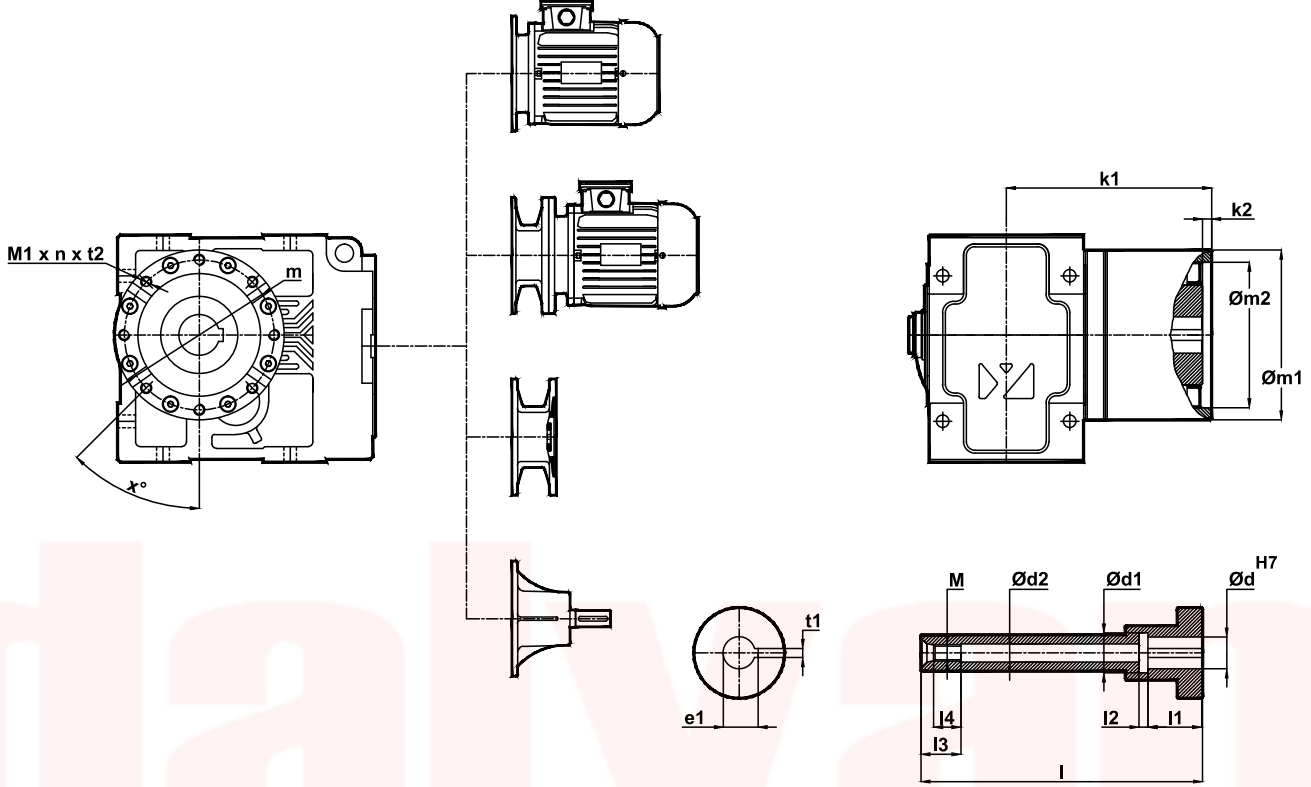

	Ød	Ød1	Ød2	l	l1	l2	l3	l4	M	k1	k2	m	m1	m2	M1	n	t2	x	t1	e1
<b>K..27..0E</b>	25	34	18	270	50	10	32	20	M16	186	10	130	150	100	M10	6	20	0	8	28.3
<b>K..37..0E</b>	35	44	20	310	60	10	44	30	M18	212.5	10	165	195	135	M12	8	25	0	10	38.3
<b>K..47..0E</b>	40	52	20	351	60	15	40	25	M18	242.5	10	185	215	160	M14	8	25	0	12	43.3
<b>K..57..0E</b>	50	61	26	401	70	15	48	30	M24	275	10	215	265	175	M14	8	25	0	14	53.8
<b>K..67..0E</b>	60	72	26	485	80	15	58	40	M24	312	10	265	305	200	M16	8	30	22.5	18	64.4
<b>K..77..0E</b>	70	88	33	572	120	15	67	50	M30	369	10	325	370	280	M20	8	35	22.5	20	74.9
<b>K..87..0E</b>	80	96	38	663	140	20	82	60	M36	423	10	350	430	310	M24	8	40	22.5	22	85.4



# Ölçü Sayfaları

## Dimension Pages

### Abmessungsseiten



#### K Serisi Delik Milli Sıkma Bilezikli Redüktörler

*K Series Hollow Shaft with Shrink Disk Connector*  
K Serie Hohwelle mit Schrumpfscheibe

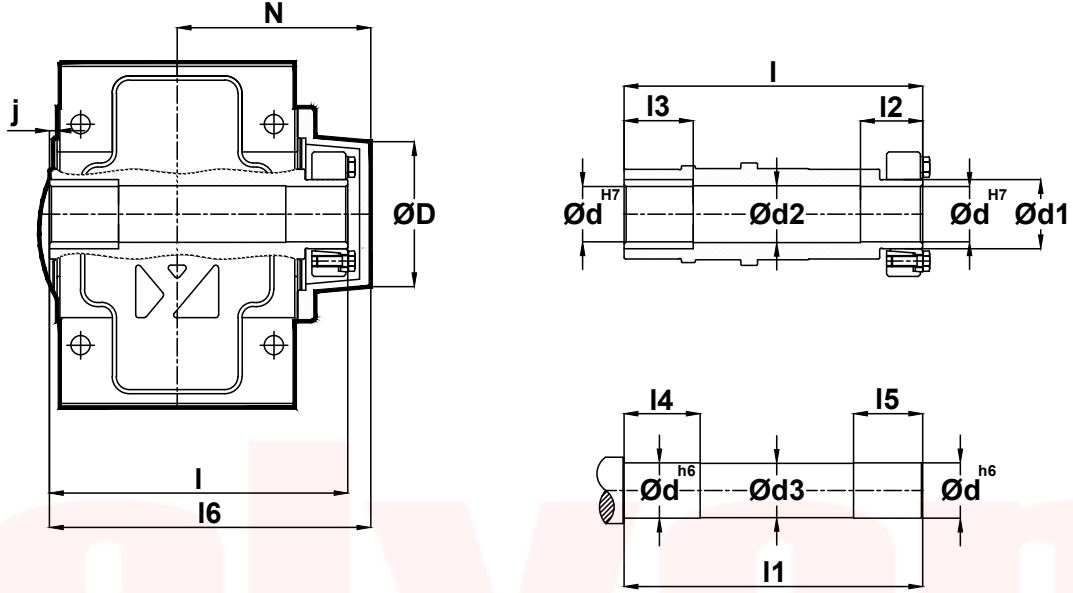

	ØD	Ød	Ød1	Ød2	Ød3	l	l1	l2	l3	l4	l5	l6	N	j	M	Z	Ta[Nm]
<b>K..27..0S</b>	98	35	44	36	34	186	189	35	25	30	43	201	122.5	4.5	M8	6	30
<b>K..37..0S</b>	106	40	50	41	39	216	219	40	35	40	48	233	140.5	5.5	M8	8	30
<b>K..47..0S</b>	129	50	62	51	49	249	252	45	40	45	53	236.5	156	5.5	M8	9	30
<b>K..57..0S</b>	164	60	75	61	59	282	285	50	45	50	58	302.5	179.5	5.5	M10	10	59
<b>K..67..0S</b>	164	70	80	71	69	345	348	55	50	55	63	364	210	6	M10	10	59
<b>K..77..0S</b>	219	90	110	91	79	418	421	70	60	70	83	438.5	257	7.5	M12	12	100
<b>K..87..0S</b>	260	110	130	111	109	492	495	80	70	80	93	517	303	9	M14	9	160



# Ölçü Sayfaları

## Dimension Pages

### Abmessungsseiten



### K Serisi Redüktör Kovan Ölçüleri

Hollow Shaft Dimensions for K Series Gearboxes  
Hohlwelleabmessungen Von K Serie Getrieben

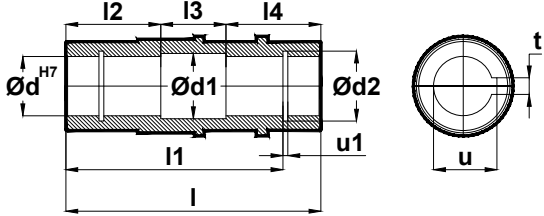

Tip Type Typ	d	d1	d2	l	l1	l2	l3	l4	u1	t	u
K.27..	35	36	37	157	132	60	37	60	1.6	10	38.3
K.37..	40	41	42.5	185	156	70	45	70	1.85	12	43.3
K.47..	50	51	53	215	183	82	51	82	2.15	14	53.8
K.57..	60	61	63	246	210	96	54	96	2.15	18	64.4
K.67..	70	71	73	308	270	110	88	110	2.65	20	74.9
K.77..	90	91	93.5	363	313	135	93	135	3.15	25	95.4
K.87..	110	111	114	428	373	160	108	160	4.15	28	116.4

### Moment Kolu Bağlantı Detayı

#### Torque Arm Assembling Details

#### Drehmomentstütze Montage Zeichnungen

Std

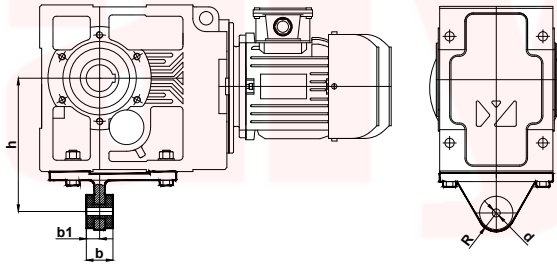

T1

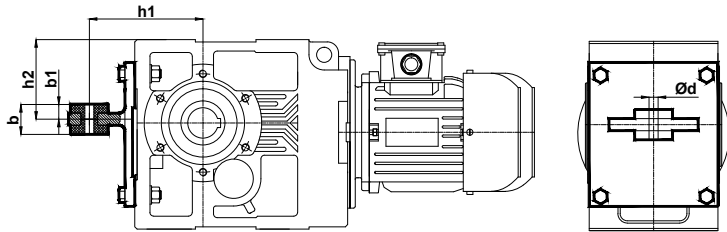

T2

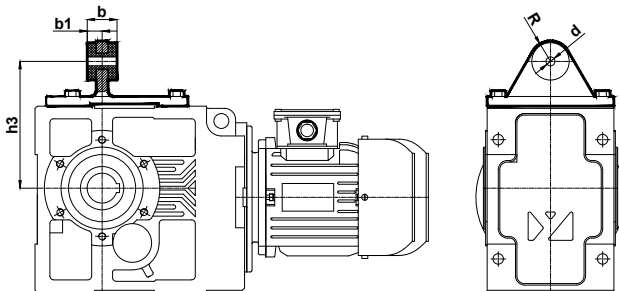

Tip /Type / Typ	Std / T1 / T2				Std.	T1	T2
	b	b1	d	R			
KR273.10	40	20	9	22,5	160	119	141
KR373.10	40	20	12	27,5	200	150	170
KR473.10	50	25	14	27,5	250	182	210
KR573.10	55	27,5	14	27,5	300	220	251
KR673.10	60	30	16	27,5	350	245	260
KR773.10	95	47,5	26	50	450	335	360
KR873.10	100	50	26	55	550	400	410

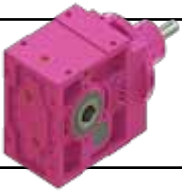

# Ölçü Sayfaları Dimension Pages Abmessungsseiten



**K Serisi Redüktörlerde Tavsiye Edilen Mil Boyu Montaj-Demontaj Şekli ve Aksesuarları**  
*Advised Mounting and Dismounting Figures of Shaft Lengths and Accessories for K Series Gearboxes.*  
Empfohlene Wellen Massen und Verbindungselemente Bei Montage für K Serie Getriebe

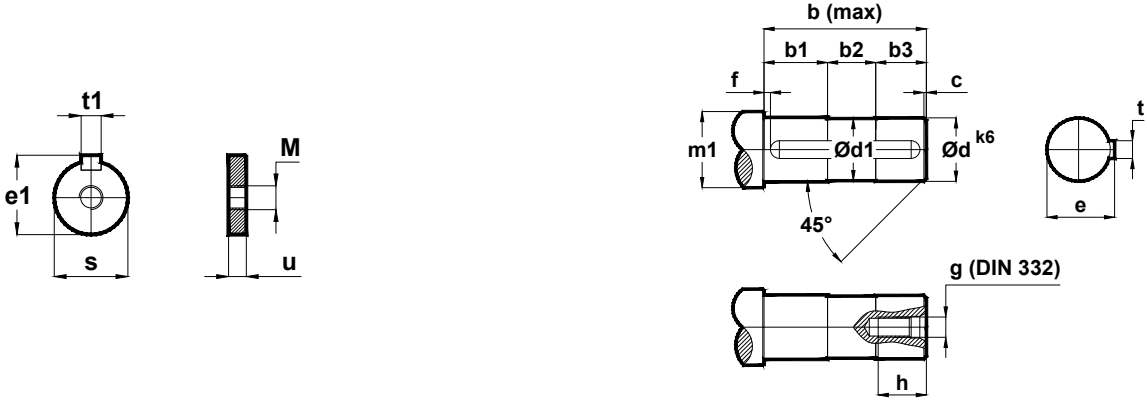

Tipi Type Typ	s	u	e1	t1	M	d	d1	m1	f	b	b1	b2	b3	c	g	h	e	t
K.27..	34.7	12	38	9.5	M16	35	34	43	5	114	65	27	22	1	M12	30	38	10
K.37..	39.7	12	43	11.5	M20	40	39	50		138	75	35	28	2	M16	38	43	12
K.47..	49.7	12	53.5	13.5	M20	50	49	60		165	87	41	37	3	M16	38	53.5	14
K.57..	59.7	16	64	17.5	M24	60	59	75		188	101	44	43	3	M20	44	64	18
K.67..	69.7	16	74.5	19.5	M24	70	69	85		248	115	78	55	4	M20	44	74.5	20
K.77..	89.7	20	95	24.5	M30	90	89	110		287	140	83	64	4	M24	52	95	25
K.87..	109.7	20	116	27.5	M30	110	109	130		347	165	98	84	4	M24	52	116	28

Mil Çektirme / Shaft Mounting / Einziehen

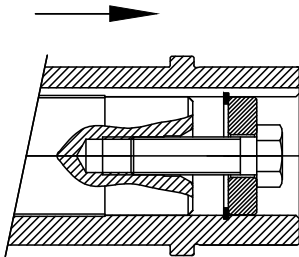

Mil Çıkartma / Shaft Dismounting / Heraus Drücken

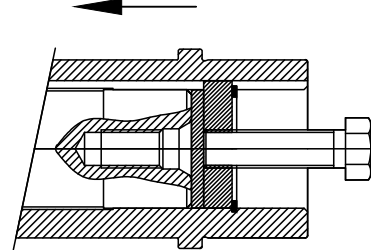

**6 Köşe Başlı Cıvata / 6 Contour Bolt / Sechskantschraube**  
(DIN ISO 4014 . DIN ISO 4017)  
(DIN ISO 8765)

